

# Square Terminal

## Getting Started



### Thanks for choosing to sell with Square Terminal

Start by pushing the power button located on the lower-left side of Terminal until the Square logo appears on the screen. Follow the steps on screen to connect to the internet, and then sign up for a new Square account or sign in to your existing account.

---

More information about getting started is also available at [square.com/go/terminal-guide](https://square.com/go/terminal-guide).

## Square Terminal

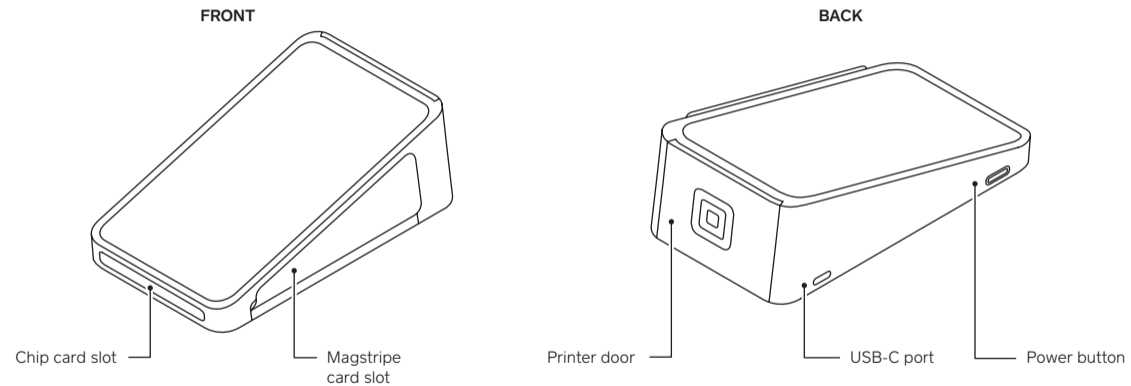

## What's in the box

---

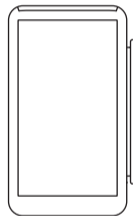

Square Terminal

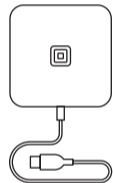

Power adapter

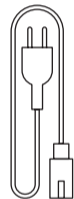

Power adapter cable

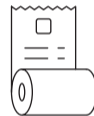

Receipt paper

## Charging your Terminal

---

Terminal has a rechargeable battery so it doesn't always need to be plugged into a power outlet. When the battery is running low, simply charge it up.

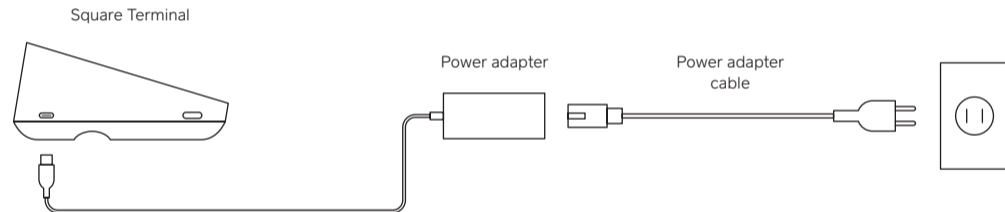

---

Plug in accessories and connect to the internet via Ethernet with Hub for Square Terminal. To learn more or buy Hub, visit [square.com/go/terminal-guide](https://square.com/go/terminal-guide).

## Loading receipt paper

---

Make sure you position and orient the roll exactly as shown in step 2. When tearing off a receipt, tear down toward the screen.

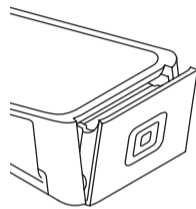

- 1** Open the printer door located just above the screen.

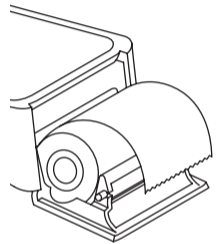

- 2** Unroll about an inch of paper from a new roll. Put the roll in the printer as shown above.

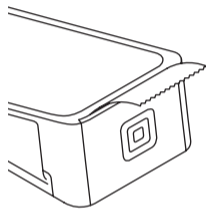

- 3** Align the paper with the feed slots, and then close the printer door. Tear off the excess paper.
- 

To view compatible receipt paper and to reorder, go to [square.com/go/terminal-paper](https://square.com/go/terminal-paper).

## Taking payments

---

Terminal lets you accept all major cards and contactless payments. To take a payment, ring up the sale and tap **Charge**.

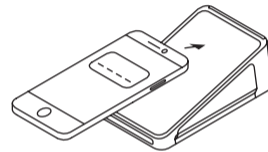

- Tap**  
Hold the device or card near the screen to trigger payment.

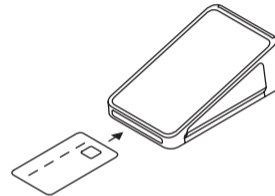

- Dip**  
Insert the chip card into the slot with the chip facing up.

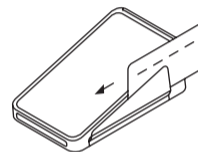

- Swipe**  
Swipe the card with the magnetic stripe facing Terminal.
- 

To learn more about taking payments, go to [square.com/go/terminal-guide](https://square.com/go/terminal-guide).

## HELP AND SUPPORT

Read our FAQ, learn more about compatible accessories, and get troubleshooting support at [square.com/go/terminal-guide](https://square.com/go/terminal-guide).

## HARDWARE WARRANTY

You're covered from defects for up to one year under a limited warranty. See [square.com/warranty](https://square.com/warranty).

## FREE 30-DAY RETURNS

Square offers a 30-day, risk-free return policy for all purchases made from [square.com/shop](https://square.com/shop). Simply go to [square.com/returns](https://square.com/returns) so we can make things right. After a return is complete, a refund will be credited back to you.

## REGULATORY INFORMATION

You can view regulatory information for Square Terminal by going to **Settings > General > About Terminal > Regulatory**. To view FCC information, go to **Support > Legal > Hardware Disclaimer**. This device complies with Part 15 of the FCC Rules. Operation is subject to the following two conditions: (1) this device may not cause harmful interference, and (2) this device must accept any interference received, including interference that may cause undesired operation.

Square Terminal - SPD1-01

Square, Inc., 1455 Market St., Ste. 600, San Francisco, CA 94103

[square.com/help](https://square.com/help)

