

## PWM dc 6v 12v 24v 28v 3a motor speed controller



This DC Motor Speed Controller allows controlling the direction of a DC motor using a Pulse– Width– Modulated (PWM) DC voltage with a Duty Cycle fully adjustable from 0%-100%. The motor speed controller can easily provide a continuous current of 3A to your DC motor or other DC load.

## PWM dc 6v 12v 24v 28v 3a motor speed controller

### Main technical parameters:

- Input supply voltage:6V-28VDC
- The maximum output power: 80W
- The maximum continuous output current :3A
- Duty Cycle adjustable:5%-100%

### Operating instruction:

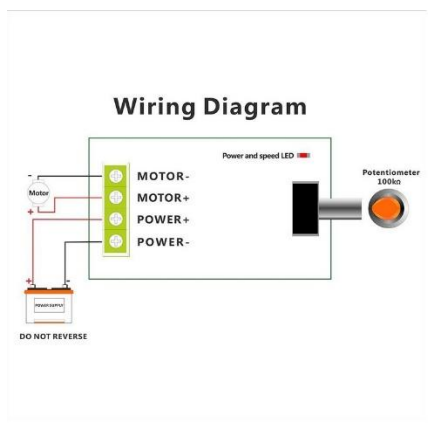

Before you attempting to wire the controller, make sure power is off.

**WARNING: DO NOT REVERSE POSTIVE AND NEGATIVE POWER LOADS.THIS WILL DAMAGE THE CONTROLLER.**

**TO CHANGE MOTOR DIRECTION, INTERCHANGE THE POSITIVE AND NEGATIVE WIRES OF MOTOR.**

1. PWM dc 6v 12v 24v 28v 3a motor speed controller Connect your DC motor (or DC load) to the motor terminals as indicated on the wiring diagram.
2. Connect PWM dc 6v 12v 24v 28v 3a motor speed controller a voltage of 10V-36V DC to the circuit making sure of the correct polarity of the connection. Note that the voltage applied to the motor will be supply voltage applied to the circuit. It is recommended to add an appropriately rated fuse inline with the positive supply in order to protect the circuit from any possible short circuits.
3. You can now control the speed of the motor through potential meter