

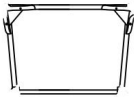





# ASSEMBLY INSTRUCTION FOR ACME FURNITURE

## 58267 CHAIR

Thank you for purchasing this quality product. Be sure to check all packing material carefully for small parts which may come loose inside the carton during shipment. Identify and count all parts and metal hardware. Compare with the part list to be sure all parts are present, If any part(s) are missing or damage, please contact your local furniture dealer. For efficient and speedy service, please indicate the model number and code letter of part(s) needed.

\*\*Assemble the product on a flat, soft surface such a carpet or cloth to prevent scratching the product finish. Read all instruction and study the drawing carefully before starting the assembly process.

PART LIST			
NO	PART	DECS	QTY
A		CHAIR	1
B		Rear Leg	2
C		Front leg	2
D		PILLOW	1

HARDWARE LIST			
NO	HARDWARE	DECS	QTY
1		BOLT 8*70mm	6PCS
2		FLAT WASHER φ20mm	6PCS
3		ALLEN WRENCH 40*70mm	1PC

**Attention** \*\*\*Some number parts listed on the instruction sheet may not be in parts bag as they may be assembled. Carefully check parts and packing materials prior to ordering replacements

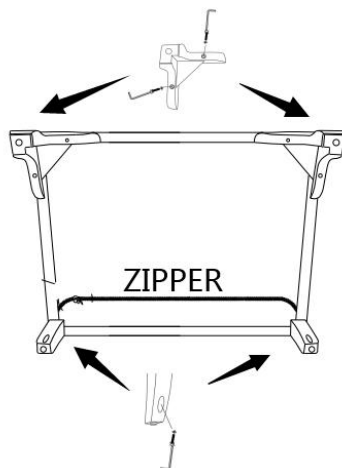

### STEP

1. Turn the CHAIR down on a smooth, soft surface and unzip the black bottom fabric, take out the LEGS AND HARDWARE
2. Attach the leg to the bottom of base as the diagram.
3. Tighten the leg AND Zipped up the black bottom fabric.

\*\*Assembly step 4pcs legs for the CHAIR are same as the drawing.





MADE IN CHINA

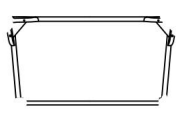

# ASSEMBLY INSTRUCTION FOR ACME FURNITURE

## 58266 LOVESEAT

Thank you for purchasing this quality product. Be sure to check all packing material carefully for small parts which may come loose inside the carton during shipment. Identify and count all parts and metal hardware. Compare with the part list to be sure all parts are present, If any part(s) are missing or damage, please contact your local furniture dealer. For efficient and speedy service, please indicate the model number and code letter of part(s) needed.

**\*\*Assemble the product on a flat, soft surface such a carpet or cloth to prevent scratching the product finish. Read all instruction and study the drawing carefully before starting the assembly process.**

PART LIST			
NO	PART	DECS	QTY
A		LOVESEAT	1
B		Rear Leg	2
C		Front leg	2
D		PILLOW	3

HARDWARE LIST			
NO	HARDWARE	DECS	QTY
1		BOLT 8*70mm	6PCS
2		FLAT WASHER φ20mm	6PCS
3		ALLEN WRENCH 40*70mm	1PC

**Attention** \*\*\*Some number parts listed on the instruction sheet may not be in parts bag as they may be assembled. Carefully check parts and packing materials prior to ordering replacements

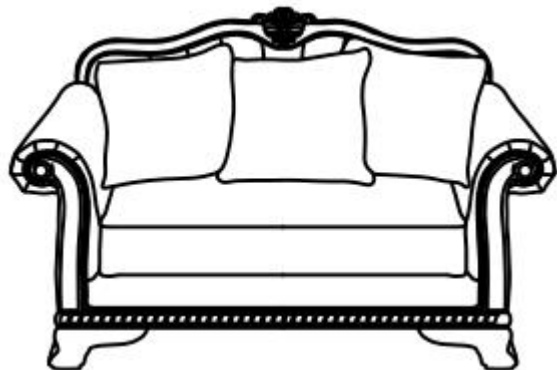
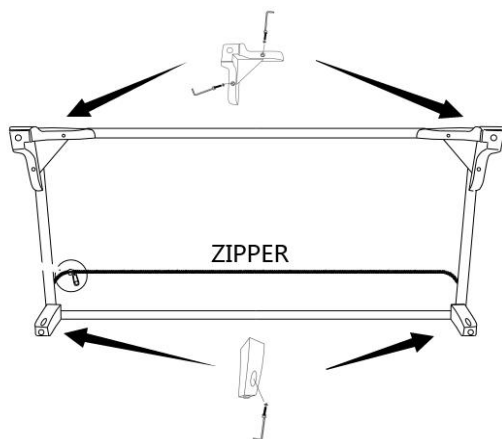

### STEP

1. Turn the LOVESEAT down on a smooth, soft surface and unzip the black bottom fabric, take out the LEGS AND HARDWARE
2. Attach the leg to the bottom of base as the diagram.
3. Tighten the leg AND Zipped up the black bottom fabric.

**\*\*Assembly step 4pcs legs for the LOVESEAT are same as the drawing.**





MADE IN CHINA

# ASSEMBLY INSTRUCTION FOR ACME FURNITURE

## 58265 SOFA

Thank you for purchasing this quality product. Be sure to check all packing material carefully for small parts which may come loose inside the carton during shipment. Identify and count all parts and metal hardware. Compare with the part list to be sure all parts are present, If any part(s) are missing or damage, please contact your local furniture dealer. For efficient and speedy service, please indicate the model number and code letter of part(s) needed.

\*\*Assemble the product on a flat, soft surface such a carpet or cloth to prevent scratching the product finish. Read all instruction and study the drawing carefully before starting the assembly process.

PART LIST			
NO	PART	DECS	QTY
A		sofa	1
B		CENTER LEG	1
C		Rear Leg	2
D		Front leg	2
E		PILLOW	5

HARDWARE LIST			
NO	HARDWARE	DECS	QTY
1		BOLT 8*70mm	6PCS
2		FLAT WASHER φ20mm	6PCS
3		ALLEN WRENCH 40*70mm	1PC

**Attention** \*\*\*Some number parts listed on the instruction sheet may not be in parts bag as they may be assembled. Carefully check parts and packing materials prior to ordering

replacements

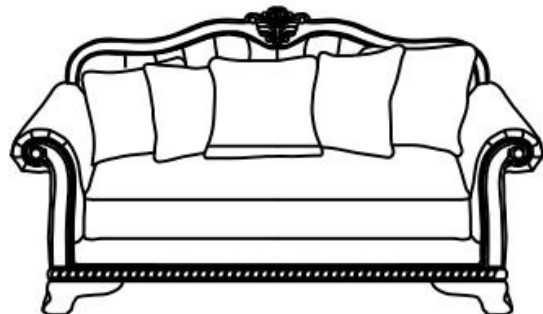
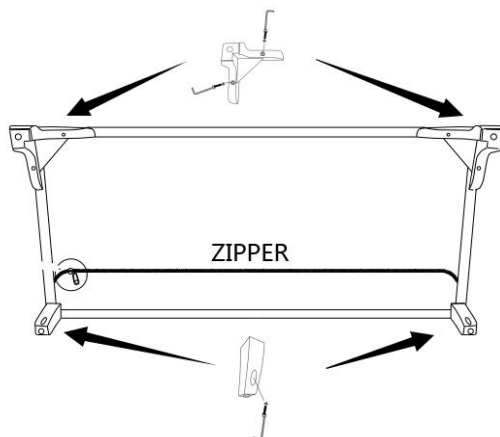

### STEP

1. Turn the SOFA down on a smooth, soft surface and unzip the black bottom fabric, take out the LEGS AND HARDWARE
2. Attach the leg to the bottom of base as the diagram.
3. Tighten the leg AND Zipped up the black bottom fabric.

\*\*Assembly step 4pcs legs for the SOFA are same as the drawing.

MADE IN CHINA