



CURT™

The FIRST Name
in Towing Products™

E16 5TH WHEEL

INSTRUCTION MANUAL



Installer: read and understand this manual. Fully instruct and demonstrate the operation of this 5th wheel hitch to the end user. Include the importance of observing all warnings contained herein, including warning labels on 5th wheel hitch mid section. Provide this manual in its entirety to the end-user.

WARNING: to avoid serious injury, do not expose hands, body parts, or clothing between the truck and trailer or the truck's bed sides and trailer. Extreme care should be observed to avoid serious injury to self, property, and observers.

Never Position yourself or others under the trailer's kingpin area during coupling and uncoupling. Serious injury or death may result if the warning above is not observed.

E5 5th Wheel Hitch Unpacking

1. Unpacking

The E5 5th Wheel Assembly ships in three boxes as indicated below. Inspect all parts for damage and verify that all items listed are present.

Box 1 Contains:

- CM-16115-HHA E5 Hitch Head Assembly (Qty 1)
- CM-16115-H Handle (Qty 1)
- CM-16115-HG Handle Grip (Qty 1)
- CM-16115-MCW Mounting Channel Weldment (Qty 2)
- CM-16115-CMW Cross Member Weldment (Qty 1)
- CM-16115-BK Bolt Kit (includes all hitch hardware shown) (Qty 1)

Box 2 Contains:

- CM-16100-MRK Mounting Rail Kit (Ordered Separately) (Qty 1)

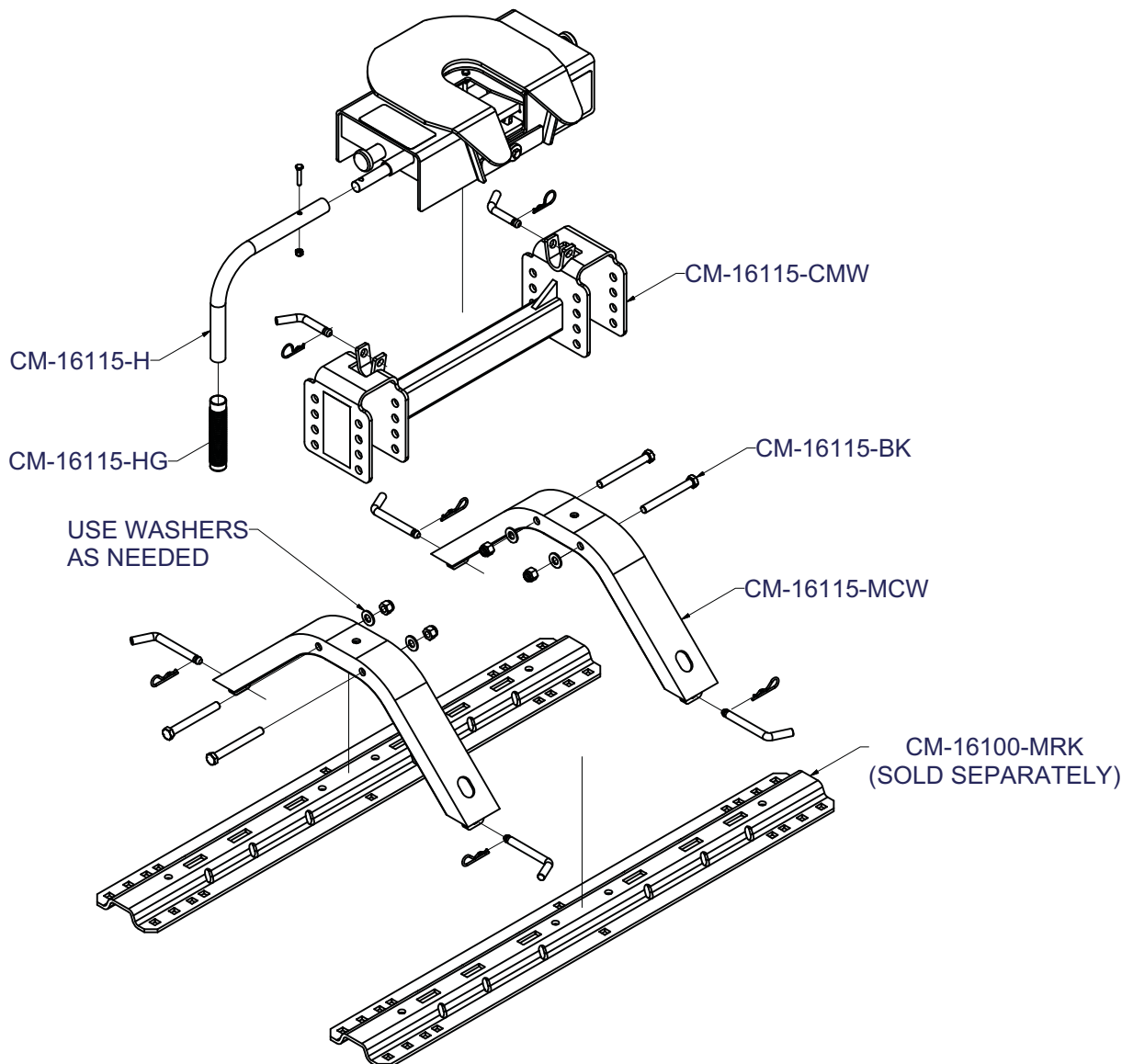

E5 5th Wheel Hitch Assembly

1. Hitch Handle Assembly

- a) Rotate the handle shaft so the bolt hole is oriented at the top.
- b) Hold the handle with the grip pointed downward and slide the handle onto the handle shaft.
- c) Fasten the hitch handle using the supplied bolt and nylock nut.

2. Hitch Assembly

- a) Attach the hitch handle to the hitch head. [See hitch handle assembly]
- b) Place the mounting rails [CM-16100-MRK] in the bed of the truck using the supplied installation instructions.
- c) Place the mounting channels into the mounting rails and secure using the ½" diameter clevis pins [CM-16115-RMP]. Secure the clevis pins using the large hairpin clips [CM-16115-RHP] in the bolt kit.
- d) Slide the cross member weldment over the mounting channels. From the outside, insert four ½" x 4 ½" bolts into the four holes of the cross member weldment. Place nylock nuts on each bolt and finger tighten. (Use washers as needed to eliminate any gaps between the mounting channels and the cross member weldment)
- e) Place the hitch head onto the cross member weldment and secure with the supplied 3/8" clevis pins [CM-16115-HHMP] and hairpin clips [CM-16115-HHHP]. Check for freedom of movement.
- f) The E5 5th Wheel Hitch System is now ready for installation.

E5 5th Wheel Hitch Operation and Maintenance

About your E5

The Curt Manufacturing E5 Fifth Wheel Hitch System is designed to tow 5th Wheel Trailers with a Gross Vehicle Weight Rating up to 16,000 lbs. ***Exceeding the rated capacity could create an unsafe towing condition and is not recommended.*** It has a 4-way swivel head, is height adjustable from 13 to 17 inches in 1 ¼" increments, and is removed from the bed of the truck by pulling 4 retaining pins.

Preparing For First Use

Your E5 is now installed and you're ready to tow. You're almost there, but take a few minutes to ensure your hitch is setup properly for your particular truck/coach combination by following the steps below.

1. Verify the cross member is set at the proper height to provide a minimum of 5-1/2" clearance between the bottom of the trailer nose and the top of the truck box and allows for a level towing attitude of the coach. If necessary, adjust the cross member to the proper height, ensuring the fasteners are re-torqued to 75 ft-lbs.
2. Ensure the coach wheels are blocked front & rear and the rear stabilizer jacks are fully retracted.
3. Level the coach so the bottom plate of the kingpin box is level with the skid plate on the top of the hitch head.
4. Rotate the handle of the hitch 180 degrees so the handgrip is pointing straight up and pull the handle out until the slide bar is held open by the locking angle.
5. Slowly back the truck so the bottom plate of the kingpin box slides onto the skid plate and the kingpin slides fully into the throat of the hitch head. Set the parking brake of the truck and place the transmission into park.
6. Visually verify the slide bar has closed behind the kingpin and the kingpin box is resting on the skid plate. Positively lock the slide bar by rotating the handle so the handgrip is pointing straight down at the bed of the truck.
7. Attach the electrical and breakaway connectors to the proper receptacles in accordance with your coach owners manual, remove the blocks from the wheels of the coach and double check that the hitch is properly attached to the coach.

Once you arrive at your destination, follow these simple steps to properly uncouple your coach from your E5.

1. Block your coach wheels front & rear.
2. If necessary, start your truck and back up against the kingpin to relieve pressure on the slide bar. Set the parking brake, put the transmission in park and turn off your vehicle.

3. Extend the front landing gear of the coach until the weight of the coach is just off of the skid plate of the hitch. Do not exceed 1/16" gap between the bottom plate of the kingpin box and the skid plate of the hitch. **Caution: Raising the coach too high while still connected can damage the hitch head as well as components of your coach. Do not extend the rear stabilizers of the coach prior to or during uncoupling.**
4. Disconnect the electrical and breakaway connectors in accordance with your coach owner's manual. Rotate the handle of the hitch 180 degrees so the handgrip is pointing straight up, then pull the slide bar all the way open. Lock the hitch handle in the open position by rotating it clockwise 180 degrees until the handgrip is pointing down at the bed of the truck.
5. You are now ready to pull your truck slowly away from the coach.

Maintaining Your E5

1. After coupling, always visually check that the slide bar has closed completely across the rear of the kingpin.
2. After the first 100 miles, and at least once a year thereafter, inspect all bolts for proper tightness. Re-tighten bolts if needed. All fasteners should be torqued to 75 ft-lbs.
3. Once or twice a year, apply a light coat of wheel bearing grease to the surface of the slide bar that holds the kingpin in place. For best results, apply the grease with the slide bar in the closed position. Then pull the slide bar open and apply a light coating of grease to the slide bar shaft that the handle is attached to. **Caution: The slide bar can close with heavy force. Use extreme care to keep fingers, hands, extremities, and clothing out of the path of the slide bar. Failure to do so could result in severe injury.**
4. At least once a year, thoroughly clean and degrease the hitch head assembly. After cleaning, lubricate as mentioned above.
5. Periodically inspect your E5 for wear or damage. If excessive wear or damage is found, contact Curt Manufacturing Technical Support Department for assistance at (877) 287-8634.

E5 5th Wheel Hitch Hook Up Instructions

Warning: Do not operate this Hitch without reading the Operating Instructions first.

1. Hook-up truck and trailer only on a firm, dry, level surface.
2. Place wheel chocks on both sides of the trailer, in front and behind the trailer tires, to prevent any movement. Stones, bricks, and wood blocks are not adequate to secure a trailer.
3. Adjust 5th wheel hitch head in the truck to a level position.
4. Lower the truck tailgate.
5. Back up the truck slowly and stop just before the trailer's king pin box.
6. Put the trucks transmission "In Park". Activate the emergency brake on the truck. Turn off the engine.
7. Adjust the front trailer jacks so the height on king pin plate $\frac{1}{2}$ inch to 1 inch below the skid plate of the 5th wheel hitch. **NEVER LOWER THE KING PIN INTO THE HITCH HEAD.**
8. The 5th Wheel Hitch handle is located on the drivers' side of the 5th wheel hitch, in the bed of the truck. Rotate the hitch handle to the "up" position. Pull the hitch handle until it is extended and remains in the "open" position.

Warning: To avoid serious injury – do not expose any body parts, clothing, pets, or valuables between the truck and trailer, the truck-bed sides and trailer, or in the bed of the truck.

9. Back the truck up slowly until the king pin plate compresses the suspension of the truck – the king pin travels until it stops within the hitch head assembly, and activates the handle release mechanism. The handle will then slide toward the 5th wheel hitch, and then rotate to the "down" position.
10. Put the truck's transmission "In Park". Activate the emergency brake on the truck. Turn off the engine.
11. (a) Exit the truck. Check to see if the hitch handle is pointed all the way "down" – If not, rotate the handle to the "up" position and pull until it extends to the locked "open" position. Repeat steps 5–11.

(b) Visually check to see if the trailer king pin plate and the 5th wheel skid plate are "sandwiched" together. There should not be any gaps between the trailer king pin plate and the 5th wheel hitch skid plate. If a gap is present, it's possible the hitch connection is not complete. Repeat steps 5–11.

(c) If the handle is positioned all the way "down", and there is no gap between the trailer king pin plate and the 5th wheel hitch skid plate, proceed with step 12.

12. Lift up and latch the truck tailgate into the “up” position.
13. Apply the truck’s brakes, start the engine, put the truck in gear to give a slight “tug” for an inch or two and check the hitch connection. Be careful not to let the trailer slip off the 5th wheel hitch. If the connection is complete, the trailer king pin plate and 5th wheel hitch skid plate should not slide apart and act as one piece. A complete connection will “rock” the trailer and resistance can be felt.
14. Put the truck’s transmission “In Park” and activate the trucks emergency brake. Turn off the engine.
15. Raise the front trailer jacks to allow maximum ground clearance.
16. Attach the trailer connector to the truck.
17. Attach the lanyard and insert the plunger into the electric brake-away switch. (If hydraulic surge brakes are present, attach lanyard from the surge brake assembly to the hitch.)
18. Remove the trailer wheel chocks.
19. Check running lights, directional signals, and brake lights for proper operation.
20. Pull forward a few feet and apply the brakes to verify the trailer brakes are working properly. Adjust the electric brake controller if necessary for proper activation.
21. Proceed with caution!!

If you have any concerns or questions regarding these hook-up instructions, please contact the dealer or installer where you purchased your 5th Wheel Hitch to answer your questions.

Safety Warnings & Precautions

1. Safety Warnings

- Trailer along with contents ***must not*** exceed truck, hitch, or trailer tow ratings.
- Vehicle towing the trailer ***must have*** a manufacturer's rated towing capacity equal to or greater than the gross trailer weight.
- Gross weight of the trailer ***must not*** exceed hitch capacity (16,000 pounds). Exceeding the rated capacity is not recommended.
- King pin weight ***must not*** exceed 3750 pounds.
- When installing the frame brackets, make sure three wheels are firmly on the ground at all times and blocked with the axle firmly supported to prevent ***INJURY or DEATH*** from falling truck.

2. Precautions

- ✓ Prior to drilling into the truck bed or frame for installation of the hitch mounts, be sure to locate the brake, fuel, and electrical lines. Temporarily relocate them if necessary to avoid possible damage.
- ✓ Due to variations in chassis suspension component locations it may be necessary to change long & short bracket locations. Always check proper fit prior to installation.
- ✓ On all installations there ***must*** be a minimum of 5½ inch clearance between the bottom of the trailer nose and the top of the truck bedsides. This is to prevent damage to the truck, trailer, or hitch due to lack of clearance.