

FLOJET

“Quad II Diaphragm” 4405 Series Automatic Water System Pump With Internal Bypass Valve

FEATURES

- Self-Priming
- Dry Running
- Soft, Noise Absorbing Mounts
- Corrosion Resistant Materials
- Models Meet U.S.C.G. Electric Standards
- Smooth Operation Without Accumulator Tank

SPECIFICATIONS

Motor: Permanent Magnet, Ball Bearing. CE Models are fully suppressed.

Pump:

without damage; Removable port to hose connectors.
Four chamber diaphragm design; Self-priming up to 6 ft. suction lift; Pump able to run dry

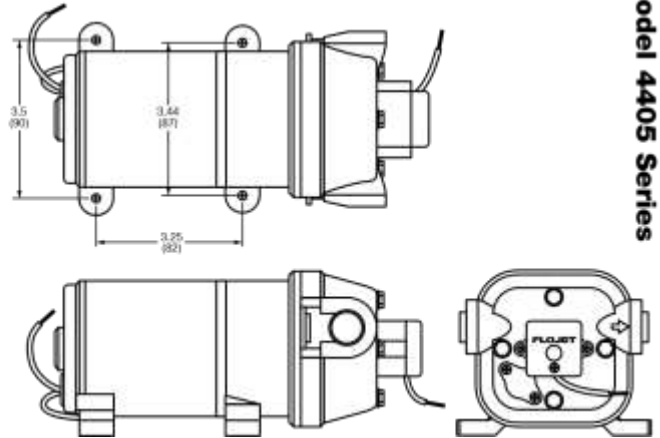

Note: The built-in bypass valve eliminates the need for an accumulator tank. Do not install in a system with an accumulator tank. The tank will interfere with the internal bypass valve.



(Available on 12 & 24V d.c. Models)
3.9 (1.8)

Pump Series	Dimensions - Inches (mm)			Weight lb. (kg)
	Height	Width	Length	
4405-XXX	3.75 (95)	6.3 (160)	8.2 (208)	

MODEL*	VOLTS	AMP DRAW	FLOW	PRESSURE SWITCH
		@ 10 psi (0.7 bar)	GPM (l/min)	MAX psi (bar)
4405-143	12V dc	3.9	3.3 (12.5)	35 (2.4)
4405-343	24V dc	2.0	3.3 (12.5)	35 (2.4)
4405-443	32V dc	1.3	3.3 (12.5)	35 (2.4)

* CE fully suppressed models are identified by a prefix “R” and a CE mark on the label. (i.e. R4405-343). Self Declaration Of Conformance (SDOC) is available upon request.

OPERATION

With pump switch off, and battery fully charged, fill water toilet and shower lines. When all valves are shut off tank, open all faucets then turn pump switch on. Water pump will stop. Should pump fail to stop, turn switch off will begin to flow, when water is free of air, turn faucets and see the trouble shooting guide. off, remember you are filling the water heater and the

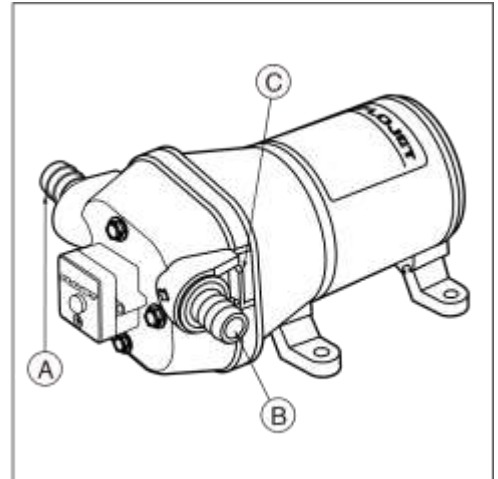
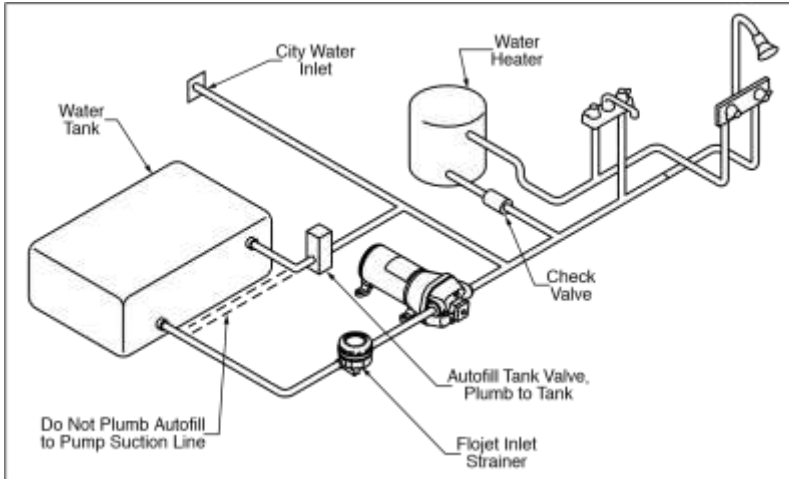

INSTALLATION

STEP 1

Remove shipping plugs from Quad pump ports. Some water from factory testing may spill out.

STEP 2

Install inlet A and discharge B port connectors. Firmly push slide clips C forward to lock port connectors in place.

STEP 3

Slide rubber mounts fully into 4 mounting tracks.

STEP 4

Mount pump vertically, with pump head down or horizontally in an accessible location. If mounting vertically, motor up, attach motor mounts first then pump head mounts, while supporting weight of pump.

STEP 5

Use 1/2" I.D. flexible hose (preferably braided or reinforced). Use hose clamps on the slip-on barb hose connectors.

STEP 6

Install a 3/8" I.D. hose for feed lines. Use high pressure hose on all city water lines.

STEP 7

Install a Flojet strainer in an accessible location (for inspection and cleaning) between the tank and pump inlet. This strainer or equivalent is required for pump warranty to be valid.

NOTE: Do not use with an accumulator tank.

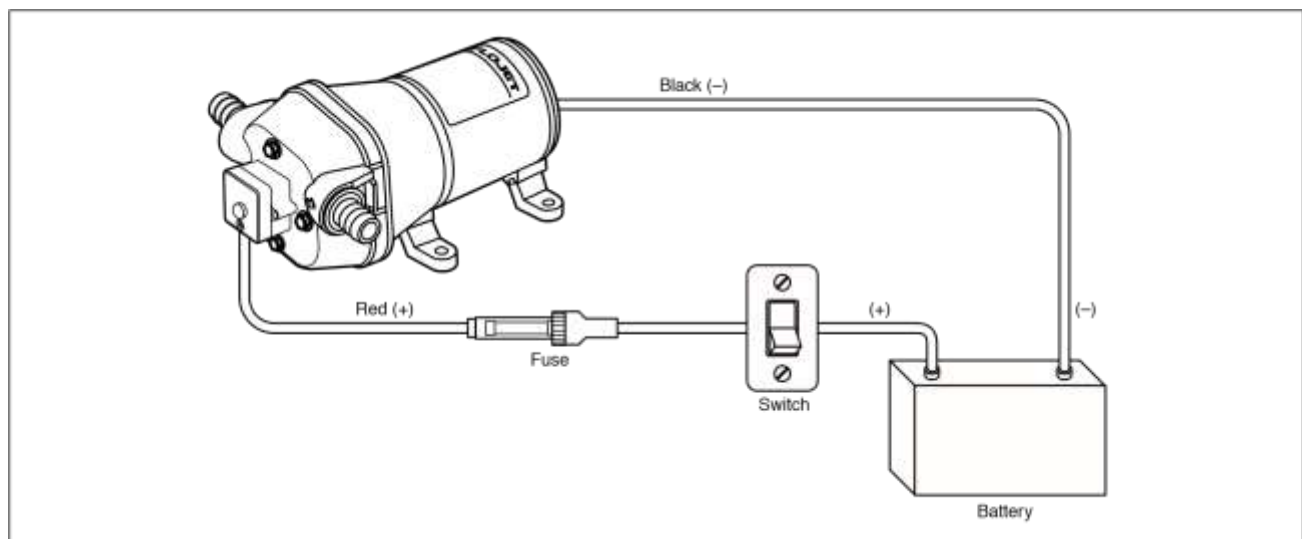

WIRING

STEP 1

Use 14 gauge stranded wire to 20', 12 gauge to 50', Install 10-15 amp fuse protection on the positive lead for from power source. the -143 model, use a 7 amp fuse for the -343 and a 5

STEP 2

Use a 10-15 amp rated on-off switch on the (+) positive (red) motor lead.

STEP 3

amp fuse for -443 model.

TROUBLESHOOTING

WARNING: BEFORE SERVICING PUMP, TURN OFF PUMP AND DRAIN WATER FROM SYSTEM!!

Failure to Prime - Motor operates, but no pump discharge

- Restricted intake or discharge line
- Air leak in intake line
- Debris in pump
- Punctured pump diaphragm (pump leaks)
- Crack in pump housing

Motor fails to turn on

- Loose wiring connection
- Pump circuit has no power
- Blown fuse
- Pressure switch failure
- Defective motor

Pulsating Flow

- Restricted pump delivery. Check discharge lines, fittings and valves for clogging or undersizing

Pump Fails to Turn Off After All Fixtures Are Closed

- Empty water tank
- Insufficient voltage to pump (low battery)
- Punctured pump diaphragm (pump leaks)
- Discharge line leak
- Defective pressure switch

Low Flow and Pressure

- Air leak at pump intake
- Accumulation of debris inside pump and plumbing
- Worn pump bearing (excessive noise)
- Punctured pump diaphragm (pump leaks)
- Defective motor

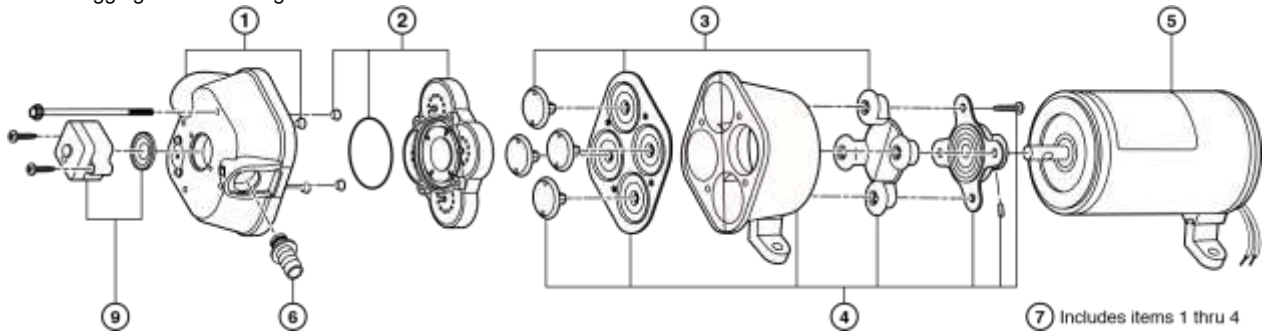

Quite often when a pump is worn or defective the one failed component has overburdened others. To avoid frequent aggravating repairs, Flojet offers service kit assemblies making repairs as quick and easy as possible.

DISASSEMBLE

Upper Housing

1. Remove switch (9). Disconnect switch wires.

Upper Housing

2. Loosen but do not remove four pump head screws and carefully remove upper housing assembly (1)
3. Inspect check valve (2) for debris
4. Reassemble new upper housing (1)

Check Valve Assembly

Follow steps 2 and 3

3. Replace check valve (2)
4. Reassemble upper housing (1)

Lower Housing, Diaphragm, Motor

Follow step 2, then slide rubber foot from mounting track.

3. Rotate lower housing (4) so mounting notch opening on lower housing exposes set screw which holds bearing housing to shaft.
4. Loosen this set screw by inserting wrench 1/8" Allen wrench into mounting notch opening. Then, slide lower housing (4) off motor shaft.

Diaphragm Cont'd

5. Loosen four cam piston screws with Phillips head screw driver and pull apart cam from inner pistons. (Pistons should always be replaced when a new diaphragm is installed.)

Motor Cont'd

5. Replace Motor

REASSEMBLE

Motor

1. Reassemble lower housing assembly (4) to motor. (Follow steps 4 to 10.)

Diaphragm

2. Lower housing is assembled with:

- Flat side of diaphragm and outer pistons facing motor
 - Hex stem of inner pistons must be aligned into hex holes in outer pistons (4).
 - Outer pistons must be aligned with alignment slots on cam assembly making sure screw holes align in cam assembly, otherwise diaphragm will leak.
3. Tighten cam piston screws partially, center piston in diaphragm, then tighten screws securely (18 in. lbs. torque)

Lower Housing

4. Reassemble lower housing assembly (4) to motor.

- Retighten set screw securely. Set screw head must be positioned facing motor covering seam (indentation). (Positioning of this screw is critical to avoid misalignment and subsequent diaphragm damage.) **Upper**

Housing, Check Valve

- Reassemble upper housing (1) and slide clips (8)
- Properly seat O-Ring in check valve assembly (2) and check if ferrules and screen are in place on upper housing (1)

- Install check valve (2) into upper housing (1) and push in.
- Assemble on to lower housing (4), align 4 screws on to motor by rotating lower housing (4) if necessary to align feet.
- Tighten screws evenly to 30 in. lbs. torque. **Pressure Switch**
- Place switch against front of pump (9), insert screws and take care not to cross thread or strip out threads in housing.
- Reconnect wires.

AUTOMATIC WATER SYSTEM PUMP SERVICE PARTS

KEY#	DESCRIPTION	MODEL#		
		4405-143	4405-343	4405-443
0	Service Kit*	20409-043	20409-043	20409-043
1	Upper Housing With Clips	20404-002	20404-002	20404-002
2	Check Valve Assembly	20407-030	20407-030	20407-030
3	Diaphragm Assembly (includes screws)	20403-040	20403-040	20403-040
4	Lower Housing Assembly	20419-001	20419-001	20419-001
5	Motors	2009-073A	2019-023A	2049-025A
	Motors CE Models	R2009-073A	R2019-023A	—
6	Ports - 1/2 Barb (pair)	20381-002	20381-002	20381-002
	Ports - 1/2 Qest (pair)	20381-000	20381-000	20381-000
	Ports - 3/4 Barb (pair)	20381-006	20381-006	20381-006
7	Pump Head Assembly	20406-003A	20406-003A	20406-003A
8	Side Clips (pair)	20408-000	20408-000	20408-000
9	Pressure Switch Assembly	02090-104	02090-104	02090-104

*Service Kit includes #2, #3, #8 and drive cam assembly.

ACCESSORIES QUICK CONNECT PORT SYSTEM

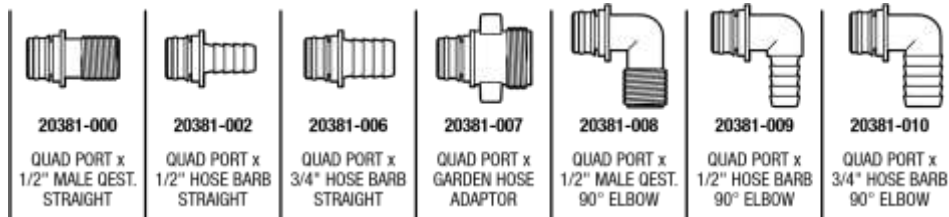

The above part numbers are packaged with 2 fittings per bag.

STRAINERS

Pump Series	Strainer Number	Inlet	Outlet	Screen
4405-XXX	1740-012	1/2 Barb	Quad Port	40 Mesh
	1740-002	1/2 Barb	1/2 Barb	40 Mesh
	1740-004	1/2 M Qest	1/2 M Qest	40 Mesh
	1740-014	1/2 M Qest	Quad Port	40 Mesh

WARRANTY

FLOJET warrants this product to be free of defects in material and/or workmanship for a period of two years after purchase by the customer from FLOJET. During this two year warranty period, FLOJET will at its option, at no charge to the customer, repair or replace this product if found defective in material or workmanship, with a new or reconditioned product, but not to include costs of removal or installation.

This is only an overview of our limited warranty. If you would like a copy of our warranty, please call or write FLOJET.

RETURN PROCEDURE

Prior to returning any product to FLOJET, call customer service for an authorization number. This number must be written on the outside of the shipping package. Place a note inside the package with an explanation regarding the reason for return as well as the authorization number. Include your name, address and phone number.

U.S.A.
Flojet
20 Icon
Foothill Ranch, CA 92610-3000
Tel: (949) 859-4945
Fax: (949) 859-1153

UNITED KINGDOM
Jabsco/Flojet
Bingley Road, Hoddesdon
Hertfordshire EN11 OBU
Tel: +44 (0) 1992 450145
Fax: +44 (0) 1992 467132

CANADA
Fluid Products Canada
55 Royal Road
Guelph, Ontario N1H 1T1
Tel: (519) 821-1900
Fax: (519) 821-2569

JAPAN
NHK Jabsco Company Ltd. 3-
21-10, Shin-Yokohama
Kohoku-Ku, Yokohama, 222
Tel: 045-475-8906
Fax: 045-475-8908

GERMANY
Jabsco GmbH
Oststrasse 28
22844 Norderstedt
Tel: +49-40-53 53 73-0
Fax: +49-40-53 53 73-11

Flojet



ITT Industries
Engineered for life