

POWER SMOKELESS GRILL™



Owner's Manual

Save These Instructions – For Household Use Only

Models: GR-200, GR-200-5, GR-1200, GRXJ1500, and XJ-12872

When using electrical appliances, basic safety precautions should always be followed. Do not use The **Power Smokeless Grill™** until you have read this manual thoroughly.

Visit TristarCares.com for tutorial videos, product details, and more.
Guarantee Information Inside



Before You Begin

It is very important that you read this entire manual, ensuring that you are totally familiar with its operation and precautions.

Table of Contents

| | |
|--|-----------|
| <i>IMPORTANT SAFEGUARDS</i> | 4 |
| <i>Parts & Accessories</i> | 6 |
| <i>Using the Control Panel</i> | 7 |
| <i>General Operating Instructions</i> | 8 |
| <i>Cooking Chart</i> | 9 |
| <i>Troubleshooting</i> | 10 |
| <i>Cleaning & Storage</i> | 10 |
| <i>60-Day Guarantee</i> | 11 |

IMPORTANT SAFEGUARDS

When using electrical appliances, basic safety precautions should always be followed, including:

- **READ** all instructions.
- **DO NOT TOUCH** hot surfaces. Use handles or knobs.
- **NEVER IMMERSE** the Main Unit Housing, which contains electrical components and heating elements, in water. Do not rinse under the tap.
- **TO AVOID ELECTRICAL SHOCK, DO NOT** put liquid of any kind into the Main Unit Housing containing the electrical components.
- This appliance has a three-prong plug. This plug is intended to fit into a polarized outlet only one way. **DO NOT ATTEMPT** to modify the plug in any way.
- **MAKE SURE** the appliance is plugged into a wall socket.
- While cooking, the internal temperature of the Unit reaches several hundred degrees Fahrenheit. **TO AVOID PERSONAL INJURY**, never place hands inside the Unit unless it is thoroughly cooled.
- This appliance is **NOT INTENDED FOR USE** by persons with reduced physical, sensory, or mental capabilities or a lack of experience and knowledge unless they are **UNDER THE SUPERVISION** of a responsible person or have been given proper instruction in using the appliance. This appliance is **NOT INTENDED FOR USE** by children. Close supervision is necessary when any appliance is used near children.
- Unplug from outlet when not in use and before cleaning. Allow to cool before putting on or taking off parts, and before cleaning the appliance
- When cooking, **DO NOT PLACE** the appliance against a wall or against other appliances. Leave |at least 5 in. free space on the back and sides and above the appliance. Do not place anything on top of the appliance.
- **DO NOT USE** this Unit if the plug, the Power Cable, or the appliance itself is damaged in any way. The use of accessory attachments not recommended by the appliance manufacturer may cause injuries.
- **DO NOT PLACE** The Unit on stove top surfaces. Do not let cord hang over edge of table or counter, or touch hot surfaces.
- **DO NOT USE** outdoors.
- If the power cord is damaged, **YOU MUST HAVE IT REPLACED** by the manufacturer, its service agent, or a similarly qualified person in order to avoid hazard.
- Keep the appliance and its Power Cable **OUT OF THE REACH** of children when it is in operation or in the cooling process.
- **KEEP THE POWER CORD AWAY** from hot surfaces. **DO NOT PLUG** in the Power Cable or operate the Unit controls with wet hands.
- **NEVER CONNECT** this appliance to an external timer switch or separate remote-control system.
- **NEVER USE** this appliance with an extension cord of any kind. A short power-supply cord (or detachable power-supply cord) is provided to reduce the risk of becoming entangled in or tripping over a longer cord.
- **DO NOT OPERATE** the appliance on or near combustible materials, such as tablecloths and curtains.
- **DO NOT USE** the **Power Smokeless Grill** for any purpose other than described in this manual.
- **NEVER OPERATE** the appliance unattended.
- **WEAR OVEN MITTS** when handling hot components or touching hot surfaces.
- Should the Unit emit black smoke, **UNPLUG IMMEDIATELY** and wait for smoking to stop before removing oven contents.
- Always operate the appliance on a horizontal surface that is level, stable, and noncombustible.
- This appliance is intended for normal household use only. It is not intended for use in commercial or retail environments.
- If the **Power Smokeless Grill** is used improperly or for professional or semiprofessional purposes or if it is not used according to the instructions in the user manual, the warranty becomes invalid and the manufacturer will not be held liable for damages.

IMPORTANT SAFEGUARDS

- Extreme caution must be used when moving an appliance containing hot oil or other hot liquids.
 - Always attach plug to appliance first, then plug cord in the wall outlet. To disconnect, turn off, then remove plug from wall outlet.
 - Always unplug the appliance after use.
 - Let the appliance cool for approximately 30 mins. before handling, cleaning, or storing.
 - The Glass Lid and handle get very hot. Always use oven mitts.
-

SAVE THESE INSTRUCTIONS - FOR HOUSEHOLD USE ONLY.

Electric Power

If the electrical circuit is overloaded with other appliances, your new Unit may not operate properly. This Unit should be operated on a dedicated electrical circuit.

Shut-Off

You can manually shut off the appliance by pressing the Power Button at any time during cooking.

Caution

- Do not operate Unit without the Grill or Griddle Plate.
- Do not place lid on the Unit without the Grill or Griddle Plate.

Electromagnetic Fields

This appliance complies with all standards regarding electromagnetic fields. If handled properly and according to the instructions in this user manual, the appliance is safe to use based on scientific evidence available today.



WARNING:

For California Residents

This product can expose you to Bisphenol A, which is known to the State of California to cause birth defects or other reproductive harm. For more information, go to www.P65Warnings.ca.gov.

Unit Specifications

| Model Number | Supply Power | Rated Power |
|--------------|--------------|-------------|
| GR-200 | AC 120V 60Hz | 1200W |
| GR-200-5 | AC 120V 60Hz | 1500W |
| GR-1200 | AC 120V 60Hz | 1200W |
| GRXJ1500 | AC 120V 60Hz | 1500W |
| XJ-12872 | AC 120V 60Hz | 1500W |

Parts & Accessories

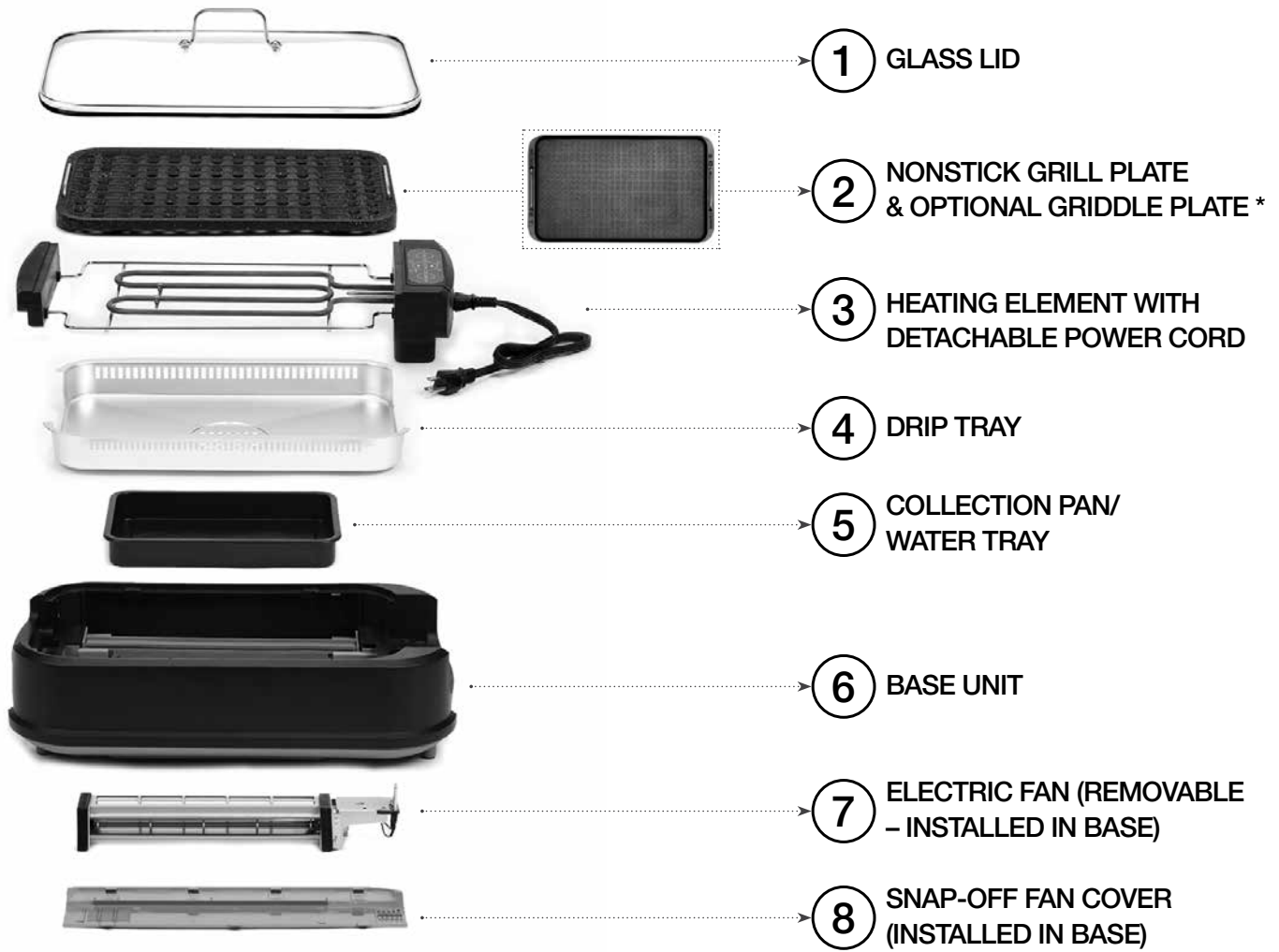

NOTE: Unpack all listed contents from packaging. Contents vary by model. Please remove any clear or blue protective film on the components before use.

NOTE: Ensure that your *Power Smokeless Grill* has been shipped with the components that you ordered (some accessories may be sold separately). Check everything carefully before use. If any part is missing or damaged, do not use this product. Contact shipper using the customer service number located in the back of the owner's manual.

NOTE: This unit has been designed and engineered to reduce the smoke and visible vapors usually associated with grilling to a minimum. Delivers outdoor results indoors.

Caution

Wait for all components to cool thoroughly after use before disassembling. Always handle hot components with oven mitts while cooking.

Using the Control Panel

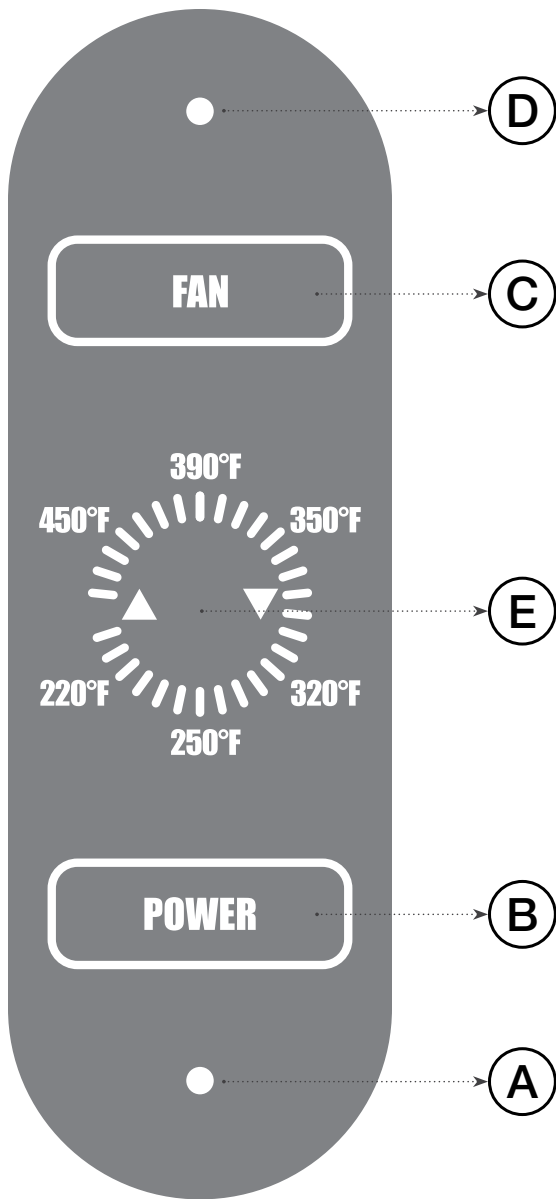

1. Plug the Power Cord (3) into an outlet. LED Light (A) will blink on and off.
2. Select Power Button (B), and LED (A) will stay lit.
3. Select Fan Button (C). Fan will run and Fan LED (D) will light up.
NOTE: Fan should be kept running throughout the grilling process to prevent grease build up.
4. Use Temperature Arrows (E) to adjust cooking temperature from 220° F to 450° F.
NOTE: You may raise or lower the cooking temperature at any time during the cooking process. To keep food warm, set the temperature between 220° F and 250° F.
5. When you are finished grilling, press the Power and Fan Buttons to shut down the Unit. Unplug the Power Cord and allow unit to cool fully before disassembling for cleaning.

Special Features

- Smokeless Grill with Built-In Fan
- Silicon-Sealed Lid
- Heats Up Quickly and Maintains Constant Temperature
- Dishwasher-Safe Parts and Easy to Clean
- Heats up to 450° F
- Nonstick Coating

General Operating Instructions

Before First Use

- Remove all packing materials, labels, and stickers.
- Hand wash the Glass Lid, Nonstick Grill Plate, Drip Tray, and Collection Pan with warm, soapy water.
- Wipe the inside and outside of the Base Unit with a clean, moist cloth. **NEVER** wash or submerge the Heating Element, Electric Fan, or Base Unit in water or liquid of any kind.
- Finally, heat up Unit for a few minutes to burn off any residue.

Using the Power Smokeless Grill

1. Place the appliance on a stable, level, horizontal, and heat-resistant surface.
2. Assemble the Unit as shown on page 6.
3. Add about 2 cups water to the Collection Pan.
4. Leave ample air space on all sides of the Unit to facilitate air flow.
5. Plug the Power Cord into a dedicated outlet.
6. If you are starting with a cold grill, you may preheat the grill using a medium or high heat setting for 4–6 mins.
7. Prepare and season your food according to your favorite recipe. You may spray or wipe the Grill Plate's cooking surface with cooking oil.
8. Select the cooking temperature, add the food, put the Lid* in place, and grill to your personal taste. Turn the food as needed.

* Cooking with the Glass Lid on the Unit is recommended because it maintains the cooking temperature, seals in flavor, and prevents splatter.

CAUTION: The Glass Lid and handle get very hot. Always use oven mitts.

Removing the Electric Fan

If you are thoroughly cleaning the Base Unit with water and detergents, remove the Electric Fan.

When reinserting the Fan, make sure to insert the two-prong connection into the receptacle.

CAUTION: Unplug Unit before removing fan.

Fan blades are sharp; use care when removing and reinserting.

1. Turn over the Base Unit.
2. Slide and remove the fan cover.
3. Lift the Fan out of the Base Unit. You may need to press on the fan prongs to push the fan out if it will not lift out easily.

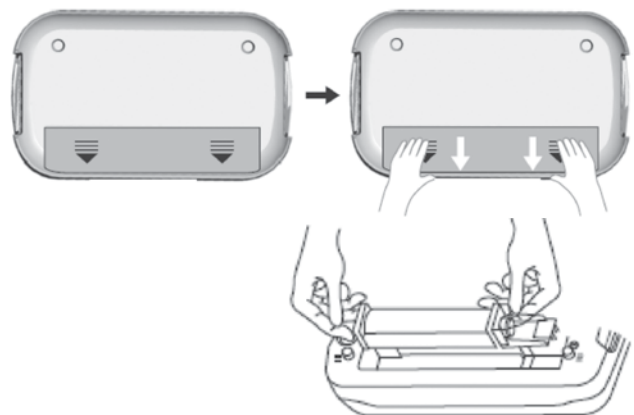

Switching Out the Grill and Griddle Plates

To remove the Grill Plate or Griddle Plate from the Power Smokeless Grill, use two hands to hold the two metal handles on each side of the Plate. Pull straight upward to remove the Plate from the Power Smokeless Grill.

NOTE: If the Power Smokeless Grill was recently used

to cook food, the Plate and its handles will be hot. Use oven mitts to handle the Plate.

To attach the new Plate, use two hands to hold the two metal handles on each side of the Plate. Lay the Plate evenly on top of the Heating Element and let go of the handles.

General Operating Instructions

Tips

- Be careful not to transfer germs from raw meat to cooked meat. Use separate utensils and platters for raw and cooked meat.
- Always marinate in a tightly covered nonmetal dish and turn the food occasionally. Be sure to refrigerate all meats while marinating.
- If leftover wet marinade is to be used as a sauce with the cooked food, be sure to place it in a small pan and heat to a rolling boil before serving to eliminate bacterial growth.
- Similar to a stove top frying pan, grease from high-fat foods, such as bacon or sausage, may splatter on the countertop. Protect the countertop as necessary.
- Before grilling, partially cook bone-in chicken, ribs, and uncooked smoked or fresh sausages for best results. If not partially cooked, these meats may become overbrowned on the outside before the center is done.
- To prevent scratching the coating, use only nonmetallic utensils. Do not cut food on the grill plate using sharp utensils, such as forks or knives, that can scratch the cooking surface.
- Do not use steel wool or other metal pads. They could leave coarse scratches. Always rinse thoroughly and dry immediately with a soft towel.

Cooking Chart

| Food Item | Time | Internal Temperature | It's Done When |
|--------------------|---------------------------|----------------------|----------------------|
| Fish | 12–15 mins. (1-in. thick) | 155° F | Opaque/Flaky Texture |
| Shrimp | 2–4 mins. (per side) | 155° F | Opaque & Red Edges |
| Chicken Drumsticks | 30–45 mins. | 176° F | Juice Runs Clear |
| Chicken Wings | 20–25 mins. | 176° F | Juice Runs Clear |
| Kabobs | 12–15 mins. | - | Your Preference |
| Steak | 3–9 mins. (per side) | 140° F–165° F | Your Preference |
| Pork Chops | 20–25 mins. | 160° F | No Pink Meat |
| Burgers | 10–15 mins. | 160° F | Your Preference |
| Sausages | 15–25 mins. | 160° F | No Pink Meat |
| Bacon | 1–2 mins. (per side) | NA | Crispy |

- Use a meat thermometer to check internal meat temperature.
- Cooking times are suggested and will vary depending on the thickness of the food and personal preferences. Foods can be grilled at maximum temperature. However you may wish to reduce the temperature for certain items. Low temperatures will keep foods warm once cooked.

Troubleshooting

If your Unit is not working properly:

- Make sure the Power Cord is plugged into an electrical socket.
- Make sure the Power Cord is properly connected to the Heating Element.
- Make sure you have set the temperature higher than 120° F.
- The Unit may not be able to draw enough operating power from the outlet. Try switching the Power Cord to an outlet that has no other appliances attached to it.
- If food is undercooked or overcooked, change the cooking time and temperature accordingly.
- If the Electric Fan is not working, the assembly may not be fully connected. Disassemble the Unit and reattach the Fan component. Follow instructions on page 8.

Care & Cleaning

- Before cleaning, be sure to unplug the cord from the outlet. If necessary, wipe the cord with a damp cloth.
- Allow the appliance to cool completely before cleaning. The Grill Plate, Drip Tray, Collection Pan, and Glass Lid can be placed in the bottom rack of the dishwasher or washed by hand. The Base Unit can be washed by hand with a warm, damp cloth and mild cleaning liquid. For more thorough cleaning of the Base Unit, remove the Electric Fan.
- Always be sure to wash the Grill surface after each use to remove any grease that may have accumulated. To keep grease from dripping outside of the base, always ensure that you are using your Grill on a level surface and that the Drip Tray is completely clear of food particles.
- Do not use scouring pads or harsh cleaners on this unit. If necessary, use a nylon bristle brush or plastic scrubbing pad.
- Any other servicing should be performed by an authorized service representative.

POWER SMOKELESS GRILL™

60-Day Money-Back Guarantee

If you decide that you don't love this product, your order is covered by our 60-Day Money-Back Guarantee. You have 60 days from the day you receive your product to request a replacement product or refund of the purchase price minus processing and handling fees.

To receive a refund or replacement, you must return the product to us at your expense. To return the product, call customer service at 1-973-287-5129 and request a return merchandise authorization number. Pack the product carefully and include in the package a note with (1) your name, (2) mailing address, (3) phone number, (4) email address, (5) reason for return, and (6) proof of purchase or order number, and (7) specify on the note whether you are requesting a refund or replacement. Write the return merchandise authorization number on the outside of the package.

Send the product to the following return address:

Power Smokeless Grill
Tristar Products
500 Returns Road,
Wallingford, CT 06495

POWER SMOKELESS GRILL™

We are very proud of the design and quality
of our *Power Smokeless Grill™*.

This product has been manufactured to the highest standards.
Should you have any questions, our friendly customer service
staff is here to help you.

973-287-5129



Distributed by:
Tristar Products, Inc.
Fairfield, NJ 07004
© 2019 Tristar Products, Inc.
Made in China
PSG_IB_ETL_TP_ENG_V8_190226

