

Model: Cora

lėvoit

Natural Himalayan Salt Lamp

Questions or Concerns?

Please contact us Mon - Fri 9:00AM - 5:00PM PST
at (888) 726 - 8520 or email support@levoit.com

Thank You.

Thank you for purchasing the Cora Natural Himalayan Salt Lamp by Levoit. We are dedicated to providing our customers with quality products for building a better living. Should you have any questions or concerns about using your new product, feel free to reach out to our helpful customer support team at (888)-726-8520 or by email at support@levoit.com. We hope you enjoy your new product!



Table of Contents

Safety Information	5
Main Functions	6
Set-Up	7
Operation	7
Cleaning & Maintenance	9
Specifications	10
Customer Support	11
Warranty Information	12



Safety Information

IMPORTANT: Please read, understand, and comply with all of the instructions provided in this manual before using the device. Failure to comply with the instructions given in this manual and/or using the device in ways other than the ones mentioned in this manual may result in serious injury and/or damage the product.

- Keep out of reach of children.
- Avoid exposure to high-temperature sources, direct sunlight and moisture. The lamp is for indoor use only.
- **DO NOT** strike or drop the lamp.
- To avoid damage, move and handle with care.
- **DO NOT** wash with water or detergents. Do not immerse in any form of liquid.
- **DO NOT** place the salt lamp near any electrical appliances. The natural evaporation may cause humidity or damage to other appliances.
- Due to the nature of salt, each crystal varies in color, shape, size, and weight.
- To protect the surface in which the lamp is placed, place a cloth or coaster under the lamp's base.
- If the salt crystal surface becomes moist, set the lamp to high and leave the lamp on to allow the salt crystals to dry.
- **DO NOT** replace the bulb while the lamp is connected to a power source.
- Although the salt crystals are non-toxic, they are not made for consumption and may present a choking hazard.



Main Functions

Function Diagram

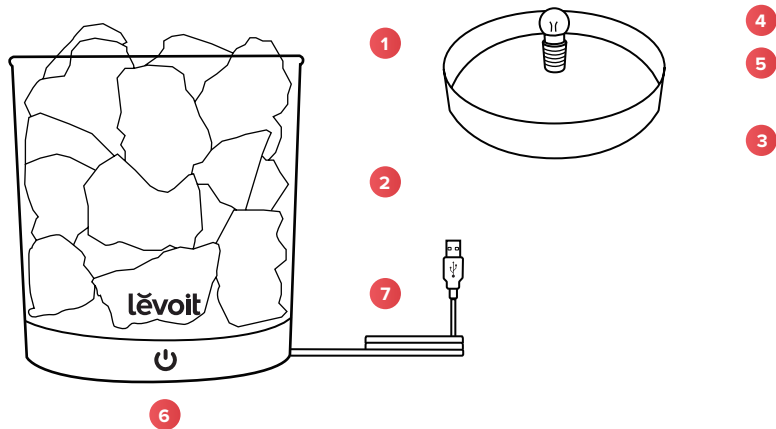

1. Salt Crystals
2. Lamp Housing
3. Base
4. Bulb
5. Bulb Socket

6. Power Button
7. USB Power Cable



Set-up

Remove the protective lining from inside the lamp. Then open the bag of salt crystals and place them carefully into the lamp housing, evenly distributing them around the bulb. The light bulb already comes pre-installed and is covered by the lamp housing.

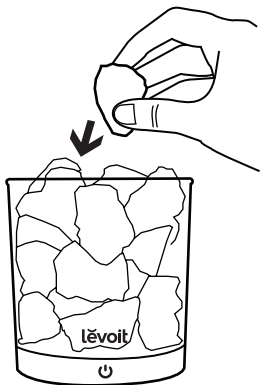

Operation

1. Place the salt lamp on a hard, flat surface.
2. Connect the USB cable into the included power adapter. Plug the power adapter into an electrical outlet.
3. Tap the power button to turn on the lamp.
4. Hold the power button to adjust the lamp's brightness. Release at the desired brightness setting.



5. Tap the power button once again to turn off the lamp.

NOTE:

- When you first turn on the lamp, its default brightness level will be at maximum.
- The lamp may turn off while dimming it. If this happens, simply press and hold the power button to turn the lamp back on.
- The lamp can be plugged into any device that has a standard 5V/1A USB output including computers, laptops, speakers and other power adapters.

Light Bulb Replacement

1. Unplug lamp from power source.
2. Carefully, remove the lamp's salt crystals and place them in a safe, dry place.
3. Flip the housing over and remove the three screws attaching the base to the housing.



4. Gently pull on the power cord near the base to remove the base from the housing.

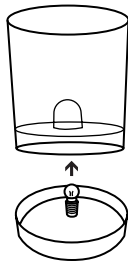

5. Remove the bulb from the socket by gently twisting it counter-clockwise.

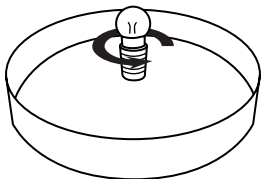

6. Install a new E10 2.5W bulb.
7. Place the base back into the housing and replace all of the screws on the base.
8. Flip the housing back over and replace all of the salt crystals.

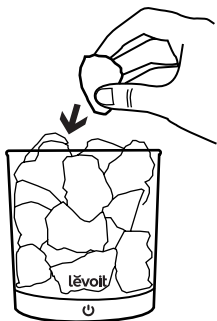

Cleaning & Maintenance

- Regularly dust off the salt crystals with a dry clean cloth.
- Do not wash or clean with water or liquid detergents.
- If not in use for a long period of time, store the lamp in a cool and dry environment, covering the crystals with a plastic bag.
- The lamp may naturally moisten in humid environments. If used in a humid environment, keep the lamp lit for several hours for it to naturally dry out.
- If the salt crystals become moist, gently pat down them with a dry cleaning cloth.



Specifications

AC Adapter Input	100-240V 50/ 60Hz
DC Input	DC 5V
Max Power	2.5W
Weight	1Kg
Size	4.3 x 4.5in. (110 x 115mm)
Power Cord Length	62.9in. (1.6m)

Package Contents

- 1 x Natural Himalayan Salt Lamp
- 1 x AC Power Adapter
- 3 x E10 2.5W Light Bulb (one pre-installed)
- 1 x User Manual



Customer Support

Should you encounter any issues or have any questions regarding your new product, feel free to contact our helpful Customer Support Team.

We're here for you.

Levoit Corporation

1202 N Miller Street, Suite A
Anaheim, CA 92806

Toll-Free: 888.726.8520
Email: support@levoit.com

Support Hours

Monday - Friday: 9:00am - 5:00pm PST

**Please have your order number ready before contacting customer support.*



Warranty Information

Terms & Policy

Levoit warrants all products to be of the highest quality in material, craftsmanship and service for a minimum of 1 year, effective from the date of purchase. Warranty lengths may vary between product categories. For specific warranty terms, please refer to your product's listing page.

Under the limited warranty, Levoit will replace any product found to be defective due to manufacturer flaws based on eligibility; refunds are available within the first 30 days of purchase. This warranty extends only to personal use and does not extend to any product that has been used for commercial, rental, or any other use in which the product is not intended for. There are no warranties other than the warranties expressly set forth with each product.

This warranty is non-transferrable. Levoit is not responsible in any way for any damages, losses or inconveniences caused by equipment failure or by user negligence, abuse, or use noncompliant with the user manual or any additional safety, use, or warnings included in the product packaging and manual.

This warranty does not apply to the following:

- Damage due to abuse, accident, alteration, misuse, tampering or vandalism.
- Improper or inadequate maintenance.
- Damage in return transit.

- Unsupervised use by children under 18 years of age.

Levoit and its subsidiaries assume no liability for damage caused by the use of the product other than for its intended use or as instructed in the user manual. Some states do not allow this exclusion or limitation of incidental or consequential losses so the foregoing disclaimer may not apply to you. This warranty gives you specific legal rights and you may also have other rights which may vary from state to state.

ALL EXPRESSED AND IMPLIED WARRANTIES, INCLUDING THE WARRANTY OF MERCHANTABILITY, ARE LIMITED TO THE PERIOD OF THE LIMITED WARRANTY.

Should your product prove defective within the specified warranty period, please return the defective unit in its original packaging with (1) an original copy of the invoice, (2) your order confirmation number, (3) and your warranty ID number.

To find out more about extending your warranty, visit www.levoit.com/warranty or contact customer support.

Date of Purchase: _____

Purchased From: _____

Order Number: _____



www.levoit.com