



SURFboard® SB8200 DOCSIS® 3.1 Cable Modem

User Guide, STANDARD Revision x.4

P/N 365-095-30000

CommScope copyrights and trademarks

© 2021 CommScope, Inc. All rights reserved.

No part of this content may be reproduced in any form or by any means or used to make any derivative work (such as translation, transformation, or adaptation) without written permission from CommScope, Inc. and/or its affiliates (“CommScope”). CommScope reserves the right to revise or change this content from time to time without obligation on the part of CommScope to provide notification of such revision or change. ARRIS and the ARRIS Logo are trademarks of CommScope, Inc. and/or its affiliates. All other trademarks are the property of their respective owners.

Wi-Fi Alliance[®], Wi-Fi[®], the Wi-Fi logo, the Wi-Fi CERTIFIED logo, Wi-Fi protected access[®] (WPA), the Wi-Fi Protected Setup logo, and WMM[®] are registered trademarks of Wi-Fi Alliance. Wi-Fi Protected Setup[™], Wi-Fi Multimedia[™], and WPA2[™] are trademarks of Wi-Fi Alliance.

CommScope provides this guide without warranty of any kind, implied or expressed, including, but not limited to, the implied warranties of merchantability and fitness for a particular purpose. ARRIS may make improvements or changes in the product(s) described in this manual at any time.

The capabilities, system requirements and/or compatibility with third-party products described herein are subject to change without notice.

Safety and regulatory information

Read all safety and regulatory information before installing your device and setting up your home network connection.

Important safety instructions

Read this before you begin — When using your equipment, basic safety precautions should always be followed to reduce the risk of fire, electric shock, and injury to persons, including the following:

- Read all the instructions listed here and/or in the user manual before you operate this device. Give attention to all safety precautions. Retain the instructions for future reference.
- This device must be installed and used in strict accordance with manufacturer's instructions, as described in the user documentation that is included with the device.
- Comply with all warning and caution statements in the instructions. Observe all warning and caution symbols that are affixed to this device.
- To prevent fire or shock hazard, do not expose this device to rain or moisture. The device must not be exposed to dripping or splashing. Do not place objects filled with liquids, such as vases, on the device.
- This device was qualified under test conditions that included the use of the supplied cables between system components. To ensure regulatory and safety compliance, use only the provided power and interface cables and install them properly.
- Different types of cord sets may be used for connections to the main POWER supply circuit. Use only a main line cord that complies with all applicable device safety requirements of the country of use.
- Installation of this device must be in accordance with national wiring codes and conform to local regulations.
- Operate this device only from the type of power source indicated on the device's marking label. If you are not sure of the type of power supplied to your home, consult your dealer or local power company.
- Do not overload outlets or extension cords, as this can result in a risk of fire or electric shock. Overloaded AC outlets, extension cords, frayed power cords, damaged or cracked wire insulation, and broken plugs are dangerous. They may result in a shock or fire hazard.
- Route power supply cords so that they are not likely to be walked on or pinched by items placed upon or against them. Pay attention to cords where they are attached to plugs and convenience receptacles; and examine the point where they exit from the device.
- Place this device in a location that is close enough to an electrical outlet to accommodate the length of the power cord.
- Place the device to allow for easy access when disconnecting the power cord of the device from the AC wall outlet.

- Do not connect the plug into an extension cord, receptacle, or other outlet unless the plug can be fully inserted with no part of the blades exposed.
 - Place this device on a stable surface.
 - Avoid damaging the device with static by touching the coaxial cable when it is attached to the earth-grounded coaxial cable-TV wall outlet.
 - Always first touch the coaxial cable connector on the device when disconnecting or reconnecting the Ethernet cable from the device or user's PC.
 - Installation of an AC surge protector in the AC outlet to which this device is connected is recommended. This is to avoid damaging the device by local lightning strikes and other electrical surges.
 - Postpone installation until there is no risk of thunderstorm or lightning activity in the area.
 - Avoid using a telephone (other than a cordless type) during an electrical storm. There is a remote risk of electric shock from lightning. For added protection, unplug the device from the wall outlet and disconnect the cables to avoid damage to this device from lightning and power surges.
 - Do not use this product near water. For example, near a bathtub, washbowl, kitchen sink, laundry tub, swimming pool, or in a wet basement.
 - Do not use the telephone to report a gas leak located near the leak.
 - Do not cover the device or block the airflow to the device with any other objects. Keep the device away from excessive heat and humidity and keep the device free from vibration and dust.
 - Wipe the device with a clean, dry cloth. Never use cleaning fluid or similar chemicals. Do not spray cleaners directly on the device or use forced air to remove dust.
 - For added protection, unplug the device from the wall outlet and disconnect the cables to avoid damage to this device during lightning activity or power surges.
-  **CAUTION:** To reduce the risk of fire, use only No. 26 AWG or larger (e.g., 24 AWG) UL Listed or CSA Certified Telecommunication Line Cord, or national equivalent.
- Upon completion of any service or repairs to this device, ask the service technician to perform safety checks to determine that the device is in safe operating condition.
 - Do not open the device. Do not perform any servicing other than that contained in the installation and troubleshooting instructions. Refer all servicing to qualified service personnel.
 - This device should not be used in an environment that exceeds 104° F (40° C).

SAVE THESE INSTRUCTIONS



Note: To CATV system installer — This reminder is provided to call the CATV system installer's attention to Section 820.93 of the National electric code, which provides guidelines for proper grounding and, in particular, specifies that the coaxial cable shield must be connected to the grounding system of the building, as close to the point of cable entry as practical.

FCC statements

FCC Interference statement

This equipment has been tested and found to comply with the limits for a Class B digital device, pursuant to part 15 of the FCC Rules. These limits are designed to provide reasonable protection against harmful interference in a residential environment. This equipment generates, uses, and can radiate radio frequency energy and, if not installed and used in accordance with the instructions, may cause harmful interference to radio communications. However, there is no guarantee that interference will not occur in a particular installation. If this equipment does cause harmful interference to radio or television reception, which can be determined by turning the device off and on, the user is encouraged to try to correct the interference by one or more of the following measures:

- Increase the separation between the device and receiver.
- Connect the equipment into an outlet on a circuit different from that to which the receiver is connected.
- Consult the dealer or an experienced radio/TV technician for help.

This device complies with Part 15 of the FCC Rules. Operation is subject to the following two conditions: (1) This device may not cause harmful interference, and (2) This device must accept any interference received, including interference that may cause undesired operation.



CAUTION: Any changes or modifications not expressly approved by CommScope for compliance could void the user's authority to operate the equipment.

FCC Declaration of Conformity

CommScope, Inc, 3871 Lakefield Drive, Suwanee, GA 30024, declares that the SURFboard device complies with 47 CFR Parts 2 and 15 of the FCC rules as a Class B digital device.

FCC Radiation Exposure statement

This equipment complies with FCC radiation exposure limits set forth for an uncontrolled environment. To comply with the FCC RF exposure compliance requirements, the separation distance between the antenna and any person's body (including hands, wrists, feet and ankles) must be at least 8 inches (20.3 centimeters).

This transmitter must not be co-located or operating in conjunction with any other antenna or transmitter except those already approved in this filing.

The availability of some specific channels and/or operational frequency bands are country dependent and are firmware programmed at the factory to match the intended destinations. The firmware setting is not accessible by the end user.

Caring for the environment by recycling your ARRIS equipment



Please do not dispose of this product with your residential or commercial waste. Contact your local authorities for information about practices established for your region. If collection systems are not available, call ARRIS Technical Support at **1-877-466-8646** for assistance.

Table of contents

Chapter 1: Getting started	8
In the box.....	8
Additional items needed (not included).....	9
System requirements.....	9
Contact information.....	9
Chapter 2: Product overview	10
Front panel.....	10
Rear panel.....	11
Cable modem label.....	12
Chapter 3: Installing the cable modem	13
Connect the SB8200 to your computer.....	13
Establish an Internet connection.....	14
Chapter 4: Using the Web Manager	15
Start your SB8200 Web Manager.....	15
Web Manager screen options.....	16
Get help.....	17
Exit the Web Manager.....	18
Chapter 5: Monitoring your cable modem and protecting your connected network	19
Change the default user password.....	19
View the cable modem product information.....	20
View the cable modem network connection status.....	21
View the cable modem event log.....	22
Enable Link Aggregation Configuration.....	23
Reset the cable modem configuration settings.....	24
Reboot the cable modem.....	24
Exit the Web Manager.....	24
Chapter 6: Troubleshooting tips	25
Troubleshooting Solutions.....	25
Front panel LED icons and error conditions.....	26

Getting started





The ARRIS SURFboard® SB8200 DOCSIS 3.1 Cable Modem provides significantly higher downstream (send) and upstream (receive) Internet connection speeds over the broadband connection on your home or small business network. You use your SB8200 to directly connect a computer or router to your LAN through an Ethernet connection.

This guide provides instructions for installing and setting up your SB8200 to get it connected on your home or small business network, and also for viewing the operational status and network configuration settings of your SB8200.

In the box

Before installing your SB8200, check that the following items are included in the box. If any items are missing, please call ARRIS Customer Support at 1-877-466-8646 for assistance.

SB8200 package contents

Item		Description
SB8200 Cable Modem		High-speed DOCSIS 3.1 cable modem
Power Supply		Power cord for an electrical wall outlet connection
Software License & Regulatory Card		Contains safety and regulatory information, software license, and warranty for the cable modem
Support Information Card		Provides contact information for obtaining technical support assistance with any issues you may have with your SURFboard device

Item		Description
SB8200 Quick Start Guide		Provides basic instructions for installing the cable modem and setting up your network connection

Additional items needed (not included)

The following item is not included in the box and must be purchased separately, if needed.

- Coaxial (coax) cable, if one is not already connected to a cable wall outlet
- Ethernet cable

System requirements

- High-speed Internet access account
- Web browser access – Internet Explorer, Google Chrome, Firefox, or Safari
- Compatible operating systems:
 - Windows® 10
 - Windows 8
 - Windows 7 Service Pack 1 (SP1)



Note: Although older versions of Microsoft Windows operating systems are no longer specifically supported, they should still function with your SB8200.

- Macintosh® 10.4 or higher
- UNIX®
- Linux®

Contact information

For technical support and additional ARRIS product information:

- Visit the ARRIS Support website: www.arris.com/selfhelp
- Call ARRIS Technical Support: **1-877-466-8646**





Product overview

Front panel



SB8200 front view

SB8200 front panel LED icons

LED Icon	Flashing	On
 POWER	Not applicable — icon does not flash.	Green: Power is properly connected.
 RECEIVE	Scanning for a downstream (receive) channel Internet connection.	Green: Downstream channel is connected in DOCSIS 3.0 mode. Blue *: High-speed Internet connection with downstream channels in DOCSIS 3.1 mode.
 SEND	Scanning for an upstream (send) channel Internet connection.	Green: Upstream channel is connected in DOCSIS 3.0 mode. Blue*: High-speed Internet connection with upstream channels in DOCSIS 3.1 mode.
 ONLINE	Scanning for an Internet connection.	Green: Cable modem is connected to the Internet.

LED Icon	Flashing	On
----------	----------	----

*Blue: Indicates DOCSIS 3.1 operation (high-speed Internet access) which may not be available in all locations. Check with your service provider for availability in your area.

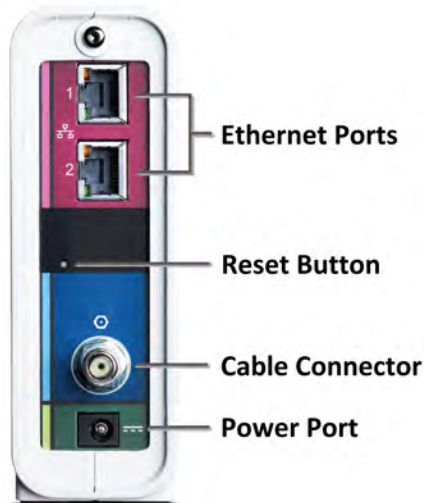

Rear panel

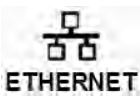

SB8200 rear view

SB8200 rear panel ports and connectors

Port Name	Description
	<p>Two Ethernet ports for RJ-45 network cable connections</p> <p>Green: LED indicates a GigE data connection is made</p> <p>Amber: LED indicates a 10/100 Mbps data connection is made</p>
Reset button	<p>Reset button located on the back of your SB8200 can be used to either reboot the cable modem or reset the cable modem configuration settings.</p> <p>To reboot (or restart) the cable modem:</p> <ol style="list-style-type: none"> 1. Insert the end of a paper clip or other small object with a narrow tip into the Reset opening on the back of your SB8200. 2. Press and hold the indented Reset button for three to four seconds only. 3. Remove the paper clip or small object from the Reset opening. <p>To reset the cable modem configuration back to the factory default settings:</p> <ol style="list-style-type: none"> 1. Insert the end of a paper clip or other small object with a narrow tip into the Reset opening on the back of your SB8200.

Port Name	Description
	<ol style="list-style-type: none"> Press and hold the indented Reset button for 10 seconds or until the front panel LEDs flash. Remove the paper clip or small object from the Reset opening. <p>See Reset the Cable Modem Configuration Settings (page 24) for more information on restoring the factory default settings on your SB8200.</p>
	Coaxial cable connector
	+12VDC Power connector Warning: To avoid any damage to your SB8200, only use the power supply provided in the box.

Cable modem label

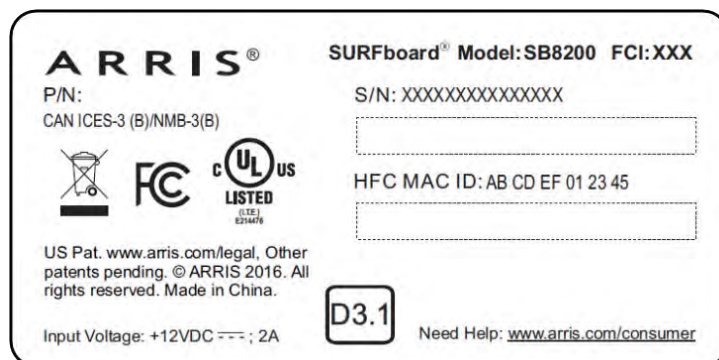

The cable modem label is located on the bottom of your SB8200. It contains specific cable modem ID that you may need when contacting your service provider or [ARRIS Technical Support](#) for assistance.

To receive Internet service, you will have to contact your service provider for assistance. You may have to provide the following information listed on the cable modem label:

- Model name (SB8200)
- Serial number (S/N)
- MAC address (HFC MAC ID)

Sample SB8200 cable modem label

Installing the cable modem

! **CAUTION:** This product is for indoor use only. Do not route the Ethernet cable(s) outside of the building. Exposure of the cables to lightning could create a safety hazard and damage the product.

You can set up your modem in one of the following ways.

- **Using the Surfboard Central app (SBC app):** It is recommended that you install and set up your cable modem using the SBC app. For details on how to set up, refer to the **SURFboard Central User Guide for Cable Modems** available on the <http://www.arris.com/selfhelp>.
- **Using client device (laptop/desktop):** If you are using your client device (laptop/Desktop) with a wired Ethernet connection, then see [Connect the SB8200 to your computer](#) (page 13).

Connect the SB8200 to your computer

Before installing your SB8200:

- Check with your service provider to ensure broadband cable service is available in your area.
- Choose a location in your home where your computer and cable modem are preferably near existing cable and electrical wall outlets.

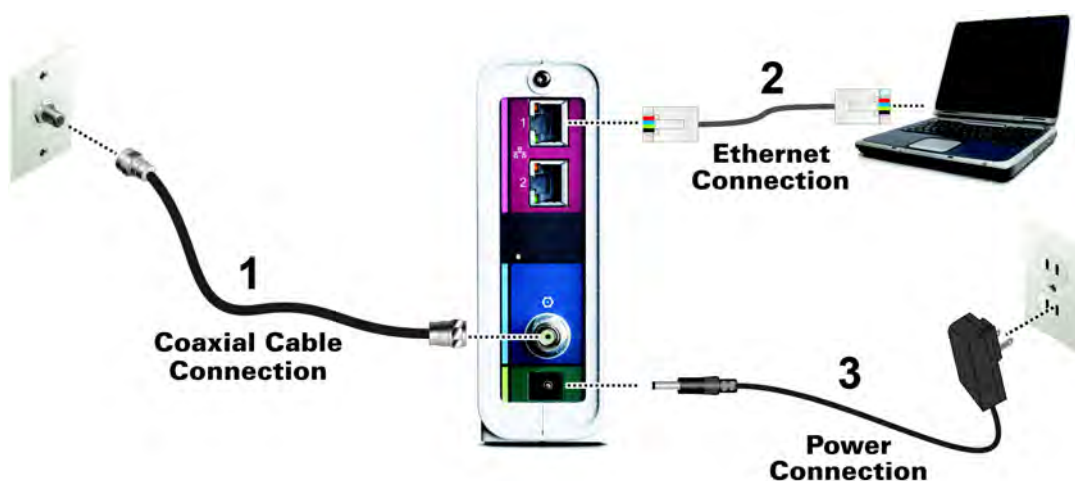

SB8200 connection diagram

1. Check that a coaxial cable is already connected to a cable wall outlet or RF splitter (not included).

2. Connect the other end of the coaxial cable to the Cable connector on the rear of your SB8200.

Use your hand to tighten the connectors to avoid damaging them.

3. Connect one end of an Ethernet cable to the Ethernet port on the rear of your SB8200 and the other end to the Ethernet port on your computer.
4. Connect the power cord to the Power port on the rear of your SB8200.
5. Plug the other end of the power cord into an electrical wall outlet that is not controlled by a wall switch.



Note: This automatically powers ON your SB8200. There may be up to a 15 second delay for the LED on the SB8200 front panel to light up after the power is connected.

Establish an Internet connection

Although your computer may already be configured to automatically access the Internet, you should still perform the following cable modem connectivity test to check that your devices were connected properly:

1. Power ON the computer connected to your SB8200, if it is turned off, and then log in.
2. Contact your service provider to activate (provision) your SB8200.
3. You may have to provide the HFC MAC ID listed on the cable modem label.



Note: Your service provider may allow for automatic activation which will automatically launch their special website when you open a web browser.

4. After your SB8200 is provisioned (or activated), open a web browser (such as Internet Explorer, Google Chrome, Firefox, or Safari) on the computer.
5. Type a valid URL (such as www.surfboard.com) in the Address bar and then press Enter.
6. The ARRIS SURFboard website should open. If it fails to open, please contact your service provider for assistance.
7. Check that the Power, Receive, Send, and Online front panel LEDs on your SB8200 light up in sequential order. See [Front panel](#) (page 10) for additional LED status information.
 - If all four LEDs did not light up Solid and you are not connected to the Internet, you may have to contact your service provider to reactivate your SB8200 or check for possible signal issues.
 - If you still cannot connect to the Internet, your SB8200 may be defective. Please contact ARRIS Technical Support at 1-877-466-8646 for assistance.

Using the Web Manager

The SB8200 Web Manager is available to view and monitor the SB8200 operational status and network configuration settings.

Start your SB8200 Web Manager

1. Open any Web browser on the computer connected to your SB8200.
2. Type the default LAN IP address, **192.168.100.1** in the Address bar and then press **Enter** to log onto the SB8200 and open the SB8200 Web Manager Login screen.
3. Type **admin** for the default login username (case-sensitive) in the **Username** field.
4. Type **password** (default login password; case-sensitive) in the **Password** field.



Note: If you are unable to login with the default login password **password**, then type the last eight digits of the serial number (S/N) available on your SB8200 cable modem label in the **Password** field.

5. Click **LOGIN** to open the SB8200 Web Manager.

The SB8200 Status screen displays.

Startup Procedure								
Procedure	Status	Comment						
Acquire Downstream Channel	753000000 Hz	Locked						
Connectivity State	OK	Operational						
Boot State	OK	Operational						
Configuration File	OK	"generic_30_bpi_plus_all_interfaces_TLV55_On_ARRIS_Merge.cm"						
Security	Enabled	BPI+						
DOCSIS Network Access Enabled								
Downstream Bonded Channels								
Channel Index	Lock Status	Width	Channel ID	Center Frequency	SNR/MER Threshold Value	Modulation/Profile ID	Corrected Codewords	Uncorrectable Codewords
1	Locked	4800 Ksym/sec	7	753000000 Hz	46.8 dBmV	QAM256	0	0
2	Locked	4800 Ksym/sec	2	711000000 Hz	47.3 dBmV	QAM256	0	0
3	Locked	4800 Ksym/sec	3	717000000 Hz	47.1 dBmV	QAM256	0	0
4	Locked	4800 Ksym/sec	4	723000000 Hz	47.5 dBmV	QAM256	0	0
5	Locked	4800 Ksym/sec	5	741000000 Hz	46.9 dBmV	QAM256	0	0
6	Locked	4800 Ksym/sec	6	747000000 Hz	46.8 dBmV	QAM256	0	0
7	Locked	4800 Ksym/sec	1	705000000 Hz	47.8 dBmV	QAM256	0	0
8	Locked	4800 Ksym/sec	8	759000000 Hz	47.0 dBmV	QAM256	0	0
Upstream Bonded Channels								
Channel Index	Lock Status	Width	Channel ID	Center Frequency	Transmit Level	Modulation/Profile ID		
1	Locked	ATDMA	49	307000000 Hz	43.9 dBmV	2		
2	Locked	TDMAANDATDMA	52	355000000 Hz	44.2 dBmV	4		
3	Locked	ATDMA	51	233000000 Hz	44.0 dBmV	2		
4	Locked	TDMAANDATDMA	50	185000000 Hz	43.7 dBmV	4		
Current System Time: Wed Aug 10 13:34:04 2016								

SB8200 status screen



Note: If you cannot access the HTML pages in the SB8200 Web Manager, please contact [ARRIS Technical Support](#) (page 9) for assistance.



Note: When logging in to the SB8200 Web Manager, you will be prompted to change the default login password (password). You will have the option to either keep the default password or change it (recommended). Please note that if you do not change the default login password, the same message will display every time you log in to the SB8200 Web Manager.

Web Manager screen options

Menu buttons and links

You can use the Web Manager buttons or links to view the status and network configuration screens for your SB8200.

- The SB8200 menu buttons are displayed along the top of the SB8200 Web Manager screen. To display a specific Web Manager screen, click the menu button.

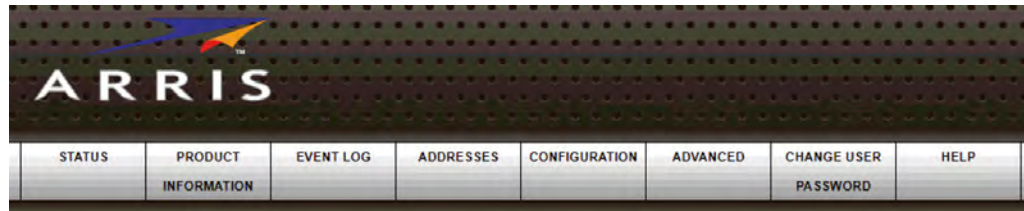

SB8200 Web Manager menu buttons

- The SB8200 menu links are displayed along the bottom of the SB8200 Web Manager screen. To display a specific Web Manager screen, click the menu link.

SB8200 Web Manager screen options

Screen Option	Function
Status	Provides the current operational status of the cable modem.
Product information	Provides the current hardware and software-related information for the cable modem.
Event log	Displays a listing of the time and actual events as they occur and are detected by the cable modem. This information may be useful to help diagnose and correct any problems that may occur with the cable modem.
Addresses	Provides the serial number and MAC addresses for the cable modem and computers connected on your home network.
Configuration	Provides the network connection frequency and channel ID information for the cable modem.
Advanced	Provides option to enable Ethernet Link Aggregation Configuration.
Change User password	Provides option to change the default password.
Help	Provides a brief description for each screen option and general troubleshooting tips.

Get help

The Help Pages screen provides a brief description for each web manager screen.

- Click the **Help** menu button or link on the SB8200 Web Manager screen to open the SB8200 Help Pages screen.

Help Pages	
Status	The Status page is the first page in the display. This page shows diagnostic information about the startup procedure, the downstream bonded channels, and the upstream bonded channels.
Product Information	The Product Information page displays information about the hardware version, software version, MAC address, serial number, system "up" time, and network registration status.
Event Log	The Event Log page provides a list of all the events that have occurred on the cable modem. Each event shows the time that it occurred, the priority of the event, and an event description.
Addresses	The Addresses Page provides information about the network connection between the Cable Modem and your computer. Also, it provides details about the connection between the Cable Modem and the service provider's computer systems.
Configuration	The Configuration page lists information about the upstream and downstream connection to the service provider.

For information regarding software licenses, acknowledgments and copyright notices for certain software packages and/or components that are used in this SB8200, please see the [Open Source Software Information](#).

SB8200 help pages screen

Exit the Web Manager

To exit the Web Manager:

- Click **Logout** in the upper right corner of the web browser window.

Monitoring your cable modem and protecting your connected network



Note: You may notice that some of the SB8200 Web Manager configuration settings may be blocked and cannot be modified. This may be due to some restrictions set up by your service provider for security reasons and also to prevent unauthorized modifications to certain cable modem configuration parameters. Contact your service provider to obtain special authorization to change the cable modem frequencies or other configuration settings.

Change the default user password

To change the default user password:

1. From your SB8200 Web Manager screen, click the **CHANGE USER PASSWORD**.
The Change User Password screen displays.

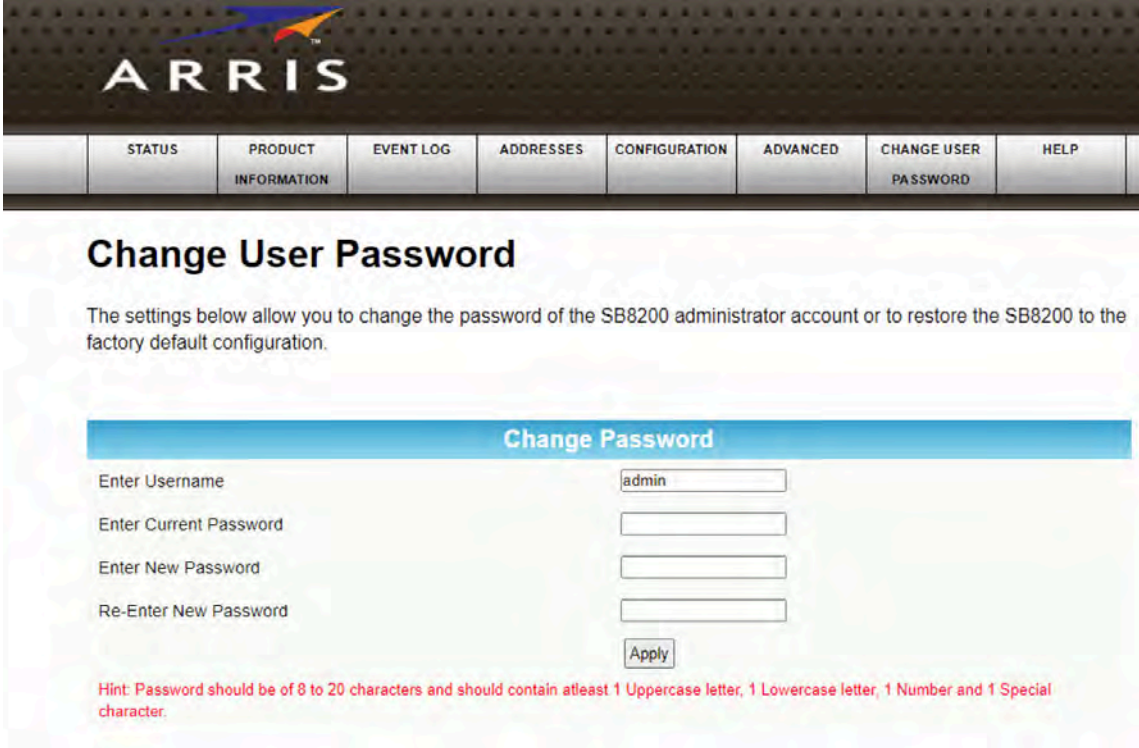

ARRIS

STATUS PRODUCT INFORMATION EVENT LOG ADDRESSES CONFIGURATION ADVANCED CHANGE USER PASSWORD HELP

Change User Password

The settings below allow you to change the password of the SB8200 administrator account or to restore the SB8200 to the factory default configuration.

Change Password

Enter Username:

Enter Current Password:

Enter New Password:

Re-Enter New Password:

Hint: Password should be of 8 to 20 characters and should contain atleast 1 Uppercase letter, 1 Lowercase letter, 1 Number and 1 Special character.

Change User Password settings screen

2. Enter the default username **admin** in the **Enter Username** field.
3. Enter the current (default) password **password** in the **Enter Current Password** field.
4. Enter your new password in the **Enter New Password** field.
5. Re-enter your new password in the **Re-Enter New Password** field.



Note:

Remember that passwords are case-sensitive and that you can use any combination of the following letters, numbers and special characters:

- Letters: A through (uppercase and lowercase) Z
- Numbers: 0 to 9
- Special characters: ! @ # \$ % & *

6. Click **Apply** to update your password.

The **Applying Changes...** message displays.



Note: The **Login Timeout** setting under the Other Settings section applies to the amount of inactivity time (in seconds) allowed before the Cable Modem Web Manager automatically logs out. The Login Timeout range is between **30** and **900** seconds.

7. Find a secure place to write down and keep your new password for future reference, if needed.

View the cable modem product information

The SB8200 Product Information screen displays the hardware and firmware versions, MAC address, serial number, and operation status for your SB8200.

To open the Product Information screen:

1. Open the SB8200 Web Manager (see [Start the SB8200 Web Manager](#) (page 15)).
2. Click the Product Information menu button or link on the SB8200 Web Manager screen.
3. Press **F5** to refresh or update the information on the screen.

Information	
Standard Specification Compliant	Docsis 3.0
Hardware Version	3
Software Version	D31CM-PEREGRINE-1.0.0.0-GA-01-NOSH
Cable Modem MAC Address	20:3D:66:AE:33:B5
Serial Number	G3JRW1445300019
Status	
Up Time	0 days 02h:15m:44s.00

SB8200 Product Information Screen

View the cable modem network connection status

The SB8200 Status screen displays the current connection status of your SB8200 and the downstream and upstream bonded channel connections for receive and send data transmissions. [Help](#) (page 17) is available to resolve any connection issues that resulted in a “failed” state during the cable modem startup.

To open the Status screen:

1. Open the SB8200 Web Manager (see [Start the SB8200 Web Manager](#) (page 15)).
2. Click the **Status** menu button or link on the SB8200 Web Manager screen.
3. The Status screen displays (see Figures 10 and 11).
4. Press **F5** to refresh or update the information on the screen.

Startup Procedure		
<u>Procedure</u>	<u>Status</u>	<u>Comment</u>
Acquire Downstream Channel	753000000 Hz	Locked
Connectivity State	OK	Operational
Boot State	OK	Operational
Configuration File	OK	"generic_30_bpi_plus_all_interfaces_TLV55_On_ARRIS_Merge.cm"
Security	Enabled	BPI+
DOCSIS Network Access Enabled		

SB8200 Status Screen (1 of 2)

Downstream Bonded Channels								
Channel Index	Lock Status	Width	Channel ID	Center Frequency	SNR/MER Threshold Value	Modulation/Profile ID	Corrected Codewords	Uncorrectable Codewords
1	Locked	4800 Ksym/sec	7	753000000 Hz	46.8 dBmV	QAM256	0	0
2	Locked	4800 Ksym/sec	2	711000000 Hz	47.3 dBmV	QAM256	0	0
3	Locked	4800 Ksym/sec	3	717000000 Hz	47.1 dBmV	QAM256	0	0
4	Locked	4800 Ksym/sec	4	723000000 Hz	47.5 dBmV	QAM256	0	0
5	Locked	4800 Ksym/sec	5	741000000 Hz	46.9 dBmV	QAM256	0	0
6	Locked	4800 Ksym/sec	6	747000000 Hz	46.8 dBmV	QAM256	0	0
7	Locked	4800 Ksym/sec	1	705000000 Hz	47.8 dBmV	QAM256	0	0
8	Locked	4800 Ksym/sec	8	759000000 Hz	47.0 dBmV	QAM256	0	0

Upstream Bonded Channels						
Channel Index	Lock Status	Width	Channel ID	Center Frequency	Transmit Level	Modulation/Profile ID
1	Locked	ATDMA	49	307000000 Hz	43.9 dBmV	2
2	Locked	TDMAANDATDMA	52	355000000 Hz	44.2 dBmV	4
3	Locked	ATDMA	51	233000000 Hz	44.0 dBmV	2
4	Locked	TDMAANDATDMA	50	185000000 Hz	43.7 dBmV	4

Current System Time: Wed Aug 10 13:34:04 2016

SB8200 Status Screen (2 of 2)

View the cable modem event log

The SB8200 generates a running log of the time and events or activities that it detects during the cable modem operation.



Note: This information may be useful to help diagnose and correct any problems that may occur with your cable modem. You may want to provide this information if you have to contact [ARRIS Technical Support](#) or your service provider for assistance.

To open the Event Log screen:

1. Open the SB8200 Web Manager (see [Start the SB8200 Web Manager](#) (page 15)).
2. Click the **Event Log** menu button or link on the SB8200 Web Manager screen.
3. Press **F5** to refresh or update the information on the screen.

Time	Priority	Description
2016-8-10,15.21.20	Warning	"Dynamic Range Window violation"
2016-8-10,12.47.34	Warning	"DHCP WARNING - Non-critical field invalid in response ;CM-MAC=20:3d:66:ae:33:b5;CMTS-MAC=00:30:b8:c6:3a:26;CM-QOS=1.1;CM-VER=3.1;"
2016-8-10,12.47.33	Critical	"DHCP FAILED - Request sent, No response;CM-MAC=20:3d:66:ae:33:b5;CMTS-MAC=00:30:b8:c6:3a:26;CM-QOS=1.1;CM-VER=3.1;"
2016-8-10,12.47.26	Warning	"Dynamic Range Window violation"
1970-1-1,0.0.47	Notice	"Honoring MDD; IP provisioning mode = Dual-Stack"

View the Cable Modem Configuration Settings

The SB8200 Cable Modem Configuration screen displays the downstream and upstream connection to the network. When your SB8200 successfully connects to the network, it stores the connection frequency to automatically connect whenever you have to log in to your SB8200.

To open the Configuration screen:

SB8200 event log screen

4. Open the SB8200 Web Manager (see [Start the SB8200 Web Manager](#) (page 15)).
5. Click the Configuration menu tab or link on the SB8200 Web Manager screen.



Note: The configuration settings on the SB8200 Configuration screen are read-only and cannot be modified. You will have to contact your service provider to obtain special authorization to change the cable modem frequencies and other configuration settings on your SB8200.

Configuration

The cable modem inside the CM8200A will automatically connect to the network. If you know the frequency and upstream channel that your cable system uses to communicate you may enter it below to help the modem find it more quickly. When the cable modem successfully connects to the network it will remember the frequency. Reboot the cable modem to initiate the new settings.

Configuration	
Downstream Frequency (Hz)	<input type="text" value="663000000"/>
Upstream Channel ID	<input type="text" value="25"/>
Downstream Frequency Plan	<input type="text" value="NorthAmerica"/>
Energy Efficient Ethernet	<input type="checkbox"/>

SB8200 configuration screen

Enable Link Aggregation Configuration

Ethernet Link Aggregation applies to various methods of combining (aggregating) multiple network connections in parallel in order to increase throughput beyond what a single connection could sustain, and to provide redundancy in case one of the links should fail.

To enable the Link Aggregation Configuration on your SB8200:

1. On your SB8200 Web Manager screen, click **ADVANCED** menu option.

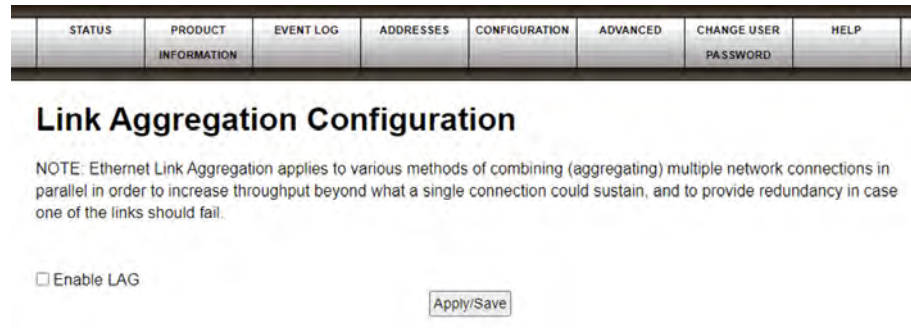

2. To enable Link Aggregation Configuration, click **Enable LAG** checkbox.
3. Click **Apply/Save**.

Reset the cable modem configuration settings

You can restore the factory default configuration settings on your SB8200. This process will delete the current SB8200 configuration settings and take approximately five to 30 minutes to complete. Your network connection will remain disabled until after the SB8200 configuration settings are restored.



Warning: This process will delete the current SB8200 configuration and replace it with the factory default settings.

To restore the factory default settings on your SB8200:

1. Insert the end of a paper clip or other small object with a narrow tip into the **Reset** opening on the back of your SB8200.
2. Press and hold the **Reset** button for 10 seconds or until the front panel LEDs flash.
3. Remove the paper clip or small object from the opening **Reset**.

Reboot the cable modem

To restart your SB8200:

1. Insert the end of a paper clip or other small object with a narrow tip into the **Reset** opening on the back of your SB8200.
2. Press and hold the indented **Reset** button for three to four seconds only, and then release.



Warning: If you press the Reset button for more than seven seconds, the cable modem configuration settings will be reset to the factory default settings.

Exit the Web Manager

To exit the Web Manager:

- Click **Logout** in the upper right corner of the web browser window.

Troubleshooting tips

If the solutions listed in the Troubleshooting Solutions table below do not solve your problem, please contact your service provider for assistance. Your service provider may ask for the status of the SB8200 front panel LEDs (see [Front panel LED icons and error conditions](#) (page 26) Front Panel LED Icons and Error Conditions) for more information).

You may have to reset the SB8200 configuration to the default factory settings if your SB8200 is not functioning properly. See [Reset the Cable Modem Configuration Settings](#) (page 24) for more information.

Troubleshooting Solutions





Modem Problem	Possible Solution
Power LED Icon is OFF	<p>Check the power connection from the cable modem to the electrical wall outlet.</p> <p>Check that the electrical wall outlet is working.</p> <p>Is the outlet controlled by a wall light switch?</p> <p>If so, disconnect the cable modem power cord and connect it to another electrical wall outlet that is not controlled by a wall light switch.</p>
Cannot Send or Receive Data	<p>Check each end of the coaxial cable connection on the cable modem and cable wall outlet.</p> <p>Use your hand to tighten each connector, if necessary.</p> <p>Check the Ethernet cable to make sure it is properly connected to the cable modem and computer.</p> <p>On the front panel, check the status of the LED icons and refer to Front Panel LED Icons and Error Conditions (page 26) to identify the problem.</p> <p>If you have cable television service, check your television to ensure your cable service is operating properly.</p> <p>If none of the above solutions resolves the problem, contact your service provider or call ARRIS Technical Support at 1-877-466-8646 for assistance.</p>
Cannot Access the Internet	<p>Check that all cable and power connections on your cable modem and computer are properly connected.</p>

Modem Problem	Possible Solution
	<p>Check that the Power and Online LED icons on the front panel are lit up solid.</p> <p>Contact your service provider for assistance.</p>

Front panel LED icons and error conditions

The SB8200 front panel LED icons provide status information for the following error conditions:

Front panel LED icons and error conditions

LED Icon	Status	If, During Startup:	If, During Normal Operation
 POWER	OFF	SB8200 is not properly plugged into the electrical outlet	SB8200 is unplugged
 RECEIVE	FLASHING	Downstream receive channel cannot be acquired	Downstream channel is lost
 SEND	FLASHING	Upstream send channel cannot be acquired	Upstream channel is lost
 ONLINE	FLASHING	IP registration is unsuccessful	IP registration is lost

Warranty Information

CommScope, Inc. ("ARRIS")

Retail Purchasers

If you purchased this Product directly from ARRIS or from an authorized ARRIS retail reseller, ARRIS warrants to you, the original end user customer, that (A) the Product, excluding Software, will be free from defects in materials and workmanship under normal use, and (B) with respect to Software, (i) the media on which the Software is provided will be free from defects in material and workmanship under normal use, and (ii) the Software will perform substantially as described in its documentation. This Limited Warranty to you, the original end user customer, continues (A) for Software and the media upon which it is provided, for a period of ninety (90) days from the date of purchase from ARRIS or an authorized ARRIS reseller, and (B) for the Product (excluding Software), for a period of two (2) years from the date of purchase from ARRIS or from an authorized ARRIS reseller. To take advantage of this Limited Warranty or to obtain technical support, you must call the ARRIS toll-free phone number: **1-877-466-8646**. ARRIS' sole and exclusive obligation under this Limited Warranty for retail sales shall be to repair or replace any Product or Software that does not meet this Limited Warranty. All warranty claims must be made within the applicable Warranty Period.

Cable Operator or Service Provider Arrangements

If you did not purchase this Product directly from ARRIS or from a ARRIS authorized retail reseller, ARRIS does not warrant this Product to you, the end-user. A limited warranty for this Product (including Software) may have been provided to your cable operator or Internet Service Provider ("Service Provider") from whom you obtained the Product. Please contact your Service Provider if you experience problems with this Product.

General Information

The warranties described in this Section shall not apply: (i) to any Product subjected to accident, misuse, neglect, alteration, Acts of God, improper handling, improper transport, improper storage, improper use or application, improper installation, improper testing, or unauthorized repair; or (ii) to cosmetic problems or defects which result from normal wear and tear under ordinary use, and do not affect the performance or use of the Product. ARRIS' warranties apply only to a Product that is manufactured by ARRIS and identified by ARRIS owned trademark, trade name or product identification logos affixed to the Product. ARRIS does not warrant to you, the end user, or to anyone else that the Software will perform error free or without bugs.

ARRIS IS NOT RESPONSIBLE FOR, AND PROVIDES "AS IS" ANY SOFTWARE SUPPLIED BY 3RD PARTIES. EXCEPT AS EXPRESSLY STATED IN THIS SECTION ("WARRANTY INFORMATION"), THERE ARE NO WARRANTIES OF ANY KIND RELATING TO THE PRODUCT, EXPRESS, IMPLIED OR STATUTORY, INCLUDING BUT NOT LIMITED TO IMPLIED WARRANTIES OF MERCHANTABILITY, FITNESS FOR A PARTICULAR PURPOSE, OR THE WARRANTY AGAINST

INFRINGEMENT PROVIDED IN THE UNIFORM COMMERCIAL CODE. Some states do not allow for the exclusion of implied warranties, so the above exclusion may not apply to you.

What additional provisions should I be aware of? Because it is impossible for ARRIS to know the purposes for which you acquired this Product or the uses to which you will put this Product, you assume full responsibility for the selection of the Product for its installation and use. While every reasonable effort has been made to ensure that you will receive a Product that you can use and enjoy, ARRIS does not warrant that the functions of the Product will meet your requirements or that the operation of the Product will be uninterrupted or error-free.

ARRIS IS NOT RESPONSIBLE FOR PROBLEMS OR DAMAGE CAUSED BY THE INTERACTION OF THE PRODUCT WITH ANY OTHER SOFTWARE OR HARDWARE. ALL WARRANTIES ARE VOID IF THE PRODUCT IS OPENED, ALTERED, AND/OR DAMAGED.

THESE ARE YOUR SOLE AND EXCLUSIVE REMEDIES for any and all claims that you may have arising out of or in connection with this Product, whether made or suffered by you or another person and whether based in contract or tort.

IN NO EVENT SHALL ARRIS BE LIABLE TO YOU OR ANY OTHER PARTY FOR ANY DIRECT, INDIRECT, GENERAL, SPECIAL, INCIDENTAL, CONSEQUENTIAL, EXEMPLARY OR OTHER DAMAGES ARISING OUT OF THE USE OR INABILITY TO USE THE PRODUCT (INCLUDING, WITHOUT LIMITATION, DAMAGES FOR LOSS OF BUSINESS PROFITS, BUSINESS INTERRUPTION, LOSS OF INFORMATION OR ANY OTHER PECUNIARY LOSS), OR FROM ANY BREACH OF WARRANTY, EVEN IF ARRIS HAS BEEN ADVISED OF THE POSSIBILITY OF SUCH DAMAGES. IN NO CASE SHALL ARRIS' LIABILITY EXCEED THE AMOUNT YOU PAID FOR THE PRODUCT.

These matters are governed by the laws of the Commonwealth of Pennsylvania, without regard to conflict of laws principles and excluding the provisions of the United Nations Convention on Contracts for the International Sale of Goods.

Retail Purchasers Only

If you purchased this Product directly from ARRIS or from an ARRIS authorized retail reseller, please call the ARRIS toll-free phone number, **1-877-466-8646**, for warranty service or technical support.

Cable Operator or Service Provider Arrangements

If you did not purchase this Product directly from ARRIS or from an ARRIS authorized retail reseller, please contact your Service Provider for technical support.

Corporate Headquarters
CommScope • Hickory • North Carolina • 28602 • USA
T: 1-828-324-2200
www.commscope.com