

CHEFMAN®

TurboFry® Touch

DUAL AIR FRYER

USER GUIDE

- Safety Instructions
- Features
- Control Panel
- Operating Instructions
- Air Frying Chart
- Air Fryer Cooking Tips
- Troubleshooting
- Cleaning and Maintenance
- Notes
- Terms and Conditions
- Warranty Registration

RJ38-SQPF-45TDB

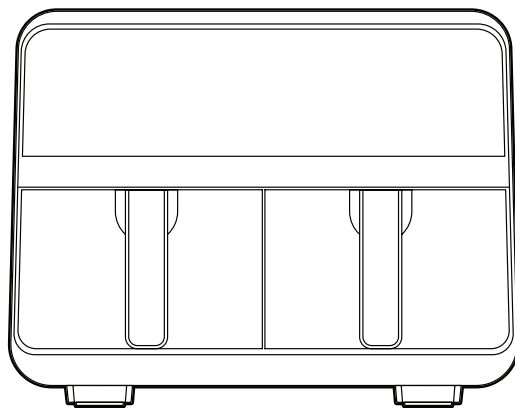

COOKING FORWARD™

Welcome!

Whether this is your first Chefman® appliance or you're already part of our family, we're happy to be cooking with you! With your new TurboFry® Touch Dual Air Fryer, you can air fry foods to crisp perfection with little to no oil for healthier eating. With two 4.5-quart baskets, you can make a main dish and sides, or heat up two crispy snacks for a game-night spread. The Sync Finish feature allows foods with different cook times to finish at the same time.

We know you're excited to get cooking, but please take a few minutes to read our directions, safety instructions, and warranty information.

From our kitchen to yours,

The Chefman® Team



READ ALL INSTRUCTIONS BEFORE USE
For your safety and continued enjoyment of this product, always read the instruction manual before using.

CONTENTS

- 1** Safety Instructions
- 5** Features
- 6** Control Panel
- 7** Operating Instructions
- 13** Air Frying Chart
- 16** Air Fryer Cooking Tips
- 17** Troubleshooting
- 18** Cleaning and Maintenance
- 19** Notes
- 21** Terms and Conditions
- 23** Warranty Registration

SAFETY INSTRUCTIONS

IMPORTANT SAFEGUARDS

WARNING: When using electrical appliances, basic safety precautions should always be followed, including:

1. Read all instructions.
2. Do not touch hot surfaces. Use handles or knobs.
3. To protect against electrical shock, do not immerse the cord or plug in water or other liquids.
4. Close supervision is necessary when any appliance is used by or near children.
5. Unplug from the outlet when not in use and before cleaning. Allow to cool before putting on or taking off parts.
6. Do not operate any appliance with a damaged cord or plug, or after the appliance malfunctions or has been damaged in any manner. Contact Chefman® Customer Support.
7. The use of accessory attachments not recommended by the appliance manufacturer may cause injuries.
8. Do not use outdoors.
9. Do not let the cord hang over the edge of a table or counter or touch hot surfaces.
10. Do not place on or near a hot gas or electric burner, or in a heated oven.
11. Extreme caution must be used when moving an appliance containing hot oil or other hot liquids.
12. To disconnect, turn any control to “off,” then remove the plug from the wall outlet.
13. Do not use the appliance for other than intended use.
14. Place the unit on a flat, sturdy, heat-resistant surface. Do not place the unit near or on any type of heat source, such as a gas or electric burner, stove, or oven, even if not on. Do not use near an open flame or flammable materials.

SAFETY INSTRUCTIONS

IMPORTANT SAFEGUARDS

15. The unit will emit some heat. Allow sufficient space around the unit when in use, and do not place near other items or appliances.
16. Check that your home power supply corresponds with the intended voltage of the TurboFry® Touch Dual Air Fryer.
17. Never wrap the cord tightly around the appliance during use or storage; this may cause the wire to fray and break.
18. This product is not a deep fryer. It is NOT meant to be filled with oil. Never fill any parts of the air fryer with oil. If you choose to use oil, toss food with oil in a separate bowl, and then transfer food to the removable racks or baskets.
19. Do not leave uncooked ingredients in the air fryer for more than a short period of time before cooking; raw meat, poultry, fish, fruits, and vegetables can spoil.
20. Do not move the air fryer while it is full of food.
21. Do not move the unit during use. During initial use, you may notice some smoke and/or a slight odor. This is normal and should quickly dissipate. It should not happen after the appliance has been used a few more times.
22. Do not leave the air fryer unattended during use.
23. Some areas do get HOT during use, and the touch screen may get warm. Do not touch the heating elements. Do not place hands or other body parts near the air vents while the air fryer is in use; burns may result. Take caution when handling the hot air fryer rack and all removable parts.
24. Use protective mitts and/or tongs to remove hot food from the air fryer.
25. Store the air fryer in a cool, dry place.

SAVE THESE INSTRUCTIONS

SAFETY INSTRUCTIONS

IMPORTANT SAFEGUARDS

WARNING: This appliance has a polarized plug (one blade is wider than the other). This plug is intended to fit into a polarized outlet only one way. If the plug does not fit fully into the outlet, reverse the plug. If it still does not fit, contact a qualified electrician. Do not attempt to modify the plug in any way or force it into the outlet. This could result in injury or electrical shock.

SHORT-CORD INSTRUCTIONS

A short power-supply cord is provided to reduce the hazards of entanglement or tripping over a longer cord. Longer detachable power-supply cords or extension cords are available and may be used if care is exercised in their use. If a longer detachable power-supply extension cord is used:

1. The marked electrical rating of the extension cord should be at least as great as the electrical rating of the appliance.
2. The cord should be arranged so that it will not drape over a countertop or tabletop, where it can be pulled on by children or tripped over.

SAFETY INSTRUCTIONS

IMPORTANT SAFEGUARDS

POWER-CORD SAFETY TIPS

1. Never pull or yank on the cord or the appliance.
2. To insert the plug, grasp it firmly and guide it into the outlet.
3. To disconnect the appliance, grasp the plug and remove it from the outlet.
4. Before each use, inspect the power cord for cuts and/or abrasion marks. If any are found, please contact Chefman® Customer Support for assistance.
5. Never wrap the cord tightly around the appliance, as this could place undue stress on the cord where it enters the appliance and cause it to fray and break.

DO NOT OPERATE THE APPLIANCE IF THE POWER CORD SHOWS ANY DAMAGE OR IF THE APPLIANCE WORKS INTERMITTENTLY OR STOPS WORKING ENTIRELY.

*California Proposition 65:
(Applicable for California Residents only)*



WARNING:
Cancer and Reproductive Harm -
www.P65Warnings.ca.gov.



Do not place the appliance on a stovetop or any other heatable surface, even if stovetop is not on. Doing so is a fire hazard.

FEATURES

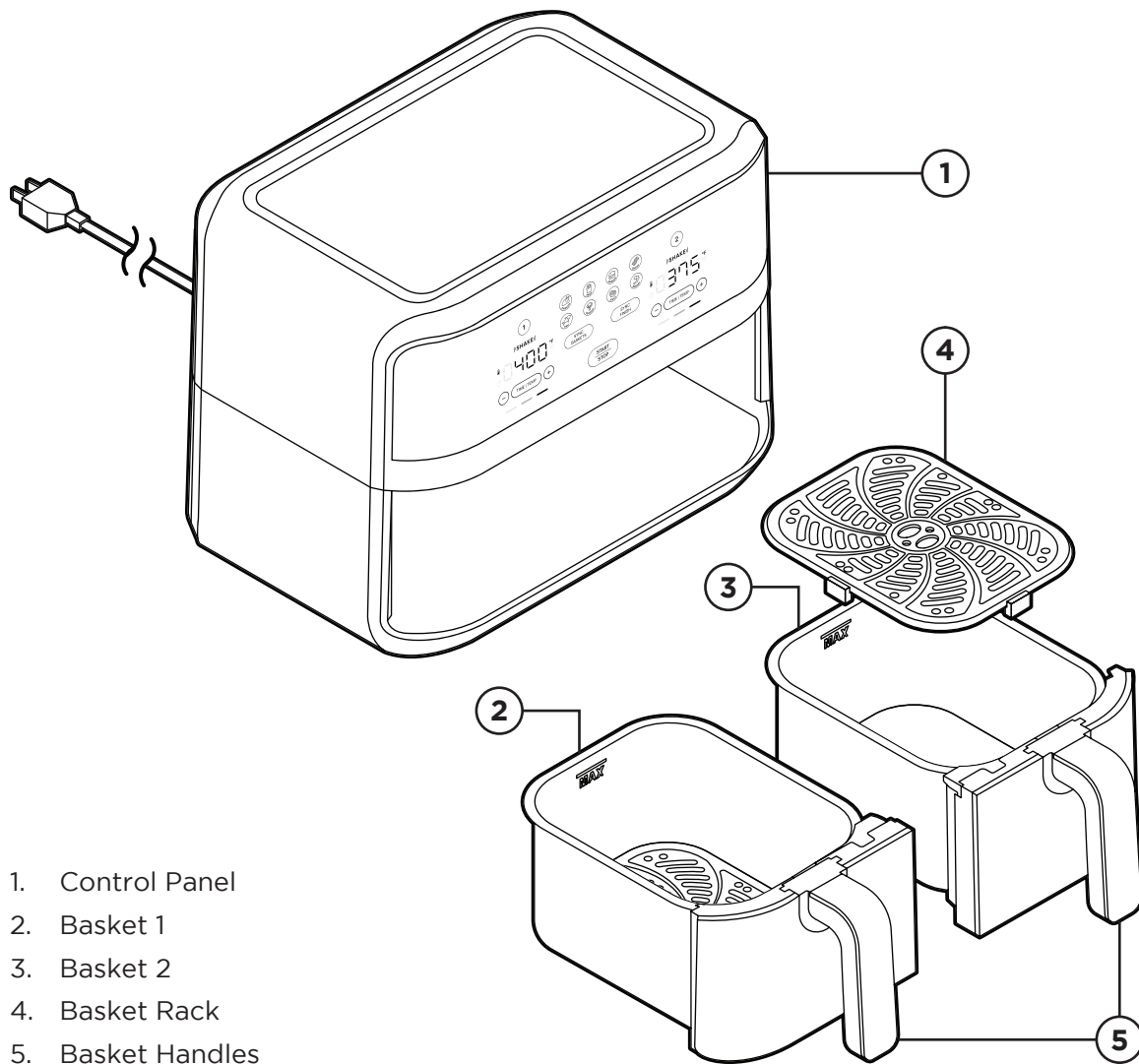

1. Control Panel
2. Basket 1
3. Basket 2
4. Basket Rack
5. Basket Handles

CONTROL PANEL

Shake Lights

Illuminate midway through cooking as a reminder to shake basket.

Start/Stop Button

Starts and stops the cooking cycle for the basket number that's illuminated in blue, or for both baskets if the Sync Baskets button is illuminated.

Cooking Preset Buttons

Automatically set time and temperature for popular foods.

Time/Temp Displays

Toggle between time and temperature for each basket.

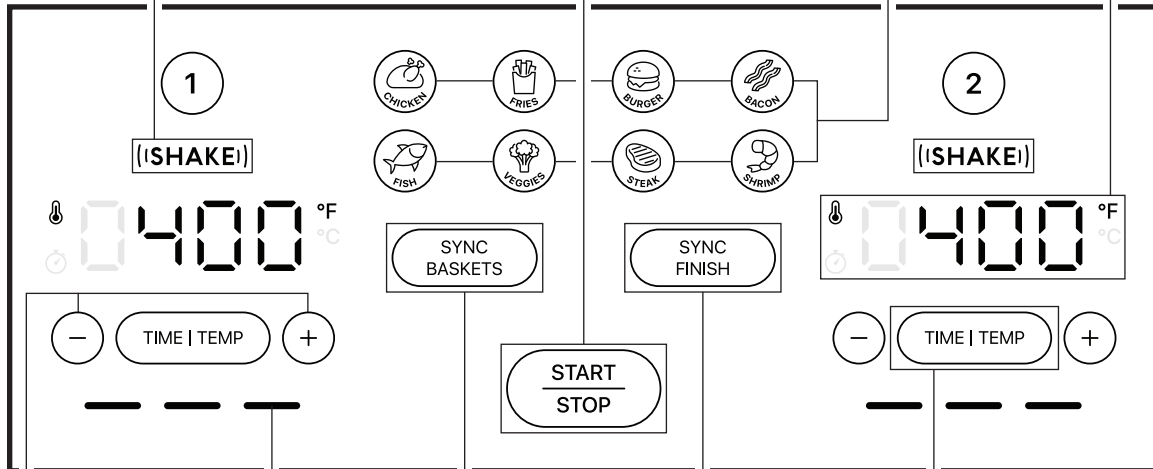

+ and - buttons

Use to increase or decrease time and temperature. Press and hold both on left side to toggle between °F and °C. Press on right side to turn sound off and on.

Running Lights

Illuminate when basket is actively cooking.

Sync Baskets Button

Programs both baskets to cook at the same time and temperature.

Sync Finish Button

Programs baskets with different cooking times and/or temperatures to finish at the same time.

Time/Temp Buttons

Select time or temperature to set for each basket. Time adjusts by 1 minute and temperature by 5°.

OPERATING INSTRUCTIONS

PRESET FUNCTION CHART

FOOD	Default Time	Default Temp (°F)
Fries	20 minutes	400
Chicken	30 minutes	375
Fish	10 minutes	350
Bacon	10 minutes	400
Burgers	10 minutes	350
Steak	10 minutes	350
Vegetables	15 minutes	350
Shrimp	10 minutes	400

BEFORE FIRST USE

For best results, follow these steps before using your air fryer for the first time.

1. Remove all packaging materials, such as plastic bags and foam inserts.
2. Check to ensure that all parts and accessories are accounted for.
3. Read and remove any stickers on the unit except for the rating label on the bottom, which should remain on the unit.
4. Wipe down the interior and exterior with a damp cloth.
5. Wash the baskets and racks with warm, soapy water. Dry thoroughly.

OPERATING INSTRUCTIONS

PREPARE TO COOK

The air fryer's high-speed fans cook your favorite foods quickly. The rubber feet on the racks elevate the racks to allow air to circulate around foods for even cooking and crisping. The racks also allow excess fat drip down and away from foods for healthier eating.

CAUTION: Never fill the baskets with oil. Unlike deep fryers, air fryers require little to no oil to produce a crisp texture. If you choose to use oil, toss foods with just a little in a separate bowl before cooking in the air fryer.

1. Prepare the food(s) you plan to air fry. (See the Air Frying Chart starting on p. 13 for how to prepare and air fry some favorite foods.)
2. Place the air fryer on a hard, flat surface and plug it in. The control panel will illuminate in white, and the ① button will illuminate in blue, indicating that basket 1 is ready to have its cooking time and temperature set.
3. Lower the racks into the baskets, or just one rack if cooking in just one basket. Press

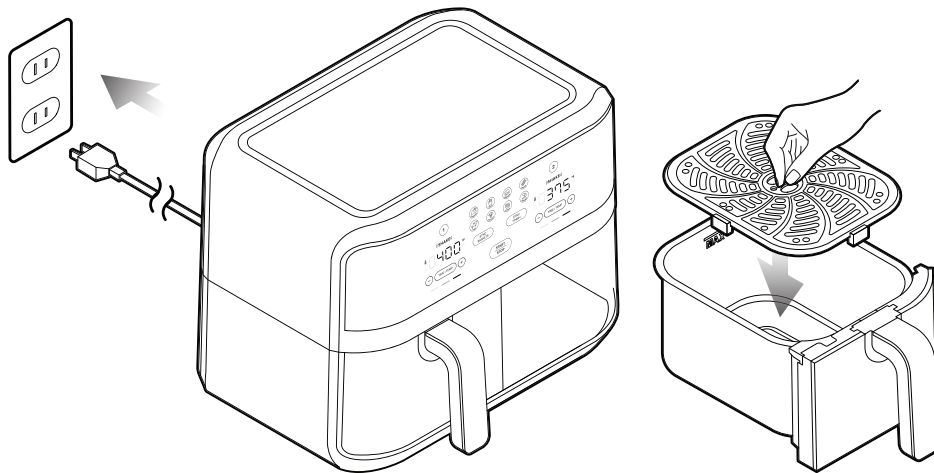

OPERATING INSTRUCTIONS

down on the racks to ensure they are secure and level. There should be a small amount of space between the rack(s) and the bottom of the basket(s). (For easiest handling of the basket rack, pinch the center grip bar with your thumb and index finger.)

CAUTION: Never spray the baskets or racks with cooking oil from an aerosol spray can, which includes harsh components that can cause chipping of the nonstick coating. However, you can oil the racks or spray them with oil from a non-aerosol mister.

4. Put food on the rack(s). To allow for good air circulation, do not fill the basket(s) past the Max line.
5. Slide the basket(s) into the air fryer. (If cooking in just one basket, the other does not need to be in place.) **NOTE:** On first use, the unit may emit a slight odor, which is normal and will dissipate with use.

HOW TO COOK IN ONE BASKET

Though the beauty of this air fryer is its double-basket capacity and sync functions, you can easily cook in just one basket, which is the default mode. (The other basket can be removed or left in the unit on standby.)

1. Prepare for air fryer cooking as directed starting on p. 8.
2. Set the time and temperature for basket 1: To set the temperature, press the Time/Temp button until the temperature displays, then press the plus or minus sign. To set the time, press the Time/Temp button until the time displays, and then press the plus or minus sign. If cooking with a preset function, choose the icon that best represents the food you're cooking and press the icon. This will set the pre-programmed time and temperature (see Chart on p. 7 for details).
3. Press Start.
4. During cooking, the Shake light on the control panel will turn on, and the air fryer will beep as a reminder to shake (or flip) food, as necessary. (See Chart on p. 13 for more

OPERATING INSTRUCTIONS

details on timing.) The light will turn off immediately when the basket is removed and will go off automatically after about 10 seconds if the basket is not pulled out. (If your food does not need to be shaken, flipped, or turned, simply ignore the warning.)

5. When the timer is done, the air fryer will turn off automatically. Remove the basket from the unit. Check food for doneness, then carefully transfer the food to plates or a platter and serve.

NOTE: While the unit is cooking on one side, you can begin cooking in the other basket at any time. (The Sync Baskets and Sync Finish functions will not be available, however.) Simply press the other basket's button on the display and set the time and temperature for that side. Do NOT press Start. The running lights for that basket will come on to show that it's cooking.

HOW TO COOK USING SYNC BASKETS

The Sync Baskets button is a shortcut for setting both baskets to cook simultaneously with the same time and temperature.

1. Prepare to cook as directed starting on p. 8.
2. Set the time and temperature for basket 1: To set the temperature, press the Time/Temp button until the temperature displays, and then press the plus or minus sign. To set the time, press the Time/Temp button until the time displays, and then press the plus or minus sign. If cooking with preset cooking parameters, choose the icon that best represents the food you're cooking and press the icon. This will set the preprogrammed time and temperature. (See Chart on p. 7 for details.)
3. Press the Sync Baskets button. The air fryer will automatically apply the time and temperature from basket 1 to basket 2.

OPERATING INSTRUCTIONS

4. Press Start.
5. If one basket's time or temperature is adjusted during cooking, the other basket will automatically adjust to match.
6. During cooking, the Shake lights will turn on for both baskets, and the air fryer will beep as a reminder to shake (or flip) food, as necessary. (See Chart on p. 13 for more details on timing.) When one basket is removed, both sides will pause cooking until the basket is returned. The Shake light will turn off immediately when the corresponding basket is removed and will go off automatically after about 10 seconds if the basket is not pulled out. (If your food does not need to be shaken or flipped, simply ignore the alert.)
7. When the timer is done, the air fryer will turn off automatically. Remove the baskets from the unit. Check food on both sides for doneness, then carefully transfer food to plates or a platter and serve.

HOW TO COOK USING SYNC FINISH

By pressing the Sync Finish button, you can program two foods with different cooking times and/or temperatures to finish cooking at the same time. The function delays the start of the basket with the shorter cook time so that both baskets finish their cook cycles simultaneously.

1. Prepare to cook as directed starting on p. 8.
2. With both baskets in place, set the time and temperature for basket 1: To set the temperature, press the Time/Temp button until the temperature displays, and then press the plus or minus sign. To set the time, press the Time/Temp button until the time displays, and then press the plus or minus sign. If cooking with a preset function, choose the icon that best represents the food you're cooking and press the icon. This will set the preprogrammed time and temperature. (See Chart on p. 7 for details.)

OPERATING INSTRUCTIONS

3. Press the ② button, then set the time and temperature (or a preset function) for basket 2 the same way you did for basket 1.
4. Press the Sync Finish button, then press Start. The air fryer will begin cooking on the side with the longer cooking time and will delay the start of cooking on the other side until the appropriate time so that they finish together. On the side that is cooking, you will see running lights (three dashes under the Time/Temp button). Running lights will not light up on a basket until it begins cooking.
5. During cooking, the Shake light will turn on for both baskets (not necessarily simultaneously), and the air fryer will beep as a reminder to shake (or flip) food, as necessary. (See Chart on p. 13 for more details on timing.) When one basket is removed, both sides will pause cooking until the basket is returned. The Shake light will turn off immediately when the corresponding basket is removed and will go off automatically after about 10 seconds if the basket is not pulled out. (If your food does not need to be shaken or flipped, simply ignore the alert.)
6. If either timer is adjusted while one of the baskets is still waiting to cook and the timer with the shorter time is not increased above the longer time, then the finish will remain synced. If either timer is adjusted while both sides are actively cooking, then the sync will break, and the Sync Finish LED will turn off.
7. When the timer is done, the air fryer will turn off automatically. Remove the baskets from the unit. Check food in both baskets for doneness, then carefully transfer food to plates or a platter and serve.

AIR FRYING CHART

The times below do not include a preheat. Quantities indicate the amount the air fryer can accommodate with ample room for air flow.

Ingredient	Amount	Prep	Oil	Time (min)	Temp (°F)	Shake/Flip
Vegetables						
Asparagus	6 oz (about 9 fat spears)	Tough ends trimmed	Toss with a little oil	6-8	400	Flip once
Broccoli	6 oz (½ head)	Cut into florets	Toss with a little oil	6-8	375	Shake once
Brussels sprouts	6 oz	Halved, stem removed	Toss with a little oil	14-15	380	Shake once
Carrots	8 oz	Peeled, cut into 1-inch pieces	Toss with a little oil	10-12	400	Shake once
Cauliflower	13 oz	Cut into florets	Toss with a little oil	12-13	400	Shake once
Corn on the cob	2 ears, whole	Husks removed	Brush with a little oil or butter	15	400	Flip once
Green beans	7 oz	Trimmed	Toss with a little oil	6-8	400	Shake once
Potatoes (red or yellow)	11 oz	Cut into 1-inch chunks	Toss with a little oil	14-15	400	Shake once
Potatoes (baking)	3 whole, 8-9 oz each	Poke all over with a fork	Rub with a little oil	33-36	400	No
Sweet potatoes	12 oz	Peel, cut into 1-inch chunks	Toss with a little oil	14-15	400	Shake once
Zucchini	8 oz	Slice into ½-inch rounds	Toss with a little oil	18-20	400	Shake every 4 minutes

AIR FRYING CHART

Ingredient	Amount	Prep	Oil	Time (min)	Temp (°F)	Shake/Flip
Seafood						
Crab cakes	2 cakes (4 oz each)		Brush lightly or spray with oil	11-14	375	No
Salmon	2 6-oz fillets (long and skinny work best)		Brush skin side lightly with oil	9-11 (for medium)	400	Gently flip once
Shrimp (large, peeled)	11 oz		Toss with a little oil	4-5	400	Shake once
Thin fish fillet (e.g., flounder)	1 5-oz fillet		Brush lightly with oil	5-6	350	No
Frozen Foods						
Apple turnovers	3		None	17-19	350	Flip 2 minutes before end
Chicken tenders	5		None	11-12	375	Shake once
Chicken nuggets	12		None	9-10	400	Gently flip once
Fish sticks	10 pieces		None	7-8	400	Gently flip once
French fries (thin)	12 oz		Toss with a little oil	16-18	400	Shake every 5 minutes
French fries (thick)	12 oz		Toss with a little oil	19-21	400	Shake every 5 minutes
Mozzarella sticks	8 pieces		None	6-7	380	Flip once
Tater tots	12 oz		None	16-17	400	Shake every 5 minutes

AIR FRYING CHART

Ingredient	Amount	Prep	Oil	Time (min)	Temp (°F)	Shake/Flip
Meat						
Bacon	3 slices		None	11-12	400	No, but check to ensure bacon isn't touching
Chicken breast (boneless, skinless)	2 (6-8 oz each)	Trim excess fat and season as desired	Brush lightly with oil	18-20	375	Flip once
Chicken wings (flats and drumettes)	9 pieces	Season as desired	Toss with a little oil	24-27	375	Shake once
Hamburgers/ Cheeseburgers*	2 4- to 5-oz patties (80% lean)		None	10* (for medium)	350	Flip once
Pork chops (bone-in)	1 12-oz chop	Season as desired	None	14-17	400	Flip once
Steak	1 strip steak (12 oz, 3/4 inch thick)	Season as desired	None	7-8 (med rare), 10-11 (for medium)	350-400	Flip once

*For medium-rare, cook at 380°F for 8 to 9 minutes. For cheeseburgers, top patties with cheese once cooking has completed, then slide the basket closed to let the cheese melt for about 30 seconds.

NOTE: The times and temperatures offered in these charts are suggestions and may vary. Please follow current food-safety guidelines when determining doneness.

AIR FRYER COOKING TIPS

For a crisp exterior, oil foods lightly. Some foods, especially if fresh, benefit from being tossed with a little oil in a separate bowl before frying. However, high-fat foods, like a well-marbled steak, or prepared foods usually require no additional oil.

Avoid wet batters. Loose batters, such as those used for deep frying, do not work in air fryers, as the batter simply slides off. Adapt such recipes to give foods a thicker coating, preferably including breadcrumbs to help the coating adhere.

Use medium-high to high heat for most cooking. Most foods will air fry best between 325°F and 400°F. For gentler cooking and reheating, use a lower temperature to avoid overcooking.

Don't overcrowd the baskets. Too much food, especially if tightly packed, can inhibit browning and crisping. A better bet: Fry food in batches.

Shake the baskets for even cooking. A good shake during the cooking cycle is especially beneficial for smaller items like french fries, onion rings, and chicken wings. For larger or more fragile foods, consider gently tossing or flipping for even results.

Check foods early. Check foods on the earlier side of cooking time; you can always slide the basket back in to continue cooking.

Follow food-safety guidelines for doneness. Because air fryer temperatures and food sizes can vary, do not rely only on recipe timing when cooking food. Check foods for doneness against current safety guidelines before serving.

Preheat the air fryer, if you like. While not necessary, preheating the unit can cook foods faster and promote crisp results. **CAUTION:** Be careful when adding food after preheating as the interior of the fryer will be hot.

TROUBLESHOOTING

Why is there white smoke coming from my unit?

White smoke can be a sign that there's too much fat in the fryer. Avoid cooking very fatty foods in the air fryer, and be sure the baskets, the racks, and the interior of the air fryer are clean before cooking.

Why has my food cooked unevenly?

Two culprits are likely: overcrowding and not shaking. Fill the air fryer baskets loosely with food to let air circulate, and shake, toss, or flip foods at least once during cooking for more even results.

Why isn't my food crisp?

Though you can air fry with no added oil, coating foods very lightly with oil (usually just $\frac{1}{2}$ teaspoon per batch for most recipes) helps guarantee crisp results. Preheating the fryer also helps.

Why is the unit displaying an error code?

If your air fryer displays E1 or E2 on its control panel, it means there is a loose wire contact or a short circuit, and the unit will not function. Should this occur, please contact Chefman® Customer Support for a replacement.

What do I do if a rack is missing a rubber foot?

Though they should be fairly secure, the feet on the rack are removable. Should one get lost, please contact Chefman® Customer Support for a replacement.

CLEANING AND MAINTENANCE

The nonstick coating on the baskets and racks makes the air fryer easy to clean following the steps below.

1. Unplug the unit and let cool completely before cleaning. (For faster cooling, take hot baskets out of the unit.)
2. To remove the cooled racks from the baskets, pinch the center grip bar on the rack, and pull the rack straight up and out of the basket. **WARNING:** Do not lift the rack out of the basket when hot, or injury can occur.
3. Wash the baskets and racks with warm, soapy water, rinse, and dry well with a towel for best results. Baskets and racks are also top-rack dishwasher-safe.
4. Wipe down the outside and the inside of the unit with a damp cloth as needed. Do not put the unit in the dishwasher or submerge in water or any other liquids.
5. Do not use abrasive cleansers on baskets, racks, or the interior or exterior of the appliance, or you could damage the finishes.

TERMS AND CONDITIONS

Limited Warranty

RJ Brands, LLC d/b/a Chefman® offers a limited 1-year Warranty (the “Warranty”) available on sales through authorized distributors and retailers only. Please note that this Warranty becomes valid from the date of initial retail purchase and that the Warranty is non-transferable and applies only to the original purchaser.

This Warranty is void without proof of purchase within the United States and Canada. Please be aware that this Warranty supersedes all other warranties and constitutes the entire agreement between the consumer and Chefman®. Any changes to the Terms and Conditions of this Warranty must be in writing, signed by a representative of Chefman®. No other party has the right or ability to alter or change the Terms and Conditions of this Warranty.

We may ask you to please submit, via email, photos and/or video of the issue you are experiencing. This is to help us better assess the matter and possibly offer a quick fix. Photos and/or video may also be required to determine warranty eligibility.

We encourage you to register your product. Registering can make the Warranty process easier and can keep you informed of any updates or recalls on your product. To register, follow the directions on the Chefman® Warranty Registration page in the Chefman® User Guide. Please retain your proof of purchase even after registering. In the event that you do not have proof of your purchase date, we may declare your Warranty void or we may, at our sole discretion, apply the date of manufacture as the purchase date for purposes of this Warranty.

TERMS AND CONDITIONS

Limited Warranty

WHAT THE WARRANTY COVERS

- **Manufacturer Defects** – Chefman® products are warranted against defects in material and workmanship, under normal household use, for a period of 1 year from the date of purchase when used in accordance with the directions listed in the Chefman® User Guide. If your product does not work as it should, please contact Customer Support at support@chefman.com so that we may assist you.

THIS WARRANTY DOES NOT COVER

- **Misuse** – Damage that occurs from neglectful or improper use of products, including, but not limited to, damage that occurs as a result of usage with incompatible voltage, regardless of whether the product was used with a converter or adapter. See Safety Instructions in the Chefman® User Guide for information on proper use of product;
- **Poor Maintenance** – General lack of proper care. We encourage you to take care of your Chefman® products so that you may continue to enjoy them. Please see Cleaning and Maintenance directions in the Chefman® User Guide for information on proper maintenance;
- **Commercial Use** – Damage that occurs from commercial use;
- **Normal Wear and Tear** – Damage or degradation expected to occur due to normal use over time;
- **Altered Products** – Damage that occurs from alterations or modifications by any entity other than Chefman® such as the removal of the rating label affixed to the product;
- **Catastrophic Events** – Damage that occurs from fire, floods, or natural disasters;
- **Loss of Interest** – Claims of loss of interest or enjoyment.

CHEFMAN® WARRANTY REGISTRATION

What do I need to register my product?

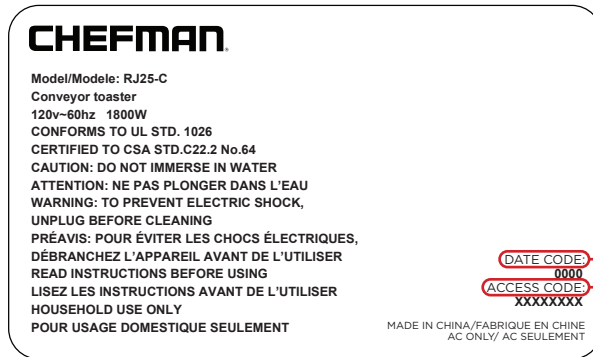

- Contact Information
- Model Number
- Proof of Purchase (online confirmation, receipt, gift receipt)
- Date Code
- Access Code

NOTE: Label depicted here is an example.

How do I register my product?

All you need to do is fill out a simple Chefman® registration form. You can easily access the form in one of the two ways listed below:

1. Visit chefman.com/register.
2. Scan the QR code to access site:

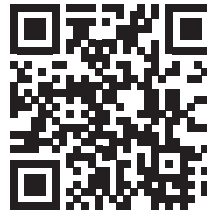

CHEFMAN® WARRANTY REGISTRATION

For product information, visit Chefman.com.

EXCEPT WHERE SUCH LIABILITY IS REQUIRED BY LAW, THIS WARRANTY DOES NOT COVER, AND CHEFMAN® SHALL NOT BE LIABLE FOR, INCIDENTAL, INDIRECT, SPECIAL, OR CONSEQUENTIAL DAMAGES, INCLUDING WITHOUT LIMITATION, DAMAGE TO, OR LOSS OF USE OF THE PRODUCT, OR LOST SALES OR PROFITS OR DELAY OR FAILURE TO PERFORM THIS WARRANTY OBLIGATION. THE REMEDIES PROVIDED HEREIN ARE THE EXCLUSIVE REMEDIES UNDER THIS WARRANTY, WHETHER BASED ON CONTRACT, TORT OR OTHERWISE.

Chefman® is a registered trademark of RJ BRANDS, LLC.
TurboFry® is a registered trademark of RJ BRANDS, LLC.
Cooking Forward™ is a trademark of RJ Brands, LLC.

CHEFMAN®

@mychefman



www.chefman.com

©CHEFMAN 2021