

# INSTALLATION INSTRUCTION

## Head Mount

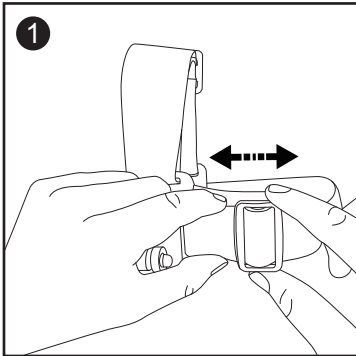

Adjust the head strap.

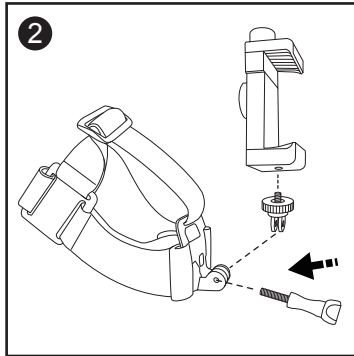

Mount the phone holder to the head strap.

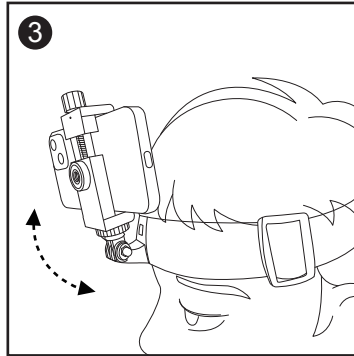

Adjust the angle of your phone as needed.

## Chest Mount

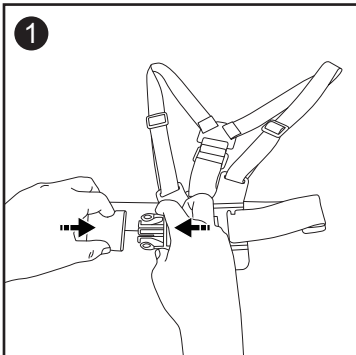

Release the buckle.

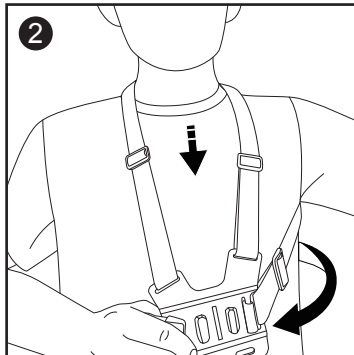

Wear our chest strap.

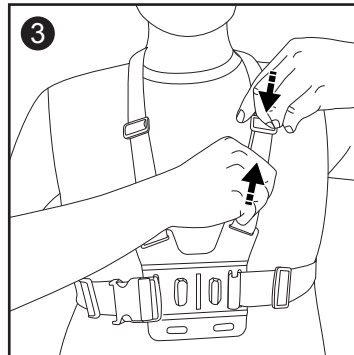

Adjust the chest belt of shoulder.

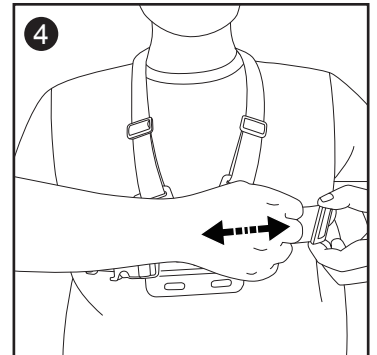

Adjust the chest belt of waist.

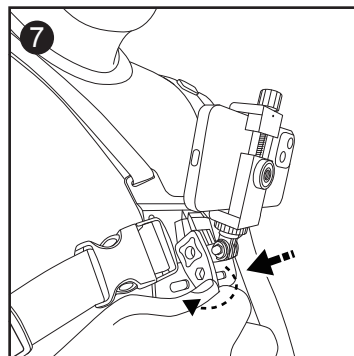
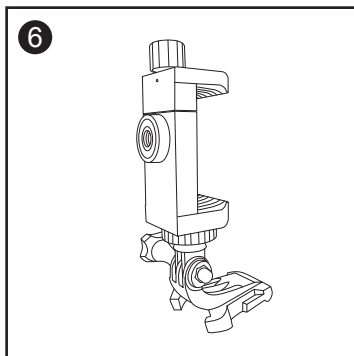
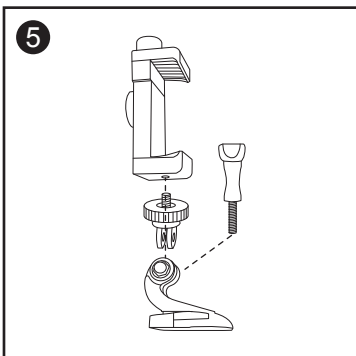

Tighten the screw with the wrench.

## Phone Lanyard

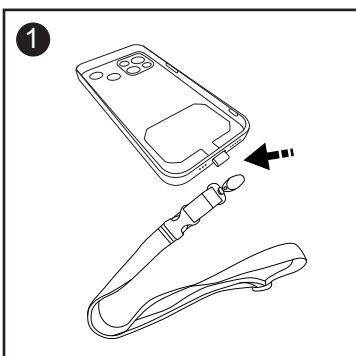

Insert the pad between your phone and phone case, attach the lanyard to your phone.

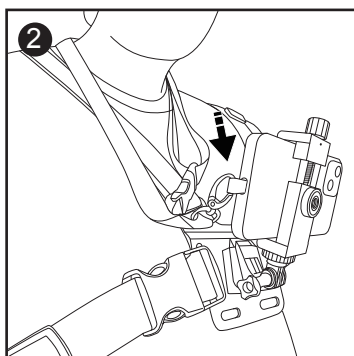

Mount your phone to our chest strap and adjust the angle as needed.

## Note

1. When it is used in mountain bike, motorcycle riding and other outdoor sports or violent sports, it is necessary to take the lanyard for protection.
2. Easy to use and Free your hands: You can always hang your smartphone around your neck, so you have hands and trouser pockets free, more space for you and more quickly accessible. For every situation, whether work, leisure, sport, shopping, party or festival.