

amazonbasics

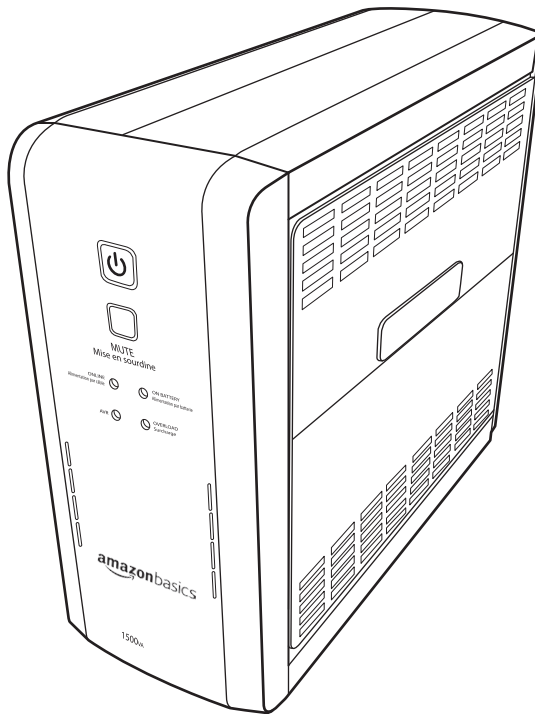

Line-Interactive UPS 1500VA 900 Watt, 10 Outlets
UPS de Línea Interactiva, 1500 VA, 900 Watts, 10 Tomas
Onduleur Line-Interactive 1 500 VA 900 Watts, 10 Sorties

B07RWMLKFM

K01-1198010-01

English

English	3
Español	17
Français	30

Español

Français

Welcome Guide • English

Contents:

Before getting started, ensure the package contains the following components:

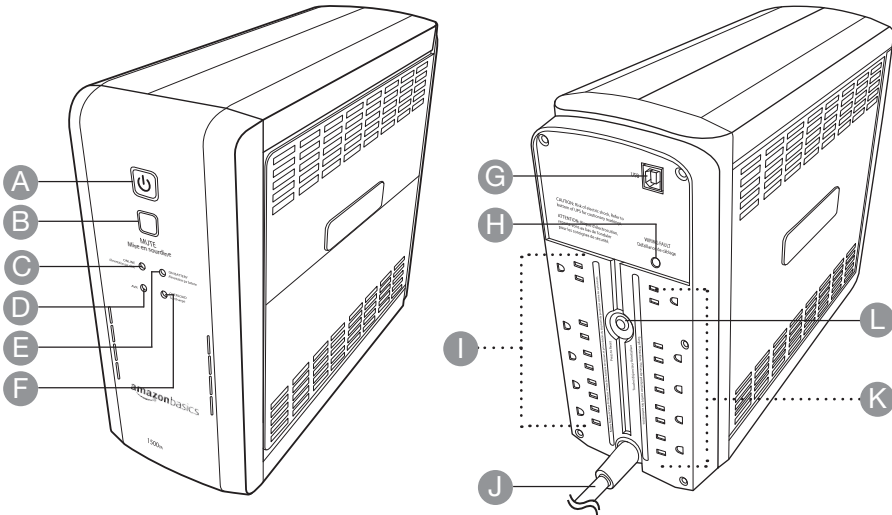

A Power button

B MUTE button

C ONLINE indicator

D AVR indicator

E ON BATTERY indicator

F OVERLOAD indicator

G USB type B socket

H WIRING FAULT indicator

I Battery backup & surge protection outlets

J Power cord with plug

K Surge protection outlets

L RESET button/circuit breaker

SAVE THESE INSTRUCTIONS



Read these instructions carefully and retain them for future use. If this product is passed to a third party, then these instructions must be included.

When using electrical appliances, basic safety precautions should always be followed to reduce the risk of fire, electric shock, and/or injury to persons including the following:

⚠ CAUTION Risk of Energy Hazard! 24 V, 9 Ampere-hour batteries. Before replacing batteries, remove conductive jewelry such as chains, wrist watches, and rings. High energy through conductive materials could cause severe burns.

⚠ CAUTION Risk of explosion! Do not dispose of batteries in fire. The batteries may explode.

⚠ CAUTION Risk of injury! Do not open or mutilate batteries. Released material is harmful to the skin and eyes. It may be toxic.

⚠ CAUTION Risk of electric shock! A battery can present a risk of electrical shock and high short-circuit current. The following precautions should be observed when working on batteries:

- Remove watches, rings, or other metal objects.
- Use tools with insulated handles.
- Wear rubber gloves and boots.
- Do not lay tools or metal parts on top of batteries.
- Disconnect charging source prior to connecting or disconnecting batteries terminals.

- Disconnect Device Requirement - for PLUGGABLE EQUIPMENT, the socket-outlet shall be installed near the equipment and shall be easily accessible.
- The maximum ambient operating temperature of the product is 104 °F (40 °C).
- Do not use surge protectors or extension cords with the product.
- Do not use for medical or life support equipment.
- Do not use with or near aquariums.
- Do not use the product on transportation means.
- Intended for installation in a temperature controlled, indoor area free of conductive contaminants.

⚠ WARNING Risk of fire, explosion, or burns! Do not disassemble, heat above 140 °F (60 °C), or incinerate the battery.

⚠ CAUTION Risk of electric shock! Do not remove the cover except to replace the battery. Turn off and unplug the product before replacing the batteries. There are no user serviceable parts inside except for the battery.

⚠ CAUTION Risk of fire! To reduce the risk of fire, connect only to a circuit provided with 20 amperes maximum branch circuit overcurrent protection in accordance with National Electric Code, ANSI/NFPA 70.

⚠ CAUTION Not for use in a computer room as defined in the Standard for the protection of information Technology Equipment, ANSI/NFPA 75.

Additional Battery Warnings

- Keep batteries out of the reach of children.
- If the battery leaks avoid contact with skin and eyes. Rinse affected areas immediately with plenty of clean water, then consult a doctor.
- If the product appears to be bulging or shows other undesirable phenomena (e.g. excess noise), stop using it immediately.
- Do not cover while in operation.
- Charge this product once every 3 months to avoid shortening its battery life.

Symbols



Provided battery contains Lead. Dispose of the battery according to local regulations.



Direct current.



Alternative current.

Before First Use

- Check for transport damages.
- Before connecting the product to the power supply, check that the power supply voltage and current rating corresponds with the power supply details shown on the product rating label.
- Choose a wall outlet that's in a branch circuit protected by a fuse or a circuit breaker and does not connect in parallel to appliances or equipment with a large power consumption.

⚠ DANGER **Risk of suffocation!** Keep any packaging materials away from children – these materials are a potential source of danger, e.g. suffocation.

NOTICE

To ensure the maximum batteries' capacity, it is recommended to charge the battery for at least 24 hours before first use.

NOTICE

The product is equipped with a delivery safety lock. The product needs to be connected to the power supply before the initial start-up.

Operation

Connecting an external equipment

⚠ CAUTION **Risk of damage!** Do not connect equipment with a combined power consumption of more than 1500 VA/900 W.

NOTICE It is suggested not to exceed 80% of the product's total capacity when connecting to the battery backup & surge protection outlets (I). Do not connect larger appliances, such as laser printers, paper shredders, heaters etc. to battery backup & surge protection outlets (I). The power requirement of such equipment might overload and potentially damage the product.

- Connect the external equipment to the product's outlets (I) or/and (K).
- Connect the power plug (J) to the appropriate wall outlet.

Switching on/off

Battery backup & surge protection outlets (I)

The outlets (I) provide battery backup and surge protection. In case of a power outage, battery power is automatically provided to these 5 outlets.

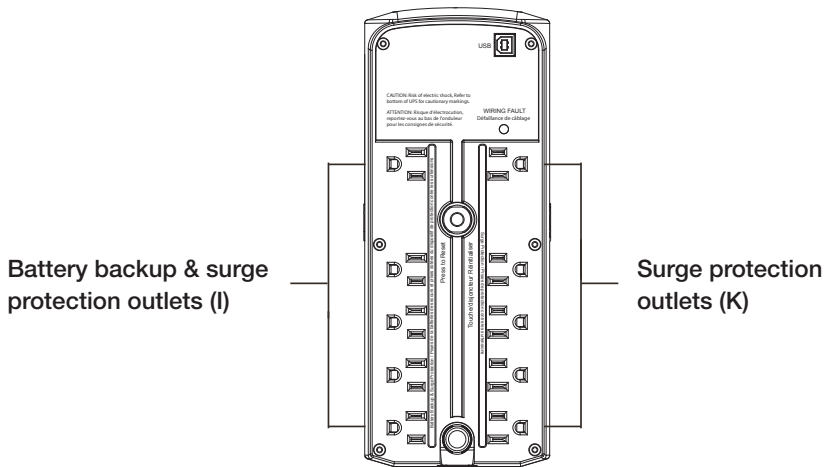

- Press the power button (A). The product beeps and the **ONLINE** indicator (C) lights up. The product supplies the power to the connected equipment.
- The product now supplies the power to the connected equipment.
- In case of a power outage, the **ON BATTERY** indicator (E) lights up and the product beeps twice in 7 seconds to indicate the battery backup mode operation.

NOTICE

If an overload is detected the product stops operation and the **OVERLOAD** indicator (F) lights up and the product beeps. Switch off the product and unplug at least one connected equipment so that the maximum capacity is not exceeded. Wait 10 seconds and press the **RESET** button (L). Then switch on the product again.

Surge protection outlets (K)

The outlets (K) provide only surge protection. Those outlets do not provide power during a power outage.

NOTICE

The surge protection (K) are constantly on, whenever the product is connected to the power supply.

NOTICE

The upper 2 outlets are positioned away from the other outlets in order to allow bulky AC power adapters to be connected.

Status

1. Power outage	The product operates in the battery backup mode.
2. Low battery	The battery capacity is low. The battery will be drained quickly during power outage.
3. Overload	Product rated capacity is exceeded. Switch off the product and unplug at least one connected equipment so that the maximum capacity is not exceeded. Wait 10 seconds and press the RESET button (L). Then switch on the product again.
4. Short fault	Switch off the product and unplug at least one connected equipment from the battery backup outlets. Then switch on the product again.
5. Charge fault	The battery charging voltage is too high or too low. Contact professional repair centre.

Indicators patterns

Status	Online (C)	On Battery (E)	AVR (D)	Overload (F)	Alarm
1.	OFF	Flashes while beeping	OFF	OFF	Beeps twice every 30 seconds
2.	OFF	Flashes while beeping	OFF	OFF	Beeps rapidly
3.	ON	OFF	OFF	ON	Constant alarm
	OFF	ON			
4.	ON	OFF	OFF	OFF	Constant alarm
	OFF	ON			
5.	ON	OFF	OFF	OFF	Beeps every 2 seconds
	OFF	ON			

Automatic voltage regulation

The product features **AVR** (Automatic Voltage Regulation) that allows to stabilize the inconsistent power input to the nominal level (110-120 V~) that is safe to the connected external equipment. Once the AVR protection is activated the **AVR** indicator (D) lights up.

Sensitivity Adjustment

In line mode, the AC input voltage can not be stable all the time. To prevent the connected equipment from damage caused by the unexpected voltage fluctuations, adjust the sensitivity of the product.

- Switch the product on in the line mode.
- Press the **MUTE** button (B) for 6 seconds. All indicators flash rapidly.
- The product indicates the current sensitivity setting:

Indicators	Sensitivity	Description
Red	Low	If the connected equipment can tolerate more power events (e.g. unstable power in a stormy weather), select Low Sensitivity and the product will go to Battery Mode less often.
Yellow, red	Medium (Default)	The product will go to Battery Mode if the power is unstable.
Green, yellow, red	High	If the connected equipment is more sensitive to power events, select High Sensitivity and the product will go to Battery Mode more often.

- To change the setting, press the **MUTE** button (B) repeatedly.
- To save the setting, press and hold the **MUTE** button (B) until the **ONLINE** indicator (C) lights up.

NOTICE

The product exits the sensitivity setup automatically if no button is pressed for 7 seconds.

Connecting to a computer

NOTICE

The PowerPanel® Personal software enables to view the connection and energy consumption status as well as configure the product. Use the type B to type A USB cable to connect the product to a computer.

Download and installation

- Visit www.amazon.com website.
- Search the B07RWMLKFM product number.
- Scroll down to “Technical Specification” section and download the PowerPanel® Personal software.
- Launch the software and follow the on-screen setup instructions.

Replacing the battery

⚠ CAUTION **Risk of Energy Hazard!** 24 V, maximum 9 Ampere-hour battery. Before replacing batteries, remove conductive jewelry such as chains, wrist watches, and rings. High energy through conductive materials could cause severe burns.

⚠ CAUTION **Risk of explosion!** Do not dispose of batteries in a fire. The batteries may explode.

⚠ CAUTION **Risk of injury!** Do not open or mutilate batteries. Released material is harmful to the skin and eyes. It may be toxic.

⚠ CAUTION **Risk of electric shock!** A battery can present a risk of electrical shock and high short circuit current. The following precautions should be observed when working on batteries:

- 1) Remove watches rings, or other metal objects.
- 2) Use tools with insulated handles.

NOTICE When replacing batteries, replace with the same number of the following battery: amazonbasics/ABRB1290X2.

- Switch off and unplug all the connected equipment.
- Switch off the product and disconnect it from the power supply.
- Place the product on its side, on a solid and stable surface.
- Loosen the battery compartment cover screws.

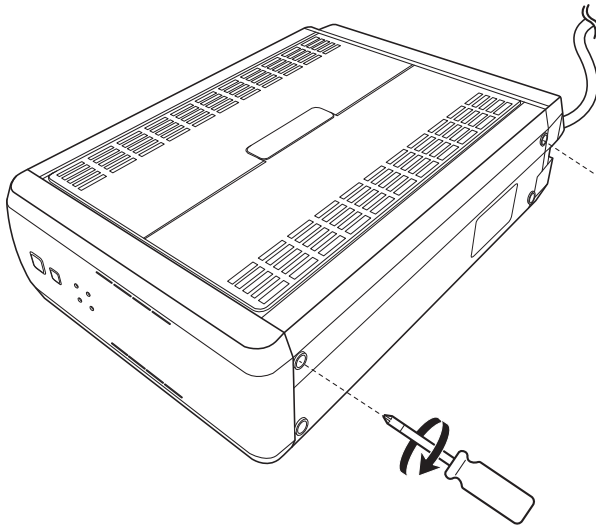

- Press on the locking latch and slide the battery compartment cover.

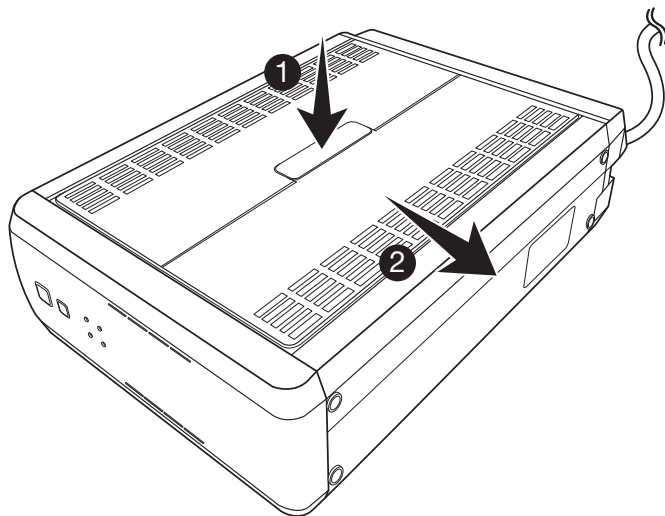

- Disconnect the wires from the battery II terminals and then take it out of the battery compartment.

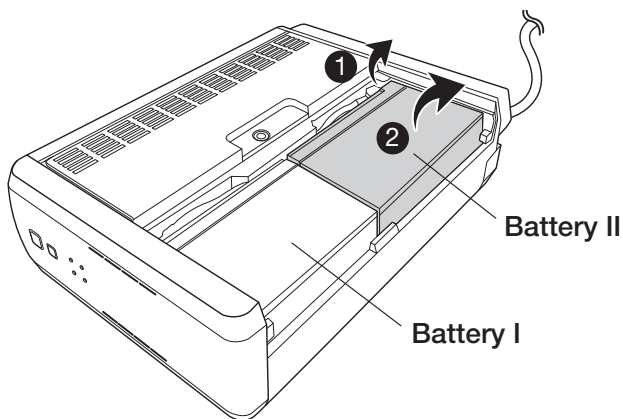

- Disconnect the wires from the battery I terminals.
- Slide the battery to the side and take it out of the battery compartment.

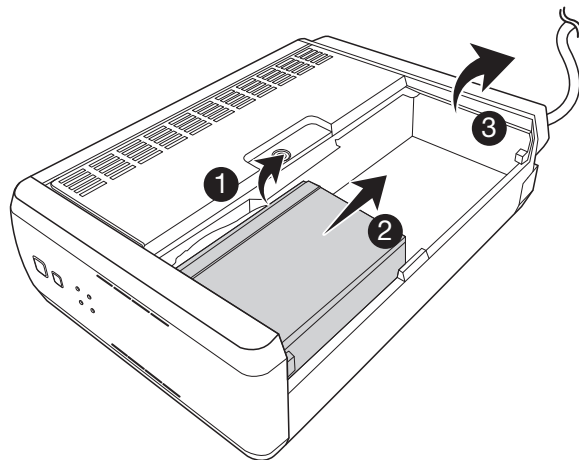

- Reverse the steps to install the new batteries into the battery compartment. Connect the wires as per table below.

Wire	Battery I	Battery II
Red		positive (+)
Yellow	positive (+)	negative (-)
Black	negative (-)	

- Close the battery compartment cover and secure it with the screws.

⚠ WARNING **Risk of explosion!** Always connect the (+) red connector and (-) black connector to the correct terminals (+) and (-). Then connect yellow connector to (+) terminal of battery I and other end to (-) terminal of battery II.

Cleaning and Maintenance

NOTICE Switch the product off and unplug it from the power supply before cleaning.

NOTICE During cleaning do not immerse the product in water or other liquids. Never hold the product under running water.

Cleaning

- To clean, wipe with a soft, slightly moist cloth.
- Never use corrosive detergents, wire brushes, abrasive scourers, metal or sharp utensils to clean the product.

Maintenance

- Replace the batteries after 3-6 years of use.

Storage

- Store the product covered in a cool, dry location, with the battery fully charged. Fully charge the battery every 3 months.

Transport

- Switch off and disconnect all the connected equipment. Disconnect the product from power supply and then disconnect all the internal batteries.
- Pack and secure the product properly to protect it from shocks and vibrations.

System Functional Block Diagram

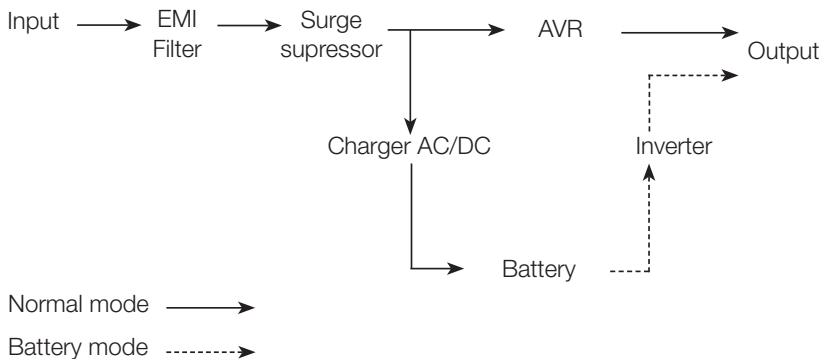

Troubleshooting

Problem	Possible cause	Solution
The circuit breaker has tripped.	Power supply overload.	Switch off the product and unplug at least one connected equipment so that the maximum capacity is not exceeded. Wait 10 seconds and press the RESET button (L). Switch on the product again.
The product does not perform expected runtime.	Battery is not fully charged.	Recharge the battery.
	Battery is worn out.	Replace the battery.
The product does not switch on.	The product is not connected to the socket-outlet.	The product must be connected to a 120 V, 60 Hz socket-outlet.
	The power button (A) is designed to prevent damage from rapidly turning it off and on.	Switch off the product. Wait 10 seconds and switch on the product again.
	Battery is worn out.	Replace the battery.
PowerPanel® Personal software is inactive (all icons are gray).	The USB / serial cable is not connected.	Connect the USB / serial cable to the product and an USB port of your computer.
	The USB / serial cable is connected to the wrong port.	Connect the USB / serial cable to another USB port of your computer.
	The product is not providing battery power.	Switch off the product. Wait 10 seconds and press the RESET button (L). Switch on the product again.

FCC – Supplier’s Declaration of Conformity

Unique Identifier	B07RWMLKFM - ABMT1500
Responsible Party	Amazon.com Services, Inc
U.S. Contact Information	410 Terry Ave N. Seattle, WA 98109, United States
Telephone Number	(206) 266-1000

FCC Compliance Statement

1. This device complies with Part 15 of the FCC rules. Operation is subject to the following two conditions:
 - (1) this device may not cause harmful interference, and
 - (2) this device must accept any interference received, including interference that may cause undesired operation.
2. Changes or modifications not expressly approved by the party responsible for compliance could void the user’s authority to operate the equipment.

FCC Interference Statement

This equipment has been tested and found to comply with the limits for a Class B digital device, pursuant to part 15 of the FCC Rules. These limits are designed to provide reasonable protection against harmful interference in a residential installation. This equipment generates, uses and can radiate radio frequency energy and, if not installed and used in accordance with the instructions, may cause harmful interference to radio communications. However, there is no guarantee that interference will not occur in a particular installation. If this equipment does cause harmful interference to radio or television reception, which can be determined by turning the equipment off and on, the user is encouraged to try to correct the interference by one or more of the following measures:

- Reorient or relocate the receiving antenna.
- Increase the separation between the equipment and receiver.
- Connect the equipment into an outlet on a circuit different from that to which the receiver is connected.
- Consult the dealer or an experienced radio/TV technician for help.

Canada IC Notice

- This Class B digital apparatus complies with Canadian CAN ICES-3(B) / NMB-3(B) standard.

Specifications

Model number:	ABMT1500
Input voltage/frequency:	120 V~, 57 Hz (\pm 0.5 Hz) - 63 Hz (\pm 0.5 Hz)
Battery backup mode output voltage/frequency:	120 V~ (\pm 5%), 60 Hz (\pm 1 %)
Power capacity:	1500 VA, 900 W
Maximum load for the surge protection outlets (K):	12 A
Battery type/voltage/capacity:	Maintenance-free sealed lead-acid battery 12 V --- , 9 AH Standby use: 13.5-13.8 V Cycle use: 14.4-15 V Initial current: less than 2.7 A
Battery backup mode wave form:	Simulated sine wave
Battery charging time:	24 Hours to 90% from full discharge
Estimated backup battery time:	Half Load (450 W) - 10 minutes Full Load (900 W) - 1.5 minutes
Operating temperature:	32 °F to 104 °F (0 °C to 40 °C)
Operating humidity:	10 – 95 % RH
Net weight:	24.1 lbs (11 kg)
Dimensions (W x H x D):	3.9 x 9.8 x 13.7" (10 x 24.8 x 34.7 cm)

Feedback and Help

Love it? Hate it? Let us know with a customer review. AmazonBasics is committed to delivering customer-driven products that live up to your high standards. We encourage you to write a review sharing your experiences with the product.



[amazon.com/review/review-your-purchases#](https://www.amazon.com/review/review-your-purchases#)



[amazon.com/gp/help/customer/contact-us](https://www.amazon.com/gp/help/customer/contact-us)

amazonbasics

amazon.com/AmazonBasics

MADE IN CHINA
HECHO EN CHINA
FABRIQUÉ EN CHINE

V8-01/20