

SEAUTO SEAL SE

EN

Instruction Manual



Bluetooth®



App Store



Google Play



WiFi

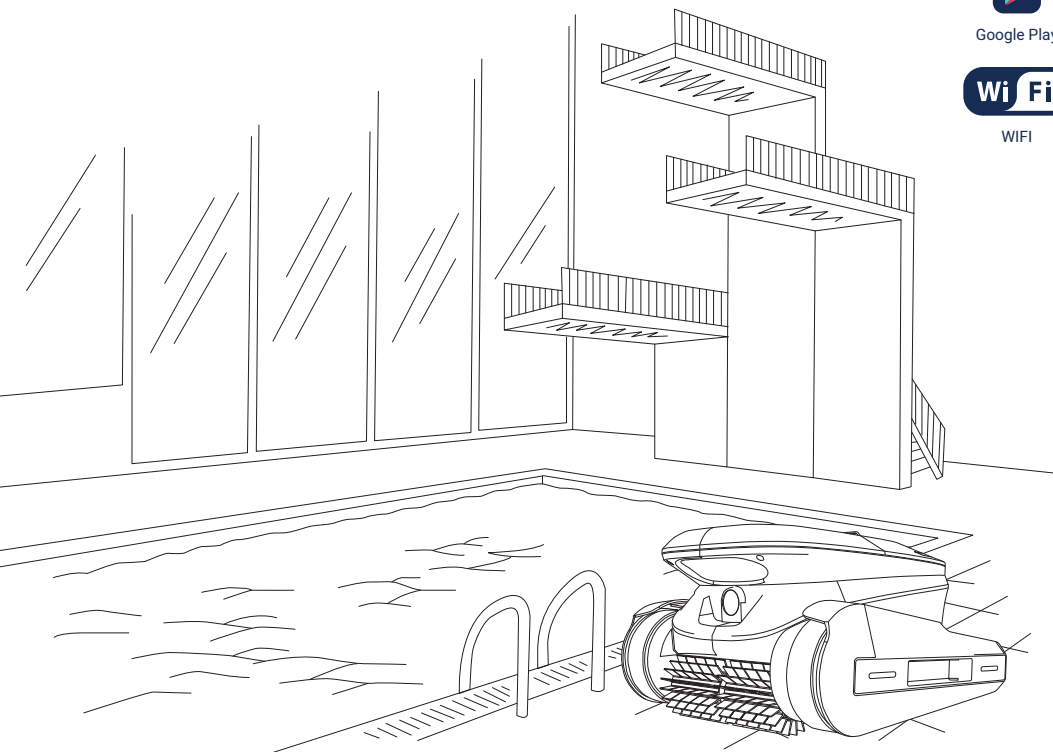

Contents

- PRODUCTION INTRODUCTIONS**03
- 1. WARNINGS AND CAUTIONS03
- 2. STRUCTURE04
- 3. PACKING LIST04
- 4. SPECIFICATIONS05
- 5. LED STATUS05
- 6. CLEANING MODES06

- USING THE POOL CLEANER**06
- 1. CHARGING06
- 2. PLACEMENT INTO THE POOL06
- 3. REMOVAL FROM THE POOL08
- 4. CLEANING08
- 5. USE THE SEAUTO IOT MOBILE APP09
- 6. RESET THE DEVICE12
- 7. REPLACEMENT OF BATTERY12

- OFF-SEASON STORAGE**13
- TROUBLE-SHOOTING & FAQ**13
- WARRANTY**16

PRODUCTION INTRODUCTIONS

Thank you for purchasing a Seauto Robotic Pool Cleaner.

Rest assured that your Seauto Robotic Pool Cleaner will provide you with reliable, convenient and cost-effective pool cleaning.

Its reliable filtration in all pool conditions, active brushing, and all-surface climbing brush ensures maximum pool hygiene.

The Robotic Pool Cleaners by Seauto deliver advanced cleaning technology and an intelligent, cable-free cleaning experience with easy maintenance. You and your family will be free to enjoy swimming with confidence that your pool is completely clean.

1. WARNINGS AND CAUTIONS

Read this manual carefully and use the device accordingly. We are not liable for any loss or injury caused by improper use of the device.

1. Be sure to charge the device before the first use.
2. Make sure the water depth of the pool is at least 19.5 in (50 cm) away from the top of the device, to achieve optimal cleaning performance.
3. The device comes with a lithium battery. Do not disassemble the sealed compartment without authorization. Protect the device from direct sunlight and impact. ⚠
4. Keep people and animals out of the pool while the device is in use. Do not leave children unsupervised while using the device. ⚠
5. Turn off the device before cleaning the filters.
6. During the off-season period, charge the device once a month to protect its battery.
7. Use the Pool Cleaner in the following water conditions only:

Chlorine	Max 4 PPM
pH	7.0 - 7.8 PPM
Temperature	41 - 95 °F (5 - 35 °C)
NaCl	Maximum = 5000 PPM

PRODUCTION INTRODUCTIONS

2. STRUCTURE

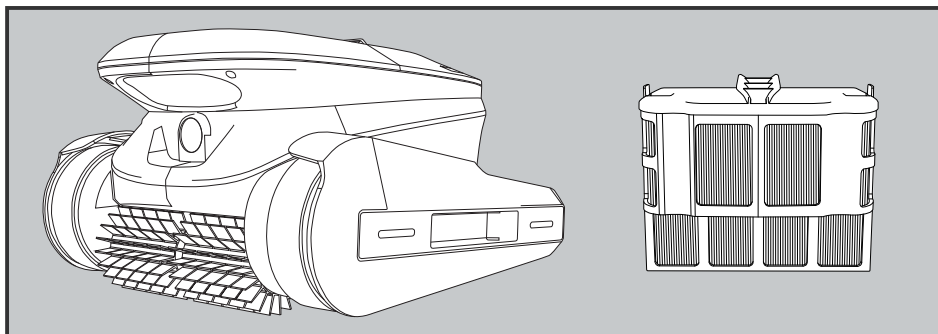

3. PACKING LIST

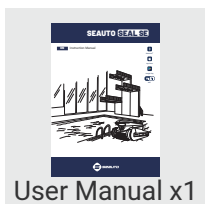
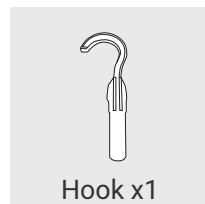

PRODUCTION INTRODUCTIONS

4. SPECIFICATIONS

Applicable pool size	Up to 2150 sq. ft (200 sq. m) inground pools
Water depth supported	1.6-3.3 ft (0.5-5 m)
Charger input	100-250 VAC, 50-60 Hz
Lithium battery capacity	7800 mAh
Battery life (default mode)	2-2.5 hours
Charging time	1.5-2 hours
Filtration system	250µm filter basket
Moving speed	40-80 ft/min (12-24 m/min)
Smart phone APP	iOS, Android
Connection Protocol	⌘ Bluetooth®, 📶 WIFI
Dimensions (L x W x H)	16.8*15.6*11.3 in / 426*396*287 mm
Net weight	19.18 lb / 8.7 kg
Waterproof level	IP68
Storage temperature	32 to 104°F (0 to 40°C)

5. LED STATUS

LED Color	Solid	Flashing
Blue ●	Working	Flash per 1 second: device is starting
		Flash per 3 seconds: device is idle
Red ●	Charging	Low battery
Green ●	Fully charged	-
Yellow ●	Resetting device	Device is abnormal
White ○	-	Firmware is updating

PRODUCTION INTRODUCTIONS

6. CLEANING MODES

Modes ^a	Cleaning Coverage	Voice Reminder ^b	Battery Life
All-cover mode ^c	Covers all areas	All-cover mode	2-2.5 hours
Wall-only mode	Only cleans the wall	Wall only	2-2.5 hours
Floor-only mode	Only cleans the floor	Floor only	2-2.5 hours

Note:

a) The modes can be selected in the App, or by pressing the switch button to shift.

b) When a mode is selected, it will give a voice alert of the current mode.

c) When turning on the machine, it will be in All-cover mode as default.

USING THE POOL CLEANER

1. CHARGING

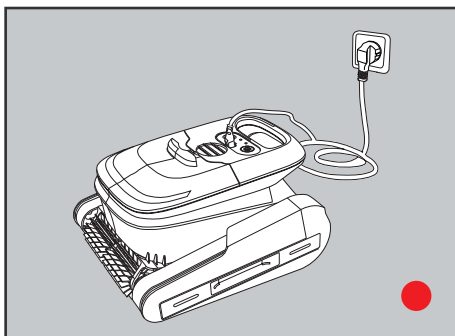

Connect to the power supply - it will then start charging. The LED light will be solid red.

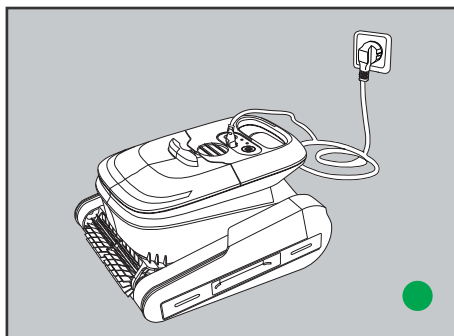

It will be solid green when the device is fully charged, then will turn off automatically in 10 minutes.

2. PLACEMENT INTO THE POOL

2.1 ALL-COVER MODE

Note: It comes in All-cover mode as default, the robot will cover all areas - including floor, wall and waterline.

USING THE POOL CLEANER

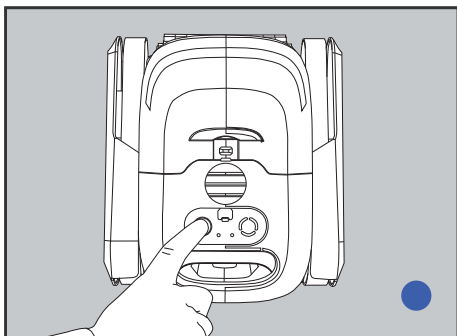

Press the button to turn it on - it will show a flashing blue light, and then it will say: "Welcome to the Seauto pool cleaning robot. I'm ready to work."

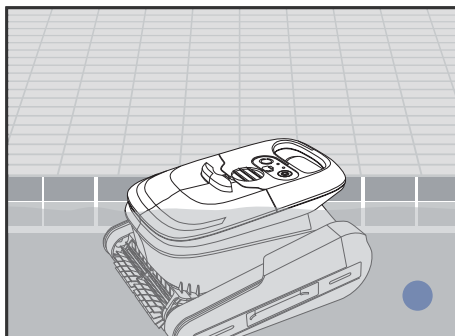

Put the device into the pool, making sure that the water surface is above the top of the machine to enable proper use. The LED light will turn to a solid blue when it starts cleaning the pool.

2.2 OTHER MODES

The cleaner has 3 modes available. It comes in All-cover mode, but you can select other modes in the APP or press the switch button to shift.

①. Press the switch button to select:

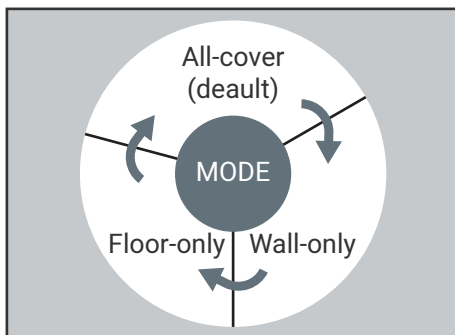
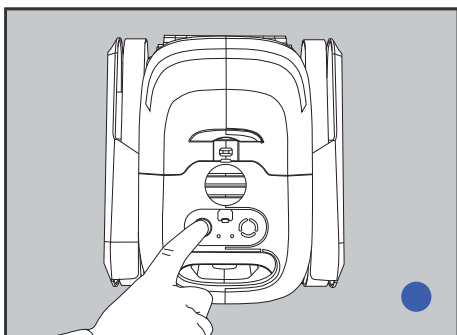

The cleaner will be in All-cover mode after turning it on. As shown above, each press will change the mode.

②. Select mode in the APP: please see [5. USE THE SEAUTO IOT MOBILE APP] on page 14.

USING THE POOL CLEANER

3. REMOVAL FROM THE POOL

Note: please attach the hook (included in your packaging) to a compatible pole, the pole is not included in the package. ⚠

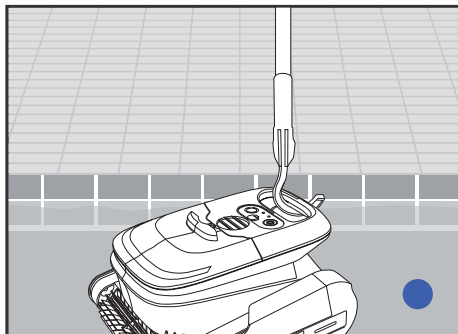

Hook up the machine by using a pole.

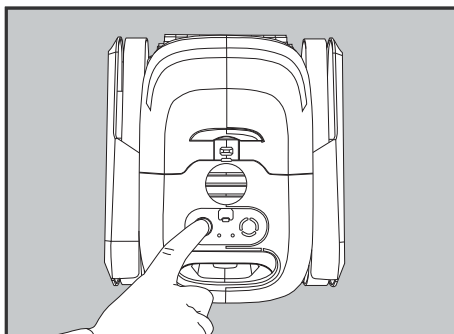

Before cleaning the filter, press and hold to switch off the cleaner.

4. CLEANING

Note: Clean the basket before it dries out. Make sure the machine is off.

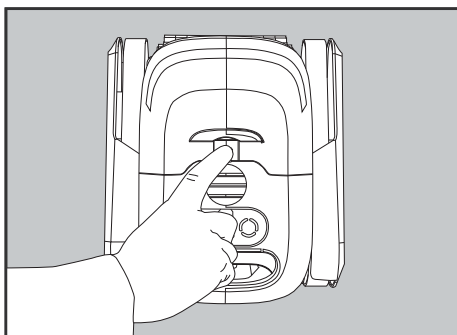

Press down the switch to open the lid.

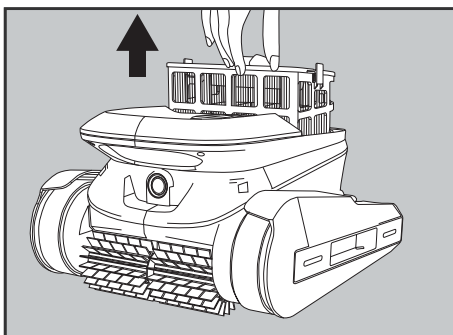

Remove the filter basket.

USING THE POOL CLEANER

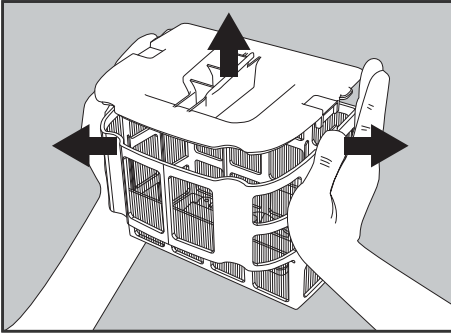

Open the cap of the basket.

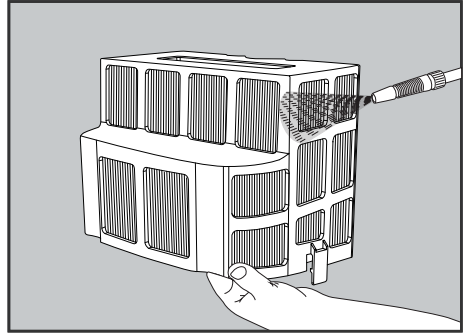

Clean the filter basket, then re-assemble it back into the device.

5. USE THE SEAUTO IOT MOBILE APP

Please download the Seauto app to your smart mobile device from either Google Play for Android or the App Store for iOS.

5.1 APP DOWNLOAD

Search “Seauto” in Google Play or in App Store, or scan the below QR code to download the app.

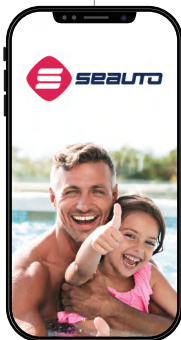

IOS



Android

USING THE POOL CLEANER

5.2 USER REGISTRATION



5.3 DEVICE CONNECTION

Note: please check following items before connection,

- a) Be sure the "Location" in your phone is turned on and allow the App to access the location.
- b) the Bluetooth on your phone is turned on. ✂
- c) there's WIFI coverage around. 📶
- d) your phone is close to the machine (within 16.4 ft / 5 m) for a better connection.



USING THE POOL CLEANER

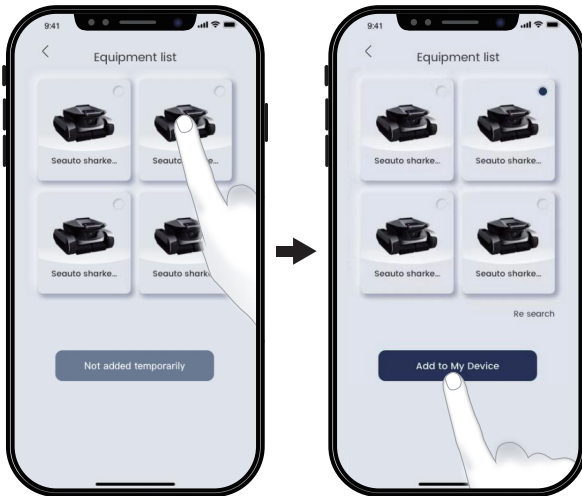

5.4 SELECT MODE AND SPEED

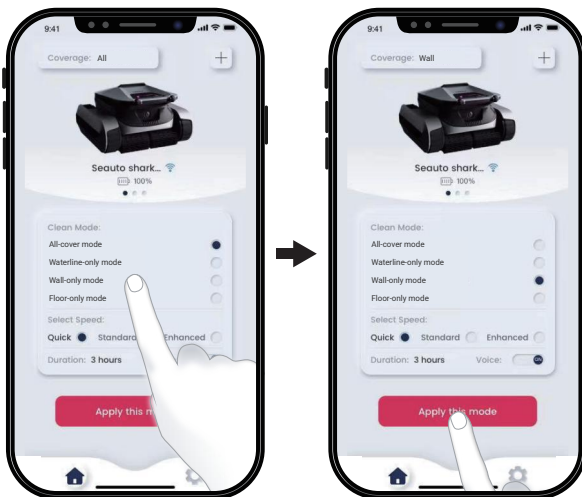

After selecting the mode you desire, you can now put it into your pool. It will start working according to the selected mode.

USING THE POOL CLEANER

6. RESET THE DEVICE

Attention: if the reset is confirmed, it will erase all settings, including the Bluetooth and WIFI connection history. ⚠

In the first 2 seconds after switching on, press and hold the button until the LED light turns white.

- ①. If you confirm to reset, please press the button once again, then the LED light will turn to a solid yellow and the device will start to reset.
- ②. If you don't want to reset, just wait for 10 seconds and then the LED light will turn to a shining blue. The cleaner now is ready to work.

7. REPLACEMENT OF BATTERY

Note: In case the performance of new battery being affected, before replacement please leave the machine stand for 2 days to ensure the complete evaporation of moisture. ⚠

Replacing the battery as follows to make pool cleaning robot an optimal cleaning state.

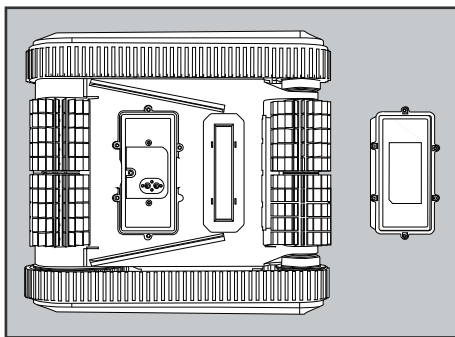

Remove the six screws that used to fix equipment and fetch out the used battery.

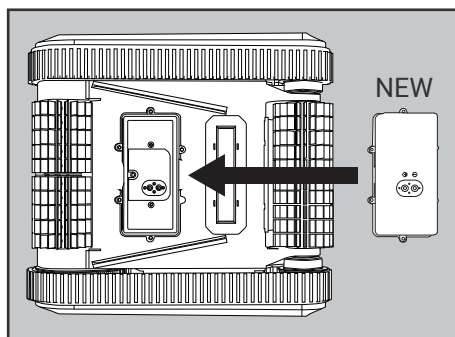

Insert the new battery according to the corresponding contacting positions of used battery.

Note: before putting in a new battery, clean up the water droplets/sand and other foreign objects in the contact position. ⚠

USING THE POOL CLEANER

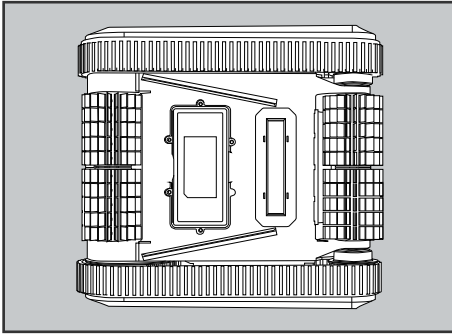

Installing, fixing and locking the screws.

OFF-SEASON STORAGE

If the pool cleaner will not be in use for an extended period, perform the following storage steps:

1. Make sure that no water is left in the pool cleaner.
2. Thoroughly clean the filter basket and insert them back into place.
3. Store the pool cleaner in a protected area out of direct sun/rain/frost at a temperature of between 5°-45°C / 41°-113°F.
4. Charge the pool cleaner once per month to protect the battery.

TROUBLE-SHOOTING & FAQ

If the suggested solutions do not solve the problem, please feel free to contact us.

Q: What kind of swimming pool is suitable?

A: It is recommended to use for in-ground pool (not exceed 2150sq.ft)

Q: Why doesn't the cleaner respond after turning on the machine?

A: The battery may be dead after a long-time delivery or storage. Please charge the device, the light will be solid red while charging.

TROUBLE-SHOOTING & FAQ

Q: Why can't it climb the wall?

A1: It may be set to the Floor-Only Mode. Connect it to the App and select the right mode.

A2: There is garbage or debris in the filter basket. You'll need to remove the basket and clean it.

Q: Why does the cleaner fall down when cleaning the wall instead of walking down along the wall?

A: It might suck up too much debris in the filter basket, thus the power of movement weakened.

Q: Why does the cleaner just sit at the bottom of the pool and not move or move slowly?

A1: It may be caught in the drain outlet on the floor. It will try to float itself to break free. If it is still stuck for several minutes, please use the pole to help.

A2: It may suck up lots of debris in a very short time if it's placed into a dirty pool, so check and clean the filters if needed.

Q: Why does the front part float while the rear part stays on the floor?

A: It's an intelligent feature of our pool cleaner, to break free from being stuck.

Q: Why can't my phone connect to the robot?

A: Please follow the below steps to link to the cleaner:

- a) Keep your machine turned on.
- b) Check and/or turn on the Bluetooth on your phone.
- c) Make sure your phone and the cleaner are in the same WIFI coverage area.
- d) Make sure your phone is in close enough range to the cleaner. (Within 16.4 ft / 5 m)

Q: Why can't the cleaner clean the wall or waterline in All-cover Mode?

A: It might suck up too much debris in the filter basket, thus the power of movement weakened.

Q: Is it possible to use the cleaner without a WIFI connection?

A: Yes, the cleaner comes in All-cover mode as default which cleans all pool areas, but you can select other modes in the App, or simply press the switch to change the mode.

TROUBLE-SHOOTING & FAQ

Q: Is it possible to connect the cleaner to the App without a WIFI connection?

A: No, the machine needs to be within WIFI coverage to connect to the app, as well as the Bluetooth on your phone, otherwise it will not be searched or be online on the app.

Q: How many smart phones can be connected to 1 cleaner?

A: Only 1 phone can be connected to the cleaner. You cannot connect to the machine by other smart phones. Please reset the cleaner or delete it in the App, if you want to link to another smart phone.

Q: Why does the cleaner automatically switch off after a few hours of charging?

A: It is designed to shut off automatically in 10 minutes after fully charged to protect the battery and ensure its lifespan. So, you can go out with confidence without worrying about charging safety.

Q: What is the issue when the cleaner lights up with a yellow or white light?

A: The yellow light means the cleaner has a problem (over-currented due to being stuck, or failure to start). Take the cleaner out and re-start it – it should then be ready to work.

The white light means that the robot is updating its firmware via WIFI. Make sure that the cleaner battery isn't low, and keep the WIFI connected during its update.

Q: How can I get replacement accessories?

A: Please contact your purchase channel. Or you can visit our website, or give us a call – we are available to help you out.

Q: How can I buy a long pole and what size is it?

A: We offer a pick-up hook in the box, which is the universal pool accessory – the hook fits a standard pole size with an 1-1/4" (25-32 mm) diameter connection end. You can easily find a pole in your local market or shop online.

Q: Why are there some water droplets inside a newly purchased machine?

A: As every machine is rigorously tested before leaving the factory, including underwater test, etc. So, there may be little water left inside, please feel free to use it normally.

WARRANTY

This product has passed all quality control and safety tests, conducted by the technical department of the factory.

1. The warranty is covered for 24 months for the machine and 12 months for the battery from the date of its original purchase.
2. There is no extension warranty for the consumables (filter net).
3. This warranty will be void if the product has been altered, misused, or has been repaired by unauthorized personnel.
4. The warranty extends only to manufacturing defects. It does not cover any damage resulting from mishandling of the product by the owner.
5. The order number or record must be presented for any claim or repair during the warranty period.
6. Please email or call us with any warranty issues, or visit our website for more information and support on accessories and consumables.



Tel: 800-618-8968

E-mail: support@seautorobots.com

Work time: Mon-Fri, 09:00-18:00 (EST)