



DHC-2 Beaver

INSTRUCTION MANUAL



Flyzone[™]
how high will you soar

RTF
READY-TO-FLY

Tx-R
TRANSMITTER-READY

SPECIFICATIONS

Wingspan:	59.5 in [1510mm]	Length:	38.5 in [980mm]
Wing Area:	430 in ² [27.7 dm ²]	Radio:	5-channel radio system
Weight:	3–3.25 lb [1360–1470 g]	Motor:	40mm dia. 850kV outrunner, 40A ESC, 12x6 propeller
Wing Loading:	16–17 oz/ft ² [49–52 g/dm ²]		

WARRANTY

Flyzone guarantees this kit to be free from defects in both material and workmanship at the date of purchase. This warranty does not cover any component parts damaged by use or modification. **In no case shall Flyzone's liability exceed the original cost of the purchased kit.** Further, Flyzone reserves the right to change or modify this warranty without notice.

In that Flyzone has no control over the final assembly or material used for final assembly, no liability shall be assumed nor accepted for any damage resulting from the use by the user of the final user-assembled product. By the act of using the user-assembled product, the user accepts all resulting liability.

If the buyer is not prepared to accept the liability associated with the use of this product, the buyer is advised to return

this kit immediately in new and unused condition to the place of purchase.

To make a warranty claim send the defective part or item to Hobby Services at the address below:

Hobby Services

3002 N. Apollo Dr. Suite 1
Champaign IL 61822 USA

Include a letter stating your name, return shipping address, as much contact information as possible (daytime telephone number, fax number, e-mail address), a detailed description of the problem and a photocopy of the purchase receipt. Upon receipt of the package the problem will be evaluated as quickly as possible.

READ THROUGH THIS MANUAL BEFORE STARTING CONSTRUCTION. IT CONTAINS IMPORTANT INSTRUCTIONS AND WARNINGS CONCERNING THE ASSEMBLY AND USE OF THIS MODEL.

TABLE OF CONTENTS

INTRODUCTION	2	Mount the Horizontal and Vertical Stabilizer	6
Academy of Model Aeronautics	2	Install the Battery	8
SAFETY PRECAUTIONS	2	Hook Up the Rudder and Elevator	8
REQUIRED FOR COMPLETION	3	Mount the Wings	9
Transmitter	3	Hook Up the Flaps and Ailerons	11
LiPo Battery	3	FINAL FLIGHT PREPARATION	12
Charger	3	Check the Control Throws	12
KIT INSPECTION	3	Check the C.G.	13
ORDERING REPLACEMENT PARTS	3	MOTOR SAFETY PRECAUTIONS	14
CONTENTS	4	MOTOR / ESC OPERATION	15
ASSEMBLY	5	FLYING	15
Mount the Landing Gear	5	REPAIRS	16
Mount the Floats	5		

INTRODUCTION

Thank you for purchasing the Flyzone 1/10th-scale de Havilland DHC-2 Beaver RTF/Tx-R. For anybody who enjoys flying float planes or who aspires to do so for the first time, the Flyzone Beaver is the perfect choice because it maneuvers and flies off the water so well—you virtually can't mess up a takeoff or landing unless you try! Of course, the Beaver is almost just as much at home on dry land as it is in the water. And with the flaps extended you can set your Beaver down on water or on land as light as a feather.

For the latest technical updates or manual corrections to the Beaver, visit the Flyzone site at www.flyzoneplanes.com. Open the "Airplanes" link, then select the Beaver ARF. If there is new technical information or changes to this model a "tech notice" box will appear in the upper left corner of the page.

Academy of Model Aeronautics

If you are not already a member of the AMA, please join! The AMA is the governing body of model aviation and membership provides liability insurance coverage, protects modelers' rights and interests and is required to fly at most R/C sites.

Academy of Model Aeronautics

5151 East Memorial Drive
Muncie, IN 47302-9252

Tele. (800) 435-9262

Fax (765) 741-0057



Or via the Internet at: <http://www.modelaircraft.org>

IMPORTANT!!! Two of the most important things you can do to preserve the radio controlled aircraft hobby are to avoid flying near full-scale aircraft and avoid flying near or over groups of people.

SAFETY PRECAUTIONS

PROTECT YOUR MODEL, YOURSELF AND OTHERS... FOLLOW THESE IMPORTANT SAFETY PRECAUTIONS

1. Your de Havilland Beaver should not be considered a toy, but rather a sophisticated, working model that functions very much like a full-size airplane. Because of its performance capabilities, the Beaver, if not assembled and operated correctly, could possibly cause injury to yourself or spectators and damage to property.
2. You must assemble the Beaver **according to the instructions**. Do not alter or modify the model, as doing so may result in an unsafe or unflyable model. In a few cases the instructions may differ slightly from the photos. In those instances the written instructions should be considered as correct.
3. You must use an R/C radio system that is in good condition. All components must be correctly installed so that the model operates correctly on the ground and in the air. You must check the operation of the model and all components before **every** flight.
4. If you are not an experienced pilot or have not flown this type of model before, we recommend that you get the assistance of an experienced pilot in your R/C club for your first flights. If you're not a member of a club, your local hobby shop has information about clubs in your area whose membership includes experienced pilots.
5. While this kit has been flight tested to exceed normal use, if the plane will be used for extremely high stress flying, such as racing, or if a motor or battery larger than ones in the recommended range is used, the modeler is responsible for taking steps to reinforce the high stress points and/or substituting hardware more suitable for the increased stress.

We, as the kit manufacturer, provide you with a top quality, thoroughly tested kit and instructions, but ultimately the quality and flyability of your finished model depends on how you build it; therefore, we cannot in any way guarantee the performance of your completed model, and no representations are expressed or implied as to the performance or safety of your completed model.

Remember: Take your time and follow the instructions to end up with a well-built model.

REQUIRED FOR COMPLETION

Other than a #1 and #2 Phillips screwdriver and a few drops of non-permanent threadlocker (GPMR6060), no adhesives or anything extraordinary is required to assemble the Beaver. The RTF is fully equipped with a complete radio control system, LiPo battery and charger, so no other accessories are required, but the following items are required to complete the Tx-R edition:

Transmitter

The Tx-R includes the Tactic™ TR624 6-Channel 2.4GHz receiver, so you'll need either a Tactic TX600 6-channel 2.4GHz transmitter, or any other 5-channel (or more) transmitter compatible with the Tactic *AnyLink*™ 2.4GHz radio adapter*. Using the *AnyLink* allows any compatible transmitter to work with the Tactic receiver.

- TX600 6-channel transmitter (TACJ2600)
- AnyLink radio adapter* (TACJ2000)

*In addition to the AnyLink radio adapter, some AnyLink-compatible transmitters may also require additional adapter cables. Visit Tx-Ready.com to see the *AnyLink* compatibility chart or contact Product Support at the contact information on this page.

LiPo Battery

The RTF edition of the Beaver includes a Flyzone 3S (11.1V) 1800mAh 20C LiPo battery and the same is recommended for the Tx-R, but a 2100mAh battery is also an option for slightly longer flight times (more about flying time on page 15).

- Flyzone 3S (11.1V) 1800mAh 20C LiPo battery (HCAA6430)
- Flyzone 3S (11.1V) 2100mAh 20C LiPo battery (HCAA6387)

Spare batteries may also be purchased and charged at home ahead of time, eliminating the wait between flights for batteries to charge at the field.

NOTE: The Flyzone batteries suggested are equipped with a SuperTigre® battery connector that fit the connector on the ESC. If using a different LiPo battery that has a Deans® connector, a SuperTigre-to-Deans adapter (SUPM0040) will be required, or the battery connector on the ESC may be

replaced with a Deans Ultra Plug® male connector which will require soldering (but is a simple task for those so equipped).

Charger

The RTF comes equipped with a Great Planes 3S LiPo balancing *Smart Charger*, but the Tx-R requires a charger to be purchased separately. The *Smart Charger* is a safe way to charge your LiPo battery, but it's very basic and just enough to get you started. The Smart Charger charges at a rate of .8 Amps, so it will take at least one-and-a-half hours or more to charge your battery. For those who have the RTF and wish to upgrade their charger, or those with the Tx-R who must purchase a charger anyway, the Duratrax® Onyx™ 235 AC/DC Advanced Peak Charger (DTXP4235) is recommended. The Onyx is perfect for 3S batteries used with the Beaver and may be powered either by an external DC power source (such as a 12V battery), or a 110V AC outlet. The Onyx also has an adjustable charge rate to charge your batteries in as little as a half-hour or less (depending on the condition of your batteries and the manufacturer's specified charge rate). The Onyx can also charge larger batteries and batteries other than LiPos, so it is a versatile charger you can grow into. Finally, the 235 features an LCD digital display screen, so you can see how much capacity it took to recharge the battery (required for monitoring the condition of your batteries and calculating how long you can fly).

NOTE: For use with the Onyx 235, LiPo batteries that come with a SuperTigre connector (such as the Flyzone batteries recommended) require a banana plugs-to-SuperTigre charge lead (SUPM0070). And batteries that come with a Deans Ultra Plug connector require a Charge Lead with banana plugs/Deans Ultra Plug Male charge lead (GPMM3148).

KIT INSPECTION

Before assembly, take an inventory of this kit to make sure it is complete, and inspect the parts to make sure they are of acceptable quality. If any parts are missing or are not of acceptable quality, or if you need assistance with assembly, contact **Product Support**. When reporting defective or missing parts, use the part names exactly as they are written in the Contents list.

Flyzone Product Support
3002 N Apollo Drive Suite 1
Champaign, IL 61822

Ph: (217) 398-8970 ext. 5
Fax: (217) 398-7721

E-mail: airsupport@flyzoneplanes.com

ORDERING REPLACEMENT PARTS

Replacement parts for the Flyzone de Havilland Beaver RTF/Tx-R are available using the order numbers in the **Replacement Parts List** that follows. The fastest, most economical service can be provided by your hobby dealer or mail-order company.

To locate a hobby dealer, visit the Flyzone web site at www.flyzoneplanes.com. Click on the Storefront icon at the top of the page to load the Flyzone Dealer Locator. Follow the instructions provided on the page to locate a U.S., Canadian or International dealer.

Parts may also be ordered directly from Hobby Services by calling (217) 398-0007, or via facsimile at (217) 398-7721, but full retail prices and shipping and handling charges will apply. Illinois and Nevada residents will also be charged sales tax. If ordering via fax, include a Visa® or MasterCard® number and expiration date for payment.

Mail parts orders **Hobby Services**
 and payments by 3002 N Apollo Drive, Suite 1
 personal check to: Champaign IL 61822

Be certain to specify the order number exactly as listed in the **Replacement Parts List**. Payment by credit card or personal check only; no C.O.D.

If additional assistance is required for any reason contact Product Support by e-mail at productsupport@flyzoneplanes.com, or by telephone at (217) 398-8970.

REPLACEMENT PARTS LIST	
ORDER NO.	DESCRIPTION
FLZA6265	Fuselage Set
FLZA6266	Wing Set
FLZA6267	Horizontal Stab
FLZA6268	Vertical Fin
FLZA6269	Main Landing Gear
FLZA6270	Tail Wheel Set
FLZA6271	Cowl
FLZA6272	12x6 Propeller
FLZA6273	Spinner
FLZA6274	Prop Adapter
FLZA6275	Float Set
FLZA6276	Float Brackets

ORDER NO.	DESCRIPTION
FLZA6277	Water Rudders
FLZA6278	Wing Clips
FLZA6279	Hatch Set
FLZA6280	41-19-850 Motor
FLZA6281	40 Amp ESC
FLZA6282	Main Wheels
FLZA6283	Servo
FLZA6284	Wing Strut Set
FLZA6285	Decal Sheet
FLZA6024	Flyzone LiPo Battery 3S 11.1V 1800mAh 20C
TACJ2600	Tactic TTX600 6Ch SLT 2.4GHz Radio System No Servos
TACL0624	Tactic TR624 6-Channel SLT 2.4GHz Receiver
GPMM3318	Great Planes AC/DC 3S LiPo Balancing Smart Charger

CONTENTS

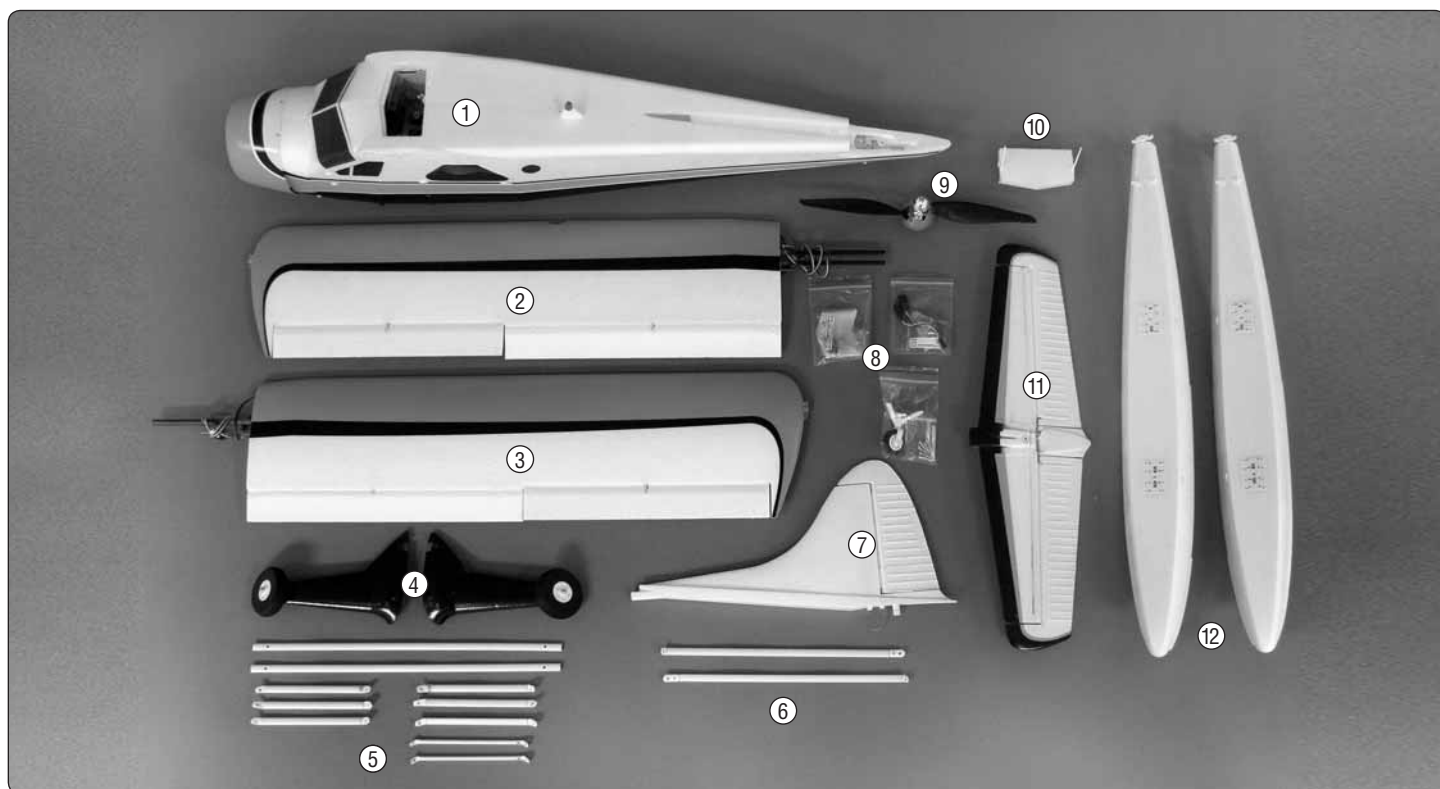

- | | | |
|----------------------|------------------------|-------------------------------|
| 1. Fuselage | 5. Float Brackets | 9. Propeller/Spinner Assembly |
| 2. Left Wing | 6. Wing Struts | 10. Top Hatch |
| 3. Right Wing | 7. Vertical Stabilizer | 11. Horizontal Stabilizer |
| 4. Main Landing Gear | 8. Hardware | 12. Floats |

ASSEMBLY

NOTE: This instruction manual applies to *both* the RTF and Tx-R editions of the de Havilland Beaver. If assembling the RTF edition, simply skip steps that do not apply.

Mount the Landing Gear

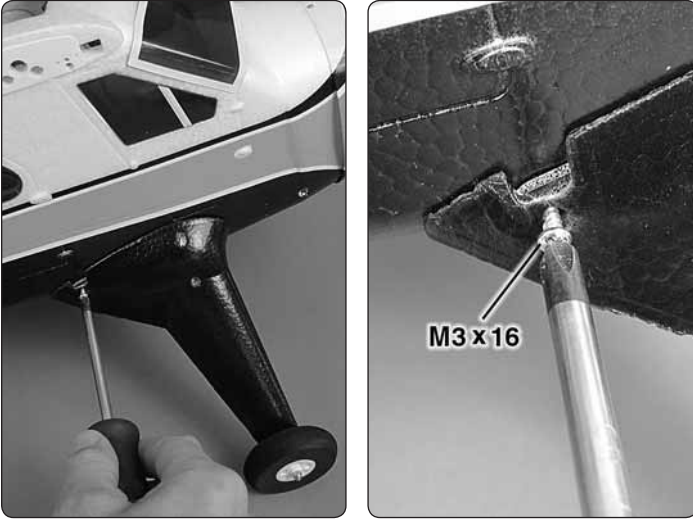

- 1. Use a #2 Phillips screwdriver to fasten both main landing gears to the fuselage with three M3x16 screws in each side.

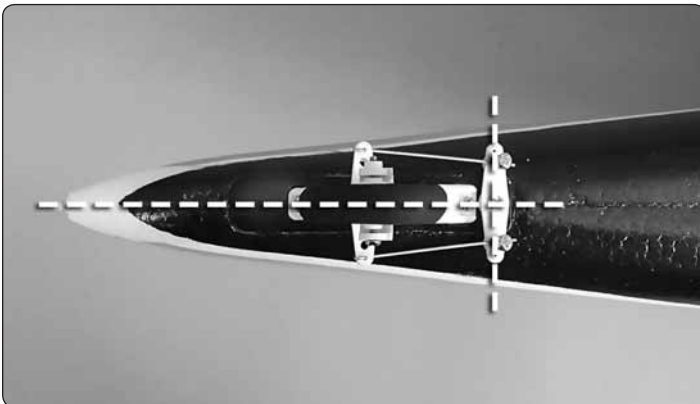
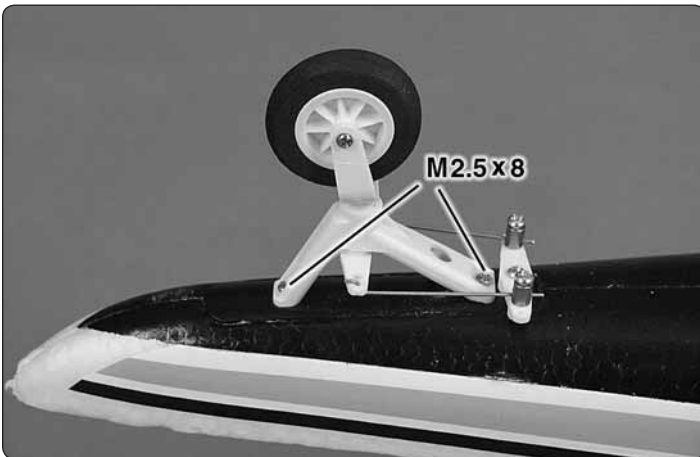

- 2. Mount the tail gear with two M2.5x8 screws, then fasten the pushrod wires as shown. Make sure the tail wheel is perpendicular with the steering arm.

Mount the Floats

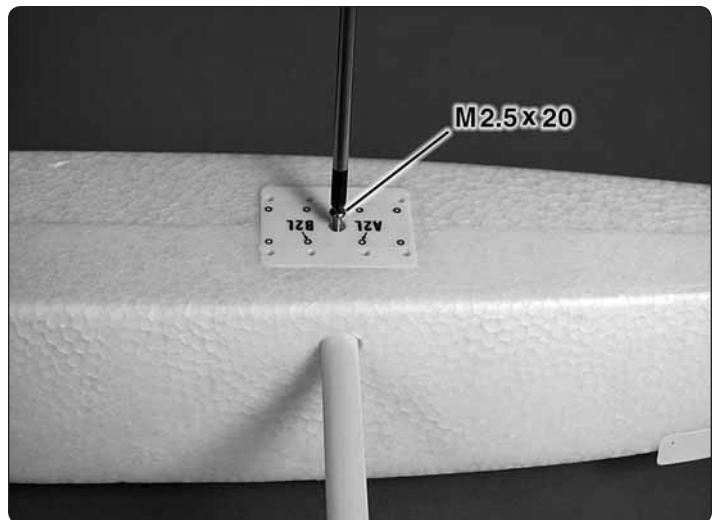
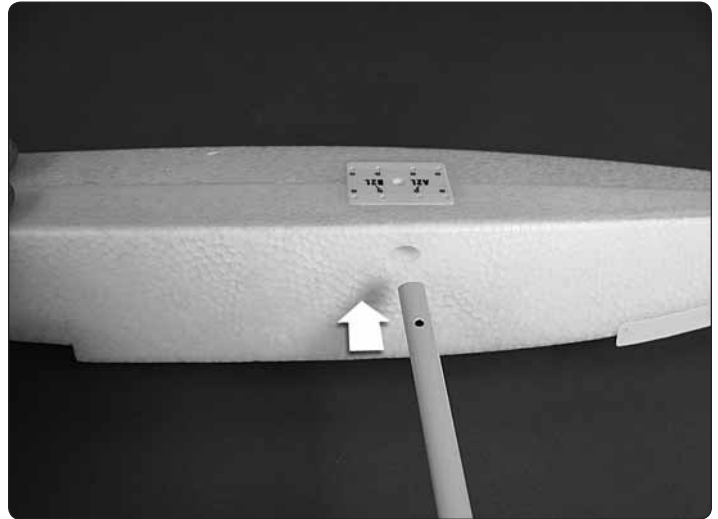

- 1. Connect the floats to each other with the horizontal struts and four M2.5x20 machine-thread screws.

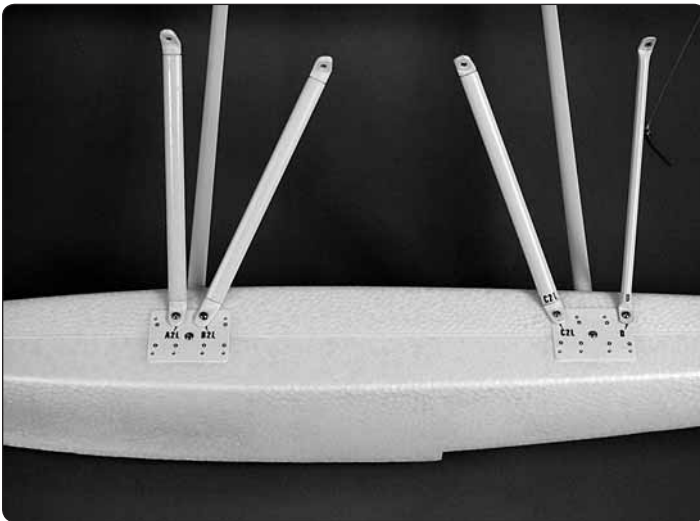
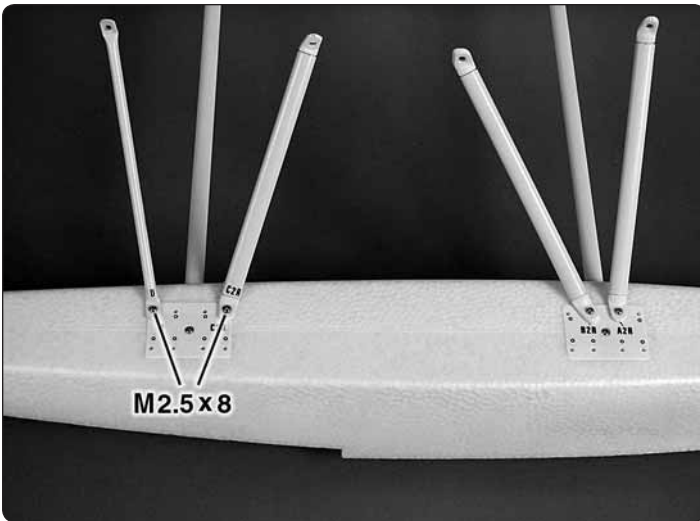

❑ 2. Use eight M2.5x8 screws to fasten the braces to the floats, matching the labels printed or molded into the end of each brace to each mount location on each float.

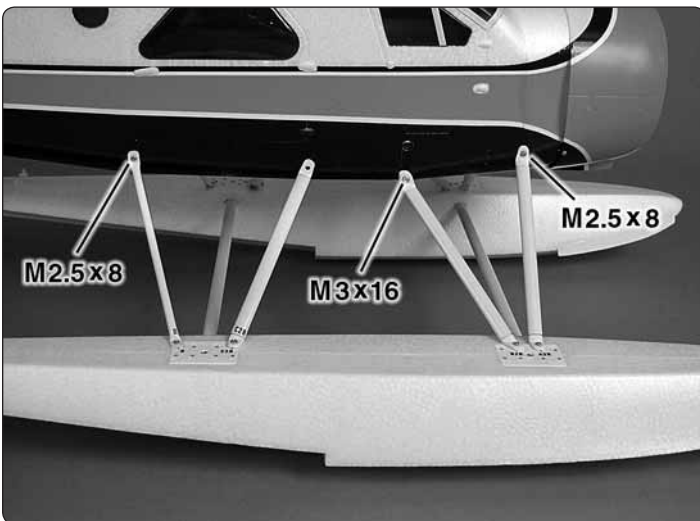

❑ 3. Fasten the float braces to the fuselage with one M3x16mm screw and two M2.5x8mm screws in each side of the fuselage.

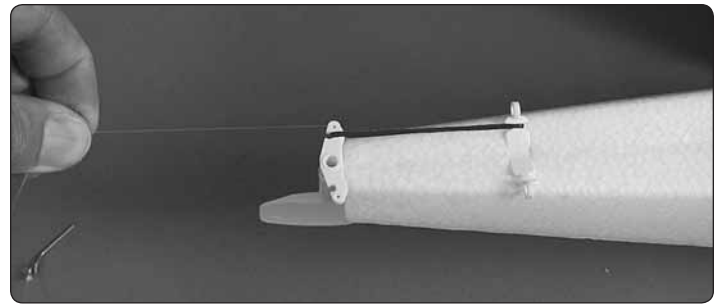

❑ 4. Connect a small rubber band to each float and water rudder as shown.

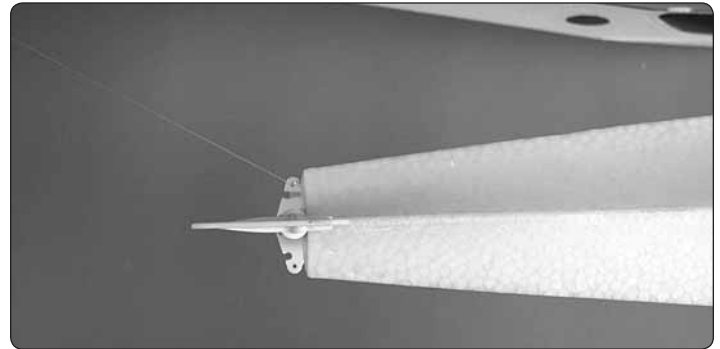
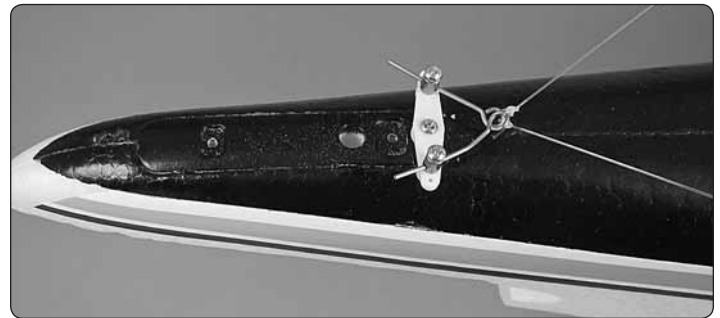

❑ 5. Fasten the wire hooks on the end of each rudder line to the connectors in the steering arm. As best as you can, adjust the tension in the lines to center the water rudders—the rudders don't have to be **perfectly** centered, because over time they may drift anyway, and the rudders are forgiving and overall water handling is easy.

Mount the Horizontal and Vertical Stabilizer

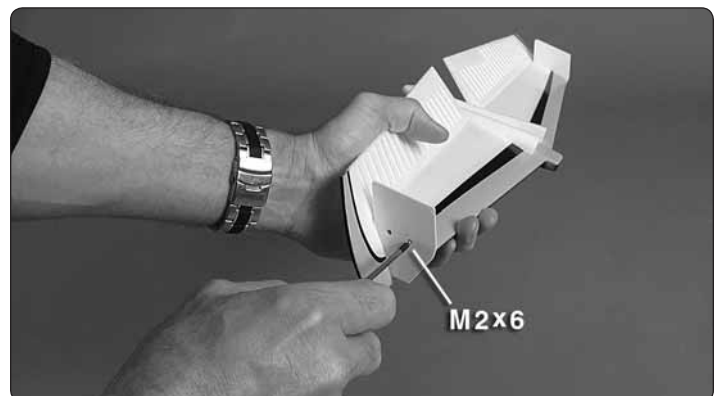

❑ 1. Fasten the vertical stabilizers to each end of the horizontal stabilizer (stab) with M2x6 screws.

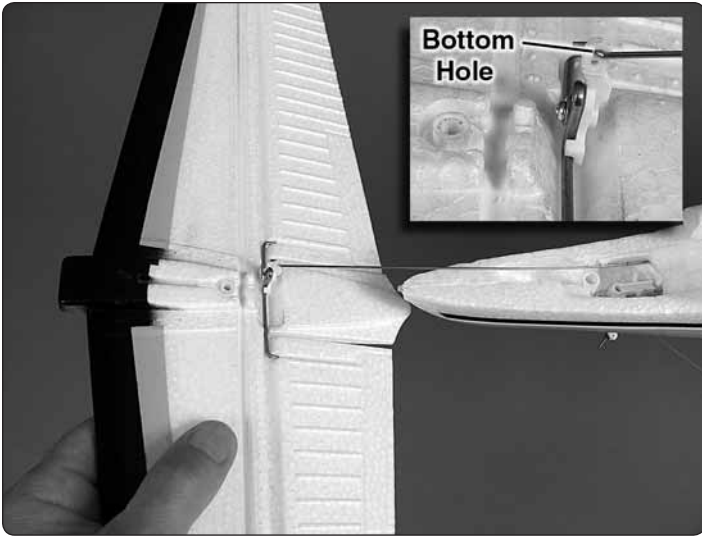

❑ 2. Connect the elevator pushrod to the bottom hole in the elevator horn as shown.

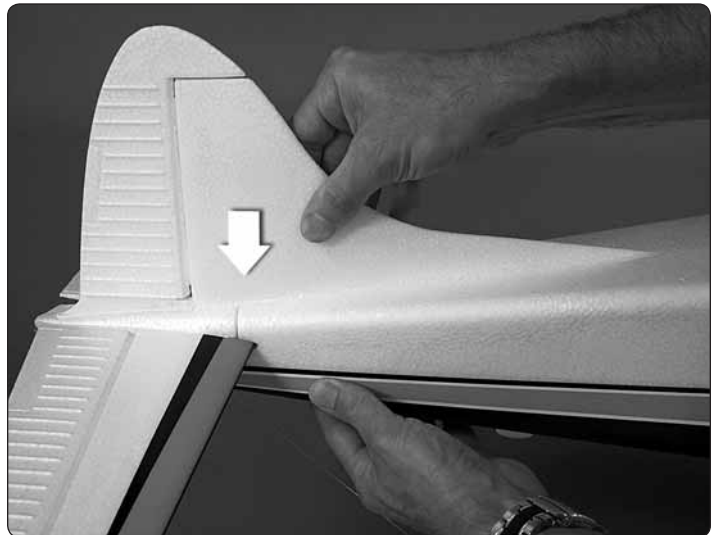
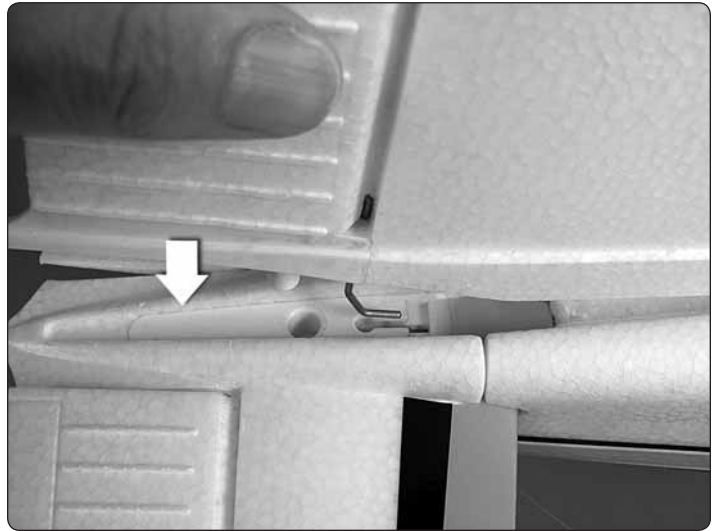
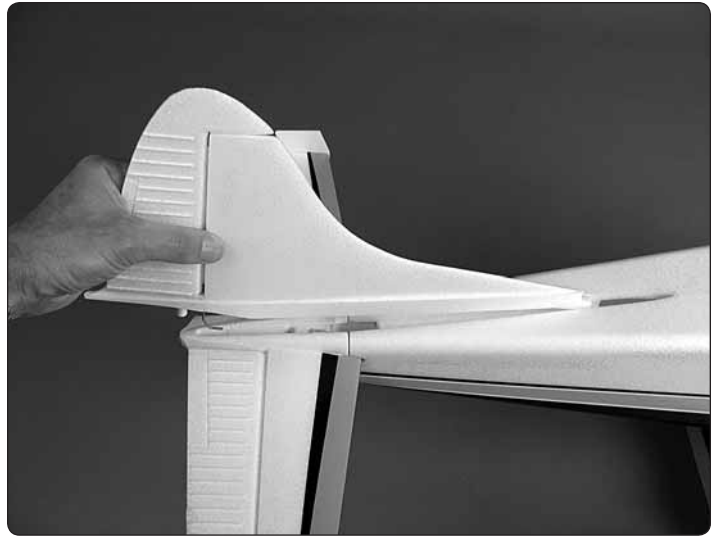

❑ 4. Key the rudder torque rod down into the receptacle while fitting the vertical stabilizer (fin) into the fuselage. Tightly press the assembly down into position.

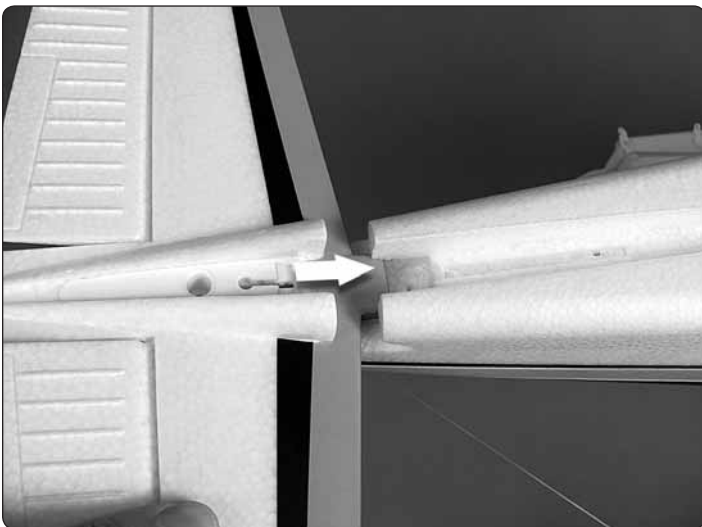
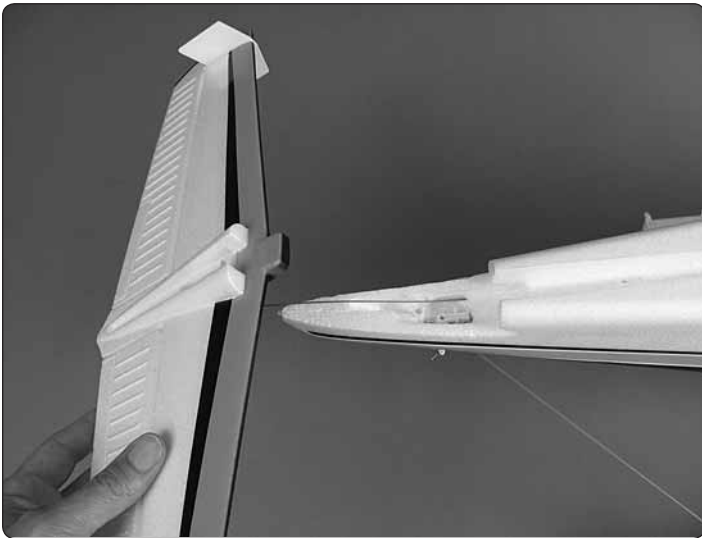

❑ 3. Rotate the stab upward and key it into the fuselage.

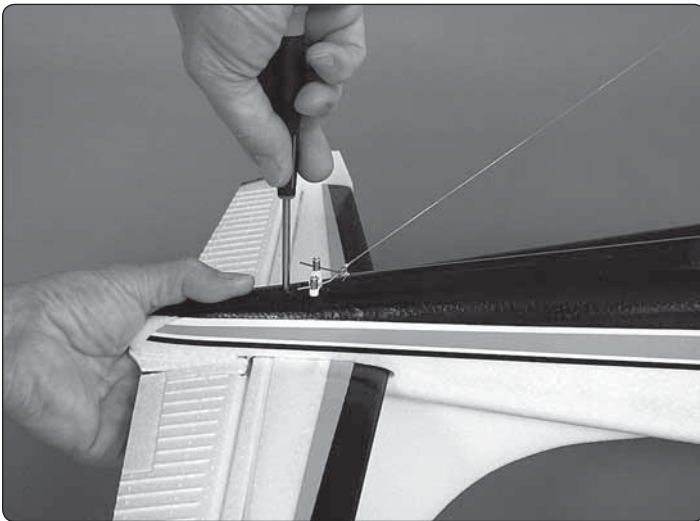
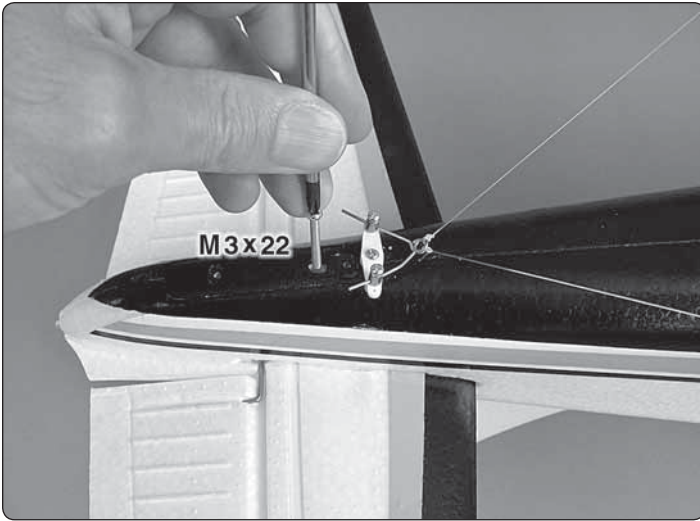

- ❑ 5. Secure the stab and fin with the M3x22 screw.

Install the Battery



- ❑ 1. Cut two 1" [25mm] strips from the rougher, "hook" side of the included adhesive-back hook-and-loop material. Apply the strips inside the fuselage where shown and press them down tightly so they adhere.

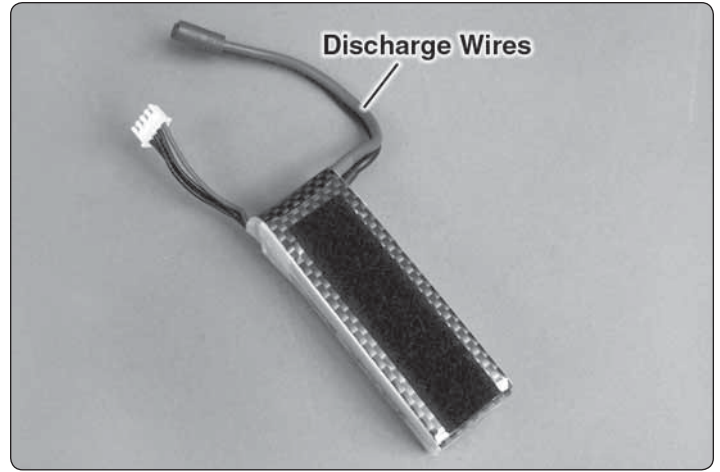

- ❑ 2. Cut a 3" [76mm] strip from the softer, "loop" side and attach it to the battery so the larger "discharge" wires will be on the right side as shown. (This will position the wires opposite the receiver for a better fit.)

Hook Up the Rudder and Elevator

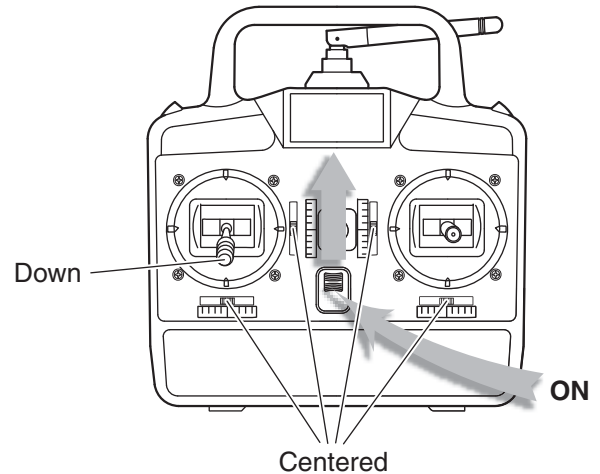

- ❑ 1. Turn **on** the transmitter, **lower** the throttle stick all the way, **center** the trims and make sure the throttle channel in your transmitter is in the "**reverse**" position.

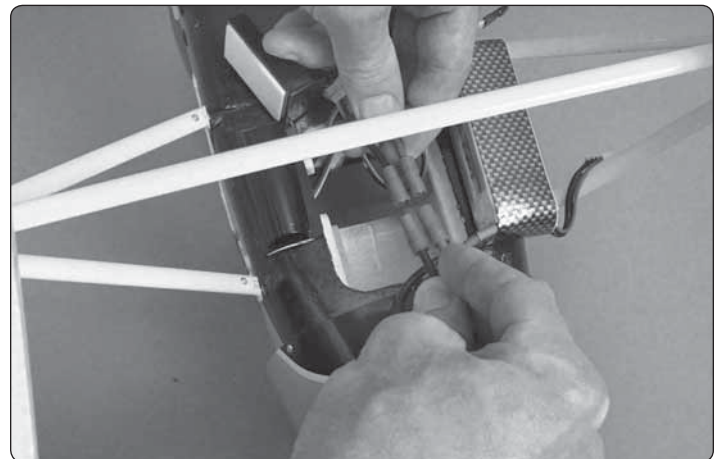

- ❑ 2. Connect the battery to the ESC. If all is working properly, the ESC will send three, short, electrical pulses to the motor causing it to chime three times ("♪1-2-3") followed by a longer,

single, lower tone beep (“BEEEP”) followed by a shorter, higher tone beep (“beep”). If the chimes and beeps do not sound in this manner refer to “**MOTOR/ESC OPERATION**” on page 15 to setup the transmitter and ESC correctly.



A magnetic screwdriver, or a small magnet stuck to a screw driver to make it magnetic, will be helpful for the next couple of steps.

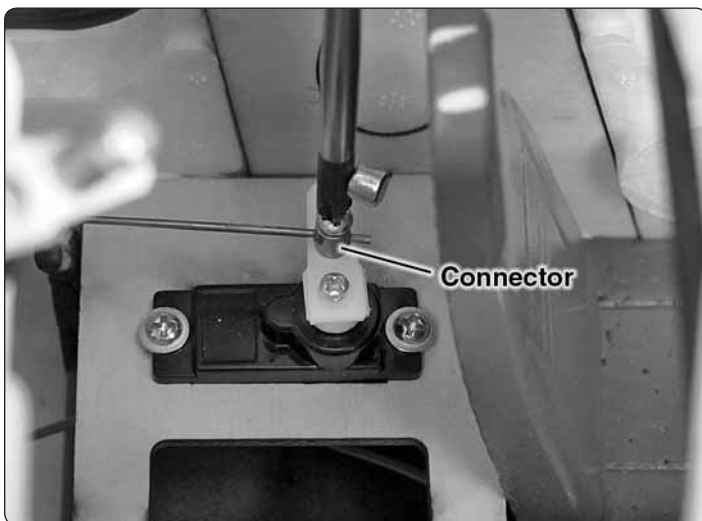

❑ 3. Remove the screw from the connector on the **elevator** servo arm.



❑ 4. **Lightly** wet the threads of the screw with threadlocker.

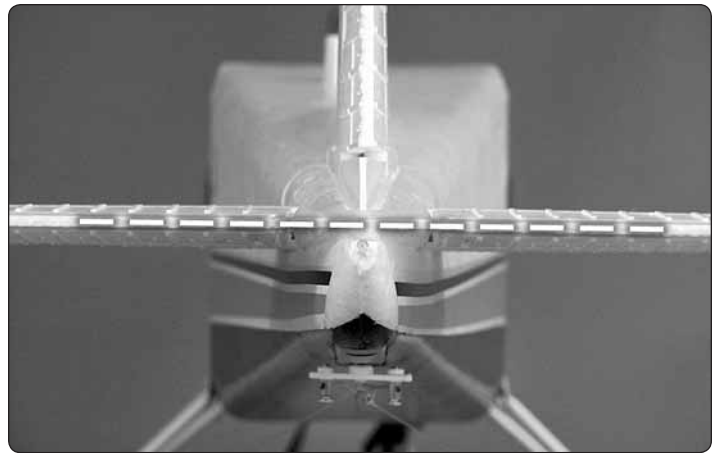

❑ 5. Reinstall the screw, but do not tighten yet. **With the transmitter and receiver on**, center the elevator and tighten the screw to lock the pushrod down.

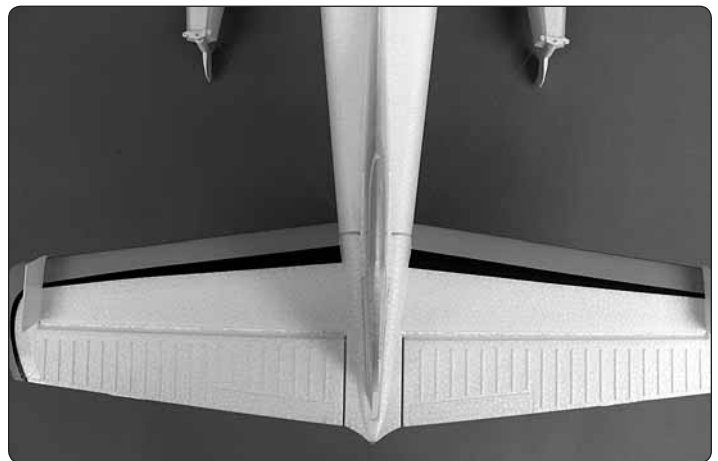

❑ 6. Repeat the same procedure for the rudder, making sure it is centered. Lock the pushrod down with the screw and threadlocker.

❑ 7. Disconnect the battery and turn off the transmitter.

Mount the Wings

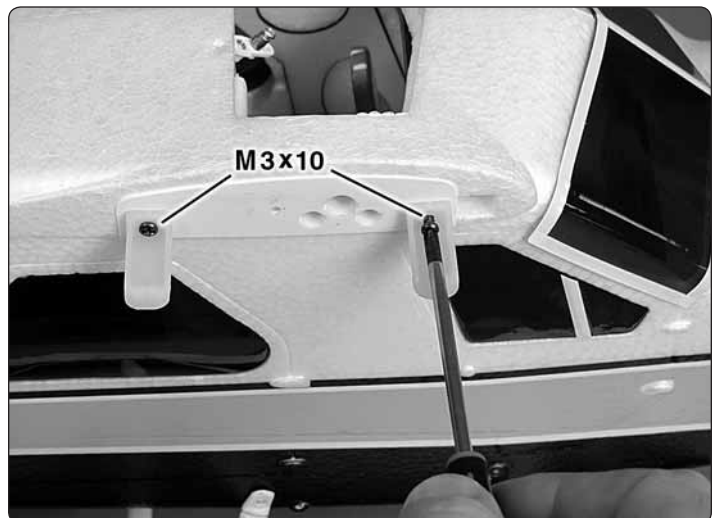

❑ 1. Fasten the **wing clips** to both sides of the fuselage with four M3x10 screws.

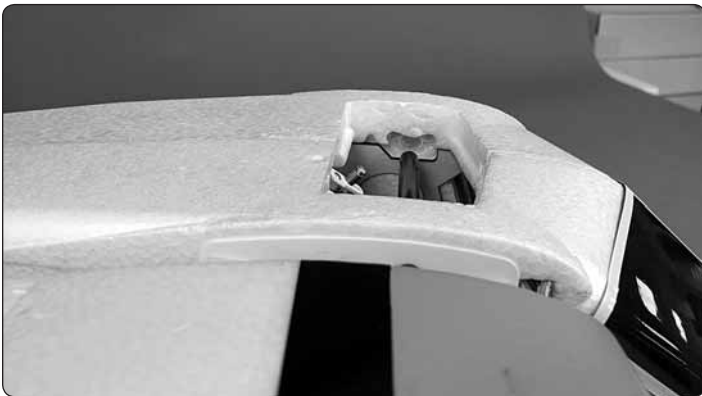
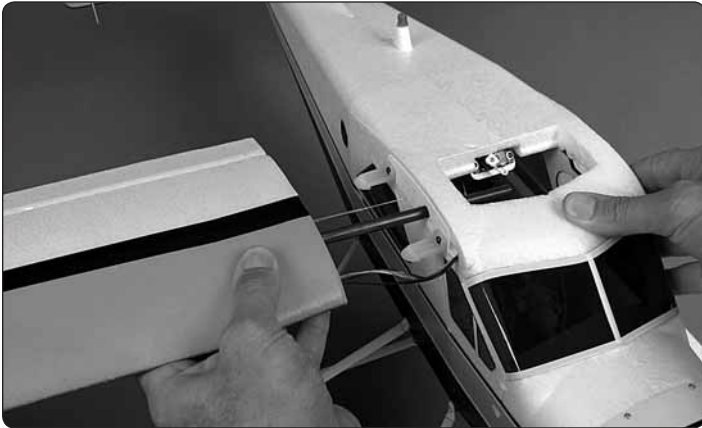
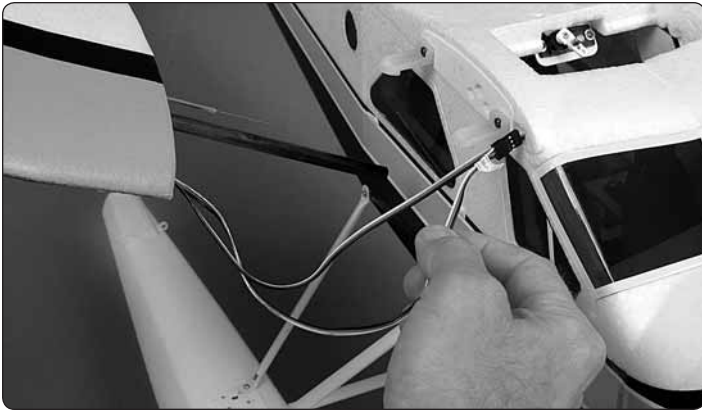

❑ 2. Guide the wires from the right wing into the fuselage, then slide the wing joiner tube and the flap pushrod wire through the corresponding holes. Also guide the flap pushrod wire into the screw-lock connector on the flap servo. Guide the joiner tube through the hole in the left side of the fuselage, then tightly “CLICK!” the wing onto the wing clips.

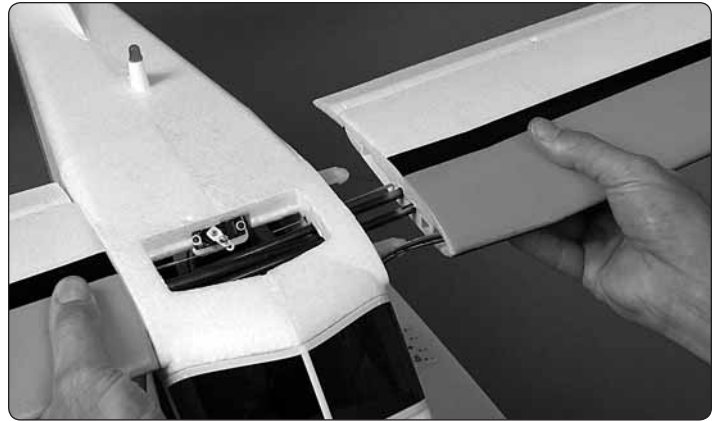

❑ 3. Mount the left wing the same way.

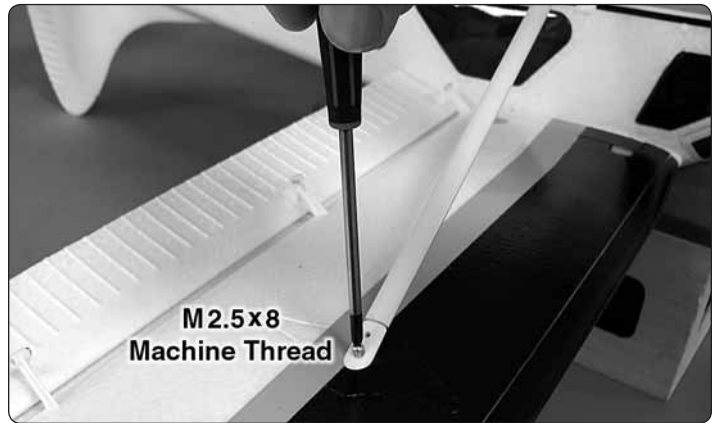

❑ 4. Mount the top of each wing strut to the wing with an M2.5x8 machine-thread screw.

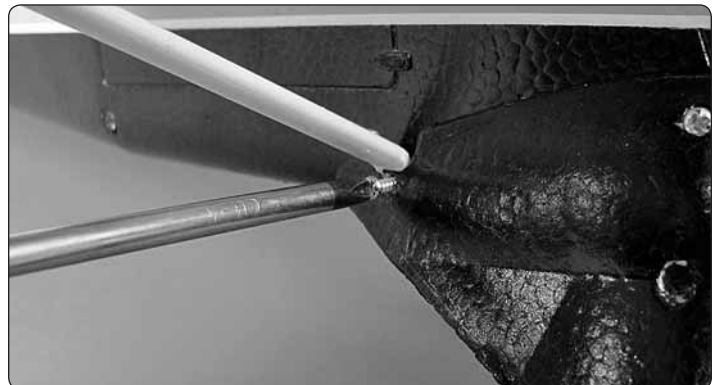

❑ 5. Mount the bottom of each strut to the fuselage over the float strut (or over the main landing gear) with an M3x16 screw.

Hook Up the Flaps and Ailerons



❑ 1. Connect the **wing lighting wires** and the **aileron servo wires** to the lighting and flap wiring harnesses coming from the receiver.

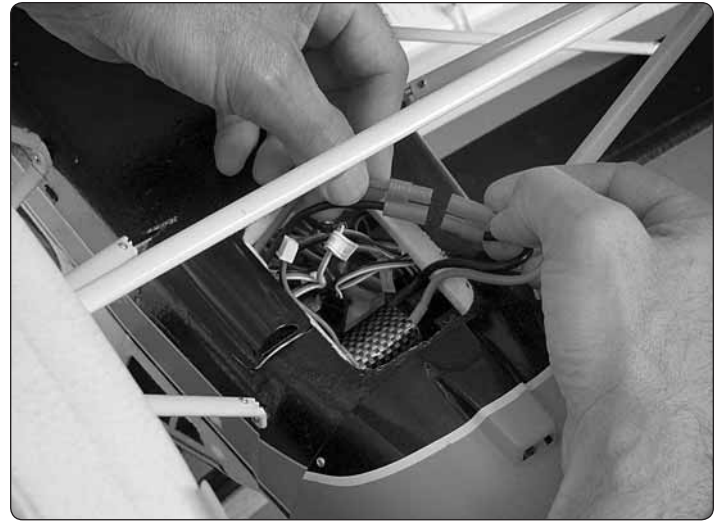

❑ 2. Turn on the transmitter and install and connect the battery. Then install and secure the hatch.

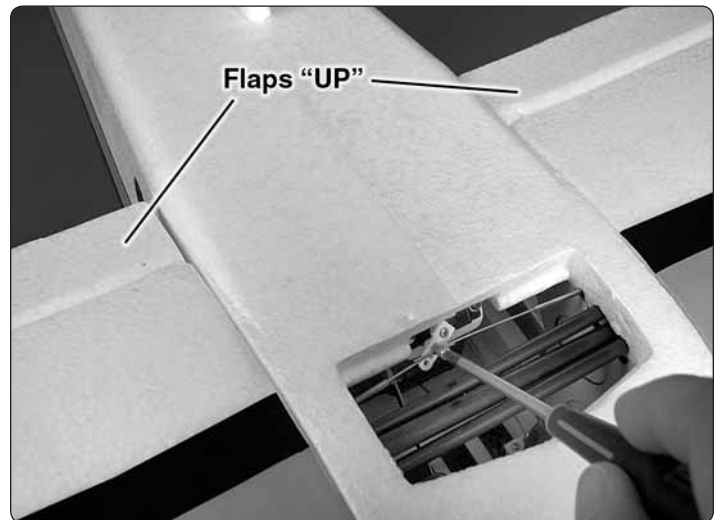

❑ 3. Move the dial or switch on your transmitter that controls the flaps to the "up" position, rotating the flap servo arm **clockwise**. Remove the screw in the flap servo arm, wet the threads with threadlocker, and then reinstall and tighten the screw so the flaps will be in their fully **retracted** ("up") position.

FINAL FLIGHT PREPARATION

Check the Control Throws

Because the servos and pushrods are factory-installed the control throws should already be correct, but because of the effect the control throws can have on a model, it's always a good idea to check them anyway.

4-Channel Radio Set Up (Standard Mode 2)

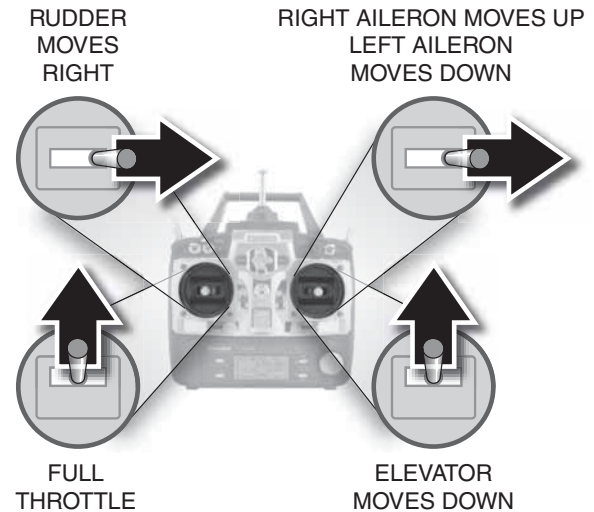

❑ 1. Confirm that the controls are responding in the correct direction according to control inputs from the transmitter. If necessary, use the servo reversing program in your transmitter to change the servo direction of any controls that are moving the wrong way.

❑ 2. If your de Havilland Beaver is configured with wheels, use a small box or something similar to prop up the bottom of the fuselage under the tail so the wings and stab are level (or nearly level).

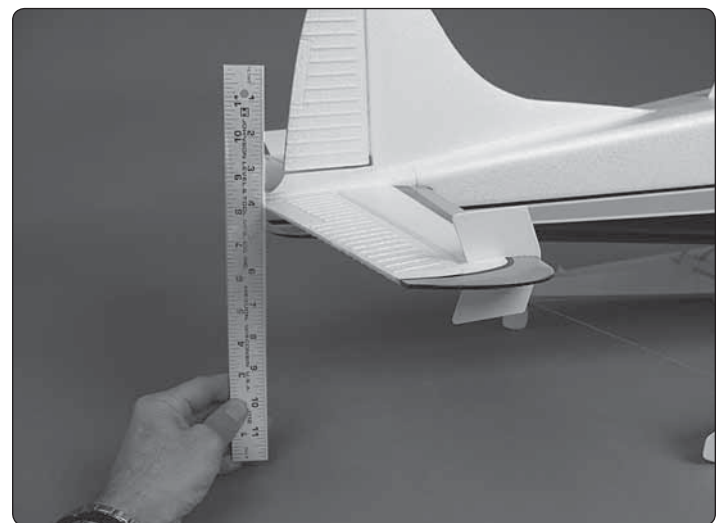

❑ 3. Measure and set the control throws according to the measurements below. The throws are measured at the **widest** part (front-to-back) of each surface.

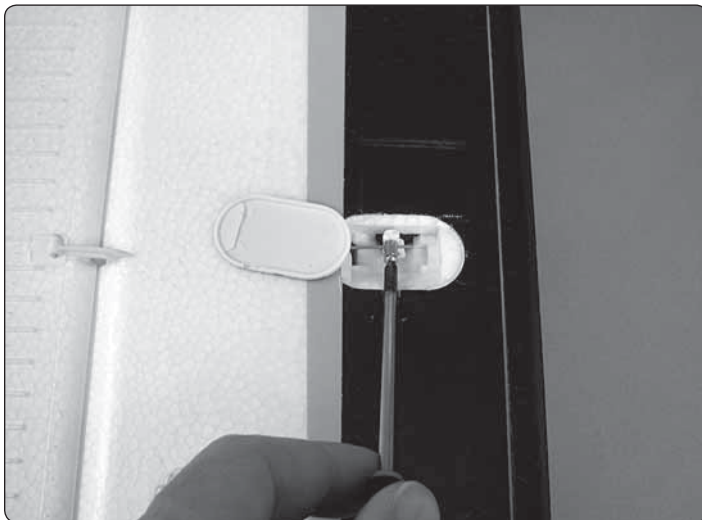
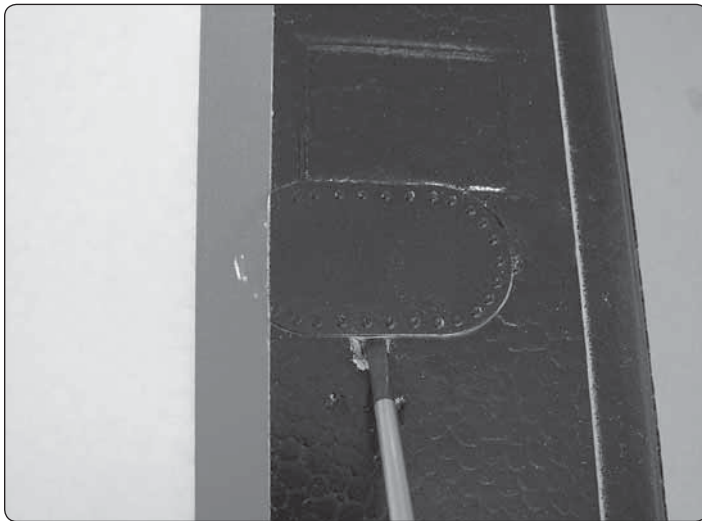
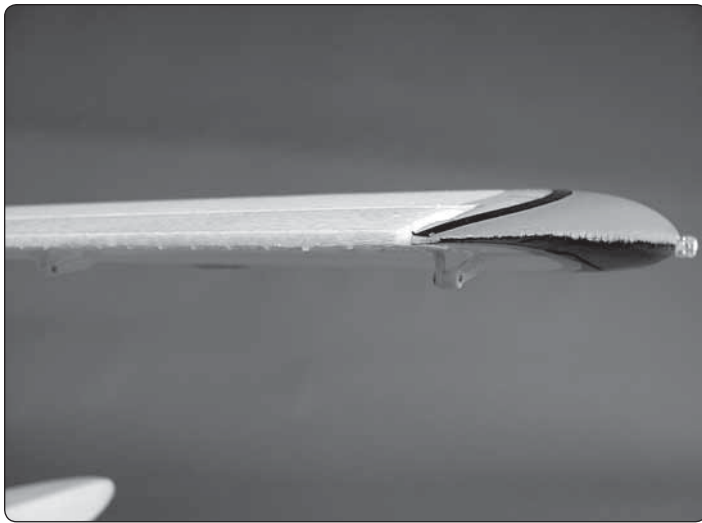

❑ 4. With the system still on, make sure the ailerons are centered and aligned with the wing tips. If necessary, apply a few clicks of aileron trim to get the ailerons centered. If more than a few clicks of trim are required, or if you cannot get both ailerons neutralized, a small screwdriver may be used to pop off one or both **flap servo covers** to access the pushrods. Adjust the pushrods in the connectors to get the ailerons centered. When finished, replace the cover, press into position, and hold in place with tape or a dab of glue.

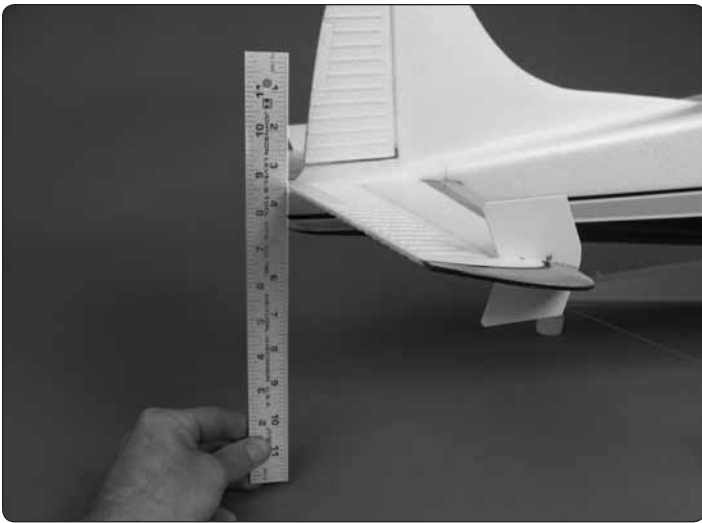

More Control Throw

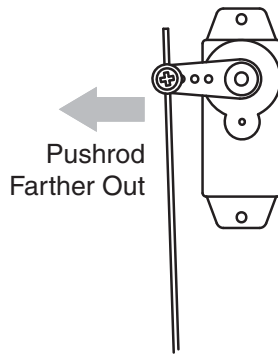

Less Control Throw

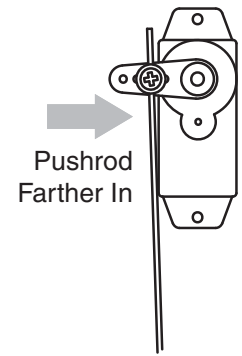

4. If any of the control throws require adjustment use the programming in your transmitter to increase or decrease the throws accordingly. If the programming isn't enough or if your radio doesn't have adjustable throws, the pushrod connectors on the servo arms can be relocated in different holes inward or outward to increase or decrease the throw—moving the pushrods **inward** on the servo arms **decreases** the throw and moving the pushrods **outward** on the servo arms **increases** the throw.

Recommended Control Surface Throws				
INCHES	HIGH RATE		LOW RATE	
	Up	Down	Up	Down
ELEVATOR	7/16"	7/16"	5/16"	5/16"
AILERONS	1/2"	1/2"	3/8"	3/8"
RUDDER (R&L)	1-1/4"	1-1/4"	7/8"	7/8"
FLAP		7/16"		

Recommended Control Surface Throws				
MILLIMETERS	HIGH RATE		LOW RATE	
	Up	Down	Up	Down
ELEVATOR	11 mm	11 mm	8 mm	8 mm
AILERONS	13 mm	13 mm	10 mm	10 mm
RUDDER (R&L)	32 mm	32 mm	22 mm	22 mm
FLAP		11 mm		

Recommended Control Surface Throws				
DEGREES	HIGH RATE		LOW RATE	
	Up	Down	Up	Down
ELEVATOR	10°	10°	8°	8°
AILERONS	20°	20°	14°	14°
RUDDER (R&L)	26°	26°	18°	18°
FLAP		34°		

Check the C.G.

Same as the control throws, the C.G. has a great effect on how every model flies, so do not skip this procedure. If the model is tail-heavy it may be too instable and respond too quickly to the controls. If the model is nose-heavy it may be too stable and not respond fast enough—in either case possibly causing a crash. Do not overlook this important procedure.

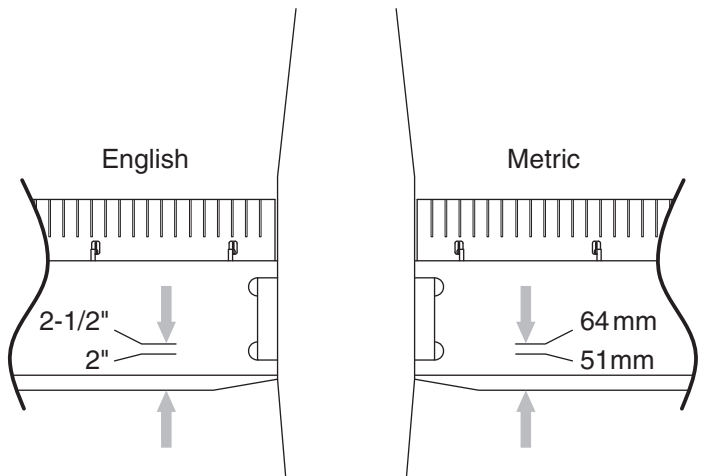

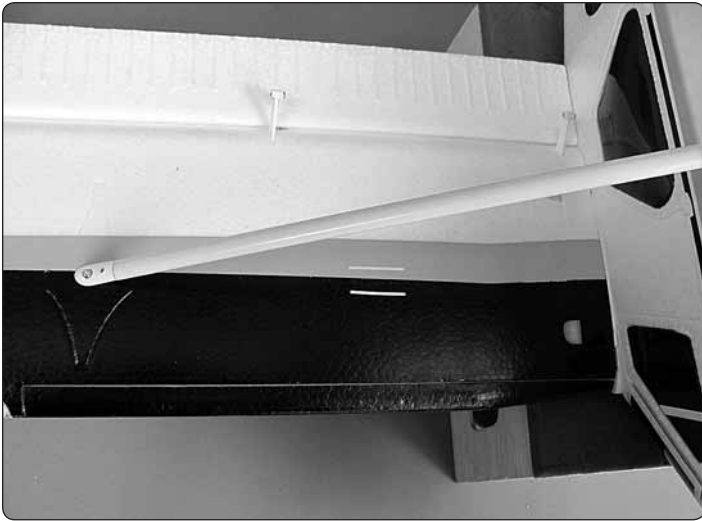

❑ 1. Mark the **forward** and **aft** C.G. limits on both sides of the bottom of the wing 2" and 2-1/2" [51mm and 64mm] back from the leading edge where shown—using narrow strips of tape will allow you to feel the marks when lifting the model with your fingertips to balance.



❑ 2. Mount the propeller and spinner.

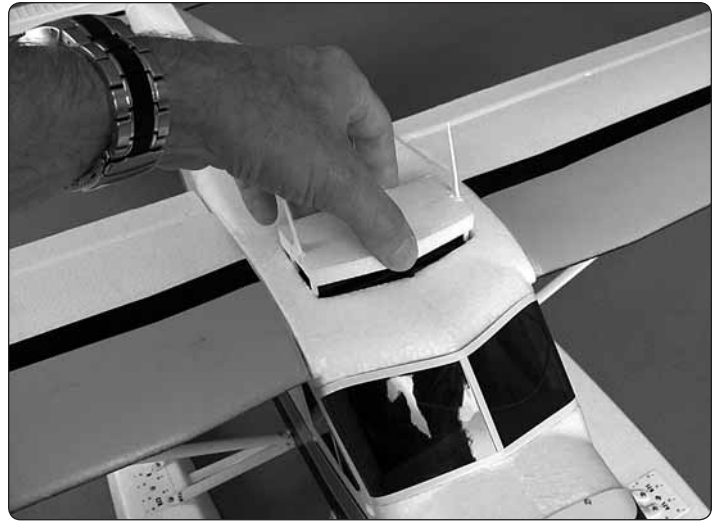

❑ 3. Install the battery, battery hatch and cabin hatch. At this point the Beaver must be in ready-to-fly condition with everything attached and installed including the floats or wheels and battery and propeller.



❑ 4. Lift the model by your fingers between the lines indicating the balance range. As long as the Beaver sits level with your fingers on the **forward** or **aft** lines or anywhere **between** the lines it is properly balanced and ready to fly. If you have to move your fingertips outside the lines the Beaver is out of balance and should not be flown. If necessary, add squares of stick-on lead to the nose or tail to get the Beaver to balance within the specified range.

MOTOR SAFETY PRECAUTIONS

Failure to follow these safety precautions may result in severe injury to yourself and others.

- Seek the assistance of an experienced pilot if new to electric motors.
- Wear safety glasses whenever in the proximity of a spinning propeller.
- Do not operate the motor in an area of loose gravel or sand; the propeller may throw such material in your face or eyes.
- Keep spectators as well as your own face and body out of the plane of rotation of the propeller.

- Keep all loose clothing, long hair or any other loose objects such as pencils or screwdrivers that may fall out pockets away from the propeller.

MOTOR / ESC OPERATION

Turning on the transmitter and running the motor is intuitive for most pilots who already have experience with electric motors, but for those who may have little or no experience with electric motors here are basic operating instructions for the ESC and motor:

When ready to fly and running the motor, **first** turn on the transmitter and make sure the throttle stick is all the way down. Always securely hold onto the model when connecting the battery. The propeller should not turn, but expecting it to do so anyway will prevent an accident or injury. Connect the battery to the ESC. The ESC will send three short electrical pulses to the motor, causing it to chime three times (“♪1-2-3”) followed by a longer, single, lower tone beep (“BEEEP”), followed by a shorter, higher tone beep (“beep”). The model is ready to fly and the propeller will turn when the throttle is advanced.

If the transmitter is **not** turned on before the battery and ESC are connected (so the receiver is not receiving a signal) the motor will still chime three times (“♪1-2-3”), but then it will sound consecutive, higher tone beeps (“beep,” “beep,” “beep,”...) until the transmitter is turned on at which time it will emit a single, lower tone beep (“BEEEP”) followed by the single higher tone beep (“beep”).

If, when the battery is connected to the ESC the throttle stick is not all the way down the motor will beep rapidly (“beep beep beep beep beep...”) until either the battery is disconnected or the throttle stick is returned to the off position at which time it will emit a single, lower tone beep (“BEEEP”) followed by the single higher tone beep (“beep”).

FLYING

The Beaver flies mostly the same as any similar-type, high-wing airplane, but you may find that the roll rate is a little slower. This suits the Beaver well as it is a scale-like, STOL (Short TakeOff and Landing) craft. Just give yourself more time and altitude before trying your first full roll.

The only peculiarity arises when the flaps are extended—if you extend the flaps too soon before the Beaver has lost enough flying speed the nose will pitch up. The way to avoid this is first by making sure you have given the Beaver enough time to slow after cutting the throttle. You can also roll in the flaps gradually. If you have a computer radio you could also mix in some down elevator with flaps. In any regard, once the Beaver reaches “equilibrium” and has initiated a gliding descent the nose will resume a normal, downward glide angle. Similarly, when powering up the throttle with the flaps extended the nose will pitch up, so be ready to counter with down elevator.

Taken verbatim from our flight log book... “Flying the Beaver from water with floats can be described with many adjectives including *astounding*, *easy*, *fun*, *smooth*, *remarkable*, etc.”

Unless weather conditions are terrible, you should have no trouble flying the Beaver from either rough or calm water. The water rudders direct the Beaver well and they don't have to be perfectly centered to be effective (so don't spend an exorbitant amount of time on the work bench working on them!). The Beaver turns more tightly at idle speeds, so if you need to do a U-turn throttle back to bring the Beaver around. At higher speeds during a takeoff run the water rudders have the correct amount of effectiveness to steer the Beaver on its intended path. Takeoffs can be long and graceful or short and steep—either way the floats handle the water well. If the winds are really high the Beaver can still be flown from water, but avoid turning it directly across the wind. Otherwise, the wind can get under the wing and flip the Beaver over. In the air, the only effect of the floats is that the Beaver flies slightly slower.

Flying “normally” (using half-throttle for general cruising and full-throttle only when required) the Beaver consumes about 200mAh/minute for recommended flight times of about 7 minutes with an 1800 mAh battery and about 8.5 minutes with a 2100mAh battery. Flying more aggressively using higher throttle settings, the current draw increases closer to 260mAh/minute for recommended flight times of 5.5 minutes with an 1800 mAh battery and 6.5 minutes with a 2100mAh battery.

To find out for yourself how long you can fly, set your timer to a conservative 5 minutes. Fly until the timer sounds, then land. Use a charger with a digital display to find out how much capacity it took to recharge the battery (indicating how much capacity was used). To avoid over discharging your LiPos use only 80% of your battery's capacity, so multiply your battery's capacity by .8 to find out how much you have available. Compare the capacity used to 80% of your battery's capacity and adjust your flight time accordingly.

For example: If using the recommended 1800mAh battery, your target capacity to use for a flight is 1440mAh (1800mAh x .8 = 1440mAh). If you fly for five minutes and it takes 1000mAh to recharge your battery, you still have 440mAh to go before you should land, so adjust your timer to increase your flight time accordingly until you reach your 1440mAh target. (You could also divide 1000mAh by five minutes to figure a current consumption rate of 200mAh/minute. Divide 1440mAh by 200mAh/minute to conclude that you can fly for 7.2 minutes [7 min. 12 sec.]—but round down to 7 minutes.)



It's also a great idea to use a LiPo battery checker (HCAP0275) to check the battery **before** each flight (to make sure you haven't inadvertently grabbed a discharged battery) and to check the battery **after** flight to make sure you haven't over discharged your battery by flying too long. A safe, conservative, minimum voltage is 3.65V – 3.7V per cell right after a flight.

REPAIRS

Parts damaged beyond repair can be purchased separately. The full replacement part list is printed in the front of the manual on page 4. Often though, parts can be repaired and you can get your Beaver back into the air with a little glue and ingenuity.

The Beaver is made from injection-molded EPO (expanded polyolefin) foam which can be glued with just about anything. Most people use regular CA. With CA no clamping is required, but some prefer softer, more flexible adhesives such as white glue or canopy glue. These will require clamps or tape to hold the parts together while the glue dries.

One final note about flying your model. Have a goal or flight plan in mind for **every** flight. This can be learning a new maneuver(s), improving a maneuver(s) you already know, or learning how the model behaves in certain conditions (such as on high or low rates). This is not necessarily to improve your skills (*though it is never a bad idea!*), but more importantly so you do not surprise yourself by impulsively attempting a maneuver and suddenly finding that you've run out of time, altitude or airspeed. Every maneuver should be deliberate, not impulsive. For example, if you're going to do a loop, check your altitude, mind the wind direction (anticipating rudder corrections that will be required to maintain heading), remember to throttle back at the top, and make certain you are on the desired rates (high/low rates). A flight plan greatly reduces the chances of crashing your model just because of poor planning and impulsive moves. **Remember to think.**

Have a ball! But always stay in control and fly in a safe manner.

GOOD LUCK AND GREAT FLYING!

This model belongs to:

Name
Address
City, State, Zip
Phone Number
AMA Number