

Operation Guide

Before first use, please carry out the initial operation procedure as per the operating instructions (see “**Prior to initial use**” section for full details). This guide does not replace the description in the operating instructions. Before you start, read and follow the “**safety**” chapter and observe the “**Appliance parts**” chapter. The user manual also contain further tips about correct **handling, cleaning and descaling**, as well as a “**Faults and rectification**” section.

Pre-heating

Before brewing espresso each time, we recommend rinsing through the brewing unit once with hot water, together with the filter holder and the respective filter, and pre-heating the cup(s).

- Press the ON/OFF button and let the machine heat up.
- Place the espresso cup(s) under the filter holder and press the button of single espresso.
- Carefully pour out the remaining water in the filter and wipe the filter dry.

Setting the grind size

The grind size will affect the rate of water flow through the coffee in the filter basket and the flavor of the espresso. When setting the grind size, it should be fine, but not too fine.

The grind size selector has 15 grind settings. The smaller the number, the finer the grind size; the larger the number, the coarser the grind size.

We recommend you start at setting 8-10 and adjust as required. Different espresso beans will most likely require different settings.

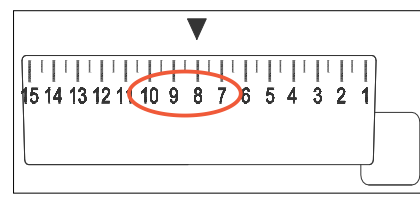

We do not recommend that you select grind levels 1-3 initially. They are too fine when the machine is new and will become more suitable with prolonged use of the machine.

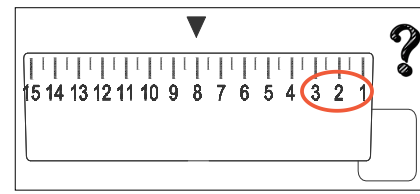

1

High pressure zone

When the gauge needle is in the 12-20 zone during extraction, this indicates the espresso has been extracted with too much pressure.

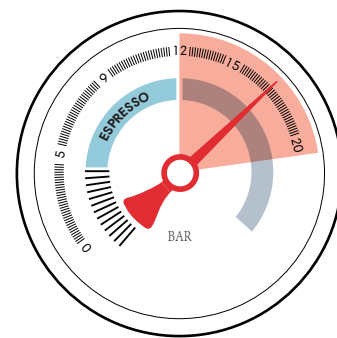

This can happen when the water flow through the ground coffee is too slow and results in an over extracted espresso that is very dark and bitter with a mottled and uneven crema. Possible causes for over extraction include: the grind being too fine, too much ground coffee in the filter, over tamping or a combination of any of these.

To resolve this:

- Select a coarser grind setting and retry.
- Decrease the amount of coffee grounds and retry.
- Decrease the tamping pressure and retry.

	Grind Level	Amount of Coffee	Tamping Pressure	Extraction Time
Over extraction (12-20 bar)	Too Fine	Too Much	Too Heavy	Over 40 seconds
Ideal extraction (5-12 bar)	Optimal	11-13g for 1 CUP 18-21g for 2 CUP	11-22lbs (5-10kg)	20-30 seconds for 1 CUP 25-35 seconds for 2 CUP
Under extraction (0-5 bar)	Too Coarse	Too Little	Too Light	Under 20 seconds

5

Selecting the filter size

Insert either the 1 CUP size filter or 2 CUP size filter into the filter holder. Select the 1 CUP size filter if you want to make a single espresso and 2 CUP size filter if you want to make a double.

We recommend the grinding amount as below:
11-13 g for a single espresso
18-21 g for a double espresso

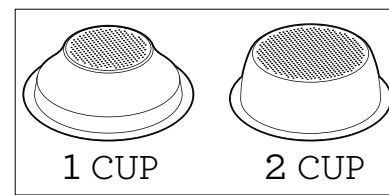

We also recommend the grinding time as below:

The grinding time for different settings

Type of Espresso Filter	Grinder Size		
	Setting at 8	Setting at 9	Setting at 10
Single Espresso Filter	13 seconds	12 seconds	11 seconds
Double Espresso Filter	19 seconds	17 seconds	15 seconds

Note: The grinding time will vary depending on the coffee bean you used. You may need to experiment with how long the grinder needs to run to achieve the correct dose.

Grinding the coffee beans

Insert the filter holder into the bracket, push and hold the filter holder to engage the grinding activation switch. Continue holding until the desired amount of ground coffee has been dosed.

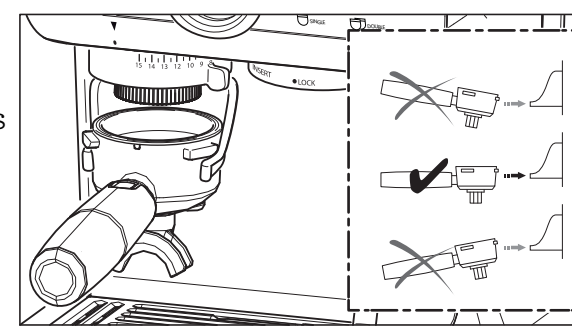

To stop grinding, release the filter holder. This will release the grinding activation switch and stop the grinding function.

2

Preparing the milk

Position the steam wand tip over the drip tray.

Turn the STEAM regulator to the PREHEAT position. The indicator will flash to indicate the machine is heating up to create steam. During this time, fluid may drip from the steam wand. This is normal.

When the STEAM indicator stops flashing, the steam wand is ready for use.

Insert the tip of the steam wand 1-2mm below the surface of the milk, close to right hand side of the jug at the 3 o'clock position and quickly turn the regular to STEAM position.

Keep the tip just under the surface of the milk until the milk is spinning clockwise, producing a vortex.

With the milk spinning, slowly lower the jug. This will bring the steam tip to the surface of the milk and start to introduce the air into the milk. You may have to gently break the surface of the milk with the tip to get the milk spinning fast enough.

Keep the tip at or slightly below the surface, maintaining the vortex. Continue to texture the milk until it's at the desired volume.

Now lift the jug so that the tip is lowered beneath the surface of the milk, but keep the milk spinning. The milk will be at the correct temperature (140-149°F or 60-65°C) when the jug is hot to the touch, but not scalding.

Turn the regular to the OFF position before removing the steam wand from the milk.

Set the jug to one side and immediately wipe the steam wand clean with a damp cloth. Then, with the steam wand tip directly over the drip tray, briefly turn the steam on to clear any remaining milk from inside the steam wand.

6

Note: You may need to experiment with how much coffee is inserted into the filter basket or how long the grinder needs to run to achieve the correct dose.

Tamping the coffee grounds

Tap the filter holder several times to collapse and distribute the coffee grounds evenly in the filter.

Tamp down firmly using approx. 11-22lbs (5-10kg) of pressure.

The amount of pressure is not as important as ensuring that consistent pressure is applied.

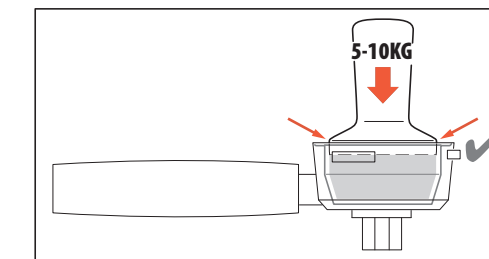

As a guide to using the right amount of coffee grounds, the top edge of the metal cap on the tamper should be level with the top of the filter after the coffee has been tamped.

Making espresso

Ensure the steam volume regulator is switched to the OFF position before making espresso.

Press the 1 CUP button to make a single espresso or the 2 CUP button to make a double espresso.

Volume of 1 CUP espresso: approx. 1-1.5oz (30-50ml)
Volume of 2 CUP espresso: approx. 2-2.5oz (55-85ml)

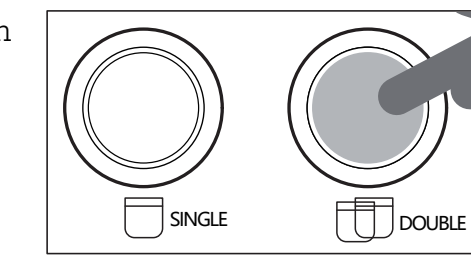

Note: The amount of espresso extracted into the cup will vary depending on your grind size, amount of coffee used, and tamping pressure.

Note: While the machine is making espresso, a pumping noise can be heard. This is normal operation of the 20 bar Italian pump.

3

Tap the jug on the bench to collapse any bubbles

Swirl the jug to refine and re-integrate the texture.

Pour the milk directly into the espresso.

The key is to work quickly, before the milk begins to separate.

Note: Always use fresh cold milk only.

Note: When frothing milk, the steam wand tip will make a lot of noise. This is normal. The noise will disappear when the milk is almost ready.

Making hot water

When the machine is on STANDBY mode, press the HOT WATER button. Hot water will pour out from the steam wand and can be used for making Americanos and/or pre-heating cups.

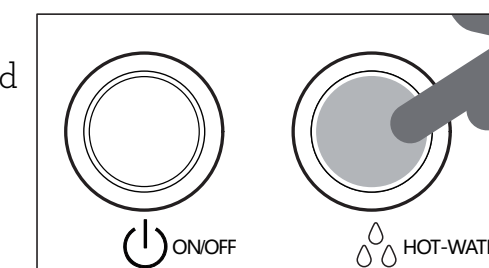

To stop the hot water, just press the HOT WATER button again.

7

Espresso Pressure Gauge

Ideal Espresso Zone

The gauge needle indicates the extraction pressure. When it is positioned anywhere within 5-12 zone during extraction, it means the espresso has been extracted at the ideal pressure.

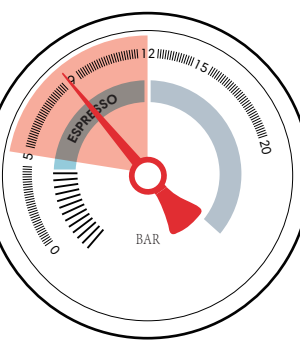

Low pressure zone

When the gauge needle is in the 0-5 zone during extraction, this indicates the espresso has been extracted with insufficient pressure.

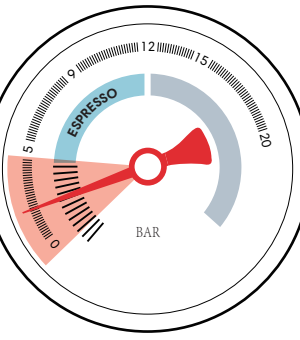

This can happen when the water flow through the ground coffee is too fast, resulting in an under extracted espresso that is watery and lacks crema and flavor. Possible causes for under extraction include: the grind being too coarse, insufficient coffee in the filter, insufficient tamping, or a combination of any of these.

To resolve this:

- Select a finer grind setting and retry.
- Increase the amount of coffee grounds and retry.
- Increase the tamping pressure and retry.

Cleaning the grinder

The grinder must be removed from the espresso machine for cleaning.

01. Remove the coffee bean container in an anti-clockwise and upward motion.

02. Press the release button (red button below the symbol ) and turn the grinding mechanism anti-clockwise to release it via the engagement position, and pull it out in a downward motion.

03. Turn the grinder upside-down and rotate the coffee distributor clockwise() , to release it from the grinder via the locking position and remove it.

04. Clean all accessible parts of the grinder and the coffee distributor carefully using the cleaning brush.

05. Set the coffee distributor on the grinder and turn it anti-clockwise() to lock it in via the engagement position.

Note: The grinder system cannot be operated without the coffee distributor.

06. Re-insert the grinder as follows:

- Hold the grinder and turn the degree of grinding pre-selection against the grinding mechanism as shown, as far as it will go.

- Insert the grinder into the espresso machine as illustrated.

- Now, turn the grinding mechanism clockwise (seen from the top) to let it engage. Once the grinder is assembled correctly, you can hear a sound and feel resistance.

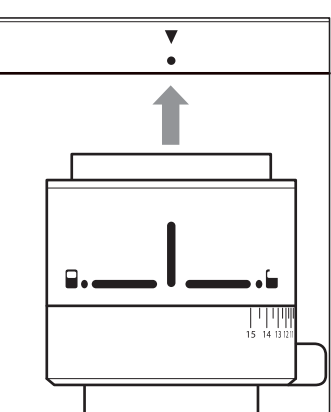

07. Insert the coffee bean container.

8