



**Fosi Audio**

## **User's Manual**

Fosi Audio Bluetooth Power Amplifier Board

# Contents

<b>Description</b>	01
<b>Quick steup for ZK-1002L/ZK-502L</b>	01
<b>Quick steup for ZK-1002/ ZK-502C/ ZK-502T/ ZK-1002T</b>	02
<b>Quick steup for ZK-TB21</b>	03
<b>ZK1002</b>	04
Introduction/ Product Parameters/ Package Includes	04
Product Overview/ Installation	05
<b>ZK1002L</b>	06
Introduction/ Product Parameters/ Package Includes	06
Product Overview/ Installation	07
<b>ZK-502C</b>	08
Introduction/ Product Parameters/ Package Includes	08
Product Overview/ Installation	09
<b>ZK-502L</b>	10
Introduction/ Product Parameters/ Package Includes	10
Product Overview/ Installation	11
<b>ZK-502T</b>	12
Introduction/ Product Parameters/ Package Includes	12
Product Overview/ Installation	13
<b>ZK-1002T</b>	14
Introduction/ Product Parameters/ Package Includes	14
Product Overview/ Installation	15
<b>ZK-TB21</b>	16
Introduction/ Product Parameters/ Package Includes	16
Product Overview/ Installation	17
<b>How to connect the speaker?</b>	17
<b>Note</b>	17
<b>Q&amp;A</b>	18
<b>Warranty Information</b>	19
Comparison	20

# Fosi Audio Bluetooth Power Amplifier Board

## ZK-1002 /ZK-1002L /ZK-502C /ZK-502L /ZK-502T/ZK-1002T/ZK-TB21

### User Guide

## Description

This manual contains the introduction, installation instructions, and usage methods of five Fosi Audio Bluetooth amplifier boards. Please note that the product model you purchase needs to correspond to this part of the manual. If you have any questions about how to use it, please feel free to contact us.

These Fosi Audio HIFI audio amplifier boards are high-power stereo audio modules with filtering capabilities. 2 CH output and the built-in amplifier module, so it can be directly connected to passive speakers as an amplifier. Also, it is ideal for DIY wireless speakers and transponders.

## Quick step for ZK-1002L/ZK-502L

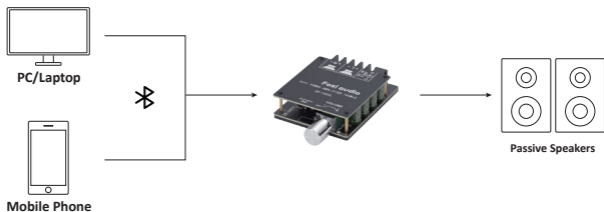

### Bluetooth Connection

Bluetooth 5.0

Speakers Output

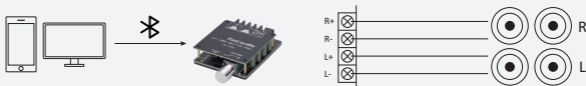

## Quick stepup for ZK-1002/ ZK-502C/ ZK-502T/ZK-1002T

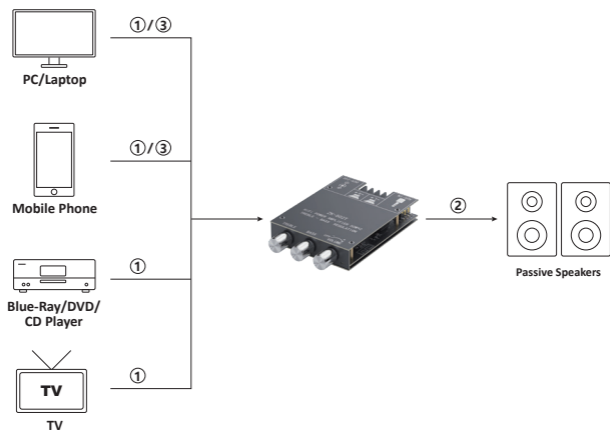

### Audio Connection

#### ① 3.5MM AUX Input



#### ② Speakers Output



### Bluetooth Connection

#### ③ Bluetooth 5.0



#### ② Speakers Output



## Quick stepup for ZK-TB21

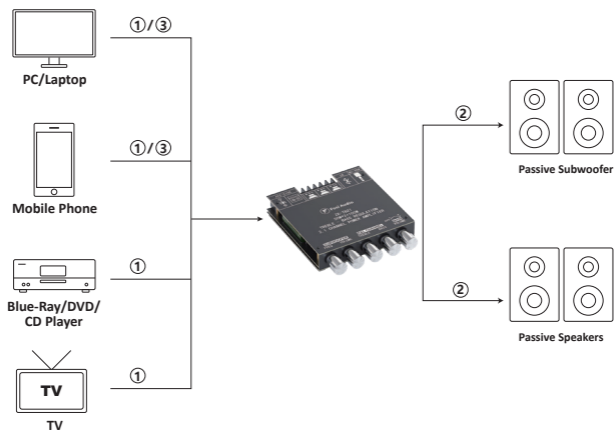

### Audio Connection

#### ① 3.5MM AUX Input

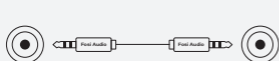

#### ② Speakers Output



### Bluetooth Connection

#### ③ Bluetooth 5.0



#### ② Speakers Output



## ZK-1002

### Introduction

ZK-1002 Bluetooth 5.0 2 Channel Stereo Amplifier Board has a maximum output of 100watt per channel. Use two TPA3116D2 chips to bring you great HIFI stereo sound quality. With two input methods, you can connect using Bluetooth or 3.5MM audio cable. Suitable for 40hm-80hm, 50watt-300watt 2 channel passive speakers.

### Product Parameters

Model: ZK-1002  
Chip: TPA3116D2\*2  
Input Mode: Bluetooth and 3.5mm AUX  
Work Voltage: DC 5V-27V (Above 2A)  
Channel: 2 CH Stereo Output  
Bluetooth version: Bluetooth 5.0  
Bluetooth transmission distance: 50 Ft  
MAX Power Output: 100W x 2  
Terminating Impedance: 4 Ohm-8 Ohm  
Match Speaker: 50watt-300watt  
Work Temperature:-40°C~85°C  
Work Humidity:0%~95%RH  
Size: 3.3 \* 2 \* 0.95 inch  
Weight: 0.28lb/130g  
DC socket: 5.5\*2.1mm

### Package Includes:

- 1: ZK-1002 Stereo Bluetooth Power Amplifier Module \* 1
- 2: Acrylic shell \* 2
- 3: 16mm Copper column \* 4
- 4: 9mm Screw \* 8
- 5: Steel nut, screw mat \* 1
- 6: 20cm power cable \* 1
- 7: Screwdriver \* 1
- 8: Knob \* 1

## Product Overview

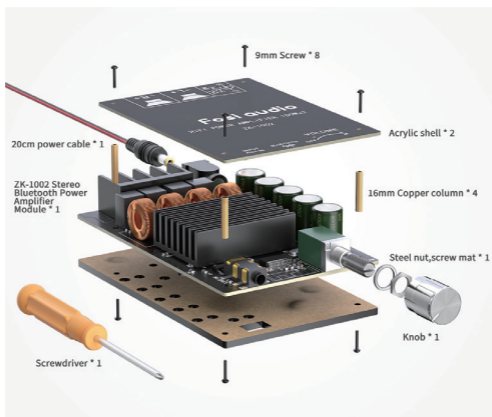

## Installation

**Step1-** Install the bottom acrylic shell

Use the screwdriver to install the bottom 4 counts 9mm screw to connect the copper column, amplifier board, and bottom acrylic shell.

**Step2-** Install the top acrylic shell

Use the screwdriver to install the top 4 counts 9mm screw to connect the copper column and the top acrylic shell

**Step3-** Install steel nut, screw mat, and knob.

1: Install the steel nut;

2: Install the screw mat;

3: Install the volume knob

Adjust the volume switch in the OFF position.

Then insert the volume knob until it fits perfectly with the steel nut.

Note: There is a volume mark, you need to put the volume mark in the six o'clock position to insert the volume knob.

## ZK-1002L

### Introduction

ZK-1002L Bluetooth 5.0 2 Channel Stereo Amplifier Board has a maximum output of 100watt per channel. Suitable for 40hm-80hm, 50watt-300watt 2 channel passive speakers.

### Product Parameters

Model: ZK-1002L

Input Mode: Bluetooth

Work Voltage: DC 5V-24V (Above 2A)

Channel: 2 CH Stereo Output

Bluetooth version: Bluetooth 5.0

Bluetooth transmission distance: 50 Ft

MAX Power Output: 100W x 2

Terminating Impedance: 4 Ohm-8 Ohm

Match Speaker: 50watt-300watt

Work Temperature:-40°C~85°C

Work Humidity:0%~95%RH

Size: 2.68 \* 2.05 \* 0.83 inch

Weight: 0.26lb/120g

DC socket: 5.5\*2.1mm

### Product Overview

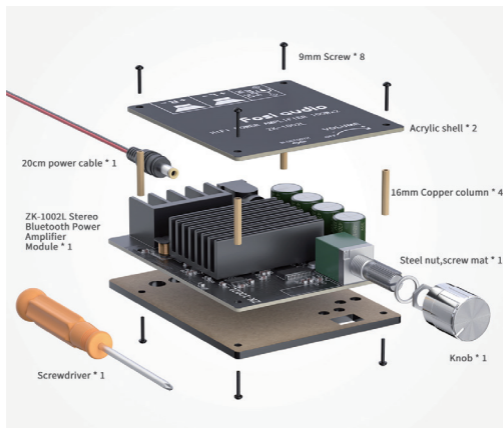

## Package Parameter:

- 1: ZK-1002L Stereo Bluetooth Power Amplifier Module \* 1
- 2: Acrylic shell \* 2
- 3: 16mm Copper column \* 4
- 4: 9mm Screw \* 8
- 5: Steel nut, screw mat \* 1
- 6: 20cm power cable \* 1
- 7: Screwdriver \* 1
- 8: Knob \* 1

## Installation

### **Step1-** Install the bottom acrylic shell

Use the screwdriver to install the bottom 4 counts 9mm screw to connect the copper column, amplifier board, and bottom acrylic shell.

### **Step2 -** Install the top acrylic shell

Use the screwdriver to install the top 4 counts 9mm screw to connect the copper column and the top acrylic shell.

### **Step3-** Install steel nut, screw mat, and knob

- 1: Install the steel nut;
- 2: Install the screw mat;
- 3: Install the volume knob:

Adjust the volume switch in the OFF position.

Then insert the volume knob until it fits perfectly with the steel nut.

Note: There is a volume mark, you need to put the volume mark in the six o'clock

## ZK-502C

### Introduction

ZK-502C Bluetooth 5.0 2 Channel Stereo Amplifier Board has a maximum output of 50watt per channel. Use TPA3116D2 chip to bring you great HIFI stereo sound quality. With two input methods, you can connect using Bluetooth or 3.5MM audio cable. Suitable for 40hm-80hm, 50watt-200watt 2 channel passive speakers.

### Product Parameters

Model: ZK-502C  
Input Mode: Bluetooth, AUX  
Work Voltage: DC 5V-27V(Above 2A)  
Channel: 2 CH Stereo Output  
Bluetooth version: Bluetooth 5.0  
Bluetooth transmission distance: 50 Ft  
MAX Power Output: 50W x 2  
Terminating Impedance: 4 Ohm-8 Ohm  
Match Speaker: 30watt-200watt  
Work Temperature:-40°C~85°C  
Work Humidity:0%~95%RH  
Size: 3.2 \* 1.98 \* 0.72 inch  
Weight: 0.24lb/111g  
DC socket: 5.5\*2.1mm

### Product Overview

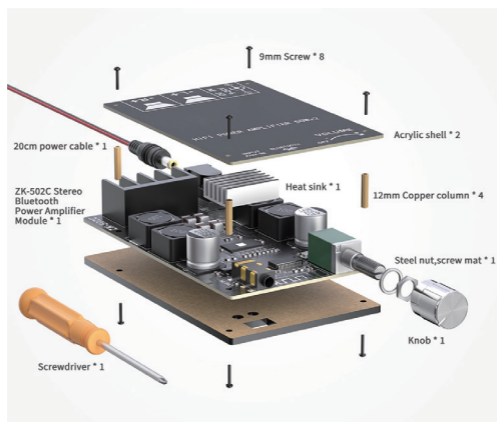

## Product Parameters

- 1: ZK-502C Stereo Bluetooth Power Amplifier Module \* 1
- 2: Acrylic shell \* 2
- 3: 12mm Copper column \* 4
- 4: 9mm Screw \* 8
- 5: Steel nut, screw mat \* 1
- 6: 20cm power cable \* 1
- 7: Screwdriver \* 1
- 8: Knob \* 1
- 9: Heat sink \* 1

## Installation

**Step1-** Install the bottom acrylic shell

Use the screwdriver to install the bottom 4 counts 9mm screw to connect the copper column, amplifier board, and bottom acrylic shell.

**Step2-** Install the heat sink

Paste the heat sink to the chip position of the Bluetooth amplifier board.

**Step3** - Install the top acrylic shell

Use the screwdriver to install the top 4 counts 9mm screw to connect the copper column and the top acrylic shell.

**Step4-** Install steel nut, screw mat, and knob

- 1: Install the steel nut;
- 2: Install the screw mat;
- 3: Install the volume knob:

Adjust the volume switch in the OFF position.

Then insert the volume knob until it fits perfectly with the steel nut.

Note: There is a volume mark, you need to put the volume mark in the six o'clock position to insert the volume knob.

## ZK-502L

### Introduction

ZK-502L Bluetooth 5.0 2 Channel Stereo Amplifier Board has a maximum output of 50watt per channel. Suitable for 40hm-80hm, 50watt-200watt 2 channel passive speakers.

### Product Parameters

Model: ZK-502L

Input Mode: Bluetooth

Work Voltage: DC 5V-24V(Above 2A)

Channel: 2 CH Stereo Output

Bluetooth version: Bluetooth 5.0

Bluetooth transmission distance: 50 Ft

MAX Power Output: 50W x 2

Terminating Impedance: 4 Ohm-8 Ohm

Match Speaker: 30watt-200watt

Work Temperature:-40°C~85°C

Work Humidity:0%~95%RH

Size: 2.17 \* 1.5 \* 0.67 inch

Weight: 0.11lb / 52g

DC socket: 5.5\*2.1mm

### Product Overview

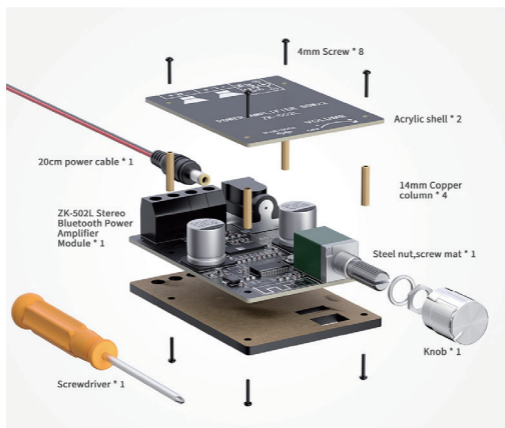

## Package Contents

- 1: ZK-502L Stereo Bluetooth Power Amplifier Module \* 1
- 2: Acrylic shell \* 2
- 3: 14mm Copper column \* 4
- 4: 8mm Screw \* 8
- 5: Steel nut, screw mat \* 1
- 6: 20cm power cable \* 1
- 7: Screwdriver \* 1
- 8: Knob \* 1

## Installation

**Step1-** Install the bottom acrylic shell

Use the screwdriver to install the bottom 4 counts 4mm screw to connect the copper column, amplifier board, and bottom acrylic shell.

**Step2 -** Install the top acrylic shell

Use the screwdriver to install the top 4 counts 4mm screw to connect the copper column and the top acrylic shell.

**Step3 -** Install steel nut, screw mat, and knob

1: Install the steel nut;

2: Install the screw mat;

3: Install the volume knob:

Adjust the volume switch in the OFF position.

Then insert the volume knob until it fits perfectly with the steel nut.

Note: There is a volume mark, you need to put the volume mark in the six o'clock position to insert the volume knob.

## Introduction

ZK-502T Bluetooth 5.0 2 Channel Stereo Amplifier Board has a maximum output of 50watt per channel. Use TPA3116D2 chip to bring you great HIFI stereo sound quality. With two input methods and bass and treble control, you can connect using Bluetooth or 3.5MM audio cable. Suitable for 40Ohm-80hm, 50watt-200watt 2 channel passive speakers.

## Product Parameters

Model: ZK-502T

Input Mode: Bluetooth, AUX

Work Voltage: DC 5V-24V(Above 2A)

Channel: 2 CH Stereo Output

Bluetooth version: Bluetooth 5.0

Bluetooth transmission distance: 50 Ft

MAX Power Output: 50W x 2

Treble and bass control: Yes

Terminating Impedance: 4 Ohm-8 Ohm

Match Speaker: 15watt-100watt

Work Temperature:-40°C~85°C

Work Humidity:0%~95%RH

Size: 3.7\*2.76\*0.83 inch

Weight: 0.34lb/154g

DC socket: 5.5\*2.1mm

## Product Overview

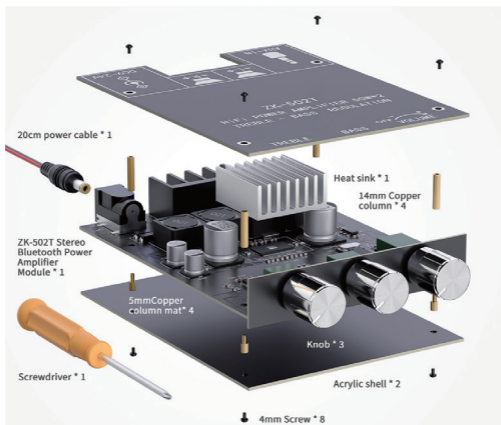

## Package Contents

- 1: ZK-502T Stereo Bluetooth Power Amplifier Module \* 1
- 2: Acrylic shell \* 2
- 3: 14mm Copper column \* 4
- 4: 5mm Copper column mat\* 4
- 5: 4mm Screw \* 8
- 6: 20cm power cable \* 1
- 7: Screwdriver \* 1
- 8: Knob \* 3
- 9: Heat sink \* 1

## Installation

**Step1-** Install the bottom acrylic shell

Use the screwdriver to install the bottom 4 counts 4mm screw to connect the copper column, copper column mat, amplifier board, and bottom acrylic shell.

**Step2** - Install the heat sink

Paste the heat sink to the chip position of the Bluetooth amplifier board.

**Step3** - Install the top acrylic shell

Use the screwdriver to install the top 4 counts 4mm screw to connect the copper column and the top acrylic shell.

**Step4-** Install the knob

Adjust the volume switch to the OFF position. Turn the treble control and bass control switch to the right until the gain is minimal.

Then insert the knob until it completely fits the front panel.

Note: All three knobs have a volume mark, you need to place the mark at the six o'clock position of the knob and then insert the knob.

## Introduction

ZK-1002T Bluetooth 5.0 2 Channel Stereo Amplifier Board has a maximum output of 100watt per channel. Use TPA3116D2 chip to bring you great HIFI stereo sound quality. With two input methods and bass and treble control, you can connect using Bluetooth or a 3.5MM audio cable. Suitable for 40hm-80hm. 50watt-200watt 2 channel passive speakers.

## Product Parameters

Model: ZK-1002T

Input Mode: Bluetooth, AUX

Work Voltage: DC 5V-24V

Channel: 2 CH Stereo Output

Bluetooth version: Bluetooth 5.0

Bluetooth transmission distance: 50 Ft

MAX Power Output: 100Wx2

Treble and bass control: Yes

Terminating Impedance: 4 Ohm-8 Ohm

Match Speaker: 50watt-300wat

Work Temperature:-40℃~85℃

Work Humidity: 0%~95%RH

Size: 2.76\*3.70\*0.83 inch

Weight: 0.37lb/170g

DC socket: 5.5 2.1mm

## Product Overview

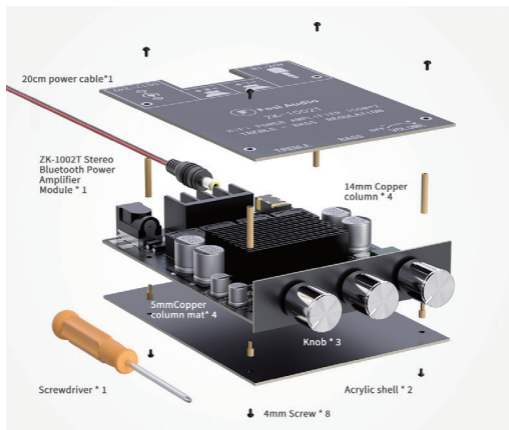

## Package Contents

- 1 : ZK-1002T Stereo Bluetooth Power Amplifier Module \* 1
- 2 : Acrylic shell \* 2
- 3 : 14mm Copper column \* 4
- 4 : 5mm Copper column mat \* 4
- 5 : 4mm Screw \* 8
- 6 : Screwdriver \* 1
- 7 : Knob \* 3
- 8 : 20cm power cable \* 1

## Installation

**Step1-** Install the bottom acrylic shell

Use the screwdriver to install the bottom 4 counts 4mm screw to connect the copper column, copper column mat, amplifier board, and bottom acrylic shell.

**Step2** - Install the heat sink

Paste the heat sink to the chip position of the Bluetooth amplifier board.

**Step3** - Install the top acrylic shell

Use the screwdriver to install the top 4 counts 4mm screw to connect the copper column and the top acrylic shell.

**Step4-** Install the knob

Adjust the volume switch to the OFF position. Turn the treble control and bass control switch to the right until the gain is minimal.

Then insert the knob until it completely fits the front panel.

Note: All three knobs have a volume mark, you need to place the mark at the six o'clock position of the knob and then insert the knob.

## Introduction

ZK-TB21 Bluetooth 5.0 2.1 Channel Stereo Subwoofer Amplifier Board has a maximum output of 50watt per channel. Use TPA3116D2 chip to bring you great HIFI stereo sound quality. With two input methods and bass and treble control, you can connect using Bluetooth or a 3. 5MM audio cable. Suitable for 40hm-80hm. 50watt-200watt 2.1 channel passive speakers or subwoofer.

## Product Specifications

Model: ZK-TB21

Input Mode: Bluetooth, AUX

Work Voltage: DC 12V-24V

Channel: 2.1 CH Stereo Output

Bluetooth version: Bluetooth 5.0

Bluetooth transmission distance: 50 Ft

MAX Power Output: 50W\*2 (R&L) +100W (Subwoofer)

Treble and bass control: Yes

Terminating Impedance: 4 Ohm-8 Ohm

Match Speaker: 50watt-300wat

Work Temperature:-40℃~85℃

Work Humidity: 0%~95%RH

Size: 3.94\*3.94\*0.9 inch

Weight: 0.46lb/210g

DC socket: 5.5 2.1mm

## Product

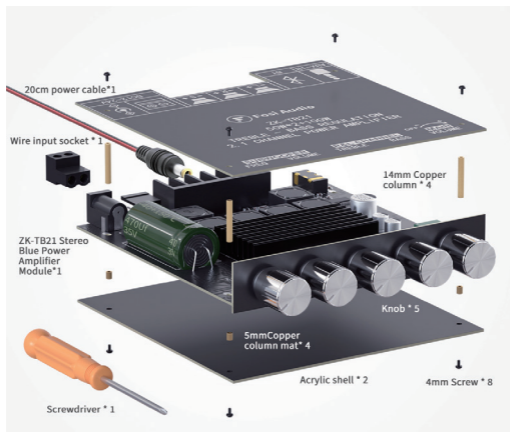

## Package Contents

- 1 : ZK-TB21 Stereo Bluetooth Power Amplifier Module \* 1
- 2 : Acrylic shell \* 2
- 3 : 14mm Copper column \* 4
- 4 : 5mm Copper column mat \* 4
- 5 : 4mm Screw \* 8
- 6 : Screwdriver \* 1
- 7 : Knob \* 5
- 8 : Wire input socket \* 1
- 9 : 20cm power cable \* 1

## Installation

**Step1-** Install the bottom acrylic shell

Use the screwdriver to install the bottom 4 counts 4mm screw to connect the copper column, copper column mat, amplifier board, and bottom acrylic shell.

**Step2 -** Install the heat sink

Paste the heat sink to the chip position of the Bluetooth amplifier board.

**Step3 -** Install the top acrylic shell

Use the screwdriver to install the top 4 counts 4mm screw to connect the copper column and the top acrylic shell.

**Step4-** Install the knob

Adjust the volume switch to the OFF position. Turn the treble control and bass control switch to the right until the gain is minimal.

Then insert the knob until it completely fits the front panel.

Note: All three knobs have a volume mark, you need to place the mark at the six o'clock position of the knob and then insert the knob.

## How to connect the speaker?

**Step1-**Use the screwdriver to loosen the speaker terminals on the amplifier.

**Step2-**Insert the speaker wires.

**Step3-**Install the screws to secure the speaker wires.

## Note:

Your home audio amplifier boards are not water-resistant, so it's important that they should be kept free of moisture. You should clean only with a dry cloth or tissue and no liquid cleaners or solvents should be used.

## Q&A

### 1. How to choose a power supply?

The power adapter for the amplifier board is important. Higher voltage and higher current will bring better output power. If you use a 12V 1A power adapter, the amplifier board can only drive 3-4in speakers. If you use a 19V 5A or higher voltage power adapter, then it can drive 8-10in speakers. We recommend using a good power adapter to work with this amplifier board.

**Note:** If the power supply voltage is low, the concert will be distorted after turning up the volume. If the current is low, it will not be able to drive your speakers, it may not work properly or the sound quality is not good. When this happens, please replace the larger power adapter.

We recommend using a power adapter higher than 3A for 100watt x 2. 50watt x 2 is recommended to use a power adapter higher than 2A.

### 2. How to choose a speaker?

Suitable for 4-80hm speakers. If your speaker power is 20watt-50watt, you can also use our power amplifier board, but the specification of the power adapter is preferably below 15V, in order to prevent the speaker from being burned after turning up the volume.

If your speaker power is 50watt-300watt, don't worry about anything. You can use a 19-24V power adapter, high voltage brings powerful output.

### 3. How to choose Bluetooth or AUX audio input mode?

Connect the power adapter, Bluetooth amplifier board and speakers. Turn on the switch of the power amplifier board, the blue indicator light is on. Turn the audio knob to nine o'clock. Use your phone's Bluetooth to search for "BT-WUZH1", there will be a beep when the connection is successful. The next time you use the Bluetooth amplifier board, it will automatically connect to your phone.

**Note:** Please ensure if there another device has paired with this amplifier board. This amplifier board can only be paired with one Bluetooth device at the same time. If another device has paired with it, your device can not pair with it.

If you use 3.5mm AUX input, you need to disconnect Bluetooth. After hearing the beep, insert the audio cable to play music. When using 3.5mm AUX input, if Bluetooth is connected, it will be converted to Bluetooth input.

#### **4. The sound quality decreases after turning up the volume.**

The power supply cannot drive the speaker. Please replace the power adapter with a higher voltage.

#### **5. The sound is not smooth after turning up the volume.**

The low current of the power adapter makes the intermittent power failure protection start. Please replace the power adapter with a higher current.

Or long-time high-power output, the power amplifier board is overheated, and the overheat protection of the power module is turned on. Turn down the volume or increase its heat dissipation.

## **About Fosi Audio**

Fosi Audio designs and builds innovative audio products with all your music in mind. Great sound, simple but elegant designs, high-quality materials, and truly useful features are what Fosi Audio is about. We sincerely hope you get as much enjoyment from our products as we've had to create them!

Our website: [www.fosiaudio.com](http://www.fosiaudio.com)

Amazon store: [www.amazon.com/fosiaudio](http://www.amazon.com/fosiaudio)

Our Youtube channel: Fosi Audio

Our Facebook page: Fosi Audio

Whatsapp: +86 17722625601

After-sale Service and Technical Support Email:

**[customer@fosiaudioshop.com](mailto:customer@fosiaudioshop.com)**

**[fosiaudio@hotmail.com](mailto:fosiaudio@hotmail.com)**

## **Warranty Information**

All Fosi Audio products have an 18-month limited warranty on parts and labor from the date of purchase. Please contact us if you have any problems.

### **What Is Covered?**

All defective parts or faulty workmanship.

### **What Is Not Covered?**

The warranty doesn't cover damage caused by accident, misuse, abuse, neglect, excessive moisture, lightning, power surges, other acts of nature, unauthorized product modification or repairs, or failure to follow the instructions outlined in this guide.

### What We Will Do?

We will repair or replace any defective parts, at our option, within a reasonable amount of time and free of charge any time during the warranty period.

### What We Ask From You?

You will be responsible for shipping charges to Fosi Audio or to an authorized dealer. We recommend and you keep the original shipping materials to prevent shipping damage if service is needed. Fosi Audio cannot be responsible for any damages incurred during shipping due to poor packing, so please pack well and make sure to insure your shipment.

## Comparison

Model	ZK-1002	ZK-1002L	ZK-502C	ZK-502L	ZK-502T	ZK-1002T	ZK-TB21
Channel	2.0CH	2.0CH	2.0CH	2.0CH	2.0CH	2.0CH	2.1CH
Max Output Power Per Channel	100 watt x2	100 watt x2	50 watt x2	50 watt x2	50 watt x2	100 watt x2	50wattx2+ 100 watt x2
Bass and Treble Control	No	No	No	No	Yes	Yes	Yes
Input ways	Bluetooth 5.0 3.5mm AUX	Bluetooth 5.0	Bluetooth 5.0 3.5mm AUX	Bluetooth 5.0	Bluetooth 5.0 3.5mm AUX	Bluetooth 5.0 3.5mm AUX	Bluetooth 5.0 3.5mm AUX
Work Voltage	DC 5V-27V	DC 5V-24V	DC 5V-27V	DC 5V-24V	DC 9V-24V	DC 5V-24V	DC 12V-24V
Size(inch)	3.3*2* 0.95	2.68*2.05* 0.83	3.2*1.98* 0.72	2.17*1.5* 0.72	3.94*3.94* 0.9	2.76*3.70* 0.83	3.94*3.94* 0.9

**Fosi audio**

[www.fosiaudio.com](http://www.fosiaudio.com)

Amazon store: [www.amazon.com/fosiaudio](http://www.amazon.com/fosiaudio)

Our Facebook page: Fosi Audio

Whatsapp: +86 17722625601

After-sale Service and Technical Support Email:

[customer@fosiaudioshop.com](mailto:customer@fosiaudioshop.com)

[fosiaudio@hotmail.com](mailto:fosiaudio@hotmail.com)

