

# Unboxing-Installation guide of the Rotary Roller Engraving Module Laserbox Rotary

## Overview:

- Part 1: List of items
- Part 2: Meet the Rotary Roller Engraving Module
- Part 3: Installing the Engraving Module in the Laserbox Rotary
- Part 4: Adjusting the position of the movable roller of the Engraving Module
- Part 5: Switching from the cylindrical to the 2D work mode
- Part 6: Suggestions on power and speed parameters for certain materials

## Part 1: List of items

The pack of the Rotary Roller Engraving Module comes with the following items:

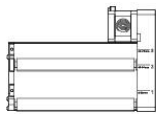

Rotary engraving module × 1



Connection cable × 2



Hex key × 1



User guide card × 1

## Part 2: Meet the Rotary Roller Engraving Module

This additional attachment is placed inside of the Laserbox Rotary to support the cylindrical objects to be engraved. It consists of the following parts:

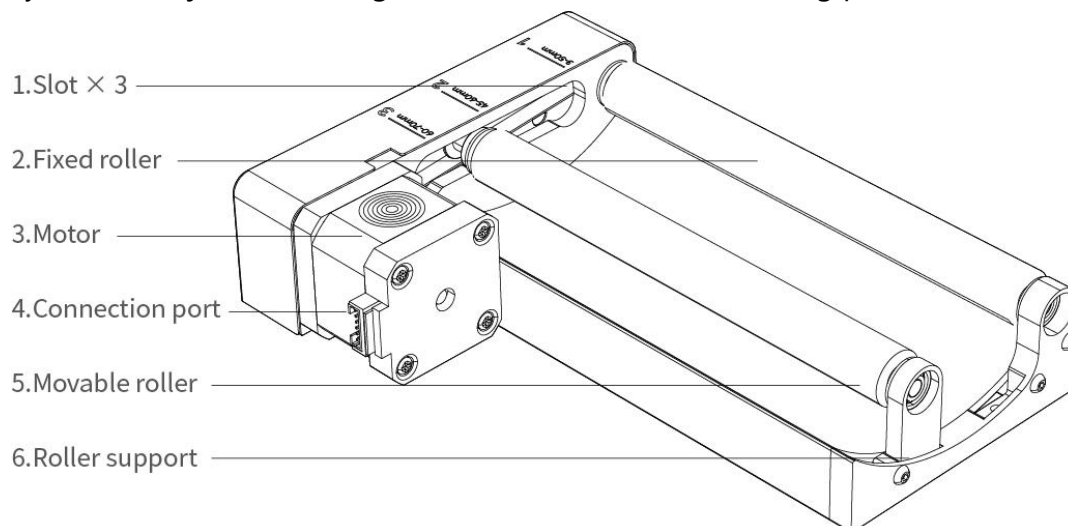

### Part 3: Installing the Engraving Module in the Laserbox Rotary

1. Before you begin, make sure the device is turned off. Open the lid of the device, remove the two screws in front of the honeycomb plate and remove the tray.



2. Remove the screws on both sides of the honeycomb plate and take out the honeycomb plate.





3. Remove the six screws on the back of the tray and remove the plate.

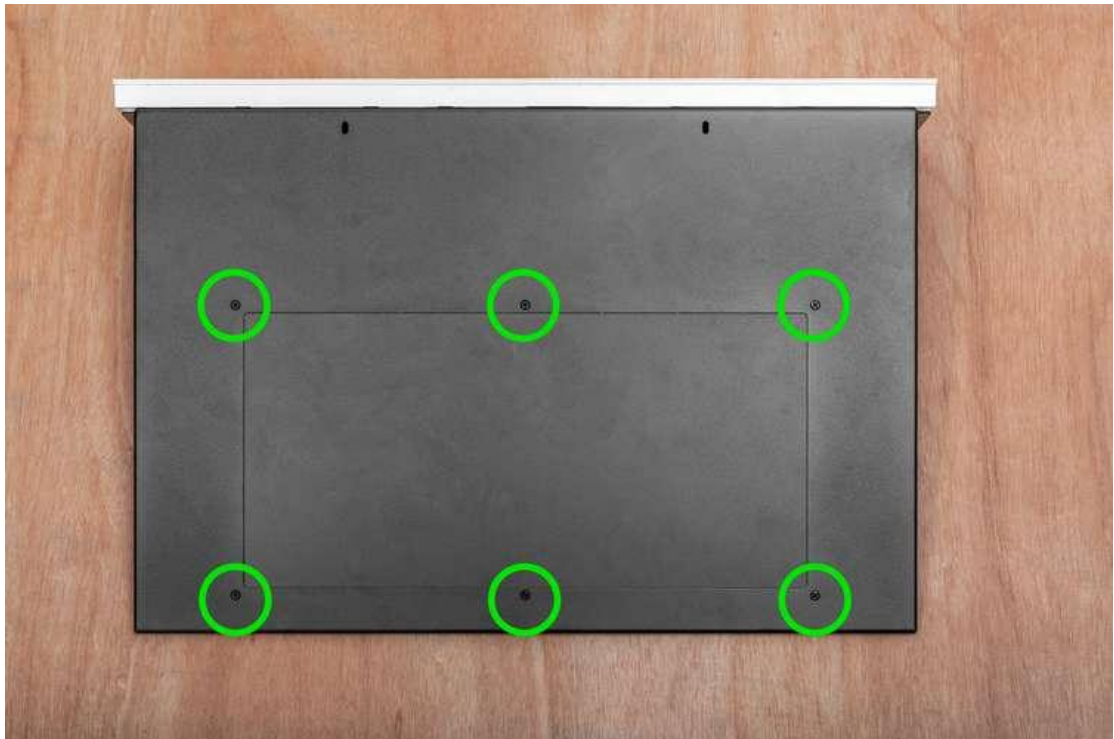

4. Put the tray back into the Laserbox Rotary.



5. Put the Rotary Roller Engraving Module on the position as shown in the image below, close to the green line (the green line is only for reference; it is not marked on the Laserbox Rotary).

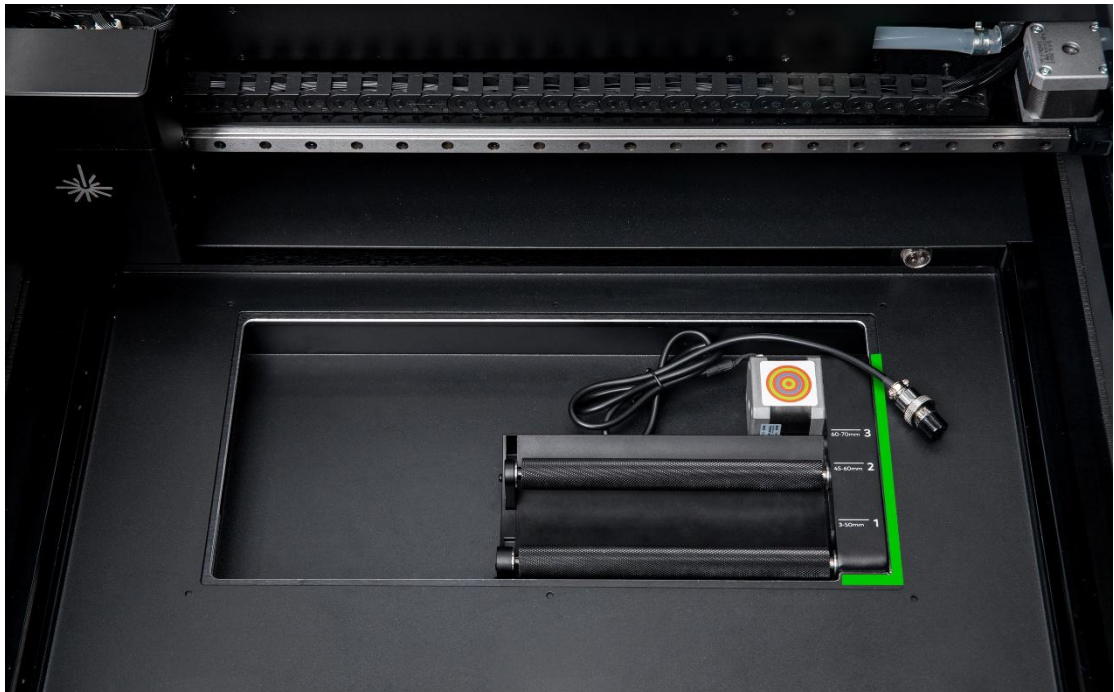

**Attention:**

Aligning the engraving module in the right position guarantees that the vertical axis of the cylinder is parallel to the vertical axis of the engraving operation.

6. Plug the cable of the Engraving Module into the aviation connector of the Laserbox Rotary and tighten the nut. Keep the connection cable as close to the bottom as possible to prevent laser damage to the cable.



**Attention:**

The pack contains 2 connection cables. For the Laserbox Rotary, please use the connection cable shown in the figure below. The remaining cable serves to connect the Engraving Module to a different device.



7. Turn on the Laserbox Rotary, open the Laserbox software and connect the device.

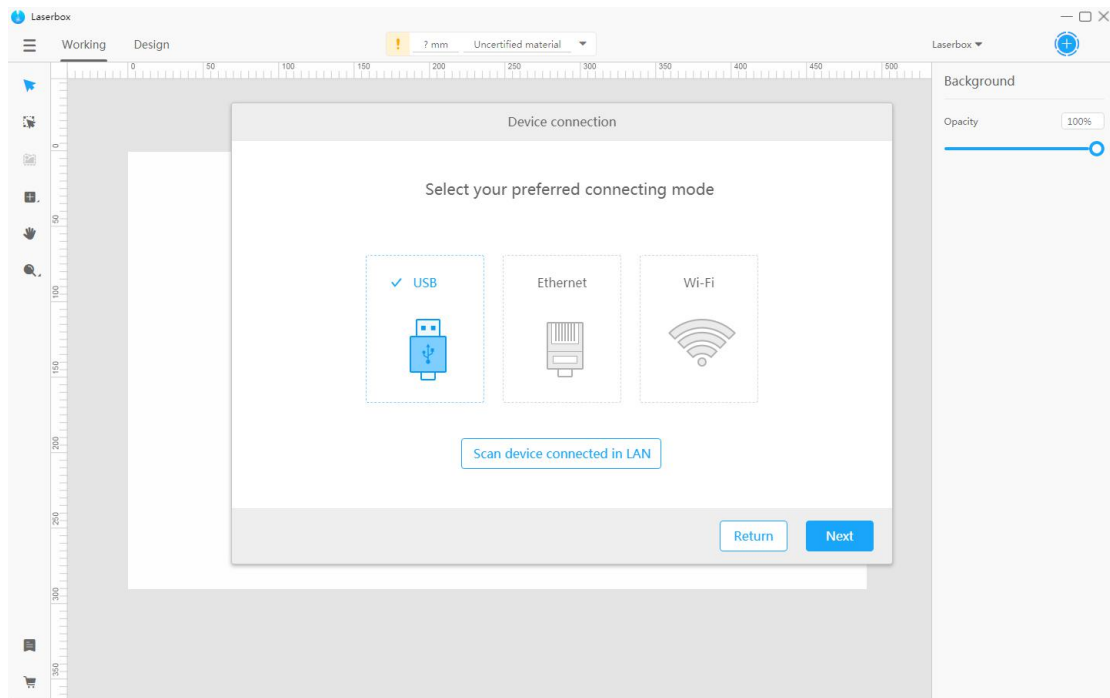

8. The software detects the Rotary Roller Engraving Module and automatically enters into cylinder engraving mode.

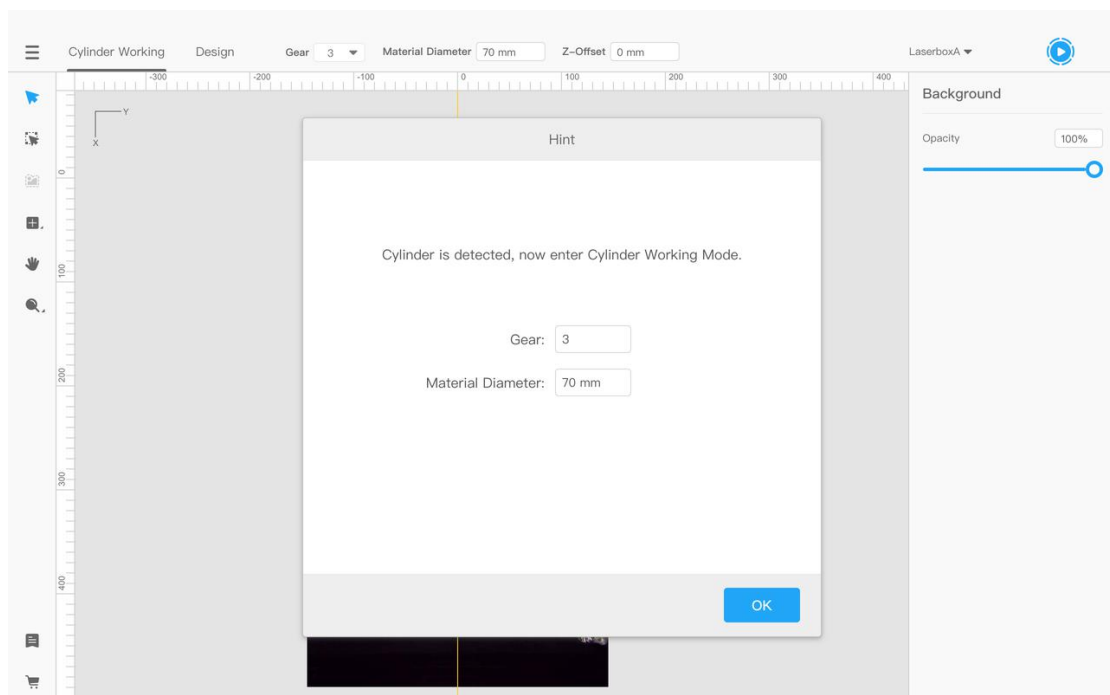

9. Measure the diameter of the cylinder to be engraved and change the movable roller to the corresponding position. For instructions on how to change the position of the movable roller, please read "**Part 4: Adjusting the position of the movable roller of the Engraving Module**" of this user guide.

**Attention:**

Laserbox Rotary can only engrave cylinders with a diameter between 3 to 70 millimeters.

10. When the object's diameter is less than 30mm, The Rotary Roller Engraving Module needs to be raised to reach the focus range of the laser. For example, if the diameter of the cylinder is 17mm, a flat object with a thickness of at least 13mm needs to be placed below the Rotary Roller Engraving Module.

Padding minimum thickness =  $30 - 17\text{mm} = 13\text{mm}$



If an object with a thickness of exactly 13mm cannot be found, an object with a thickness greater than 13mm can be used as the padding object. For instance, if the thickness of the object is 16mm, then 16mm will be filled in the z-axis offset on the Laserbox software.

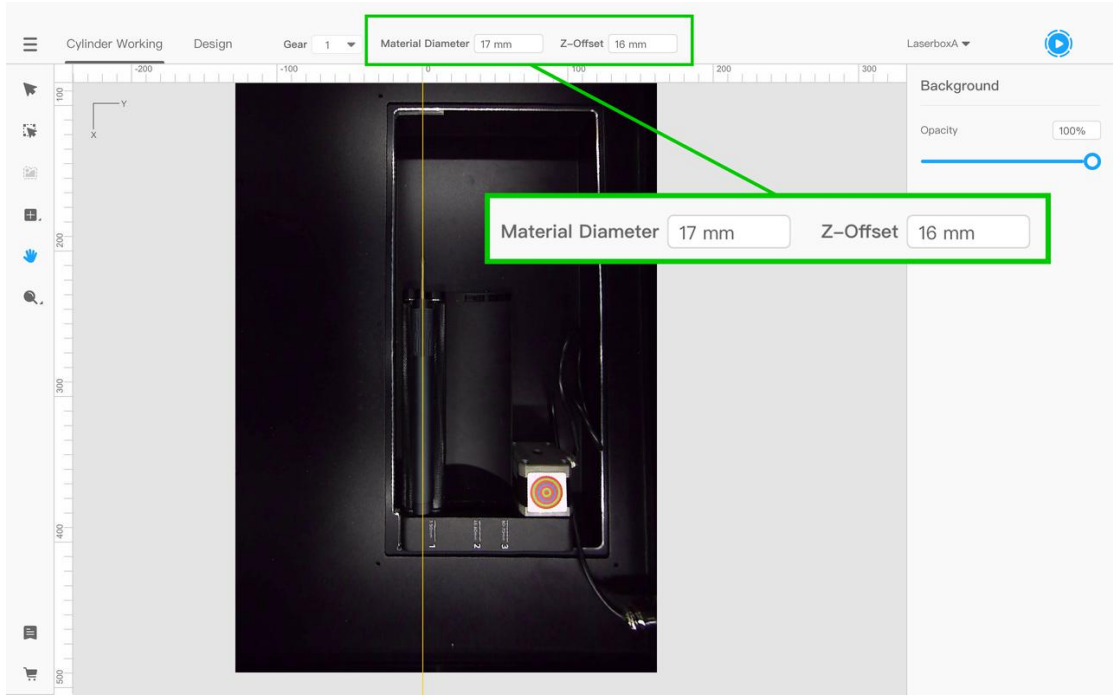



**Attention:**

If the surface of the engraved cylinder is very smooth, such as glass, you can put a strip of masking tape (easy-to-tear, grainy stickers) around the top and bottom of the cylinder to prevent it from slipping and misaligning while rotating.





11. After entering the engraving mode, the software will automatically show a yellow line at the axis position of the cylinder, which indicates the starting position where the engraving operation will begin. If the position of the yellow line is not on the axis of the object to be engraved, drag the yellow line to the axis of the object.

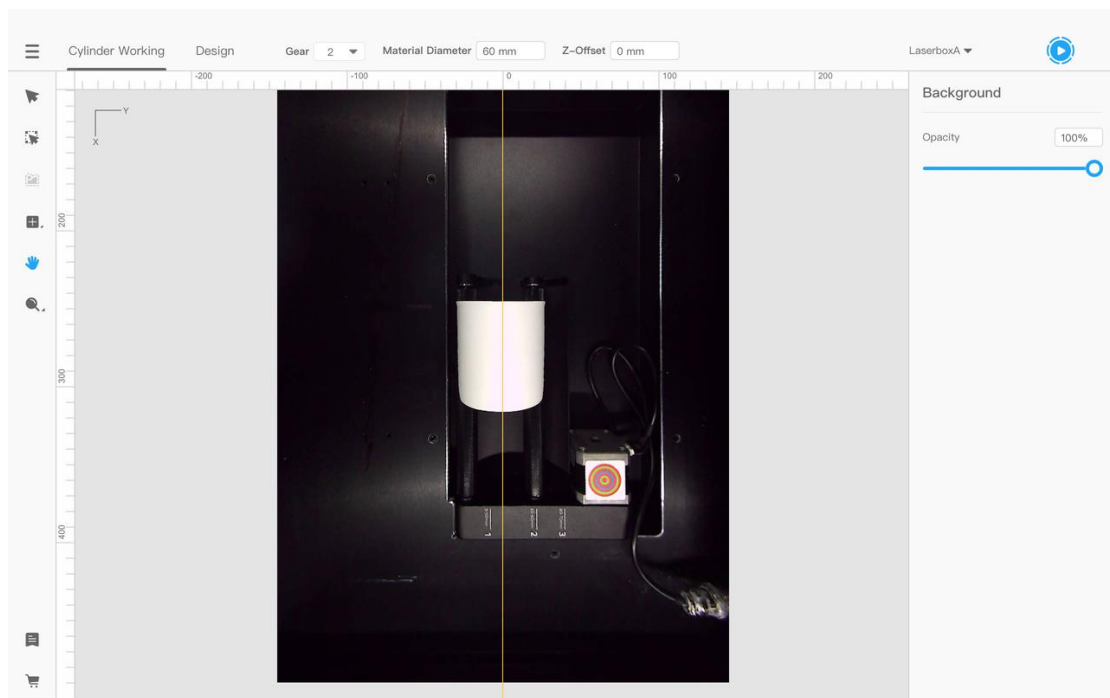

12. Import the design that you want to engrave.

13. Adjust the size of the design, as well as the engraving power and speed. For recommendations on power and speed settings for different materials, please read **“Part 6: Suggestions on power and speed parameters for certain materials”** of this user guide.

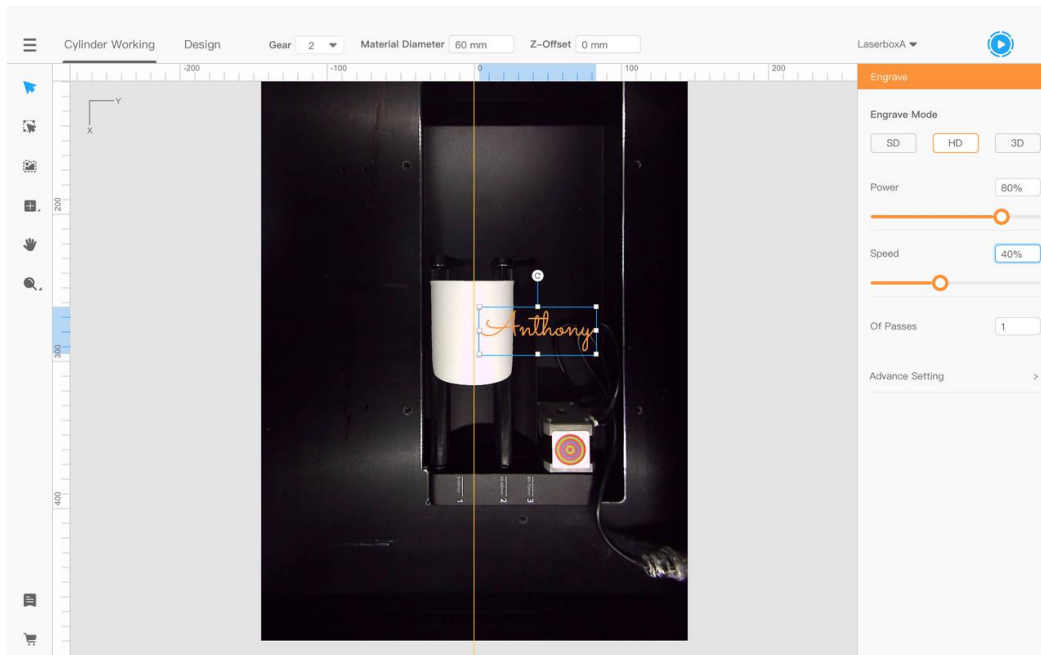

14. Drag and drop the design you want to engrave onto the desired location.

15. Click on the Send button.

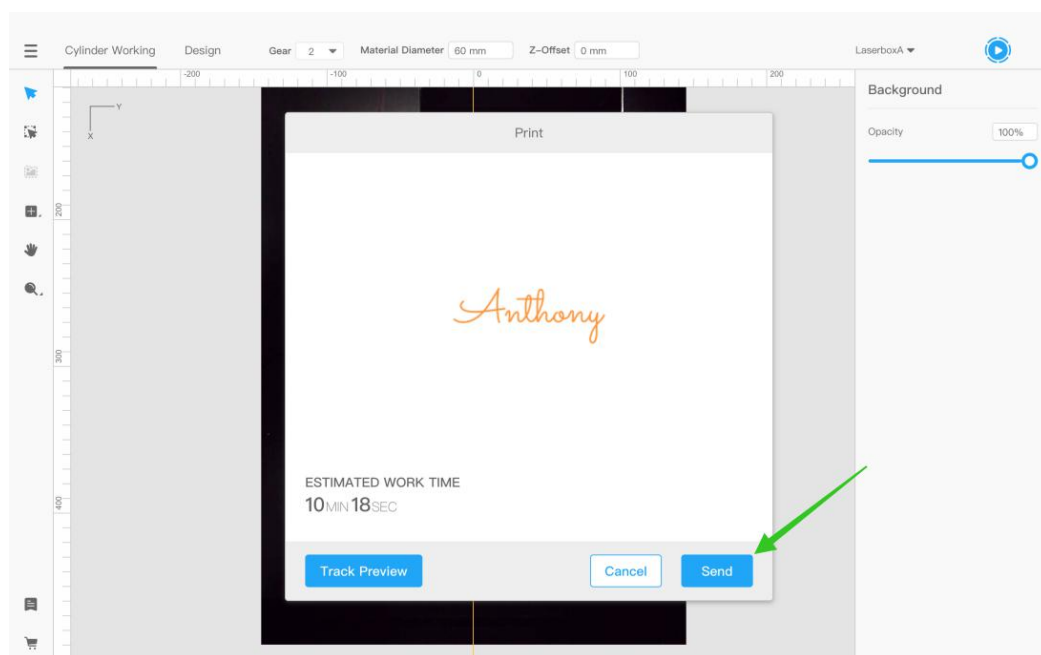

16. Press the start button on the Laserbox.

17. Once the engraving operation is finalized, open the lid and take out the object.



#### **Part 4: Adjusting the position of the movable roller of the Engraving Module**

1) Measure the diameter of the cylindrical item to be engraved, and determine the position according to the following table:

Position	Diameter (units: mms)
1	3-50
2	45-60
3	60-70

2) Set the engraving position. For example, you can take the following steps to change the engraving position from 2 to 1:

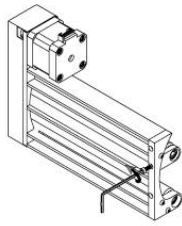

(1) Remove the screw of the movable roller.

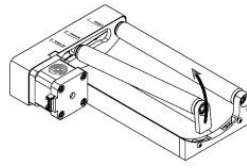

(2) Pull up the support of the movable roller.

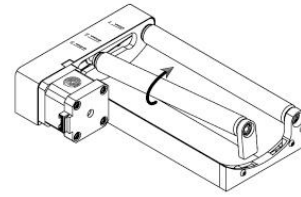

(3) Rotate the movable roller to the target position.

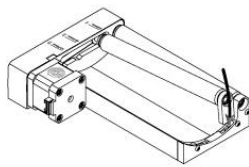

(4) Put the support of the movable roller into the corresponding slot and press it into place.

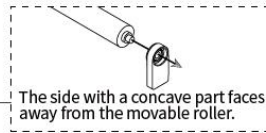

The side with a concave part faces away from the movable roller.



(5) Tighten the removed screw to the new position.

**Attention:**

Make sure that the circular label is not blocked or damaged. Otherwise, Laserbox Rotary may fail to identify the rotary engraving module.

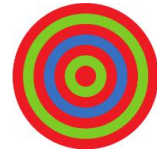

**Part 5: Switching from the cylindrical to the 2D work mode**

If you need to return to the 2D laser cutting / engraving mode, follow the next steps:

1. Turn off the Laserbox Rotary
2. Open the lid and unplug the cable from the Laserbox end of the Rotary Roller Engraving Module cable
3. Take out the Rotary Roller Engraving Module
4. Put back the honeycomb board and drawer and close the lid
5. Open the device and reconnect the software

**Attention:**

1. This process may result in Laserbox Rotary errors if the machine is not shut down as indicated in step 1
2. Try not to unplug the connection cable at the end of the Rotary Roller Engraving Module; this may lead to poor contact or even damage
3. If the interface has not returned to the 2D laser cutting / engraving mode, press Ctrl+shift+k on the keyboard at the same time, then it can automatically switch to 2D laser cutting / engraving mode

## Part 6: Suggestions on power and speed parameters for certain materials

Material engraving parameters table		
Material name	Power (%)	Speed (%)
Glass	100	20
Acrylic	50	80
Wood	50	80
Ceramic	100	20
Can	100	30
Stone	50	20

**Attention:**  
For reference only, specific materials may vary, users need to make adjustments according to the actual situation