



User manual

Lefant M213 Series Robot Vacuum Cleaner

Congratulations on the purchase of your Lefant ROBOTS!

We hope it brings you satisfaction. We trust your purchase will keep your home clean and provide you a high-quality life.

Should you encounter situations that have not been properly addressed in this User Manual, please contact our Customer Service Center, we will solve your specific problem. For more information, please visit the Lefant ROBOTICS official website: **www.lefant.com** or send email to **support@lefant.com**. The Company reserves the right to make technological and/or design changes to this product for continuous improvement.

IMPORTANT SAFETY INSTRUCTIONS

WARNING: Read all safety warnings and instructions. Failure to follow the warnings and instructions may result in electric shock, fire or serious injury. READ ALL INSTRUCTIONS BEFORE USING THIS APPLIANCE.

For Household use only

When using an electrical appliance, basic precautions should always be followed, including the following:

1. The robot must be used in accordance with the directions in this User Manual. Our company cannot be held liable or responsible for any damages or injuries caused by improper use.
2. Do not allow to be used as a toy. Close attention is necessary when used by or near children.x
Do not allow children to sit on the vacuum.
3. Clear the area to be cleaned. Remove power cords and small objects from the floor that could entangle the Robot. Tuck rug fringe under the rug base, and lift items such as curtains and table cloths off the floor.
4. If there is a drop off in the cleaning area due to a step or stairs, you should operate the Robot to ensure that it can detect the step necessary to place a physical barrier at the edge to keep the unit from falling. Make sure the physical barrier is not a trip hazard.
5. Only use as described in this manual. Only use attachments recommended or sold by the manufacturer.
6. Please make sure your power supply voltage matches the power voltage marked on the Docking Station.
7. Do not handle or plug appliance with wet hands.
8. Non-rechargeable batteries are prohibited.
9. Do not use without dust bin and/or filters in place.
10. Do not operate the robot in an area where there are lit candles or fragile objects on the floor to be cleaned.
11. Do not use and store in extremely hot or cold environments (below -5°C /23°F or above 40°C/104°F). Please charge the robot in temperature above 0°C/32°F and below 40°C/104°F. Follow all charging instructions and do not charge the battery pack or appliance outside

- of the temperature range specified in the instructions. Charging improperly or at temperatures outside of the specified range may damage the battery and increase the risk of fire.
12. Keep hair, loose clothing, fingers, and all parts of body away from any openings and moving parts.
13. Do not operate the robot in a room where an infant or child is sleeping.
14. For INDOOR use ONLY. Do not use the robot in outdoor, commercial or industrial environments. Do not use Appliance on wet surfaces or surfaces with standing water.
15. Do not allow the robot to pick up large objects like stones, large pieces of paper or any item that may clog the robot.
16. Do not use the robot to pick up flammable or combustible materials such as gasoline, printer or copier toner, or use in areas where they may be present.
17. Do not use the robot to pick up anything that is burning or smoking, such as cigarettes, matches, hot ashes, or anything that could cause a fire.
18. Do not put any object into openings. Do not use with any opening blocked; keep free of dust, lint, hair, and anything that may reduce air flow.
19. Take care not to damage the power cord. Do not pull on or carry the robot or the Docking Station by the power cord, use the power cord as a handle, close a door on the power cord, or pull power cord around sharp edges or corners. Do not run the robot over the power cord.Keep power cord away from hot surfaces. Do not unplug by pulling on cord, To unplug, grasp the plug, not the cord.
20. If the power cord is damaged, it must be replaced by the manufacturer or its service agent in order to avoid a hazard.







21. Do not use the Docking Station if it is damaged.
22. Do not use the robot or the Docking Station if it is not working properly, has been dropped, damaged, left outdoors, or come in contact with water. It must be repaired by the manufacturer or its service agent in order to avoid a hazard.
23. Turn OFF the power switch before cleaning or maintaining the robot. Turn off all controls
24. The plug must be removed from the receptacle before cleaning or maintaining the Docking Station.
25. Remove the robot from the Docking Station, and turn OFF the power switch to the Appliance before removing the battery for disposal of the robot.
26. The battery must be removed and discarded according to local laws and regulations before disposal of the robot.
27. Please dispose of used batteries according to local laws and regulations.
28. Do not incinerate the robot even if it is severely damaged. The batteries can explode in a fire.
29. When not using the Docking Station for a long period of time, please unplug it.
30. Prevent unintentional starting. Ensure the switch is in the off position before connecting to battery pack, picking up or carrying the appliance. Carrying the robot with your finger on the switch or energizing the robot that have the switch on invites accidents.
31. When battery pack is not in use, keep it away from other metal objects, like paper clips, coins, keys, nails, screws, ect, that can make a connection from one terminal to another. Shorting the battery terminals together may cause burns or a fire.
32. Under abusive conditions, liquid may be ejected from the battery; avoid contact. If contact accidentally occurs, flush with water. If liquid contacts eyes, additionally seek medical help. Liquid ejected from the battery may cause irritation or burns.
33. Do not use a battery pack that is damaged or modified. Damaged or

modified batteries may exhibit unpredictable behavior resulting in fire, explosion or risk of injury.

34. Do not expose a battery pack or appliance to fire or excessive temperature. Exposure to fire or temperature above 130°C/265°F may cause explosion.
35. Have servicing performed by a qualified repair person using only identical replacement parts.
36. Do not modify or attempt to repair the robot or the battery pack (as applicable) except as indicated in the instructions.
37. Do not operate the robot in a room that has lit candles on furniture that the vacuum may accidentally hit or bump into.
38. Recharge only with the charger specified by the manufacturer. A charger that is suitable for one type of battery pack may create a risk of fire when used with another battery pack.
39. Use the robot only with specifically designated battery packs. Use of any other battery packs may create a risk of injury and fire.
40. The robot contains batteries that are only replaceable by skilled persons. To replace the robot's battery, please contact Customer Service.
41. If the robot is not going to be used for a long time, fully charge the robot, power it OFF, and unplug the Docking Station.

SAVE THESE INSTRUCTIONS

To satisfy RF exposure requirements, a separation distance of 20 cm or more should be maintained between this device and persons during device operation. To ensure compliance, operations at closer than this distance is not recommended. The antenna used for this transmitter must not be co-located in conjunction with any other antenna or transmitter.

| | |
|---|--|
|  | Short-circuit-proof safety isolating transformer |
|  | Switch mode power supply |
|  | For indoor use only |
|  | Direct current |
|  | Alternating current |
|  | detachable supply unit |

Correct Disposal of this Product

This marking indicates that this product should not be disposed of with other household waste throughout the EU. To prevent possible harm to the environment or human health from uncontrolled waste disposal, recycle it responsibly to promote the sustainable reuse of material resources. To recycle your used device, please use the return and collection systems or contact the retailer where the product was purchased. They can safely recycle this product.



Federal Communications Commission (FCC) Interference Statement

This equipment has been tested and found to comply with the limits for a Class B digital device, pursuant to Part 15 of the FCC Rules.

These limits are designed to provide reasonable protection against harmful interference in a residential installation. This equipment generate, uses and can radiate radio frequency energy and, if not installed and used in accordance with the instructions, may cause harmful interference to radio communications.

However, there is no guarantee that interference will not occur in a particular installation. If this equipment does cause harmful interference to radio or television reception, which can be determined by turning the equipment off and on, the user is encouraged to try to correct the interference by one of the following measures:

- Reorient or relocate the receiving antenna.
- Increase the separation between the equipment and receiver.
- Connect the equipment into an outlet on a circuit different from that to which the receiver is connected.
- Consult the dealer or an experienced radio/TV technician for help.

This device complies with Part 15 of the FCC Rules.

Operation is subject to the following two conditions:

(1) This device may not cause harmful interference, and (2) this device must accept any interference received, including interference that may cause undesired operation.

FCC Caution:

Any changes or modifications not expressly approved by the party responsible for compliance could void the user's authority to operate this equipment.

RF exposure warning

This equipment complies with FCC radiation exposure limits set forth for an uncontrolled environment. This equipment must be installed and operated in accordance with provided instructions and the antenna(s) used for this transmitter must be installed antenna(s) used for this transmitter must be installed to provide a separation distance of at least 20 cm from all persons and must not be collocated or operating in conjunction with any other antenna or transmitter.

Contents

| | |
|------------------------------------|-----------|
| 1. Product introduction | 7 |
| 1.1 Packing list | |
| 1.2 Part name | |
| 2. Preparation | 10 |
| 2.1 Assemble and charge | |
| 2.2 Using environment preparation | |
| 3. Using the product | 12 |
| 3.1 How to use buttons | |
| 3.2 App download and configuration | |
| 3.3 Maintenance | |
| 4. Abnormal symptoms | 16 |
| 4.1 Symptom prompts | |
| 4.2 Troubleshooting | |
| 5. Technical parameters | 18 |

1. Product introduction / 1.1 Packing list

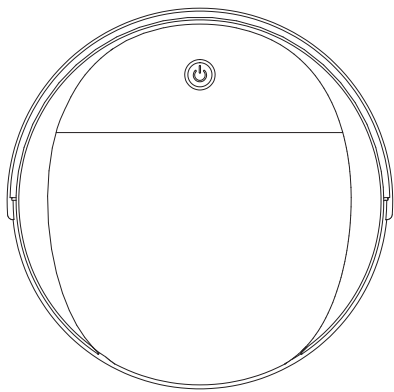

Robot vacuum cleaner

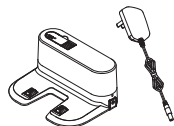

Docking Station & AC Adapter

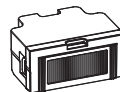

Dust bin

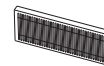

High Efficient Particulate Air (HEPA) Filter



Side brush



Cleaning tool



User manual

Note: Figures and illustrations are for reference only and may differ from actual product appearance. Product design and specifications are subject to changes without notice.

1. Product introduction / 1.2 Part Name

Front view

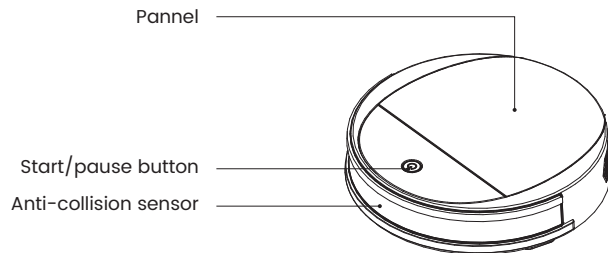

Internal view

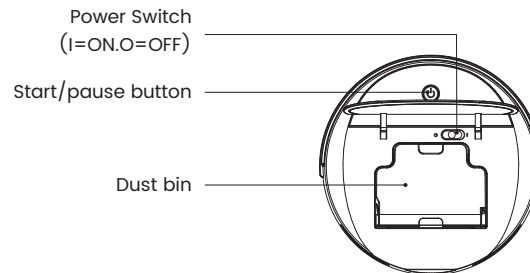

Bottom view

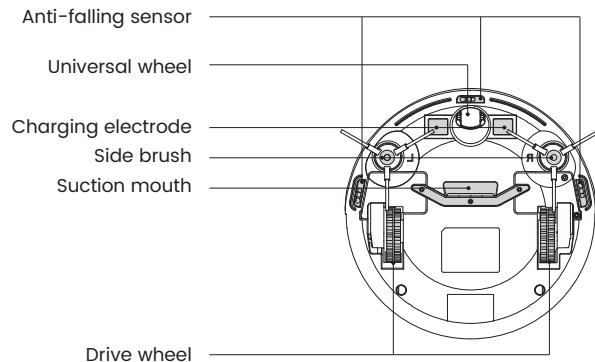

Docking Station

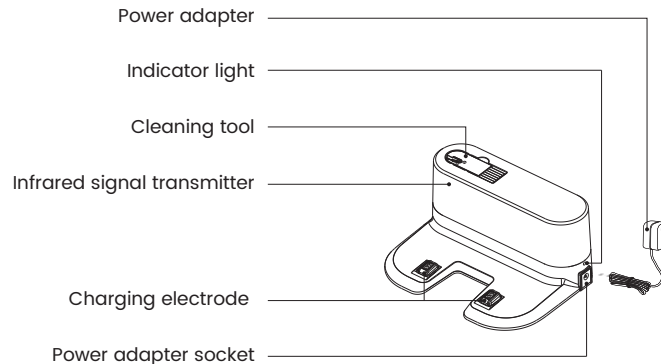

1. Product introduction / 1.2 Part Name

Dust bin

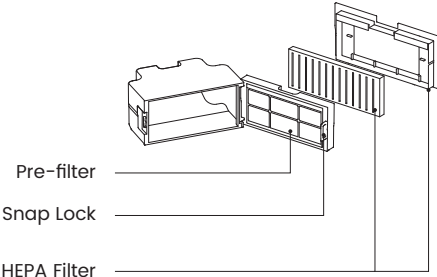

2. Preparation / 2.1 Assemble and charge

- 1** Remove the protective film on the robot and docking station

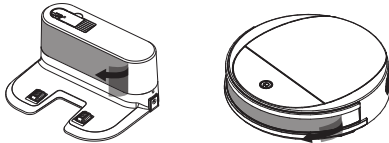

- 2** Install the side brushes

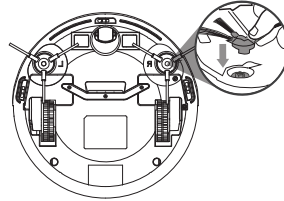

- 3** Placement of the charging base / connection of power supply

- * Place the docking station on an open place.
- * Connect the power supply and tidy up the power cord to avoid tripping.

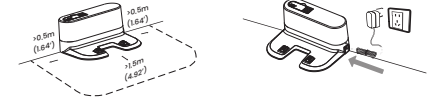

- 4** Turn on the robot

" I " means ON , " O " means OFF

- ⚠ Reminder: Cannot charge when product is turned off.

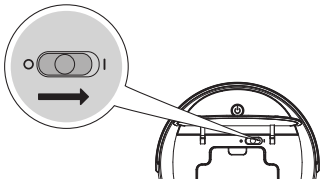

- 5** Charging

Place the robot at Docking Station and make sure to align the charging electrodes

- 🔆 twinkling means charging.
- 🔆 turn off means fully charged.

A full charge takes 3.5 hours.

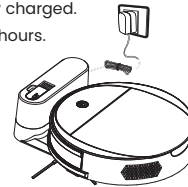

2. Preparation / 2.2 Using environment preparation

Tidy up the room

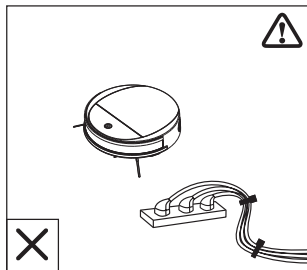

Organize the items on the floor, such as wires, slippers and other sundries to avoid affecting the operation of the robot

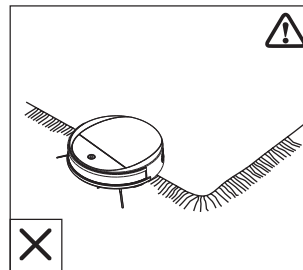

If the rug at home has fringed edges, please put the edges under the rug in advance.

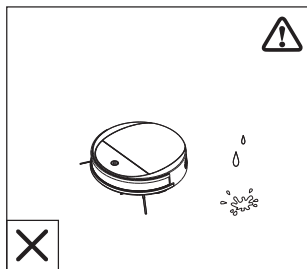

Do not let the robot operate on wet floors.

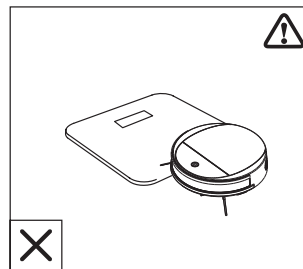

The robot can climb to the top of objects with a height of less than 12mm. If you don't want the robot to climb on them, please take them away.

3. Using the product / 3.1 How to use buttons

Single press: **Start/pause**

Double press: **Automatic return and charge**

Keep pressing for 3 seconds: **Entering Wi-Fi pairing mode**

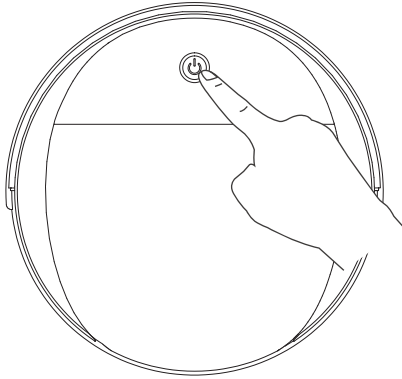

Indicator Meaning

| Robot status | Indicator status |
|---|-------------------------|
| Cleaning | Blue light on |
| Pause/standby | Blue light on |
| Charging | Purple/blue light flash |
| Low battery-automatic return and charge | Red light on |
| Cleaning complete-automatic return and charge | Purple light is on |
| Entering Wi-Fi pairing mode | Blue light flash |
| Error | Red light on/flash |

3. Using the product / 3.2 App download and configuration

Downloading and installation of the “Lefant” app

Method I : Scan the following QR code, and then download and install App as prompted.



Method II : Search “Lefant” in the App store, download and install the Lefant app.

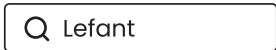

Note: The robot works with 2.4GHz Wi-Fi networks only.

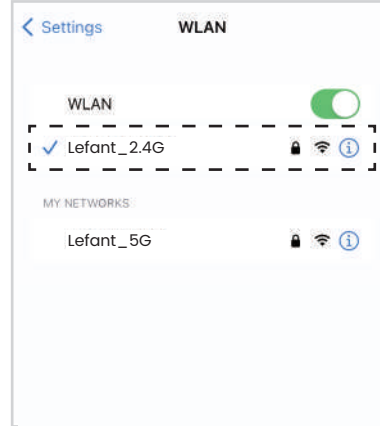

Tips:

- * Follow the guidance in the Lefant app to register, login, and pair the robot.
- * Please make sure that the mobile phone is connected to your Wi-Fi network before pairing the robot vacuum cleaner.

3. Using the product / 3.3 Maintenance

* When cleaning and maintaining the robot and its accessories, please unplug the charging stand.

Warning

The HEPA Filter should not touch the water.



- 1** Open the faceplate and take out the dust bin

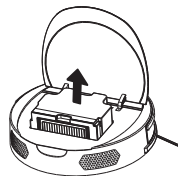

- 2** Open the dust bin latch and dump the garbage

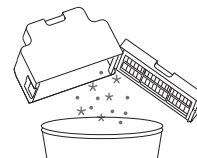

- 3** Remove the filter assembly

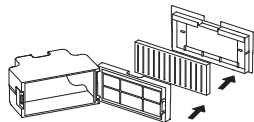

- 4** Clean the Pre-filter

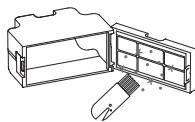

- 5** Clean the HEPA-filter



3. Using the product / 3.3 Maintenance

* When cleaning and maintaining the robot and its accessories, please unplug the charging stand.

1. Clean the anti-drop sensor to ensure the sensitivity of the sensor

2. Clean the universal wheel to prevent hair from tangling

3. Clean the charging electrode to ensure successful charging

4. Clean the suction mouth to avoid dust clogging

5. Clean the driving wheel to ensure clean smoothly

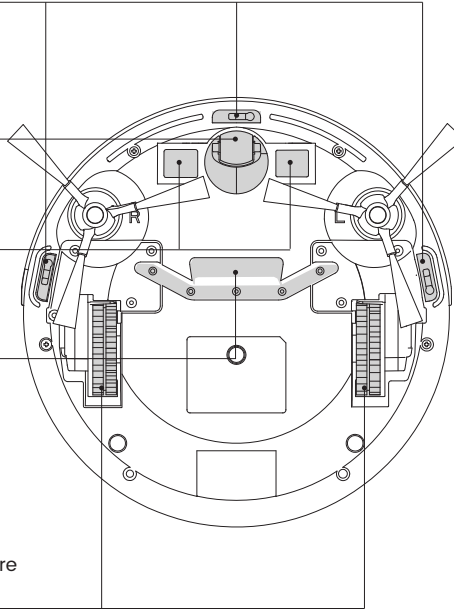

6. Clean the Anti-collision sensors to ensure sensitive obstacle avoidance

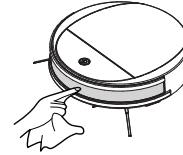

7. Clean the side brush to prevent hair from tangling

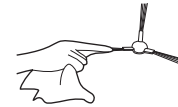

8. Clean the charging electrode of the docking station to ensure successful charging



4. Abnormal symptoms / 4.1 Symptoms prompts

When the robot runs into trouble, its red indicator light will be on or flash and beep with different durations and separations. The following table summarizes the corresponding causes:

| No. | Fault cause | Prompt sound | Solutions |
|----------------------------|------------------------|-------------------------|---|
| The red light is on | | | |
| 1 | Abnormal driving wheel | 1 beep for three times | Please check whether the driving wheel is tangled , and clean up it. |
| 2 | Abnormal side brush | 2 beeps for three times | Please check whether the side brush is tangled , and clean up the side brush. |
| 3 | Abnormal fan | 3 beeps for three times | Please check the waste in the dust bin and the air duct. |
| 4 | Undetected dust bin | 5 beeps for three times | Please install the dust bin in the robot. |

| | | | |
|--------------------------|---------------------------|-------------------------|---|
| Red light flashes | | | |
| 1 | Ground-detection alarm | 2 beeps for three times | The robot hangs in the air. Please move it to the ground. |
| 2 | Dilemma elimination alarm | 3 beeps for three times | Fail to get rid of a dilemma; please move to an open place. |
| 3 | Low Battery | 4 beeps for three times | Please move the robot to the docking station for charging. |
| 4 | Abnormal adapter | 5 beeps for three times | Clean the electrode and ensure the original adapter. |
| 5 | Abnormal charging | 6 beeps for three times | Check if the robot is turned on. |

* If the above method cannot resolve the problem, please try the following operations: turn on the ON/OFF button under the faceplate to restart the robot.



4. Abnormal symptoms / 4.2 Troubleshooting

If the following problems occur in the application process of the product, users can resolve them independently by comparison and inquiry.

| S/N | Fault | Possible causes | Solutions |
|-----|--------------------------------|--|---|
| 1 | Abnormal cleaning | Cleaning components blockage | It is recommended to replace consumables regularly, such as high-efficiency filters (HEPA), pre-filter, side brushes, etc. |
| | | Dust on sensors and other components | Please refer to the chapter [Maintenance] of the manual to clean the robot. |
| 2 | Unable to connect to App | Not entered Wi-Fi pairing mode | Keep pressing the Start/pause button for 3 seconds: Entering Wi-Fi pairing mode. Please refer to the manual's chapter [App download and configuration]. |
| | | 2.4G Hz network isn't used. | Please refer to the manual's chapter [App download and configuration]. |
| 3 | Difficult to return and charge | Incorrect placement of charging base | Please place the charging stand in an open and flat area. |
| | | The charging stand is powered off or moved manually | Please check whether the charging base is connected to the power supply. Do not move the position of the charging base when the robot is working. |
| | | The home is too large, and the environment is complex | Please refer to the chapter [Using environment preparation] of the manual. If the home environment is too complex, it is recommended to use multiple charging stands. |
| | | The robot didn't clean from the docking station | Let the robot clean from the docking station. |
| 4 | Unable to charge | The power supply is not connected, or the plug is loose | Check whether both ends of the power adapter are connected and powered on normally. |
| | | Poor contact between the robot and the charging electrode of the docking station | Ensure that the charging electrode of the robot and the charging base are fully connected, and clean the charging electrode of the robot and the docking station regularly. |
| | | Battery deterioration caused by non-long-term use | It is recommended to use this product frequently. If the battery cannot be charged due to not using it for a long time, please contact a customer service representative. |

* If the fault cannot be eliminated according to the operation in the table, contact our customer service representative.

5. Technical parameters

| | | | |
|-------------------------|---|----------------------|------|
| Product model | M213 Series | | |
| Rated input of machine | 19V  0.6A, 11.4W | | |
| Docking Station Model | LI | | |
| Rated Output Voltage | 19V  | Rated Output Current | 0.6A |
| Power Adapter Model | AD-0121900060US/UK | | |
| Power Adapter Input | 100-240V~ 50-60Hz 0.5A | | |
| Power Adapter Output | DC 19V, 0.6A, CLASS II | | |
| Off/Standby Mode Power | Less than 0.5W | | |
| Networked Standby Power | Less than 2.00W | | |

Note: Since the product needs continuous improvement, the actual product shall prevail.
Our company reserves the right to update the product.

Warranty

This warranty covers the repair or replacement of the malfunction device at our company's discretion for a period of 1-year. In addition this certificate is void if altered. The serial number must be provided as well as all accessories to be eligible for warranty coverage. Please kindly fill in below form accurately and completely.

Order Number: _____

Serial Number: _____

Date of Purchase: _____

Important:

When returning this device, carefully pack the product to avoid damage in shipping. Damage in shipping is not covered by the Warranty and shall be the sole responsibility of Buyer. Damage or loss not covered by this Warranty or occurring outside the Warranty Period will require a fee to cover the cost of handling and shipping. All such fees and costs shall be the sole responsibility of Buyer.

Exclusion

Unless agreed in writing, the warranty will not apply if the defects relate to:

- Consumable parts such as filters, or brushes etc, that are subject to normal wear and tear, and require regular maintenance and/or replacement to ensure the proper functioning of your unit.
- Defects caused by rough or inappropriate handling or use or damage caused by accident, misuse, neglect, fire, water, lighting or other acts of nature, external sources such as weather, electrical outages or power surges.
- Improper operation or maintenance, use not in accordance with the product instructions or connection to improper voltage supply.
- Accident, abuse, misapplication, or any unauthorized repair, modification, or disassembly of the product.
- Any failure to adequately package the Product for transportation.
- Use of parts not in accordance with the product instructions.
- Use of parts and accessories other than those produced or recommended by our company.
- Use in a commercial environment as the Product is designed for residential use only.
- Consequential and incidental damages.
- Any product(s) purchased from unauthorized dealers/resellers.
- Products used outside the country of purchase.
- Lost and/or stolen products.



Official website

🌐 Website: www.lefant.com

✉ Email: support@lefant.com

📘 Facebook: [@LEFANTOFFICIAL](https://www.facebook.com/LEFANTOFFICIAL)

🌐 Community: [facebook.com/groups/Lefantofficialcommunity](https://www.facebook.com/groups/Lefantofficialcommunity)

Shenzhen Iohas Technology Co., LTD.

Building 2, Fashion Brand Industrial Park, E'bu Town,
Shenzhen-Shanwei Special Cooperation Zone, Shenzhen, Guangdong, China.

M213-LH20220527-V01