

User Manual of Product 1:

iRobot Roomba 692 Robot Vacuum-Wi-Fi Connectivity,
Personalized Cleaning Recommendations, Works with Alexa,
Good for Pet Hair, Carpets, Hard Floors, Self-Charging,
Charcoal Grey

Robot[®]

Roomba[®]

Vacuuming Robot

**600 Series
Owner's Guide**

Important Safety Instructions

This owner's guide includes information for Roomba vacuum cleaner Model(s): 670-679 and 690-699.

SAVE THESE INSTRUCTIONS

 **WARNING:** When using an electrical appliance, basic precautions should always be followed, including the following:

READ ALL INSTRUCTIONS BEFORE USE

 **WARNING:** To reduce the risk of injury or damage, read and follow the safety precautions when setting up, using and maintaining your robot.

This appliance can be used by children aged from 8 years and above and persons with reduced physical, sensory or mental capabilities or lack of experience and knowledge if they have been given supervision or instruction concerning use of the appliance in a safe way and understand the hazards involved. Children shall not play with the appliance. Cleaning and user maintenance shall not be made by children without supervision.

 This is the safety alert symbol. It is used to alert you to potential physical injury hazards. Obey all safety messages that follow this symbol to avoid possible injury or death.

 Risk of electric shock

 Class II equipment

 Rated power output, d.c.

 Read operator's manual

 General symbol for recycling

 Risk of fire

 For indoor use only

 Rated power input, d.c.

 Keep out of reach of children

BFP Backfeed Protection

 Rated power input, a.c.

WARNING: Indicates a hazardous situation that, if not avoided, could result in death or serious injury.

CAUTION: Indicates a hazardous situation that, if not avoided, could result in minor or moderate injury.

NOTICE: Indicates a hazardous situation that, if not avoided, could result in property damage.

GENERAL



- Your robot is not a toy. Small children and pets should be supervised when your robot is operating.
- Do not sit or stand on your robot or Home Base.
- Do not use unauthorized chargers. Use of an unauthorized charger could cause the battery to generate heat, smoke, catch fire, or explode.
- Your robot comes with a region approved power supply cord and is designed to be plugged into a standard household AC power outlet only. Do not use any other power supply cord. For replacement cords, please contact Customer Care to ensure proper selection of country specific power supply cord.
- Do not open your robot except as instructed to install or replace the battery or maintain the dust bin and filter(s). Do not open the integrated dock-charger, known as Home Base. There are no user serviceable parts inside. Refer servicing to qualified service personnel.
- Risk of electric shock, use indoors in dry location only.
- Do not handle your robot or Home Base with wet hands.
- Store and operate this product in room temperature environments only.
- If the room to be cleaned contains a balcony, a physical barrier should be used to prevent access to the balcony and ensure safe operation.

- Do not operate the robot in areas with exposed electrical outlets in the floor.

ROBOT



- If the robot passes over a power cord and drags it, there is a chance an object could be pulled off a table or shelf. Before using the robot, pick up objects like clothing, loose papers, pull cords for blinds or curtains, power cords, and any fragile objects.
- Be aware that the robot moves on its own. Take care when walking in the area that the robot is operating in to avoid stepping on it.
- Do not use the robot to pick up sharp objects, glass, or anything that is burning or smoking.

NOTICE

- This robot is intended for dry floor use only. Do not use the robot to pick up spills. Do not allow your robot or dirt disposal to become wet.
- Do not place anything on top of your robot.
- The failure to maintain cleanliness of charger contacts could result in loss of ability for the robot to charge the battery.

HOME BASE



- If appliance is not working as it should, has been dropped, damaged, left outdoors, or dropped into water, return it to a service center
- Always disconnect your robot from the Home Base before

cleaning or maintaining it. Use only as described in this manual.

- Only use the battery charger model 17070 to charge the iRobot model 1800Li battery, Battery Charger model 17070: Input AC 100-240 VAC, 50-60Hz, Output 20.5 VDC, 1.25A.
- Only charge one of the following iRobot batteries: maximum 14.4V, max 2000mAh Ni-MH or maximum 14.4-14.8V, max 3300mAh Li-ion battery. Other type of batteries may burst causing injury. Always contact Customer Care for the correct replacement of your battery.

NOTICE

- Product may not be used with any type of power converter. Use of power converters will immediately void the warranty.
- If you live in an area prone to electrical storms, it is recommended that you use additional surge protection. Your robot's Home Base may be protected with a surge protector in the event of severe electrical storms.

BATTERY



WARNING



- Do not open, crush, heat above 176°F: 80°C, or incinerate. Follow manufacturer's instructions.
- Do not short-circuit the battery by allowing metal objects to contact battery terminals or immerse in liquid. Do not subject batteries to mechanical shock.
- Periodically inspect the battery pack for any sign of damage or leakage. Immediately stop using the battery if there are noticeable abnormalities, such as smell, heat, discoloration or deformity.
- Do not charge damaged or leaking battery packs, do not allow the liquid to come in contact with skin or eyes. If contact has been made, wash the affected area with copious amounts

of water and seek medical advice. Place the battery in a sealed plastic bag and recycle or dispose of safely according to local environmental regulations, or return it to your local authorized iRobot Service Center for disposal.



CAUTION



- Battery usage by children should be supervised. Seek medical advice immediately if a cell or a battery has been swallowed.

NOTICE

- The battery pack must be removed from the robot before recycling or disposal.
- For best results, use only the iRobot Lithium Ion Battery that comes with the robot.
- For replacement, purchase identical iRobot battery or contact iRobot Customer Care for alternative battery options.
- Do not use non-rechargeable batteries.
- Always charge and remove the battery from your robot and accessories before long-term storage.

17070:

NOMINAL ELECTRICAL CHARACTERISTICS	
Input voltage: 100-240 V	Input frequency: 50-60 Hz
Output voltage: 20.5 VDC	Current output: 1.25 A



This symbol on the battery indicates that the battery must not be disposed of with unsorted common municipal waste. As the end-user, it is your responsibility to dispose of the end-of-life battery in your appliance in an environmentally sensitive manner as follows:

- (1) returning it to the distributor/dealer from whom you purchased the product; or
- (2) depositing it at a designated collection point

The separate collection and recycling of end-of-life batteries at the time of disposal will help to conserve natural resources and to ensure that batteries are recycled in a manner that protects human health and the environment. For more information, please contact your local recycling office or the dealer from whom you originally purchased the product. Failure to properly dispose of end-of-life batteries may potentially result in negative effects on the environment and human health due to the substances in the batteries and accumulators.

Table of Contents

Important Safety Information	i
About Your Roomba®	2
Using Your Roomba®	3
Accessories.....	4
Regular Robot Care	5
Troubleshooting	8
iRobot Customer Care.....	9
Regulatory Information.....	10

About your Roomba

Top View



Buttons & Indicators

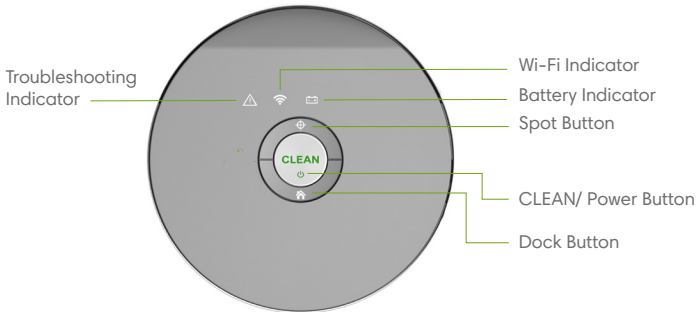

Home Base

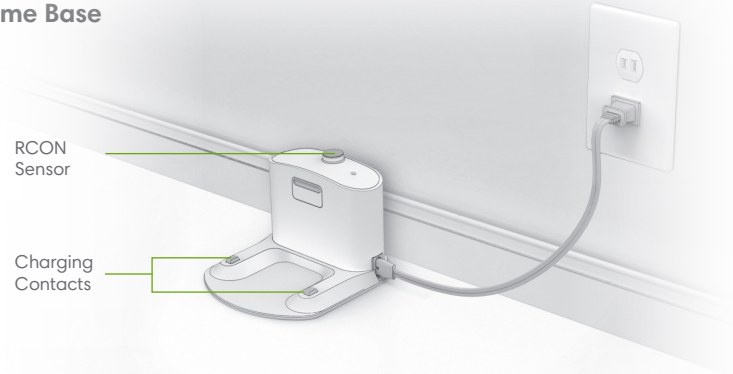

Bottom View

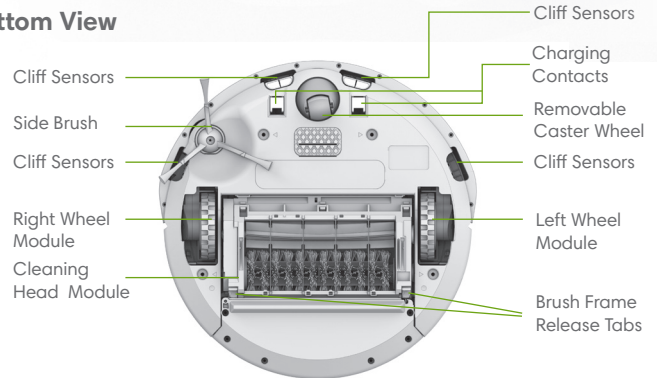

Using your Roomba

Positioning the Home Base®

Place the Home Base in an open, uncluttered area leaving the following distances around the Home Base:

- At least 1.5 feet (0.5 meters) on each side of the Home Base
- At least 4 feet (1 meter) in front of the Home Base, and at least 4 feet (1 meter) away from stairs
- At least 8 feet (2.5 meters) from Virtual Wall Barriers

Always keep the Home Base plugged in and make sure it is in an area with consistent Wi-Fi® coverage to allow Roomba to receive information via the iRobot HOME App.

Download the iRobot HOME App and connect to Wi-Fi®:

- Watch an overview video with instructions on how to set-up and use your Roomba
- Set an automatic cleaning schedule (up to 7 times per week)
- Enable automatic Software updates
- Access to tips, tricks, and answers to commonly asked questions





Use Instructions

- Turn your robot over and remove the bin insert and battery pull tabs. Then place Roomba on the Home Base to activate the battery.
- Roomba has a partial battery charge, so it's ready to start cleaning.

 **Note:** Roomba ships with a partial battery charge. If you start a cleaning cycle before charging the battery fully, Roomba may return to the Home Base to recharge sooner than it will during future cleaning cycles. To fully charge the battery before the first cleaning cycle, allow Roomba to charge on the Home Base for 3 hours.

 **Note:** Remove excess clutter from floors before cleaning (e.g. clothing, toys, etc.). Use Roomba frequently to maintain well-conditioned floors.

- To begin a cleaning cycle, press CLEAN on the robot or in the iRobot HOME App.
- Pre-set your robot to automatically vacuum up to seven times per week using the Scheduling feature in the iRobot HOME App.
- When Roomba returns to the Home Base after completing a cleaning cycle, it will play a series of tones to indicate successful completion of the cleaning cycle.
- To pause Roomba during a cleaning cycle, press CLEAN. To resume the cleaning cycle, press CLEAN again.
- To end the cleaning cycle and put Roomba in standby mode, press and hold CLEAN until Roomba's indicators turn off.
- To send Roomba back to its Home Base during a cleaning cycle, press CLEAN and then  (DOCK) on Roomba or press CLEAN on the iRobot HOME App main screen. This will end the cleaning cycle.
- If Roomba encounters an area of high debris concentration, it will move in a spiral motion to clean the area more thoroughly. When Roomba does this, the CLEAN button will blink.
- To use SPOT Cleaning, place Roomba on top of the localized debris and press  (SPOT) on the robot. Roomba will intensely clean the area by spiraling outward about 3 feet (1 meter) in diameter and then spiraling inward to where it started.

 **Note:** After each use, empty the bin and clean the filter.

- Always store Roomba on the Home Base so it's charged and ready to clean when you need it. If storing off of the Home Base, remove the battery first and then store Roomba and the battery in a cool, dry place.

Battery and Charging

Charge Roomba using the Home Base. Indicator lights will turn off after 60 seconds to conserve energy while Roomba is charging. Check status of the battery by pressing the CLEAN button to illuminate the Battery Indicator. Indicator will appear amber while the battery is charging and solid green when fully charged.

Accessories

The Dual Mode Virtual Wall Barrier

(optional accessory for all models)

The Dual Mode Virtual Wall barrier keeps Roomba in the places you want to be cleaned — and out of the ones you don't. In between cleaning cycles, you can leave the device operating in its position on the floor. You can set your device to one of two modes to fit your home's cleaning needs:

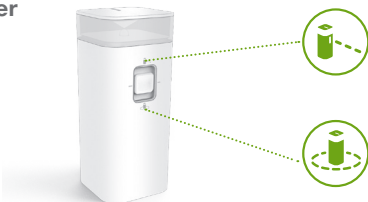

Note: Under normal use, batteries will last 8-10 months. If you are not planning on using your Virtual Wall device for an extended period of time and you would like to store it, be sure to switch it to the "Off" (middle) position.

Virtual Wall Mode: When the switch is in the "up" position (↑), the device functions as a Virtual Wall. This means that you can set it to block openings of up to 10 feet (3 meters). It creates an invisible, cone-shaped barrier that only Roomba can see.

Note: This barrier gets wider as it gets further from the device (refer to illustration).

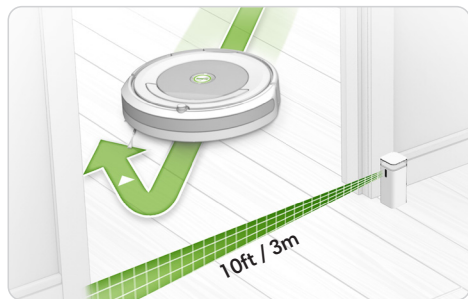

Halo Mode: When the switch is in the "down" position (↓), the device creates a protective zone that Roomba will not enter. This prevents Roomba from bumping into items you want to protect (e.g. a dog bowl or vase) or crossing into undesired areas (e.g. a corner or under a desk). The Halo is invisible and reaches approximately 12 inches (30 centimeters) from the center of the device.

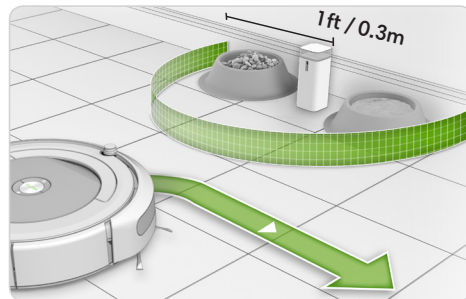

Regular Robot Care

Recommended Robot Care

To keep Roomba running at peak performance, perform the following care procedures. Instructional care videos can also be viewed in the iRobot HOME App. If you notice Roomba picking up less debris from your floor, then empty the bin, clean the filter and clean the extractors.

Robot Part	Care Frequency	Replacement Frequency
Bin	After each use	-
Filter	Once per week (twice per week in homes with pets)	Every 2 months
Brushes	Once per week (twice per week in homes with pets)	Every 6-12 months
Front Caster Wheel	Once every two weeks	Every 12 months
Side Brush Cliff Sensors Charging Contacts	Once per month	



Note: iRobot manufactures various replacement parts and assemblies. Purchase replacement parts through the iRobot HOME App or by visiting www.irobot.com/Roomba600. If you think you need a replacement part, please contact iRobot Customer Care for more information.

Emptying the Bin

- 1 Press the bin release button and pull to remove the bin.

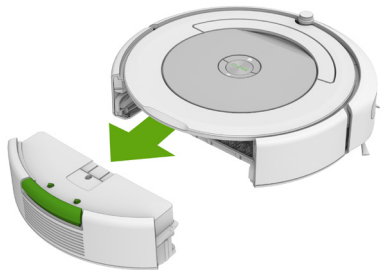

- 2 Open bin door to empty bin.



Cleaning The Filter

- ⚠ Important:** Empty the bin before cleaning the filter.

Pull the filter to remove. Tap the filter against the rubbish container to clear the debris. Reinstall the filter.

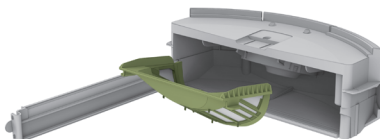

Replace the filter every two months

Cleaning the Brushes

- 1 Open the brush guard by lifting both tabs.

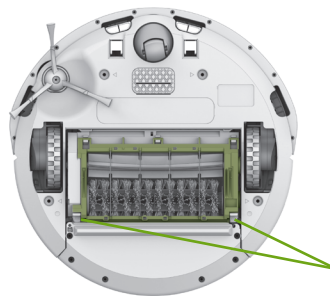

Brush Frame Release Tabs

- 2 Remove and clean any hair and debris from the Brushes and brush bearings.

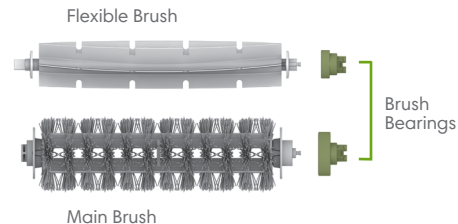

- 3 Reinstall brush bearings and brushes, close brush guard.

Replace the brushes every 6-12 months

Cleaning the Front Caster Wheel

- 1 Pull firmly on the front wheel to remove from the front caster assembly.
- 2 Remove any debris from inside the wheel cavity.
- 3 Spin the wheel by hand. If the rotation is restricted, remove the wheel from its housing and push firmly to remove the axle and clear any debris or hair wrapped around it.
- 4 Reinstall all parts when finished. Make sure the wheel clicks back into place.

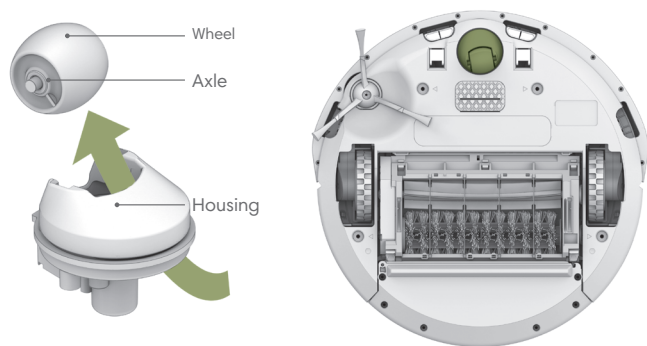

⚠ Important: A front wheel clogged with hair and debris could result in floor damage.

Cleaning the Cliff Sensors and Charging Contacts

Wipe all sensors and charging contacts with a clean, dry cloth.



Cleaning the Side Brush

Use a small screwdriver to remove the screw. Pull the side brush to remove it from the robot. Remove any hair and/or debris and reinstall the side brush.



Troubleshooting

Roomba will tell you something is wrong with a two-tone distress sound followed by a spoken message. The troubleshooting indicator (⚠️) will also blink. More detailed support and videos, are available through the iRobot HOME App as well as online. If the problem is not resolved, visit www.irobot.com/Roomba600.

Rebooting Instructions

For some errors, rebooting Roomba may resolve the problem.

- » To reboot Roomba, press and hold 🏠 (DOCK) and 📍 (SPOT) buttons for 10 seconds until all indicators shut off, then release.
- » When you release the buttons, you will hear an audible tone signifying a successful reboot.

📖 **Note:** If you use Roomba's scheduling feature, open the iRobot HOME App after rebooting to confirm that Roomba's schedule remains intact.

Reduced Power Standby Mode

Roomba consumes a small amount of power any time it is on the Home Base to ensure that it is ready for its next cleaning job as well as to maintain Wi-Fi connectivity. It is possible to put Roomba in a further-reduced power state when not in use. For instructions and more details on this Reduced Power Standby Mode, refer to the iRobot HOME App.

Lithium Ion Battery

(available for select models)

⚠️ **Important:** Lithium ion batteries and products that contain lithium ion batteries are subject to stringent transportation regulations. If you need to ship this product (with the battery included) for service, travel or any other reason, you **MUST** comply with the following shipping instructions:

- » Remove the lithium ion battery from the product
- » Please visit the iRobot HOME App or www.iRobot.com/Roomba600 to view an instructional video on how to remove the battery.
- » Place a piece of tape over the battery's metal charging contacts
- » Reinstall the battery (with the tape on it) in the product and secure the battery door
- » Package the product in its original packaging or in your own packaging that prevents any movement during transportation
- » Ship via ground transportation only (no air shipping)

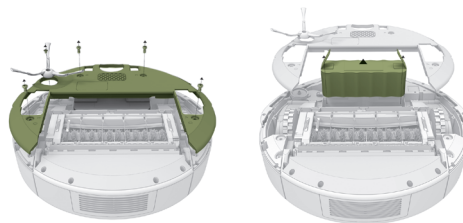

iRobot Customer Care

USA & Canada

If you have questions or comments about your Roomba, please contact iRobot before contacting a retailer. You can also find additional information such as maintenance tips and information about accessories on the iRobot HOME App or on our website at www.irobot.com/Roomba600.

Should you still need assistance, call our Customer Care team at **(877) 855-8593**.

iRobot Customer Care Hours:

- Monday to Friday, 9AM – 7PM Eastern Time
- Saturday, 9AM – 6PM Eastern Time

Outside USA & Canada

Visit global.irobot.com to:

- Learn more about iRobot in your country.
- Get hints and tips to improve your Roomba's performance.
- Get answers to questions.
- Contact your local support center.

Regulatory Information

This device complies with part 15 of the FCC Rules.

Operation is subject to the following two conditions: (1) This device may not cause harmful interference, and (2) this device must accept any interference received, including interference that may cause undesired operation.

- Changes or modifications not expressly approved by iRobot Corporation could void the user's authority to operate the equipment.
- This equipment has been tested and found to comply with the limits for a Class B digital device, pursuant to part 15 of the FCC Rules. These limits are designed to provide reasonable protection against harmful interference in a residential installation. This equipment generates, uses and can radiate radio frequency energy and, if not installed and used in accordance with the instructions, may cause harmful interference to radio communications. However, there is no guarantee that interference to radio communication will not occur in a particular installation. If this equipment does cause harmful interference to radio or television reception, which can be determined by turning the equipment off and on, the user is encouraged to try to correct the interference by one or more of the following measures:
 - Reorient or relocate the receiving antenna.
 - Increase the separation between the equipment and receiver.
 - Connect the equipment into an outlet on a circuit different from that to which the receiver is connected.
 - Consult the dealer or an experienced radio/TV technician for help.
- FCC Radiation Exposure Statement: This product complies with FCC §2.1091(b) for mobile device RF exposure limits, set forth for an

uncontrolled environment and is safe for the intended operation as described in this manual. Per FCC requirements, maintain a distance of more than 8 inches (20cm) between any person and the host device (Roomba robot).

Brazil Radio

This product contains the Azureware AW-CU300 board, approval code 01874-16-03657

Brazil Battery Recycling

Please be sure to dispose the battery properly when necessary. Please discard it at a recycling center or contact our Support Team for more information.

Mexico Radio

This equipment: Robot Vacuum Cleaner; Brand: iRobot; Models 671, 675, 677, 692 and 692 operates with the WiFi Module; Brand Azureware; Model AW-CU300 with IFT Approval Numbers:

- Roomba Model 677 IFT: RCPirro21-4086
- Roomba Model 671 IFT: RCPirro21-4086-A2
- Roomba Model 675 IFT: RCPirro21-4086-A1
- Roomba Models 692 and 694 IFT: RCPAZAW17-0602

For use in Mexico, the operation of this equipment is subject to the following two conditions:

- (1) this equipment or device may not cause harmful interference and
- (2) this equipment or device must accept any interference, including interference that may cause undesired operation.

Argentina Radio

Module Certification: Contains Modula CDC ID: C-16113



©2022 iRobot Corporation, 8 Crosby Drive, Bedford, MA 01730 USA. All rights reserved.

iRobot, Roomba, iAdapt, Home Base and Virtual Wall are registered trademarks of iRobot Corporation. AeroVac and Dirt Detect are trademarks of iRobot Corporation.