

VXA-2 TAPE DRIVE

---

# PRODUCT MANUAL



**COPYRIGHT** Copyright 2002 by Exabyte Corporation. All rights reserved. This item and the information contained herein are the property of Exabyte Corporation. No part of this document may be reproduced, transmitted, transcribed, stored in a retrieval system, or translated into any language or computer language in any form or by any means, electronic, mechanical, magnetic, optical, chemical, manual, or otherwise, without the express written permission of Exabyte Corporation, 1685 38th Street, Boulder, Colorado 80301.

**DISCLAIMER** Exabyte Corporation makes no representation or warranties with respect to the contents of this document and specifically disclaims any implied warranties of merchantability or fitness for any particular purpose. Further, Exabyte Corporation reserves the right to revise this publication without obligation of Exabyte Corporation to notify any person or organization of such revision or changes.

**TRADEMARK NOTICES** Exabyte, Exapak, VXA, and VXAtape are registered trademarks; M2, MammothTape, SmartClean, EZ17 and NetStorM are trademarks; People Working for You and SupportSuite are service marks of Exabyte Corp. All other product names are trademarks or registered trademarks of their respective owners.

**PART NUMBER AND REVISION HISTORY** 1009541-002

<b>Revision</b>	<b>Date</b>	<b>Description</b>
000	March 2002	Preliminary release.
001	June 2002	Initial release.
002	November 2002	Added FireWire information

**NOTE:** The most current information about this product is available at Exabyte's World Wide Web site ([www.exabyte.com](http://www.exabyte.com)).

**PRODUCT  
WARRANTY  
CAUTION**

The Exabyte VXA-2 tape drive is warranted to be free from defects in materials, parts, and workmanship, and conforms to the current product specification. For the specific details of your warranty, refer to your sales contract or contact the company from which you purchased the tape drive.

The warranty for the tape drive shall not apply to failures caused by:

- ▶ Physical abuse or use not consistent with the operating instructions or product specifications.
- ▶ Use of any type of data cartridge other than an Exabyte VXAtape or an Exabyte-approved VXAtape cartridge.
- ▶ Use of any type of cleaning material other than an Exabyte VXAtape Cleaning Cartridge.
- ▶ Repair or modification by any one other than Exabyte's personnel or agent in a manner differing from the maintenance instructions provided by Exabyte.
- ▶ Removal of the Exabyte identification label(s).
- ▶ Physical abuse due to improper packaging of returned drives.

If problems with the tape drive occur, contact Exabyte or your service provider; do not void the product warranty by allowing untrained or unauthorized personnel to attempt repairs.



**Caution**

Returning the tape drive in unauthorized packaging may damage the unit and void the warranty.

If you are returning the tape drive for repair, package it in its original packaging (or in replacement packaging obtained from your vendor).

---

**CONTACTING  
EXABYTE**

<b>To obtain general information</b>	
Corporate Headquarters	Exabyte Corporation 1685 38th Street Boulder, CO USA 80301
	(303) 442-4333
<b>To obtain technical support</b>	
Exabyte Technical Support	1-303-417-7792
	1-303-417-7190 (fax)
World Wide Web	<a href="http://www.exabyte.com">www.exabyte.com</a>
<b>To order supplies and accessories</b>	
Exabyte Sales Support	1-800-774-7172
	1-800-392-8273 (Exabyte Media)
<b>To return equipment for service</b>	
Exabyte Service	1-303-417-7791 (US)
	Teleplan-800-673-5719 (Canada)
	1-303-417-7199 (fax)

**Note:** If it is more convenient to your location, contact Exabyte Technical Support in Europe at the following numbers:

Phone: +31-30-254-8890

Fax: +31-30-258-1582



# Contents

<b>How to Use This Manual</b> .....	<b>ix</b>
<b>1 VXA-2 Features</b> .....	<b>1-1</b>
Drive Models and Interfaces .....	1-1
Components.....	1-2
Front Panel Components.....	1-2
Back Panel Components – Internal Drive .....	1-3
Back Panel Components – External Drive .....	1-4
Drive Labels.....	1-5
<b>2 Installation</b> .....	<b>2-1</b>
Unpacking the Tape Drive.....	2-1
Installing the Tape Drive .....	2-1
Installing the Internal Model in an Enclosure.....	2-2
Before You Begin.....	2-2
Install the Tape Drive.....	2-3
Installing the External SCSI Tape Drive .....	2-7
Before You Begin.....	2-7
Install the Tape Drive.....	2-8
Installing the External FireWire Tape Drive .....	2-9
Before You Begin.....	2-9
Install the Tape Drive.....	2-10
Integrating the Tape Drive .....	2-11

<b>3</b>	<b>Operation . . . . .</b>	<b>3-1</b>
	Monitoring the LEDs . . . . .	3-2
	Using VXAtape Cartridges . . . . .	3-3
	Setting the Write-Protect Switch . . . . .	3-4
	Loading a Cartridge . . . . .	3-4
	Unloading a Cartridge . . . . .	3-4
	Cartridge Storage Guidelines . . . . .	3-4
	Cleaning the Tape Drive . . . . .	3-5
	Determining When to Clean the Tape Drive . . . . .	3-5
	Using a Cleaning Cartridge . . . . .	3-6
	Resetting the Tape Drive . . . . .	3-6
<b>4</b>	<b>Troubleshooting . . . . .</b>	<b>4-1</b>
	Problems and Solutions . . . . .	4-1
	Tape Drive Will Not Accept a Cartridge . . . . .	4-1
	LED 4 is Orange . . . . .	4-2
	Tape Drive Will Not Eject a Cartridge . . . . .	4-2
	The Operating System or Application Software Does Not “See” the Tape Drive . . . . .	4-3
	A Service Notification LED Code Appears . . . . .	4-4
	Backup Software is Reporting an Error . . . . .	4-5
	Troubleshooting with VXA2Tool . . . . .	4-6
<b>5</b>	<b>Service and Maintenance . . . . .</b>	<b>5-1</b>
	Returning the Tape Drive for Service . . . . .	5-1
	Upgrading Firmware . . . . .	5-2
	Obtaining a Diagnostic Listing . . . . .	5-2
<b>6</b>	<b>Overview of the SCSI Command Protocol . . . . .</b>	<b>6-1</b>
	Communication Interface versus Command Protocol . . . . .	6-1
	SCSI-2 Command Protocol . . . . .	6-2
	Command Set . . . . .	6-2
	Status Bytes . . . . .	6-4
	Sense Keys . . . . .	6-4
	SCSI Messages . . . . .	6-6

<b>7</b>	<b>Overview of the Communication Interface . . . . .</b>	<b>7-1</b>
	SCSI Interface Requirements.....	7-1
	Internal Model .....	7-2
	SCSI Cable Requirements .....	7-2
	SCSI Connector Requirements.....	7-3
	SCSI Terminator Requirements .....	7-4
	External Drive .....	7-4
	SCSI Cable Requirements .....	7-4
	SCSI Terminator Requirements .....	7-4
	FireWire Interface Cable and Connector Specifications.....	7-4
<b>8</b>	<b>Specifications. . . . .</b>	<b>8-1</b>
	Data Capacities .....	8-1
	Performance Specifications.....	8-2
	Data Transfer Rates .....	8-2
	Read and Write Specifications.....	8-2
	Tape Speed and Access time .....	8-3
	Reliability Specifications .....	8-3
	Size and Weight .....	8-4
	Power Specifications.....	8-5
	Internal Drive.....	8-5
	Power Connector Pin Assignments.....	8-5
	DC Voltages .....	8-6
	Power Consumption .....	8-7
	External Drive .....	8-7
	Power Supply .....	8-7
	Power Consumption .....	8-7
	Environmental Specifications .....	8-8
	Environmental Conditions for the Tape Drive .....	8-8
	Internal Tape Drive: Operating Temperature and Humidity	8-8
	External Tape Drive: Operating Temperature and Humidity	8-9
	Air Flow Requirements .....	8-10
	Particulate Contamination Limits .....	8-11
	Acoustic Noise.....	8-11
	Shock Specifications .....	8-11
	Vibration Specifications .....	8-12
	Environmental Conditions for the VXAtape Cartridges .....	8-13

Packaging and Shipping Specifications..... 8-14  
    Shipping Cartons ..... 8-14  
    Packaging Materials ..... 8-14  
Safety and Regulatory Compliance ..... 8-15  
    Underwriters Laboratory ..... 8-15  
    TUV Product Service ..... 8-15  
    United States: FCC Declaration of Conformity ..... 8-16  
    Canadian Verification ..... 8-16  
    European Community..... 8-16  
    Japan..... 8-16  
    Australia and New Zealand ..... 8-17  
    Taiwan ..... 8-17

**Glossary ..... G-1**

**Index ..... I-1**

## HOW TO USE THIS MANUAL

This manual describes how to install, operate, and maintain the VXA™-2 tape drive. It also provides functional, performance, and environmental specifications.

### ORGANIZATION

The information in this manual is organized into chapters that allow you to quickly locate the information you need.

#### First-time installation

If you are installing the tape drive for the first time, refer to the following chapters:

- ▶ **Chapter 1** provides an overview of the tape drive's features and components.
- ▶ **Chapter 2** provides instructions for installing the tape drive, connecting it to the host computer, and powering it on.

#### Operation, troubleshooting, maintenance, and service

Refer to these chapters for information about operating, maintaining, and troubleshooting your tape drive:

- ▶ **Chapter 3** to learn how to load cartridges, clean the tape drive, and read the LEDs.
- ▶ **Chapter 4** provides troubleshooting recommendations.
- ▶ **Chapter 5** provides information about service and maintenance for the tape drive, including returning it for service, upgrading firmware, and obtaining a diagnostic listing.

#### Specifications, standards, and terms

These chapters are for engineering, purchasing, or marketing personnel who want to evaluate the tape drive to determine the feasibility of integrating it into their product lines.

- ▶ **Chapter 6** provides an overview of the SCSI command protocol supported by the tape drive.
- ▶ **Chapter 7** describes the communication interface specifications for the tape drive, including cable and connector requirements for the LVD SCSI and FireWire interfaces.
- ▶ **Chapter 8** provides specifications for the tape drive, including performance, reliability, power, and environmental specifications. This chapter also provides safety and regulatory agency standards compliance information.
- ▶ The **Glossary** provides definitions of terms used in this book.

## RELATED PUBLICATIONS

For more information about the tape drive and the standards used by the tape drive, refer to the following publications. To order an Exabyte publication, see **“Contacting Exabyte” on page iv**. To download a PDF version of an Exabyte publication, visit the Exabyte web site ([www.exabyte.com](http://www.exabyte.com)).

**NOTE:** The VXA-2 publications are included as PDF files on the CD that accompanies your tape drive.

### VXA-2 Publications

- ▶ *VXA-2 SCSI Reference Manual*, 1009566
- ▶ *VXA-2 SCSI Tape Drive Quick Start*, 1009540
- ▶ *VXA-2 FireWire Tape Drive Quick Start*, 1011098

### Standards Publications

- ▶ *ANSI Small Computer System Interface (SCSI-2)*, X3.131-1994
- ▶ *Information Technology—Serial Bus Protocol 2 (SBP-2)*, ANSI NCITS 325:1998
- ▶ *IEEE Standard for a High Performance Serial Bus*, IEEE 1394a-1995
- ▶ *Information Technology—Microprocessor Systems—IEEE Standard Control and Status Register (CSR) Architecture for Microcomputer Buses*, ISO/IEC 13213:1994

## CONVENTIONS USED IN THIS MANUAL

This manual uses the following conventions:

**NOTE:** Notes provide additional information or suggestions about the topic or procedure being discussed.

---

**! Tip** Read information marked by the “Tip” icon for information that will help you complete a procedure or avoid extra steps.

---

---

**! Important** Read information marked by the “Important” icon for information that will help you avoid future problems.

---



### Caution

Read the information marked by the “CAUTION” icon for information you must know to avoid damaging the tape drive or losing data.

---

---

# VXA-2 FEATURES

This chapter describes the VXA-2 tape drive features and components. The VXA-2 tape drive is designed for the storage and management of enterprise-wide, mission-critical data. The VXA-2 tape drive is capable of storing 80 gigabytes (GB) of native data on a 230-meter VXA tape. It can transfer data at a sustained rate of 6 megabytes (MB) per second and is backward compatible with the first-generation VXA-1 tape drive.

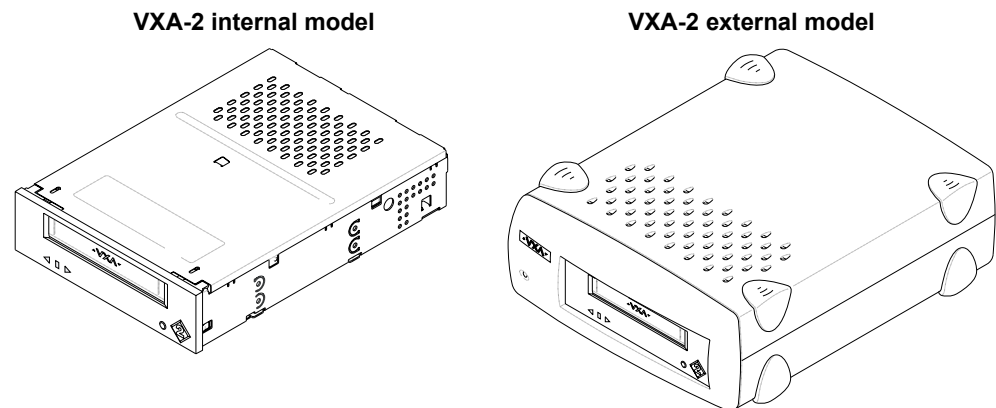

**Figure 1-1** VXA-2 tape drives (internal and external models)

## DRIVE MODELS AND INTERFACES

For simple and convenient system integration, the VXA-2 tape drive is available in external and internal models. The internal VXA-2 complies with industry standard 5.25-inch half-high form factor mounting requirements and can be mounted horizontally or vertically. The external standalone model is housed in an enclosure that allows the device to be placed horizontally or vertically on a flat surface. External models can also be stacked. Neither model can be installed upside down.

The VXA-2 tape drive is available with a wide, Ultra2 SCSI low-voltage differential (LVD) interface. The external model of the tape drive is also available with a FireWire interface.

## COMPONENTS

This section describes the major components of the tape drive.

### FRONT PANEL COMPONENTS

Figure 1-2 and Figure 1-3 show the controls and indicators on the front panel of the tape drive. For more information about using these controls and indicators, see Chapter 3.

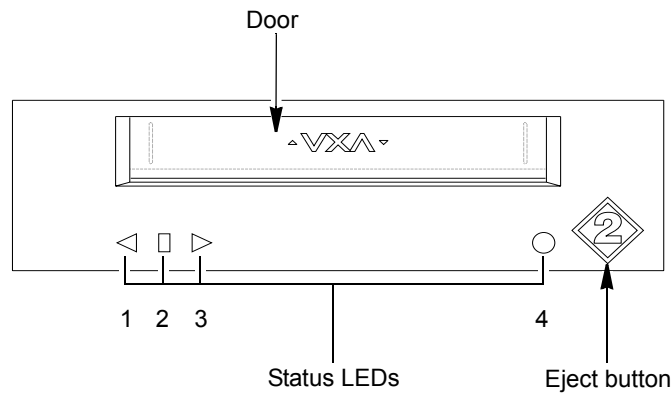

Figure 1-2 Internal drive: front-panel components

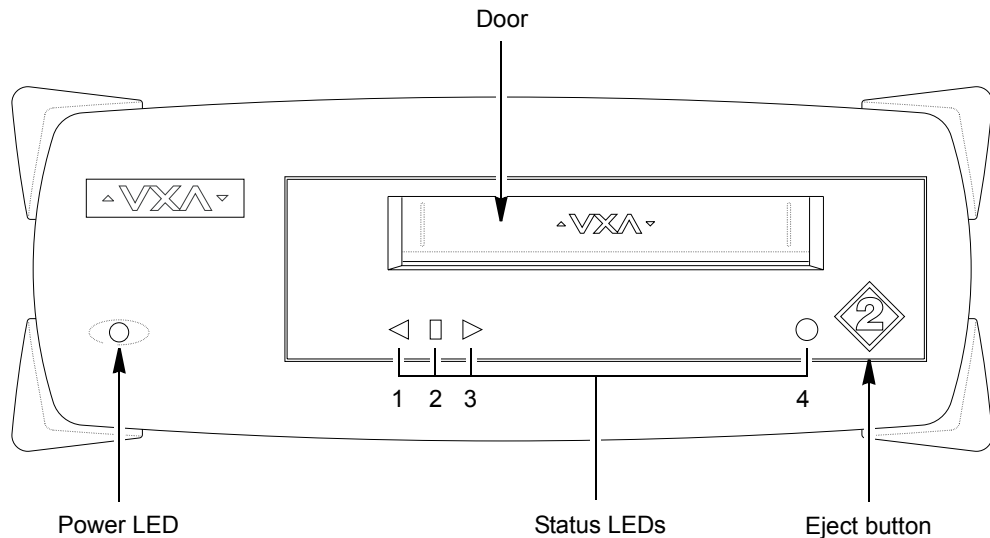

Figure 1-3 External drive: front-panel components

**Door** Used for inserting the cartridge into the tape drive.

**Eject Button** Used to unload the tape and eject the cartridge.

**Status LEDs (Light Emitting Diodes)** Show status information, which is described in “Monitoring the LEDs” on page 3-2.

**Power LED** Shows the power-on status of the external tape drive.

## BACK PANEL COMPONENTS – INTERNAL DRIVE

Figure 1-4 shows the back panel components of the internal SCSI drive. For more information about using these components during installation, see Chapter 2.

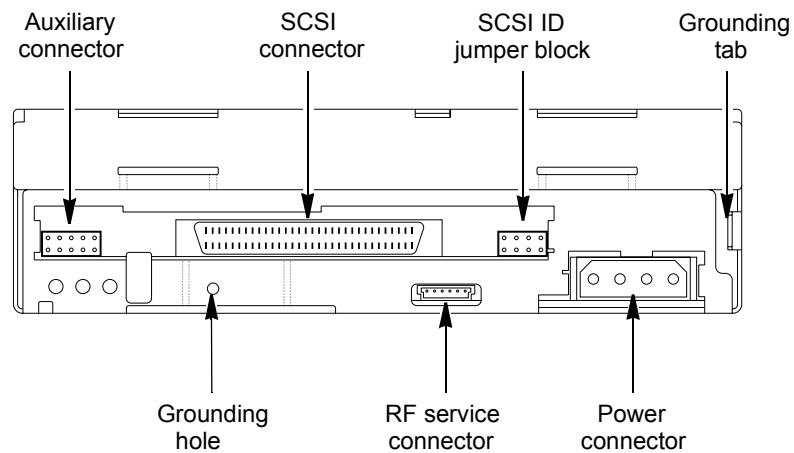

**Figure 1-4** Internal SCSI drive: back-panel components

**Auxiliary Connector** Used to enable term power (see page 2-4).

**SCSI Connector** Used to connect the tape drive to the SCSI bus. This is a standard 68-pin wide, Ultra2 SCSI LVD connector. (See Table 7-2 for pin assignments.)

**SCSI ID Jumper Block** Used to set the SCSI ID.

**Grounding Tab and Hole** Used to provide additional chassis grounding. (The mounting screws also provide grounding for the tape drive.)

**RF Service Connector** Used for Exabyte Service only.

**Power Connector** Used to connect a power cable from the enclosure's power supply. This is a 4-pin connector. (See Table 8-7 for pin assignments.)

## BACK PANEL COMPONENTS – EXTERNAL DRIVE

Figure 1-5 shows the back-panel components of the external SCSI model of the tape drive. Figure 1-6 shows the back-panel components of the external FireWire model of the tape drive

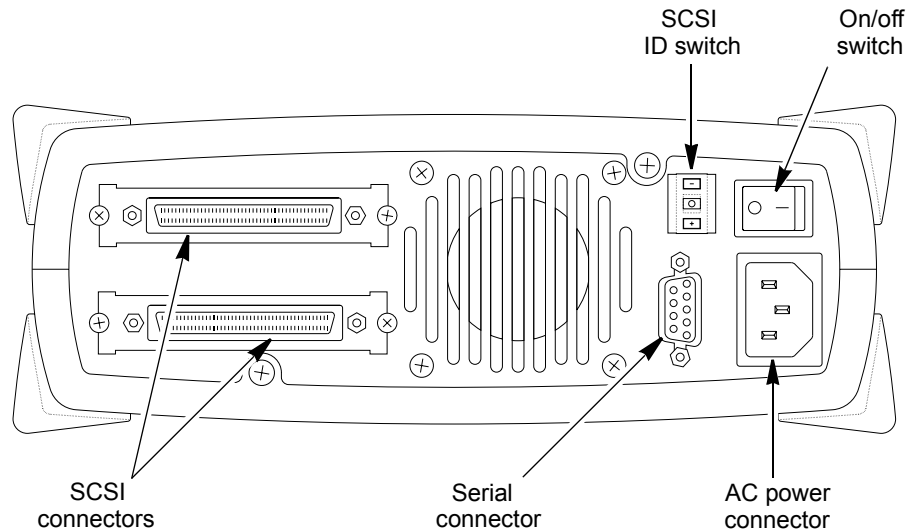

Figure 1-5 External SCSI drive: back-panel components

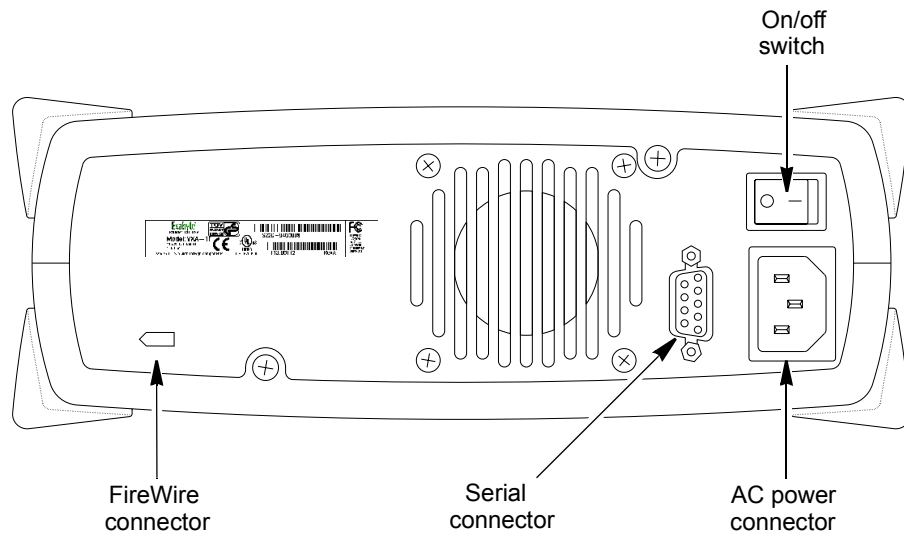

Figure 1-6 External FireWire drive: back-panel components

**On/Off Switch** Used to turn power on and off.

**AC Power Connector** Used to provide power through a grounded AC power connector. A power cord is included with the tape drive.

**Serial Connector** Diagnostic port (see page 4-6).

**SCSI Connectors (SCSI tape drive only)** Used to connect the tape drive to the SCSI bus with two SCSI cables or one SCSI cable and a terminator. These connectors are 68-pin, wide, Ultra2 LVD connectors.

**SCSI ID Switch (SCSI tape drive only)** Used to set the SCSI ID.

**FireWire Connector (FireWire tape drive only)** Used to connect the tape drive to the host system FireWire controller.

**DRIVE LABELS**

The VXA-2 tape drive includes two labels that show the tape drive’s part number, serial number, revision, connector type, and agency information (see **Figure 1-7** and **Figure 1-8** for examples). Depending on the model tape drive you have, the labels on your tape drive may differ.



**Caution**

Do not remove or modify these labels. If you do so, you will void the product warranty.



**Figure 1-7** Back-panel label (SCSI tape drive)

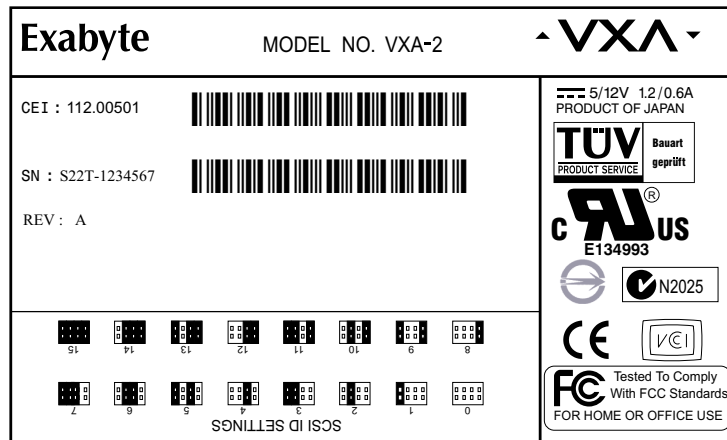

**Figure 1-8** Top-panel label (SCSI tape drive)

## **Notes**

# 2

## INSTALLATION

This chapter provides step-by-step instructions for installing the internal and external models of the VXA-2 tape drive. The information in this chapter supplements the instructions in the *Quick Start* guide that accompanied your tape drive.

### UNPACKING THE TAPE DRIVE

All Exabyte tape drives are tested, inspected, and carefully packaged at the factory. However, because shipping damage can occur, you should follow the steps below to unpack the tape drive:

1. Visually inspect the shipping container and notify your freight carrier immediately if you see any damage.
2. Place the shipping container on a flat, clean, stable surface. If parts are missing or the equipment is damaged, notify your supplier or Exabyte.
3. Save the original shipping container and packaging materials in case you need to reship the tape drive.

### INSTALLING THE TAPE DRIVE

The installation instructions for your tape drive depend on what model you have:

- ▶ If you are installing the internal model in an enclosure, follow the steps beginning on [page 2-2](#).
- ▶ The external model of the VXA-2 tape drive is available with either an LVD SCSI interface or a FireWire interface. If you are installing the external SCSI model, follow the steps beginning on [page 2-7](#). If you are installing an external FireWire model, follow the steps beginning on [page 2-9](#).

## INSTALLING THE INTERNAL MODEL IN AN ENCLOSURE

The internal tape drive complies with industry-standard, 5.25-inch half-high form factor mounting requirements and can be mounted either horizontally or vertically, but not upside down.

When installing the tape drive, refer to [Figure 2-1](#) for the location of the back-panel components on the SCSI tape drive.

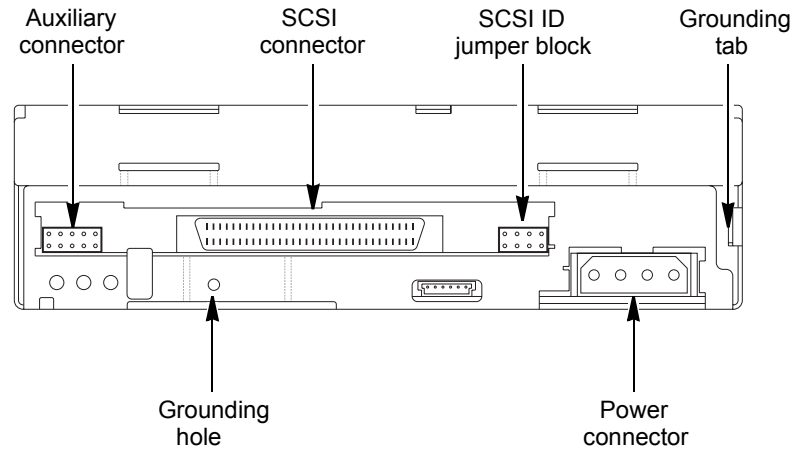

**Figure 2-1** Internal SCSI drive: back-panel components

### Before You Begin

Before you begin hardware installation, do the following:

- ✓ **Select your application software** — To obtain information about which software applications work with the tape drive, visit Exabyte's web site ([www.exabyte.com](http://www.exabyte.com)). You can install the software application on the host computer before or after you install the tape drive. However, if you install the software first, you may need to reconfigure it for use with the tape drive.
- ✓ **Install an LVD SCSI host bus adapter** — Make certain the SCSI host bus adapter card installed in the host computer is LVD and compatible with the tape drive. Exabyte does not recommend connecting the tape drive to a RAID controller.

---

**! Important** To avoid SCSI bus hangs, do not connect the tape drive to an HVD SCSI bus. To avoid performance problems, do not connect the tape drive to a single-ended SCSI bus.

---

- ✓ **Protect the work area from ESD** — Touch a known grounded surface to discharge static electricity from your body and ensure that the work area is free from conditions that could cause ESD.

## Install the Tape Drive

### 1. Power down the computer system.

Turn off all devices attached to the computer in which you plan to install the tape drive, then turn off the computer. Disconnect all power cables.

### 2. Prepare the drive bay.

Remove the drive bay's cover plate according to the system manufacturer's instructions.

### 3. Set the SCSI ID and termination (term) power jumpers, if necessary.

- a. The tape drive is shipped with a SCSI ID of 11. If another device on the SCSI bus is already configured with this SCSI ID, you will need to change the tape drive's SCSI ID. Reposition the jumpers on the jumper block, as shown in [Figure 2-2](#), to select the desired ID. (If necessary, use flat-nose pliers to remove the jumpers.) If you need an additional jumper, use a 2 mm jumper.

Alternatively, you can remove the jumpers and connect a cable (not included) from a remote switch to the jumper block, then use the remote switch to set the SCSI ID. The cable should use a connector equivalent to Hirose Housing part number DF11-8DS-2C, 2.0MM 8CKT to connect to the jumper block.

---

**! Important** Each device on the SCSI bus must have a unique SCSI ID.

---

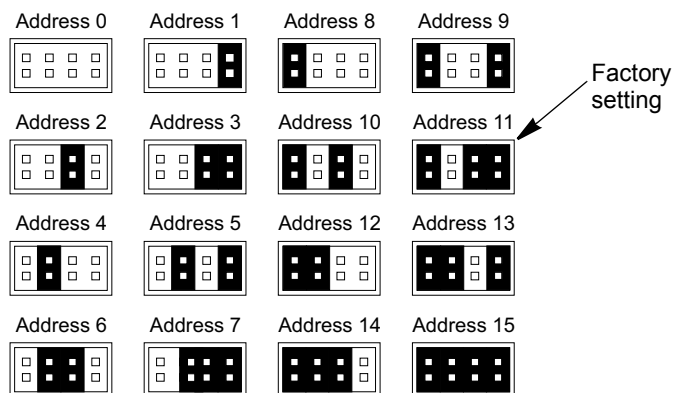
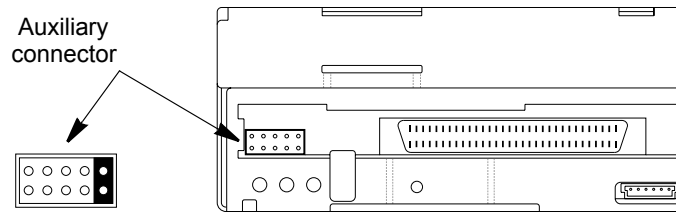

**Figure 2-2** SCSI ID settings

- b. Set SCSI termination (term) power, if necessary.

You can use the auxiliary connector to enable the terminator power signal. (The tape drive is shipped from the factory with termination power disabled.) To enable termination power, place a jumper across the far right pins on the auxiliary connector, as shown in [Figure 2-3](#). Make sure the jumper is firmly in place. Use a 2 mm jumper.

**NOTE:** To protect the tape drive components if term power is shorted, the tape drive includes a self-resetting power fuse.



**Figure 2-3** Term power enabled

4. Provide additional grounding, if desired.

Attaching the tape drive to the enclosure protects the tape drive from ESD. However, if you want additional chassis grounding for the tape drive, use the grounding hole or grounding tab on the back panel (see [Figure 2-1](#)):

- ▶ Connect an M3 (0.25 in.) female spade connector from the host to the tape drive's grounding tab.

or

- ▶ Use an M3 x 0.5 mm x 4 mm machine screw to connect a grounding wire to the grounding hole.



### Caution

Do not use a screw other than the type specified for attaching the grounding wire, or you may damage the internal components.

5. Connect the SCSI cable.

Connect one of the enclosure's internal SCSI cables to the SCSI connector on the back of the tape drive (see [Figure 2-4](#)). This cable must be shielded and must meet the guidelines in "SCSI Cable Requirements," beginning on [page 7-2](#).

**NOTE:** If desired, you can mount the tape drive (see [page 2-6](#)) before you connect the SCSI cable and the power cable to the back. However, if the cables are difficult to access in the enclosure, you should extend the cables out through the drive bay and connect them before mounting the tape drive.

**Caution**

To avoid damaging the tape drive, make certain you connect pin 1 on the cable to pin 1 on the tape drive. Pin 1 is on the right, top row of the connector pins (see Figure 2-1).

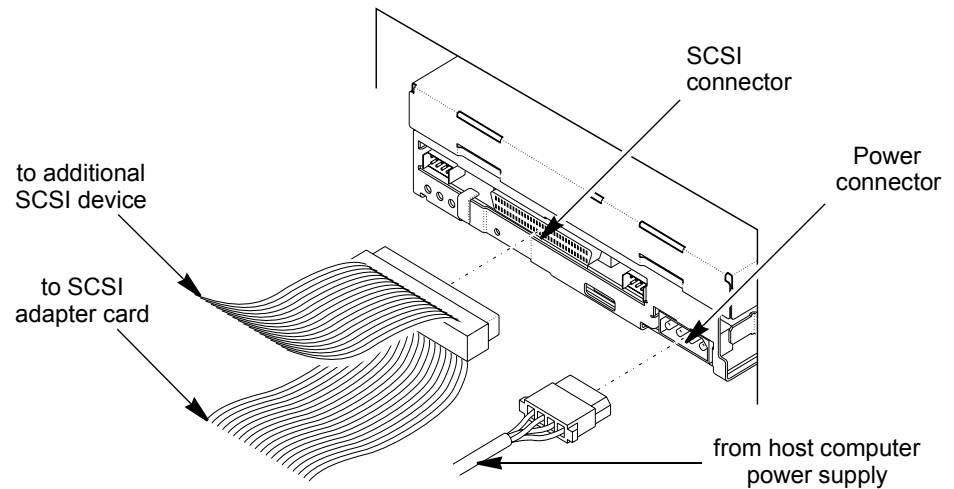
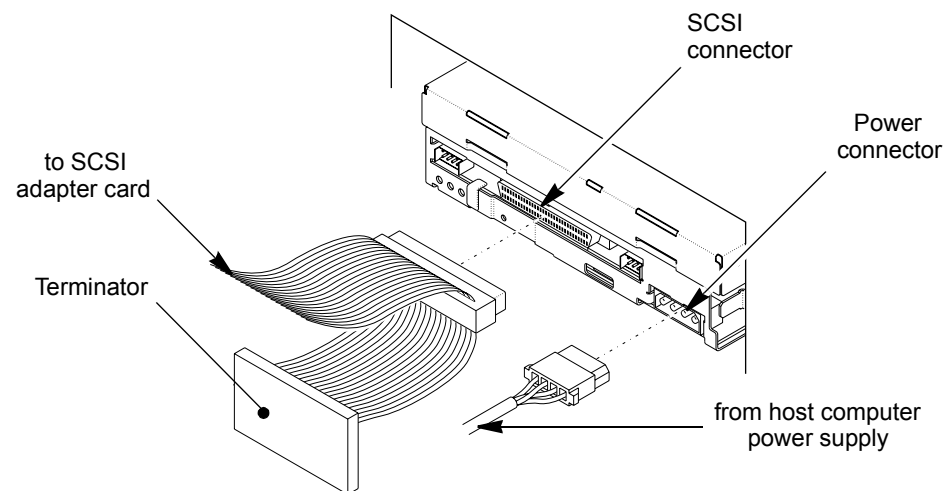

**Figure 2-4** Connecting the SCSI cable and power cable (another device is the last device on the bus)

**6.** Install a terminator at the physical end of the SCSI bus.

If the tape drive is the last device on the SCSI bus and if the SCSI cable has an unused connector at the end, you can terminate the bus there, as shown in Figure 2-5. Alternatively, you can terminate the bus by installing a pass-through terminator on the tape drive's SCSI connector.

If there are additional devices on the SCSI bus, ensure that only the device at the physical end of the bus is terminated.



**Figure 2-5** Connecting a SCSI cable (tape drive is last device on the bus)

### 7. Connect the power cable.

Locate the enclosure's internal power cable and connect it to the tape drive's power connector, as shown in [Figure 2-4](#) or [Figure 2-5](#). The enclosure's power cable connector must be an AMP 1-480424-0 series, or equivalent.

For the pin assignments of the tape drive's power connector, see [Table 8-7](#) on [page 8-5](#).

### 8. Mount the tape drive in the drive bay.

Slide the tape drive into the bay. Ensure that no cables are caught or crimped between the tape drive and the chassis. Using the screws provided with the tape drive, secure the tape drive in the drive bay using one of the screw mounting combinations (see [Figure 2-6](#)).



### Caution

To avoid damaging the tape drive, follow these precautions:

- ▶ Use only the M3 x 0.5 x 4 mm Phillips screws.
- ▶ Ensure that the chassis is not distorted. (Alignment to the horizontal or vertical plane should not exceed  $\pm 10^\circ$ .)
- ▶ Ensure that no objects (screw heads, cables, or adjacent devices) are pressing against the frame.
- ▶ Do not use a combination of the two sets of mounting holes.
- ▶ Do not obstruct the tape drive's ventilation slots (top and rear).

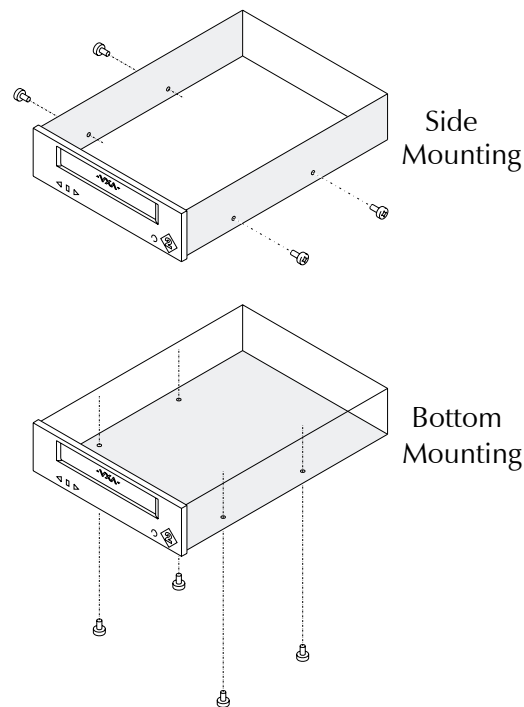
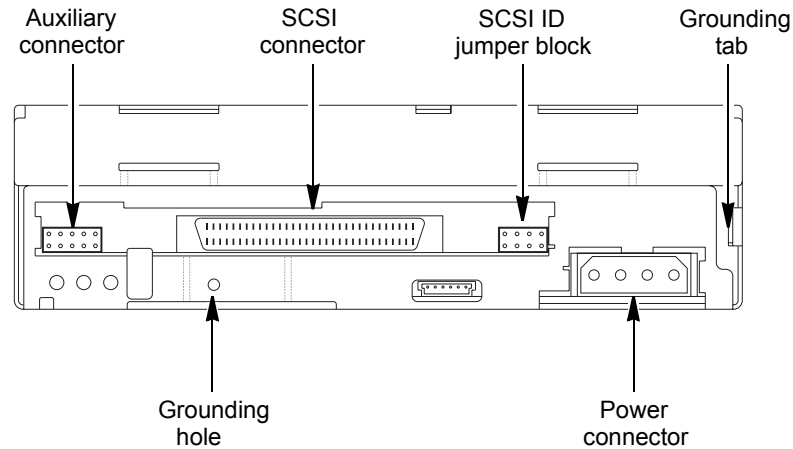

**Figure 2-6** Screw mounting configurations (internal model)

## INSTALLING THE INTERNAL MODEL IN AN ENCLOSURE

The internal tape drive complies with industry-standard, 5.25-inch half-high form factor mounting requirements and can be mounted either horizontally or vertically, but not upside down.

When installing the tape drive, refer to [Figure 2-1](#) for the location of the back-panel components on the SCSI tape drive.



**Figure 2-1** Internal SCSI drive: back-panel components

### Before You Begin

Before you begin hardware installation, do the following:

- ✓ **Select your application software** — To obtain information about which software applications work with the tape drive, visit Exabyte's web site ([www.exabyte.com](http://www.exabyte.com)). You can install the software application on the host computer before or after you install the tape drive. However, if you install the software first, you may need to reconfigure it for use with the tape drive.
- ✓ **Install an LVD SCSI host bus adapter** — Make certain the SCSI host bus adapter card installed in the host computer is LVD and compatible with the tape drive. Exabyte does not recommend connecting the tape drive to a RAID controller.

---

**! Important** To avoid SCSI bus hangs, do not connect the tape drive to an HVD SCSI bus. To avoid performance problems, do not connect the tape drive to a single-ended SCSI bus.

---

- ✓ **Protect the work area from ESD** — Touch a known grounded surface to discharge static electricity from your body and ensure that the work area is free from conditions that could cause ESD.

## Install the Tape Drive

1. Power down the host computer system.

Turn off all devices attached to the computer to which you plan to connect the tape drive, then turn off the computer. Disconnect all power cables.

2. Set the SCSI ID.

The tape drive is shipped with a SCSI ID of 11. If another device on the SCSI bus is already configured with this SCSI ID, you will need to change the tape drive's SCSI ID. To change the default ID, press the + and – tabs above and below the SCSI ID indicator until the desired SCSI ID appears.

3. Connect the SCSI cable.

Connect a SCSI cable from the host computer system to the back of the tape drive. Make sure the cable is a wide Ultra2 SCSI LVD cable with a 68-pin, high-density male connector. See [Table 7-3](#) for cable specifications.



### Caution

Do not use a noncompliant SCSI cable; it will degrade VXA-2 performance and can cause random, nonreproducible errors. See [Table 7-3](#) for cable specifications.

4. Install a terminator at the physical end of the SCSI bus.

If the tape drive is the last device on the bus, install a terminator on the unused SCSI connector, as shown in [Figure 2-8](#).

If there are additional devices on the SCSI bus, ensure that only the device at the physical end of the bus is terminated.

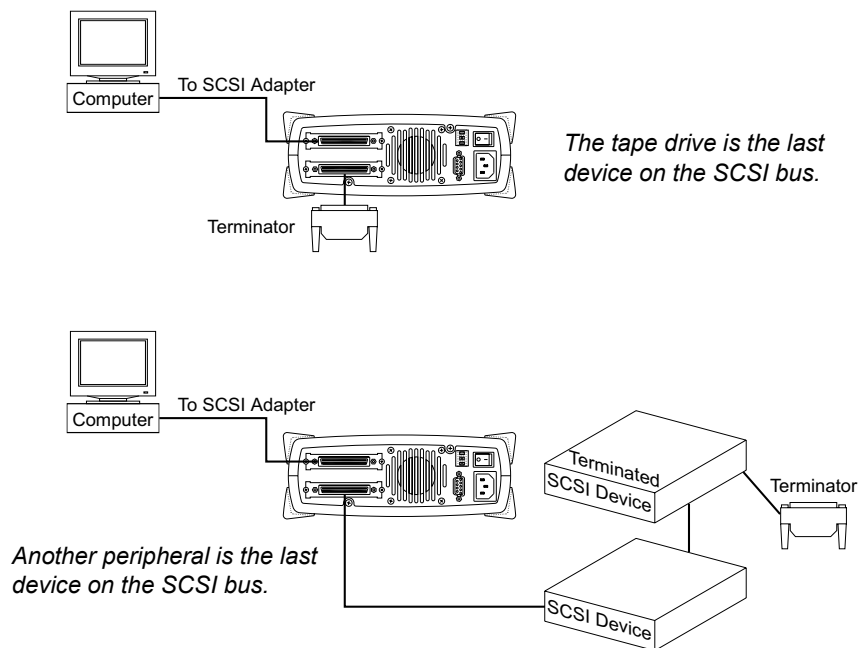

**Figure 2-8** Terminating the SCSI bus for the external model

5. Connect the power cable and turn on the power.

Connect the power cable to the back of the tape drive. Turn on the tape drive's power switch. During the tape drive's power-on self-test (POST), the LEDs scroll sequentially right to left, then left to right in yellow and green. LED 4 illuminates in red and green. When POST is complete, LED 4 illuminates in green. (See [Table 3-1, "LED states,"](#) on [page 3-2](#) for a description of the LED states.)

6. Power on the host computer system.

## INSTALLING THE EXTERNAL FIREWIRE TAPE DRIVE

When installing the external FireWire tape drive, refer to [Figure 2-9](#) for the location of the back-panel components.

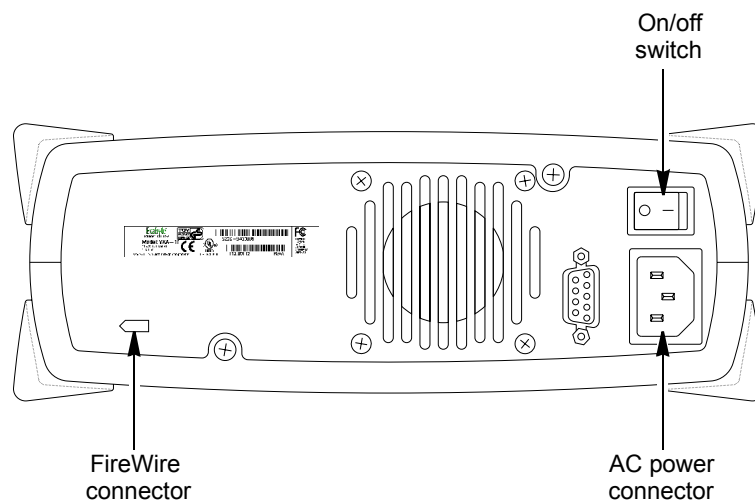

**Figure 2-9** External FireWire drive: back-panel components

### Before You Begin

Before you begin hardware installation, do the following:

- ✓ **If you are using a Windows® PC** — Make sure that your system is equipped with a 6-conductor IEEE 1394/FireWire controller with at least one free port. If you plan to use an iLink port, obtain a 4-conductor to 6-conductor converter. This converter is typically supplied with the IEEE 1394/FireWire controller.

---

**! Important** Only Windows XP, Windows 2000, Windows ME, and Win98 SE support FireWire (IEEE 1394) devices. If you are using an earlier version of Windows, you must upgrade your operating system if you want to use the VXA-2 FireWire tape drive.

---

- ✓ **If you are using Macintosh® OS 9** — Determine the version of FireWire on your system. If necessary update your FireWire version, as follows:
  - a. Click on the *Apple* icon in the upper left of your screen.
  - b. Highlight *Control Panels*.
  - c. Click on the *Extensions Manager*.
  - d. Scroll down the *Extensions Manager* and find *FireWire Support*. The version must be 2.33 or higher.
  - e. If necessary, download the latest version of FireWire support from the URL <http://asu.info.apple.com/>
  - f. Install or update FireWire support by clicking on the *FireWire* icon created by the download.
- ✓ **Install your application software** — To obtain information about which software applications work with the tape drive, visit Exabyte's web site ([www.exabyte.com](http://www.exabyte.com)). You can install the software application on the host computer before or after you install the tape drive. However, if you install the software first, you may need to reconfigure it for use with the tape drive.
- ✓ **Protect the work area from ESD** — Touch a known grounded surface to discharge static electricity from your body and ensure that the work area is free from conditions that could cause ESD.

### Install the Tape Drive

1. Power down the host computer system.

Turn off all devices attached to the computer to which you plan to connect the tape drive, then turn off the computer. Disconnect all power cables.

2. Connect the FireWire cable to the back of the tape drive.
3. Connect the power cable to the back of the tape drive and turn on the power.

Connect the power cable to the back of the tape drive. Turn on the tape drive's power switch. During the tape drive's power-on self-test (POST), the LEDs scroll sequentially right to left, then left to right in yellow and green. LED 4 illuminates in red and green. When POST is complete, LED 4 illuminates in green. (See [Table 3-1, "LED states,"](#) on [page 3-2](#) for a description of the LED states.)

4. Connect the FireWire cable to your system.
5. Power on the host computer system.

## INTEGRATING THE TAPE DRIVE

After installing the VXA-2 tape drive, you may need to integrate it with your backup application and computer operating system. The CD included with the tape drive provides device drivers for use with several computer operating systems. For additional information, the Support section of Exabyte's web site, [www.exabyte.com](http://www.exabyte.com), provides a list of software applications and operating systems that are compatible with the VXA-2 tape drive.

If your application software does not support the VXA-2 tape drive but does support the VXA-1 tape drive, Exabyte provides tools to change the product identification information that the tape drive returns to the software. Changing the tape drive's identification information to VXA-1 does not affect the tape drive's speed or capacity. An FAQ on Exabyte's web site at [www.exabyte.com](http://www.exabyte.com) provides more information.

## Notes

## OPERATION

This chapter describes how to operate the tape drive. **Figure 3-1** and **Figure 3-2** show the controls and indicators on the front panel of the tape drive.

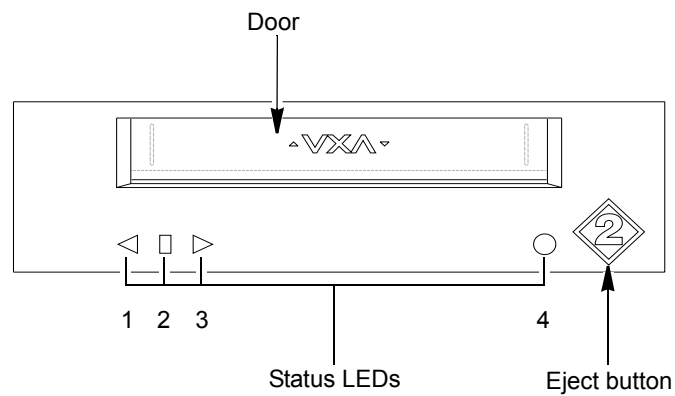

**Figure 3-1** Internal drive: front-panel components

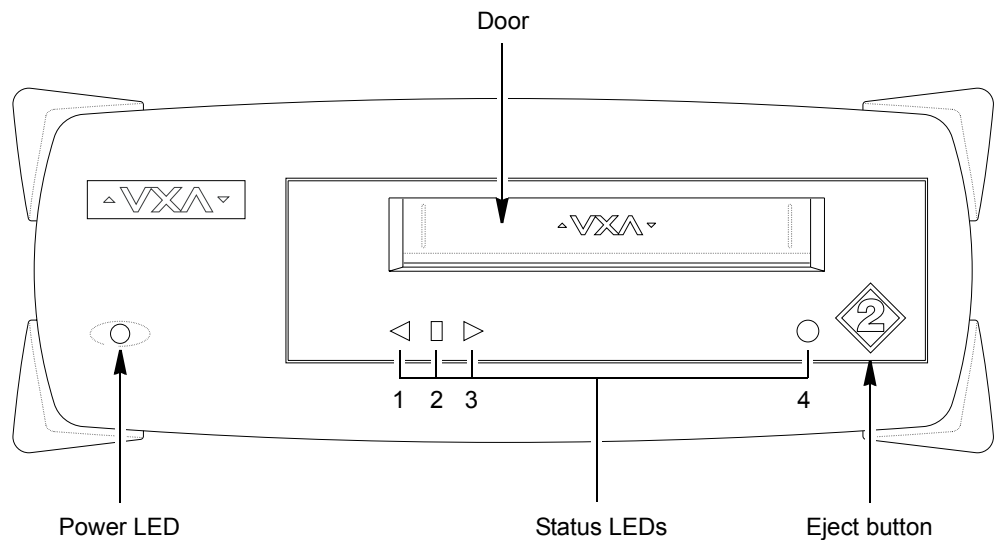

**Figure 3-2** External drive: front-panel components

## MONITORING THE LEDs

The VXA-2 tape drive uses four LEDs to indicate its operational status, as shown in [Table 3-1](#).

**Table 3-1** LED states

Operation	LED Pattern	LED #1 ◁	LED #2 □	LED #3 ▷	LED #4 ○
<b>Operational Conditions</b>					
Power-on self-test	(LEDs illuminate sequentially) <sup>a</sup>				
No tape loaded	◁ □ ▷ ●	Off	Off	Off	Green
SCSI activity; (LED 4 may flash with other LED operations)	◁ □ ▷ ●	Off	Off	Off	Flashing Green
Tape loading or unloading	◁ ▬ ▷ ○	Off	Flashing Green	Off	Off
Tape ready; idle	◁ ▬ ▷ ○	Off	Green	Off	Off
Reading	◁ □ ▬ ●	Off	Off	Green	Flashing Green
Writing	◁ □ ▬ ●	Off	Off	Yellow	Flashing Green
Space forward	◁ □ ▬ ○	Off	Off	Flashing Green	Off
Space reverse or rewinding	▬ □ ▷ ○	Flashing Green	Off	Off	Off
Cleaning in process	▬ □ ▬ ○	Flashing Green	Off	Flashing Green	Off
<b>Service Notification</b>					
Cleaning required	◁ ▬ ▷ ○	Off	Flashing Yellow	Off	Off
Cleaning tape used up	◁ ▬ ▷ ○	Off	Flashing Green/ Yellow	Off	Off
Recoverable error <sup>b</sup>	▬ ▬ ▷ ○	Yellow	Green	Yellow	Off
Unrecoverable error <sup>b</sup>	▬ □ ▷ ○	Yellow	Off	Yellow	Off
Factory service required <sup>c</sup>	◁ □ ▷ ●	(May be illuminated green, yellow, or off.)			Flashing Red
Broken tape	▬ □ ▬ ○	Flashing Green/ Yellow	Off	Flashing Green/ Yellow	Off
Format recovery <sup>d</sup>	◁ □ ▬ ○	Off	Off	Flashing Green/ Yellow	Off
Tape path over temperature <sup>e</sup>	◁ □ ▷ ●	Off	Off	Off	Orange

**Table 3-1** LED states (continued)

Operation	LED Pattern	LED #1 ◀	LED #2 □	LED #3 ▶	LED #4 ○
<b>Self Tests</b>					
Self-test passed	◀◀▶▶○	Green	Green	Green	Off
Self-test running	◀▶◀▶○	(Fast scrolling green)			Off
Self-test failed <sup>f</sup>	◀◀▶▶○	Yellow	Yellow	Yellow	Off

- <sup>a</sup> For the power-on self-test, the LEDs scroll sequentially right to left then left to right in yellow and green. LED 4 illuminates in red and green. When POST is completed, LED 4 is illuminated in green.
- <sup>b</sup> Retry the operation. If the problem persists, try power cycling the tape drive to clear the error. If you cannot resolve the problem yourself, contact Exabyte Technical Support. To capture a log of a problem, use VXA2Tool, which you may download from [www.exabyte.com](http://www.exabyte.com).
- <sup>c</sup> You may need to return the tape drive for service; contact Exabyte Technical Support. To get a log of the problem, use VXA2Tool, which is included on the Product CD or you can download it free of charge from [www.exabyte.com](http://www.exabyte.com).
- <sup>d</sup> The tape was written without a valid end-of-data mark, which often occurs if you power-down the tape drive while the tape drive was writing. The tape drive will perform a format recovery, which involves reading the data to determine where the end of data is located. This may take as long as 2 to 3 hours.
- <sup>e</sup> Refer to the [Chapter 4](#) for troubleshooting information.
- <sup>f</sup> If a self-test fails, clean the tape drive with a VXAtape cleaning cartridge. If the failure still occurs, try a new tape.

KEY: Flashing LEDs =  On =  Off = 

## USING VXATAPE CARTRIDGES

The tape drive uses data-quality VXAtape data cartridges, in various lengths, available from Exabyte and authorized sources. These cartridges do not require formatting or other media conditioning before use. See [Table 8-1 on page 8-1](#) for the capacities of the VXAtape cartridges. See [page 3-4](#) for storage guidelines.



### Caution

The VXA-2 tape drive only operates with VXAtape data cartridges. Do not attempt to use other types of cartridges, or you may damage the tape drive.

## SETTING THE WRITE-PROTECT SWITCH

Before you insert a cartridge into the tape drive, make sure the write-protect switch on the cartridge is set correctly, as shown in [Figure 3-3](#).

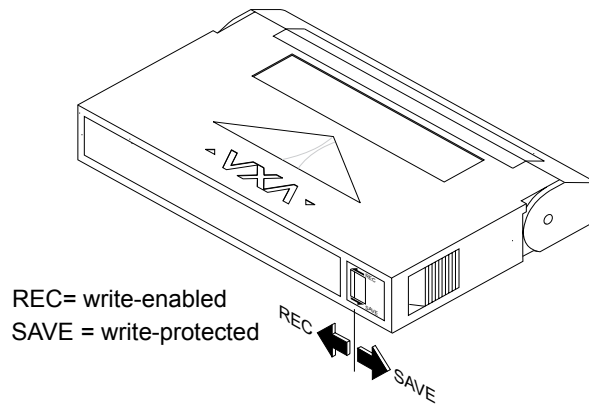

**Figure 3-3** Setting the write-protect switch

## LOADING A CARTRIDGE

Insert the front of the cartridge through the tape drive door into the loader mechanism. (The colored write-protect tab on the cartridge should be closest to the tape drive's eject button.) Gently push the cartridge until the tape drive's loader mechanism activates and completes the tape-loading process.

The tape drive loads the tape in approximately 40 seconds, during which time, LED 2 flashes green. When LED 2 is steady green, the tape drive is ready to begin write and read operations.

## UNLOADING A CARTRIDGE

To unload a cartridge, press the eject button. The tape drive completes any command in process, writes any buffered information to tape, rewinds to the beginning of the tape, and ejects the cartridge in approximately 1 to 2 minutes.

## CARTRIDGE STORAGE GUIDELINES

If VXA tape cartridges are stored properly, you can expect to successfully recover data from them for 30 years. Be aware that the 30-year storage life is for an archival tape, not a tape being used for daily backups.

As a general rule, use a new (or relatively unused) cartridge to store any critical data you may need to recover many years from now. Do not use a cartridge that has reached its retirement point. For routine backups that get overwritten each day or week, it is acceptable to reuse cartridges until they are ready for retirement.

Proper storage of cartridges helps prevent media-related problems. To ensure a storage period of 30 years, follow these guidelines:

- ▶ Remove the cartridge from the tape drive and store it as soon as possible after you have finished writing or reading data. Avoid handling the cartridge excessively. Never open the cartridge door or touch the tape.
- ▶ Label each cartridge.
- ▶ Set the cartridge write-protect switch to prevent accidental over-writing by moving the switch to the edge of the cartridge. (See [page 3-4](#).)
- ▶ Keep each cartridge in its protective case or a container designed for cartridge storage.
- ▶ Store cartridges away from copiers and printers to avoid contamination by toner and paper dust.
- ▶ Store cartridges away from objects or devices that emit strong magnetic fields.

## CLEANING THE TAPE DRIVE

This section describes when and how to clean the tape drive to maintain optimal performance. Circulating air may introduce debris into the tape path. If debris builds up on the heads, error rates increase and backups take longer because the tape drive must rewrite the data. The VXA-2 tape drive includes an internal cleaning wheel to remove contamination from the tape path. However, you should still clean the tape drive regularly with a separate cleaning cartridge to maximize drive reliability and the life of your tapes.

### DETERMINING WHEN TO CLEAN THE TAPE DRIVE

When the tape drive requires cleaning, LED 2 flashes yellow. The tape drive should be cleaned as soon as possible after this LED begins flashing.

**NOTE:** Some software applications may notify you that the tape drive requires cleaning. Refer to your software documentation for more information.

## USING A CLEANING CARTRIDGE

Insert a VXAtape Cleaning Cartridge into the tape drive. The tape drive automatically performs the cleaning cycle in less than one minute. When finished, the tape drive ejects the cleaning cartridge and LED 2 turns off.

**NOTE:** If there are no more cleaning cycles remaining on the cleaning cartridge, the tape drive ejects the cartridge without performing the cleaning and LED 2 flashes green and yellow.



### Caution

Do not use any cleaning method other than the VXAtape Cleaning Cartridge (or a cleaning cartridge approved by Exabyte for use with VXA drives). Using other cleaning methods may void the tape drive's warranty.

Do not rewind and reuse the material in a cleaning cartridge. Reuse may redistribute contaminants previously removed from the tape path. If all cleaning material has been used, discard the cartridge and use a new cleaning cartridge.

---

---

## RESETTING THE TAPE DRIVE

To reset the VXA-2 drive, perform one of the following steps:

- ▶ Press and hold the unload button for at least 10 seconds, then release the button. This clears any error, ejects any cartridge that is in the tape drive (unless a hardware error occurred), and resets the tape drive.

**NOTE:** If the tape drive contains a cartridge, the tape drive rewinds the tape to the beginning before ejecting the cartridge. The time required to complete the rewind depends on what size cartridge you are using and if the tape was positioned near the end.

- ▶ Turn off the tape drive, wait 10 seconds, then turn it on again (avoid this option if the tape drive contains a cartridge).
- ▶ Send a bus device reset (0Ch) message to the tape drive. A device reset clears all input/output (I/O) processes on that SCSI bus.
- ▶ Send a SCSI bus reset. (Make sure no other devices are using the SCSI bus.)

# 4

## TROUBLESHOOTING

This chapter describes problems that you might encounter while operating the VXA-2 tape drive and provides suggestions for resolving the problems.

**NOTE:** The Support section of the Exabyte web site, [www.exabyte.com](http://www.exabyte.com), also provides helpful troubleshooting tips.

### PROBLEMS AND SOLUTIONS

#### TAPE DRIVE WILL NOT ACCEPT A CARTRIDGE

If the tape drive does not accept a cartridge when you insert it into the tape drive door, do the following:

1. Determine if there's already a cartridge loaded.

Press the eject button; there may be a cartridge already loaded in the tape drive.

2. Make sure you are using VXATape cartridges.

If the cartridge you are attempting to load is not a VXATape cartridge, the tape drive automatically ejects it.

3. Check to see if LED 4 is orange, indicating that the tape drive is over-temperature (see "LED 4 is Orange" on page 4-2).

4. Power cycle the tape drive.

Power down the tape drive. Wait 10 seconds, then turn the tape drive back on.

On power-up, observe the tape drive's LED code sequence. If the LEDs do not illuminate, check the power supply and power cable connection. If the tape drive completes the power-on sequence normally, but still does not accept the cartridge, contact Exabyte Technical Support (see page iv).

If power to the tape drive was interrupted when you originally attempted to load a cartridge, the tape drive detects the tape when its power is restored and then rewinds the tape. If this is the case, press the eject button, remove the cartridge, and begin the session again.

## LED 4 IS ORANGE

If LED 4 is orange, the tape drive is over temperature and must cool down before operations can continue. Do the following:

1. Wait for the tape drive to cool.

When the tape drive cools down, LED 4 turns off. Do not attempt to load a cartridge or perform any operations during this time. If there is a tape loaded in the tape drive, press the eject button to unload the tape and move it to a cooler environment.

2. If necessary, power cycle the tape drive.

If the tape drive does not cool down on its own, power down the tape drive. Wait a few minutes, then turn the tape drive back on. If LED 4 is still orange after power-up, the tape drive may be in an environment that is too hot. If the tape drive is an internal model, check that the top and rear ventilation slots are not blocked in the enclosure and that the tape drive is not located near devices that are emitting excessive heat. If the tape drive is an external model, the enclosure's fan may not be working properly and you should return the tape drive for service.

If you cannot determine the cause of the over-temperature condition yourself, contact Exabyte Technical Support (see [page iv](#)).

## TAPE DRIVE WILL NOT EJECT A CARTRIDGE

If the tape drive does not eject a cartridge when you press the eject button, do the following:

1. Use your application software to eject the cartridge.

To protect against accidental tape ejection during a backup or restore operation, many applications prevent using the tape drive's eject button for media removal.

2. If you cannot eject the cartridge through the application, reset the tape drive.

Press and hold the unload button for at least 10 seconds, then release the button. This clears any error, ejects any cartridge that is in the tape drive (unless a hardware error occurred), and resets the tape drive.

**NOTE:** If the tape drive contains a cartridge, the tape drive rewinds the tape to the beginning before ejecting the cartridge. The time required to complete the rewind depends on what size cartridge you are using and if the tape was positioned near the end.

### 3. Power cycle the tape drive.

Power down the tape drive. Wait 10 seconds, then turn the tape drive back on. Depending on what function the drive was performing before the reset, the drive may automatically start a lengthy format recovery process, which involves reading the data to determine where the end of data is located. This may take as long as 2 to 3 hours. Wait for the format recovery to complete.

### 4. If the cartridge appears to be stuck in the tape drive, return the tape drive for service.

If you still cannot eject the cartridge, you may need to return the tape drive for repair with the cartridge in place. The cartridge will be removed and returned to you.

## THE OPERATING SYSTEM OR APPLICATION SOFTWARE DOES NOT “SEE” THE TAPE DRIVE

If the tape drive powers up, loads and unloads cartridges, but is not recognized by the operating system or application software, do the following:

### 1. Verify that the tape drive is supported by your operating system and application software.

To obtain information about which operating systems and software applications are compatible with the VXA-2 tape drive, visit the Support section of Exabyte’s web site, [www.exabyte.com](http://www.exabyte.com).

If necessary, install device drivers for the tape drive during the software installation. Follow the instructions provided with your application software for installing the tape drive device drivers. The CD included with the tape drive provides device drivers for use with several computer operating systems.

### 2. Make sure the tape drive is installed properly on the bus, described in [Chapter 2](#). In particular, check the following:

- ▶ Is the tape drive set to a unique SCSI ID?
- ▶ Is a terminator installed at the physical end of the SCSI bus? Try another terminator.
- ▶ Is there a broken cable or defective connector? Try another SCSI or FireWire cable.
- ▶ Is the cable correctly oriented and firmly seated on the tape drive connector?

3. Reboot your system.

Many SCSI host bus adapters display a list of detected devices during the system boot process. Make sure that your tape drive is listed.

---

**! Important** If you have an external tape drive, make sure that it is powered on before restarting the system.

---

If your tape drive **is not detected** by the host bus adapter, check the following:

- ▶ Is there a broken cable or defective connector? Try another SCSI or FireWire cable.
- ▶ Is the cable connector correctly oriented and firmly seated on the tape drive connector?
- ▶ Try another known good device in the same location on the bus.
- ▶ If there are other devices on the same SCSI or FireWire bus, remove them. Reboot the system and see if your tape drive is detected. Reconnect the other devices to the bus one by one, rebooting the system after each addition.

If your tape drive **is detected** by the host bus adapter, the problem may be with the cable or bus termination. Check the following:

- ▶ Is there a broken cable or defective connector? Try another SCSI or FireWire cable.
- ▶ Is a terminator installed at the physical end of the SCSI bus? Try another SCSI terminator.

4. Contact Exabyte Technical Support.

If you cannot resolve the problem yourself, contact Exabyte Technical Support (see [page iv](#)).

## A SERVICE NOTIFICATION LED CODE APPEARS

If one of the Service Notification LED codes appears (see [Table 3-1 on page 3-2](#)), do the following:

1. Clean the tape drive.

See [page 3-5](#) for cleaning instructions; LED 2 flashes yellow when the tape drive needs to be cleaned. Use only an Exabyte-approved VXAtape Cleaning Cartridge.

**2.** Retry the read or write operation.

If the tape drive was attempting to perform a read or write operation when the error occurred, eject the cartridge, insert it again, and retry the operation. If this does not solve the problem, load a new cartridge and try again.

**3.** Power cycle the tape drive.

If the problem persists, turn the tape drive off. Wait 10 seconds, then turn the tape drive back on.

**4.** Contact Exabyte Technical Support.

If you cannot resolve the problem yourself, contact Exabyte Technical Support (see [page iv](#)).

**BACKUP SOFTWARE IS REPORTING AN ERROR**

If your backup software reports a tape error, one of the following situations may have occurred:

- ▶ The tape drive needs cleaning (see [page 3-5](#)). Always try cleaning the tape drive before you assume the cartridge is bad. Be sure to use a VXAtape Cleaning Cartridge.
- ▶ The cartridge is incompatible with the VXA-2 drive. Be sure to use a VXAtape cartridge.
- ▶ If you are trying to write data, the cartridge may be write-protected. Check the switch on the edge of the cartridge. If the switch does not cover the opening, the tape is write-protected. If the switch covers the opening, you can write to the tape. Use a pen or small screwdriver to move the switch. (See [Figure 3-3](#).)
- ▶ The cartridge is not inserted properly in the tape drive. Remove the cartridge, then reinsert it and retry the operation.
- ▶ The tape drive is not properly installed on the bus, described in [Chapter 2](#). This may result in intermittent errors of various types.

If you cannot resolve the problem yourself, contact Exabyte Technical Support (see [page iv](#)).

## TROUBLESHOOTING WITH VXA2TOOL

To troubleshoot problems with the tape drive, you can use the VXA2Tool diagnostic software. This program allows you to monitor drive performance, conduct diagnostic testing, and update the firmware. VXA2Tool is available from the Support section of Exabyte's web site at [www.exabyte.com](http://www.exabyte.com). The readme file that accompanies the program (or the online help for the Windows version) provides instructions for using VXA2Tool.

# SERVICE AND MAINTENANCE

This chapter provides information about service and maintenance for the tape drive, including:

- ▶ Returning the tape drive for service
- ▶ Upgrading firmware
- ▶ Obtaining a diagnostic listing

## RETURNING THE TAPE DRIVE FOR SERVICE

If you need to return the tape drive to the factory for service, follow these steps:

1. Before returning a drive for service, contact Exabyte Service (see [page iv](#)) or your Exabyte-authorized service provider for return authorization and shipping instructions. If your service provider instructs you to return the tape drive directly to Exabyte, contact Exabyte Service (1-303-417-7791) to obtain a Return Materials Authorization (RMA) number and the shipping address.
2. Remove and keep all cartridges, cables, and terminators.



### Caution

If a cartridge is stuck in the tape drive, do not attempt to manually extract it. You could damage the cartridge or tape drive. If necessary, contact Exabyte Technical Support for assistance.

---

---

3. When repacking and shipping a tape drive, use the original shipping carton and packing materials (or replacement packaging obtained from Exabyte) to avoid damaging the tape drive. The shipping and packaging materials are not intended for shipping items other than VXA-2 drives.



### Caution

Exabyte is not responsible for shipping damage caused by an improperly packaged drive.

To avoid damaging the tape drive and voiding your warranty, use the original shipping materials (or replacement materials from your vendor).

---

---

## UPGRADING FIRMWARE

You can obtain firmware for the VXA-2 tape drive from the Exabyte web site or from Exabyte Technical Support. To upgrade the software, you need to use VXA2Tool, a diagnostic software application that uses the host computer to transfer the firmware over the tape drive's SCSI or FireWire interface. VXA2Tool is available for a variety of operating environments. It can be downloaded for free from Exabyte's web site ([www.exabyte.com](http://www.exabyte.com)).

## OBTAINING A DIAGNOSTIC LISTING

You can obtain a diagnostic listing (dump) from the tape drive using VXA2Tool (described in the previous section). You can download the VXA2Tool program from Exabyte's web site. The readme file that accompanies the program (or the online help for the Windows version) provides instructions for creating a diagnostic listing.

# OVERVIEW OF THE SCSI COMMAND PROTOCOL

This chapter provides an overview of the SCSI command protocol used by the SCSI and FireWire models of the tape drive. It includes the following topics:

- ▶ Communication interface versus command protocol
- ▶ SCSI-2 command protocol

## COMMUNICATION INTERFACE VERSUS COMMAND PROTOCOL

When a device is connected to a host computer, their interaction is accomplished via a *communication interface* (for example, a parallel SCSI bus or FireWire connection). The communication interface is comprised of the physical interface (for example, cables, connectors, and control circuitry) and the signaling protocol used during communication.

The physical interface determines the number of devices that can be attached to a bus or network loop, the maximum length of the cables, and the physical characteristics of the cable itself (for example, the number of wires, shielding, and so forth). The signaling protocol defines the electrical characteristics and timing of signals carried by the cable, the message system requirements, transmission speeds and maximum data transfer rates, as well as the encoding and decoding of the individual bit patterns representing commands passing between the individual devices.

The format and content of the information carried over the communication interface, as well as how each device uses and responds to the information, is governed by a *command protocol*. The command protocol determines how the host (or initiator) interacts with the target device (for example, the tape drive) by issuing commands to control its operation, transferring data, and responding to status information. The target device responds to commands from the host by performing the requested operation (for example, writing or reading data on magnetic tape) and returning status information.

The VXA-2 tape drive is available with either a parallel SCSI bus communication interface or a FireWire communication interface. The differences between the two interfaces arise primarily from how each interface handles device addressing and how each handles transmitting SCSI commands, data, and status between the host and the tape drive. Regardless of the communication interface, the operation of the tape drive is governed by the SCSI command protocol.

The following sections describe how the SCSI command protocol is implemented in the tape drive. Refer to the *VXA-2 Tape Drive SCSI Reference* for detailed information about the SCSI command protocol. [Chapter 7](#) provides information about both the SCSI and FireWire communication interfaces.

## SCSI-2 COMMAND PROTOCOL

This section provides an overview of the SCSI-2 command protocol supported by both the SCSI and FireWire versions of the VXA-2 tape drive.

### COMMAND SET

[Table 6-1](#) lists and briefly describes the SCSI-2 command set supported by the tape drive.

**Table 6-1** SCSI command set

Command	Hex Code	Description
ERASE	19h	Causes the tape drive to erase all data from the current location to the end of partition.
INQUIRY	12h	Requests that information about drive parameters be sent to the initiator.
LOAD/UNLOAD	1Bh	Causes the tape drive to load or unload a cartridge.
LOCATE	2Bh	Positions the tape at a specified logical position or changes partitions. (Typically, this position is determined by data that was obtained through a previous READ POSITION command.)
LOG SELECT	4Ch	Manages a set of internal counters regarding read and write error recovery operations and amounts of data compressed. The initiator can set threshold and cumulative values for the counters or reset the counters.
LOG SENSE	4Dh	Returns the values of the counters managed by the LOG SELECT command.
MODE SELECT	15h	Allows you to specify medium, logical unit, and device parameters.
MODE SENSE	1Ah	Enables the tape drive to report medium, logical unit, or device parameters.

**Table 6-1** SCSI command set (continued)

Command	Hex Code	Description
PREVENT/ALLOW MEDIUM REMOVAL	1Eh	Allows or disallows the removal of the cartridge from the tape drive.
READ	08h	Transfers one or more bytes or blocks of data from the tape to the initiator.
READ BLOCK LIMITS	05h	Requests that the tape drive return data identifying the maximum and minimum logical block lengths supported.
READ BUFFER	3Ch	Creates a diagnostic listing of the tape drive's current state or the contents of the tape drive's data buffer.
READ POSITION	34h	Reports the tape drive's current logical position, but does not cause tape motion to occur. Used in conjunction with the LOCATE command.
RECEIVE DIAGNOSTIC RESULTS	1Ch	Reports the results of the tests requested by a previous SEND DIAGNOSTIC command.
RELEASE UNIT	17h	Releases the tape drive from exclusive use by the initiator that had previously reserved it with a RESERVE UNIT command.
REQUEST SENSE	03h	Requests that the tape drive transfer sense data to the initiator.
RESERVE UNIT	16h	Reserves the tape drive for exclusive use by the initiator that issued the command.
REWIND	01h	Causes the tape drive to rewind the tape to the logical beginning of partition.
SEND DIAGNOSTICS	1Dh	Causes the tape drive to perform certain self-diagnostic tests.
SPACE	11h	Enables the tape drive to perform forward or backward searches using logical blocks, filemarks, or setmarks. Also allows spacing to end of data (EOD).
TEST UNIT READY	00h	Allows you to determine if the tape drive is ready to accept an appropriate medium access command.
VERIFY	13h	Enables the tape drive to verify one or more logical blocks of data on the tape.
WRITE	0Ah	Transfers one or more bytes or blocks of data from the initiator to the tape drive.
WRITE BUFFER	3Bh	Transfers new microcode from the initiator into the tape drive's EEPROM.
WRITE FILEMARKS	10h	Causes the tape drive to write any data remaining in its buffer, then to write one or more filemarks or setmarks to tape.

## STATUS BYTES

After the tape drive executes a command, it issues a status byte to the initiator that indicates whether it performed the command successfully. [Table 6-2](#) describes the four status bytes supported by the tape drive.

**Table 6-2** Status byte descriptions

Status byte	Hex value	Description
Good	00h	Indicates that the tape drive successfully completed the operation.
Check Condition	02h	Indicates that an error, exception, or abnormal condition has caused sense information to be set. The initiator can issue a REQUEST SENSE command to access this information.
Busy	08h	Indicates that the tape drive is busy. This status is sent whenever the tape drive is unable to accept a command from an initiator.
Reservation Conflict	18h	Indicates that the tape drive is reserved for the exclusive use of another initiator.

## SENSE KEYS

When the tape drive returns Check Condition status to the initiator, the initiator can issue a REQUEST SENSE (03h) command to receive information about the error, exception, or abnormal condition. This information includes a sense key, which describes the general error or change of state. [Table 6-3](#) describes the sense keys supported by the tape drive. Refer to the *VXA-2 Tape Drive SCSI Reference* for a detailed explanation of the information returned by the REQUEST SENSE (03h) command.

**Table 6-3** Supported sense keys

Sense key	Hex Value	Description
No Sense	0h	Indicates that there is no specific sense key information to be reported.
Recovered Error	1h	Indicates that the last command completed successfully with some recovery action performed by the tape drive. Details may be available by examining the additional sense bytes and the information field.
Not Ready	2h	Indicates that the tape drive does not contain a data cartridge or that the data cartridge is not loaded. Operator intervention may be required to correct this condition.
Medium Error	3h	Indicates that the command terminated with a non-recoverable error condition that may have been caused by a flaw in the tape or an error in the recorded data. The tape drive may also return this sense key if it is unable to distinguish between a flaw in the tape and a specific hardware failure (sense key 4h).

**Table 6-3** Supported sense keys (continued)

Sense key	Hex Value	Description
Hardware Error	4h	Indicates that the tape drive detected a non-recoverable hardware failure (for example a device failure or parity error) while performing the command or during a self-test.
Illegal Request	5h	Indicates that there was an illegal parameter in the CDB or in the additional parameters supplied as data for a command or that the tape drive is in the wrong mode to execute the command. If the tape drive detects an invalid parameter in the CDB, the tape is not written. If the tape drive detects an invalid parameter in the additional parameters supplied as data, the tape may already be altered. This sense key can also indicate an invalid Identify message.
Unit Attention	6h	Indicates one of the following: <ul style="list-style-type: none"> <li>▪ The tape drive has been reset (by a power-on reset, a Bus Device Reset message, or a SCSI bus reset).</li> <li>▪ An initiator changed the MODE SELECT parameters since the last command was issued to the tape drive.</li> <li>▪ The eject button was pressed and the data cartridge was ejected.</li> <li>▪ A data cartridge was inserted and automatically loaded.</li> <li>▪ The internal microcode (firmware) was changed.</li> <li>▪ A log parameter (counter) reached a specified threshold value (assuming that RLEC bit on the MODE SELECT Control Mode page is set to 1).</li> </ul> This sense key is reported the first time any command is issued by each initiator after the condition is detected, and the requested command is not performed. This sense key is cleared when the next command other than INQUIRY or REQUEST SENSE is received by the tape drive.
Data Protect	7h	Indicates that a command that writes to tape was attempted on a write-protected data cartridge. The write operation is not performed.
Blank Check	8h	Indicates that the tape drive encountered blank tape or format-defined EOD (blank tape) during a read, space, or locate operation.
Aborted Command	Bh	Indicates that the tape drive aborted the command. This condition occurs when an Initiator Detected Error (05h) message is received during command execution or when a Message Reject (07h) or SCSI bus parity error is detected by the tape drive during Command or Data Out phase. The initiator may be able to recover by trying the command again.
Volume Overflow	Dh	Indicates that the last WRITE or WRITE FILEMARKS command reached the physical end of tape (PEOT) and that data may remain in the buffer.
Miscompare	Eh	Indicates that the source data did not match the data read from the tape.

## SCSI MESSAGES

The SCSI message system allows communication between a SCSI initiator and tape drive for interface management. A message can be one byte or multiple bytes. [Table 6-4](#) lists the SCSI messages that the tape drive supports.

**Table 6-4** SCSI messages

Message	Hex Code	Direction
Command Complete	00h	To initiator
Extended Messages	01h (Synchronous)	To initiator/to drive
	03h (Wide)	To initiator/to drive
Save Data Pointers	02h	To initiator
Restore Data Pointers	03h	To initiator
Disconnect	04h	To initiator
Initiator Detected Error	05h	To tape drive
Abort Task Set	06h	To tape drive
Message Reject	07h	To initiator/to drive
No Operation	08h	To tape drive
Command Complete	00h	To initiator
Message Parity Error	09h	To tape drive
Bus Device Reset	0Ch	To tape drive
Identify	80h-FFh	To initiator/to drive

# OVERVIEW OF THE COMMUNICATION INTERFACE

This chapter provides an overview of the communication interfaces available for the VXA-2 tape drive. The tape drive is available with the following communication interfaces:

- ▶ LVD SCSI
- ▶ FireWire

See [Chapter 6](#) for information about the SCSI command protocol used by the tape drive.

## SCSI INTERFACE REQUIREMENTS

The VXA-2 tape drive is available with a wide, Ultra2 low-voltage differential (LVD) SCSI interface. This section provides general information about the specifications for the tape drive's Small Computer System Interface (SCSI), including:

- ▶ SCSI cable requirements
- ▶ SCSI connector requirements
- ▶ Terminator requirements

**! Important**

To avoid SCSI bus hangs, do not connect the tape drive to an HVD SCSI bus.

Although you can attach an LVD SCSI tape drive to a single-ended SCSI bus, doing so is not recommended for the following reasons:

- ▶ The tape drive will be forced to operate as a single-ended device. The maximum burst data transfer rate on a wide, single-ended SCSI bus is 40 MB/second, which is only half the maximum provided by an LVD SCSI bus.
- ▶ If the bus is shared by multiple devices, using a single-ended bus may negatively impact the tape drive's performance.
- ▶ The maximum cable lengths for a single-ended bus are shorter than those for an LVD bus. Exceeding the maximum cable length can result in an unstable bus.
- ▶ Although the LVD SCSI interface is compatible with narrow single-ended SCSI buses, Exabyte does not support using the tape drive in a narrow single-ended SCSI environment.

**INTERNAL MODEL**

This section describes the cable, connector, and terminator requirements for the internal LVD SCSI tape drive.

**SCSI Cable Requirements**

The cable connected to the tape drive SCSI connector must meet the LVD specifications listed in [Table 7-1](#).



**Caution**

Using a noncompliant SCSI cable will degrade VXA-2 performance and can cause random, nonreproducible errors. Exabyte recommends using shielded cables.

**Table 7-1** SCSI cable and connector specifications

Specification	Requirement
General	Wide, LVD SCSI-3
Connector	68-pin male
Maximum length	12 meters (39.2 feet)
Stub length	<ul style="list-style-type: none"> <li>▪ No greater than 0.1 meters should be used off the mainline connection within any connected equipment.</li> <li>▪ The stub length within the tape drive is less than 2.5 centimeters (1 inch).</li> </ul>
Impedance	Between 90 and 140 ohms. An impedance of greater than 100 ohms is recommended. To minimize discontinuities and signal reflections, all cables on the bus should have the same impedance.
Conductor size	28 AWG (0.08097 mm <sup>2</sup> ) A minimum of 28 AWG will minimize noise effects and ensure proper distribution of terminator power.

## SCSI Connector Requirements

Table 7-2 lists the pin assignments for the tape drive's SCSI connector.

**Table 7-2** Pin assignments for the wide LVD connector

Pin #	Signal	Pin #	Signal
1	+DB (12)	35	-DB (12)
2	+DB(13)	36	-DB(13)
3	+DB(14)	37	-DB(14)
4	+DB(15)	38	-DB(15)
5	+DB(P1)	39	-DB(P1)
6	+DB(0)	40	-DB(0)
7	+DB(1)	41	-DB(1)
8	+DB(2)	42	-DB(2)
9	+DB(3)	43	-DB(3)
10	+DB(4)	44	-DB(4)
11	+DB(5)	45	-DB(5)
12	+DB(6)	46	-DB(6)
13	+DB(7)	47	-DB(7)
14	+DB(P)	48	-DB(P)
15	GROUND	49	GROUND
16	DIFFSENS	50	GROUND
17	TERMPWR	51	TERMPWR
18	TERMPWR	52	TERMPWR
19	OPEN	53	OPEN
20	GROUND	54	GROUND
21	+ATN	55	-ATN
22	GROUND	56	GROUND
23	+BSY	57	-BSY
24	+ACK	58	-ACK
25	+RST	59	-RST
26	+MSG	60	-MSG
27	+SEL	61	-SEL
28	+C/D	62	-C/D
29	+REQ	63	-REQ
30	+I/O	64	-I/O
31	+DB(8)	65	-DB(8)
32	+DB(9)	66	-DB(9)
33	+DB(10)	67	-DB(10)
34	+DB(11)	68	-DB(11)

## SCSI Terminator Requirements

If the internal tape drive is the last device on the SCSI bus, you must terminate the bus by installing a pass-through terminator on the tape drive's SCSI connector. Or, if there is an unused connector at the end of the SCSI cable, you can terminate the bus there.

**Note:** If you will be installing the tape drive in an enclosure and using an external terminator, you must install an AMP 796051-1 (SE/LVD Multi-mode), or an equivalent LVD terminator.

## EXTERNAL DRIVE

This section describes the cable, connector, and terminator requirements for the external LVD SCSI tape drive.

### SCSI Cable Requirements

For the external tape drive, select a cable that complies with the SCSI-3 specification and meets the requirements listed in [Table 7-3](#).

**Table 7-3** SCSI cable specifications for the external model

Specification	Requirement
Connector type	68-pin male, high-density, shielded, AMP 750752-1 or equivalent
Maximum length	12 meters (39 feet) <sup>a</sup>

<sup>a</sup> If only two devices are attached to the bus in a point-to-point configuration, the maximum allowable cable length is 25 meters (82 feet).

### SCSI Terminator Requirements

If the external tape drive is the last device on the SCSI bus, you must terminate the bus by installing an AMP 796051-1 (SE/LVD Multi-mode), or an equivalent LVD terminator, on one of the tape drive's SCSI connectors.

## FIREWIRE INTERFACE CABLE AND CONNECTOR SPECIFICATIONS

The FireWire tape drive, available only as an external model, uses a standard FireWire communication interface. Select a cable that complies with the IEEE 1394a-1995 FireWire specification and meets the requirements listed in [Table 7-4](#).

**Table 7-4** FireWire cable specifications

Specification	Requirement
Connector type <sup>a</sup>	6-pin male, shielded (MOLEX 1394)
Maximum length	4.5 meters (14.8 feet)

<sup>a</sup> To connect the tape drive to an iLink port, use a 6-pin to 4-pin adaptor.

# 8

## SPECIFICATIONS

This chapter provides specifications for the VXA-2 tape drive. This chapter provides the following specifications for the internal and tabletop models of the tape drive:

- ▶ Data capacities
- ▶ Performance specifications
- ▶ Reliability specifications
- ▶ Size and weight
- ▶ Power specifications
- ▶ Environmental specifications
- ▶ Shipping specifications
- ▶ Safety and regulatory agency compliance

### DATA CAPACITIES

Table 8-1 lists the data capacities for the VXA-2 cartridge models.

**Table 8-1** Data capacities in gigabytes (GB)

Cartridge Model	Tape Length	Capacity, <sup>a</sup> Native	Capacity, <sup>a</sup> Compressed <sup>b</sup>
V23	230 meters	80 GB <sup>c</sup>	160 GB
V17	170 meters	59 GB	118 GB
V10	120 meters	40 GB	80 GB
V6	62 meters	20 GB	40 GB

<sup>a</sup> Maximum capacity; assumes the host computer keeps the tape drive streaming.

<sup>b</sup> Assumes a 2:1 compression ratio. Actual compressed capacity varies depending on the type of data being recorded. The VXA-2 tape drive uses the ALDC (Adaptive Lossless Data Compression) algorithm and integrated circuit chip. The ALDC algorithm is compliant with the European Computer Manufacturers Association (ECMA) standard. Data compression is controlled by the software application.

<sup>c</sup> One gigabyte equals 1,000,000,000 bytes.

## PERFORMANCE SPECIFICATIONS

This section describes the performance specifications for the tape drive. The tape drives are factory tested to these specifications using VXAtape media.

### DATA TRANSFER RATES

Table 8-2 lists the maximum data transfer rates that the tape drive can achieve.

**Table 8-2** Maximum data transfer rates

<b>Data transfer rate</b>	Host matching up to 6.0 megabytes (MB <sup>a</sup> ) per second (12.0 MB/second, compressed)
<b>Burst transfer rate (maximum)</b>	80 MB/second synchronous (SCSI Ultra2 LVD)

<sup>a</sup> One megabyte equals 1,000,000 bytes.

### READ AND WRITE SPECIFICATIONS

Table 8-3 provides read and write specifications for the VXA-2 tape drive.

**Table 8-3** Read and write specifications

<b>Backward compatibility with VXA-1 drives<sup>a</sup></b>	<ul style="list-style-type: none"> <li>▪ Reads tapes written by a VXA-1 tape drive.</li> <li>▪ Writes VXA-1 formatted tapes, so that the VXA-1 drive can read the data.</li> </ul>
<b>Compression</b>	ALDC (Adaptive Lossless Data Compression)
<b>Bit error rate</b>	Less than $1 \times 10^{-17}$
<b>Partitions</b>	2
<b>Buffer</b>	2 megabytes (MB)
<b>Error detection and correction</b>	4 layer Reed Solomon
<b>Format</b>	Discrete Packet Format
<b>Heads (4)</b>	<ul style="list-style-type: none"> <li>▪ 2 write/read heads</li> <li>▪ 2 write check/read heads</li> </ul>
<b>Data media</b>	<ul style="list-style-type: none"> <li>▪ VXAtape cartridges with Advanced Metal Evaporated (AME) media. The tape drive ejects other types of media.</li> <li>▪ No formatting or conditioning required prior to use.</li> <li>▪ 30-year archival life.</li> </ul>

<sup>a</sup> The VXA-2 drive can read or write VXA-1 formatted tapes. However, the VXA-1 tape drive cannot read and write VXA-2 formatted tapes, nor can it use the V23 cartridge.

## TAPE SPEED AND ACCESS TIME

The time required to move the tape to a specified position depends on the operation being performed. [Table 8-4](#) lists the tape speeds and access times for the VXA-2 tape drive.

**Table 8-4** Tape speed and access times

<b>Search speed (maximum)</b>	165 x read/write speed (1 GB/second, native)
<b>Mid-tape reposition time (average)<sup>a</sup></b>	V6 cartridge 75 seconds V10 cartridge: 100 seconds V17 cartridge: 115 seconds V23 cartridge: 150 seconds
<b>Load time (logical)</b>	20 seconds for an initialized tape 30 seconds for an uninitialized tape
<b>Unload time (logical)</b>	50 seconds
<b>Tape speed</b>	18.24 mm/second (typical)

<sup>a</sup> In addition to maximum search speed, the mid-tape reposition times depend on acceleration, deceleration, and read positioning to location.

## RELIABILITY SPECIFICATIONS

[Table 8-5](#) provides reliability specifications for the VXA-2 tape drive.

**Table 8-5** Reliability specifications

<b>Mean Time Between Failures (MTBF)</b>	300,000 hours; 12% duty cycle
<b>Mean Time to Repair (MTTR)</b>	30 minutes
<b>Service life</b>	5 years
<b>Write reliability</b>	Bit error rate of less than $1 \times 10^{-16}$
<b>Read reliability</b>	Bit error rate of less than $1 \times 10^{-17}$
<b>Loads/unloads</b>	50,000 cycles

## SIZE AND WEIGHT

Table 8-6 shows the dimensions and weight for the internal and external tape drives. The internal tape drive is a 5.25-inch form factor drive for integration into an enclosure. The external tape drive is a standalone unit that can fit on a desktop.

**Table 8-6** Size and weight

Specification	Internal Drive	External Drive
Depth	41.2 mm (1.62 in)	86.0 mm (3.38 in)
Depth (with bezel)	42.6 mm (1.68 in)	
Length	203.0 mm (8.0 in)	285.0 mm (11.25 in)
Width	146.0 mm (5.75 in)	227.0 mm (8.93 in)
Width (with bezel)	149.2 mm (5.87 in)	
Weight	1.0 kg (2.2 lbs)	3.0 kg (6.6 lbs)

Figure 8-1 shows the dimensions of the internal drive. Figure 8-2 shows the dimensions of the external drive.

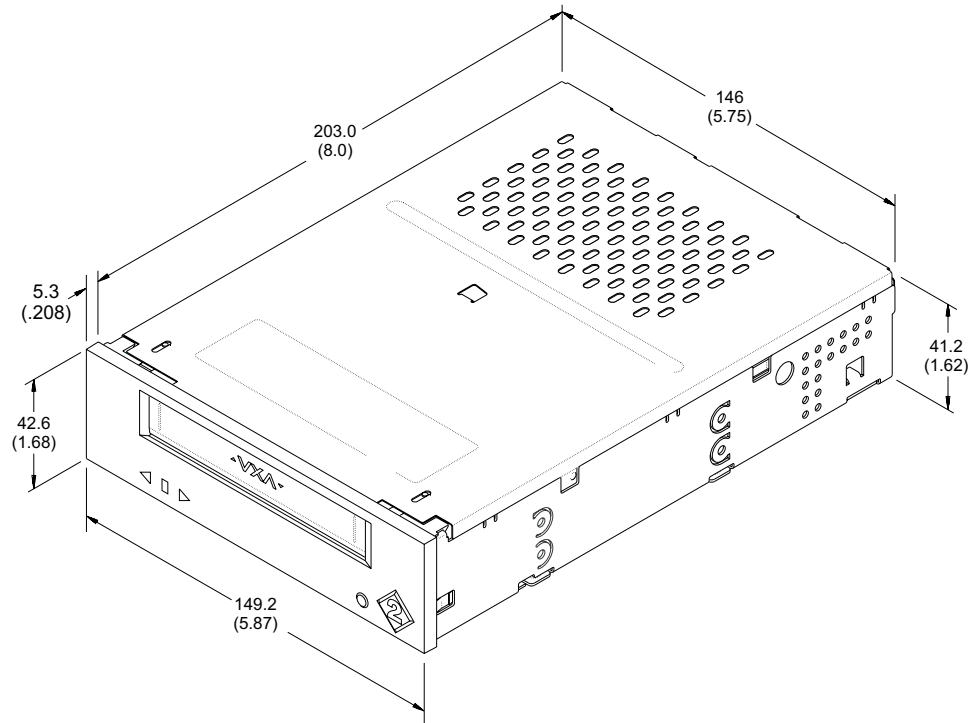

**Figure 8-1** Physical dimensions of the internal model in millimeters (and inches)

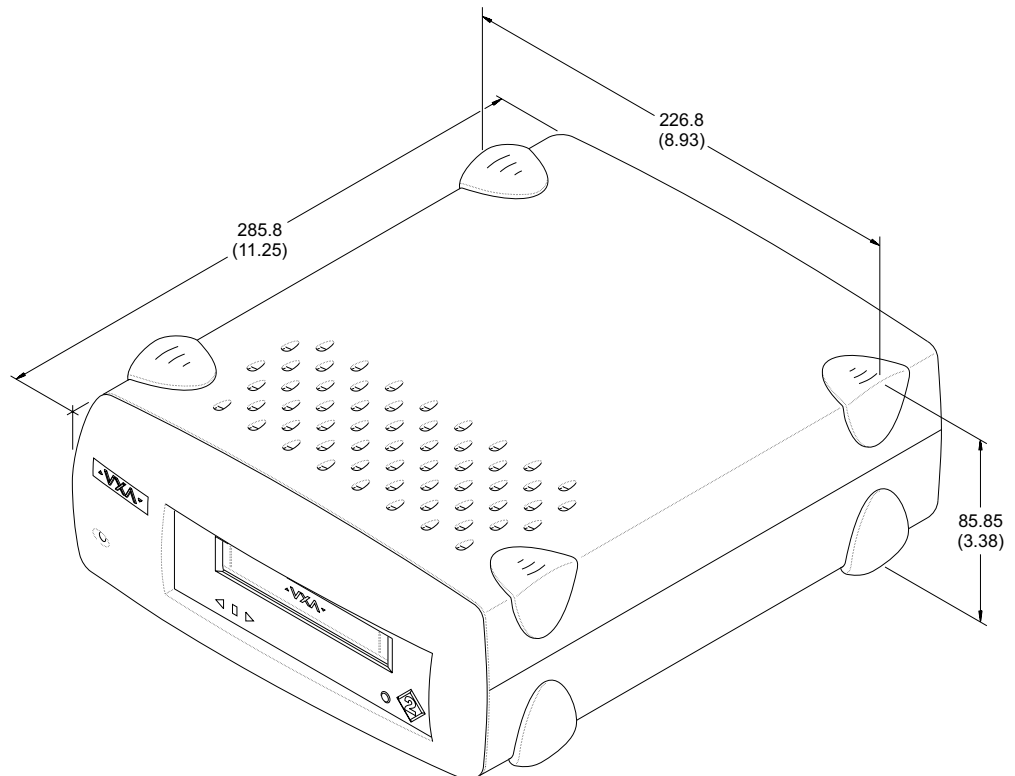

**Figure 8-2** Physical dimensions of the external model in millimeters (and inches)

## POWER SPECIFICATIONS

This section lists the power specifications for the VXA-2 tape drive.

### INTERNAL DRIVE

The power specifications listed in this section are in addition to any requirements for the enclosure in which it is installed.

### Power Connector Pin Assignments

The VXA-2 power connector is compatible with power cables used for standard 5.25-inch half-high devices. The enclosure's power cable connector must be an AMP 1-480424-0 series, or equivalent. [Table 8-7](#) provides pin assignments for the tape drive's power connector.

**Table 8-7** Pin assignments for the power connector

Pin	Assignment
1	+12 VDC
2	Ground, 12 VDC return
3	Ground, 5 VDC return
4	+5 VDC

### DC Voltages

The internal tape drive operates from standard +5 and +12 VDC supply voltages (all specified voltages are DC, no external AC power is used). Table 8-8 defines the power specifications.

**Table 8-8** Power specifications (internal model)

Power	+5 Volts		+12 Volts	
Required supply tolerance:				
Ripple and noise: (50 Hz to 20 MHz) <sup>a</sup>	±5% 125 mVpp max.		±10% 125 mVpp max.	
Operating current (amps):				
Read or write:	1.0 (average)	1.03 (peak)	0.37 (average)	0.37 (peak)
Search/high speed:	0.94 (average)	1.08 (peak)	0.46 (average)	2.08 <sup>b</sup> (peak)
Load/unload:	0.90 (average)	1.10 <sup>c</sup> (peak)	0.39 (average)	2.10 <sup>d</sup> (peak)
Power up:	0.80 (average)	1.25 <sup>e</sup> (peak)	0.10 (average)	0.52 <sup>f</sup> (peak)
Idle:	0.88 (average)	–	0.06 (average)	–

<sup>a</sup> The ripple voltage is included in the total voltage tolerance.

<sup>b</sup> 1.8 seconds maximum.

<sup>c</sup> 0.15 seconds maximum.

<sup>d</sup> 1.4 seconds maximum.

<sup>e</sup> 0.6 seconds maximum.

<sup>f</sup> 1.1 seconds maximum.

**NOTE:** The VXA-2 tape drive does not provide overvoltage or overcurrent protection, except for TERMPWR, which has a resettable fuse. Safety agency certification per IEC-950 requires that the supplied voltages be from a Safety Extra-Low Voltage source.

## Power Consumption

**Table 8-9** shows the internal drive's power consumption when operating and when idle.

**Table 8-9** Power consumption (internal model)

Power Consumption	Power (average)
Read or write:	9.5 watts
Search/high speed:	10.3 watts
Load/unload:	9.2 watts
Power up:	5.2 watts
Idle:	5.2 watts

## EXTERNAL DRIVE

The power specifications for the external tape drive include both the requirements for the tape drive and the enclosure components.

### Power Supply

The external tape drive uses an internal switching power supply. You do not need to change any input settings. The power supply automatically adjusts for changes in voltages and frequency within the specified range. **Table 8-10** lists the general specifications for the power supply.

**Table 8-10** Power supply specifications (external model)

Type	40 watts, switching
Efficiency	70% minimum
Input voltage <sup>a</sup>	90 – 276 VAC
Frequency	47 – 63 Hz

<sup>a</sup> Autoswitching input selection; no user selection required.

## Power Consumption

**Table 8-11** provides power consumption specifications.

**Table 8-11** AC power consumption (external model)

AC input current	1 amp @ 115 VAC 0.6 amp @ 230 VAC
AC inrush current	25 amps @ 115 VAC 50 amps @ 230 VAC

## ENVIRONMENTAL SPECIFICATIONS

This section lists the environmental specifications for the tape drive and the cartridges.

### ENVIRONMENTAL CONDITIONS FOR THE TAPE DRIVE

**Table 8-12** summarizes the environmental requirements for the tape path in either the internal or external models of the tape drive. The following sections provide additional detail about these requirements.

**Table 8-12** Temperature and humidity specifications for the tape drive

Specification	Operating <sup>a,b</sup>	Storage <sup>c</sup> / Nonoperating	Transporting <sup>c</sup>
Temperature range	+5°C to +45°C (+41°F to +113°F)	-40°C to +60°C (-40°F to +140°F)	
Temperature variation	1°C per min; max 10°C per hour (2°F per min; max 18°F per hour)	1°C per min; max 20°C per hour (2°F per min; max 36°F per hour)	
Relative Humidity	20% to 80% non-condensing	5% to 95% non-condensing	
Wet bulb	29°C (84.2°F) max.		
Altitude	-304.8 to +3,048 m (-1,000 to +10,000 ft)		-304.8 to +12,192 m (-1,000 to +40,000 ft)

<sup>a</sup> The tape drive temperature and humidity must be stabilized in the specified environment for at least 24 hours.

<sup>b</sup> Temperature measurements are made in the tape path.

<sup>c</sup> The tape drive is in its original shipping container. When the tape drive is moved from a cooler storage environment to a warmer operating environment, it must acclimate in its packaging for 24 hours to prevent damage from condensation.

### Internal Tape Drive: Operating Temperature and Humidity

**Figure 8-3** provides the temperature and humidity requirements for the internal tape drive, as measured at the tape path. The area within the dotted line represents the operating environment. **Table 8-13** defines the points in the chart.



#### Caution

The operating temperature and humidity specifications are for the tape path. When the tape drive is in an enclosure, the ambient temperature typically must be lower than the maximum temperature to avoid exceeding the maximum at the tape path.

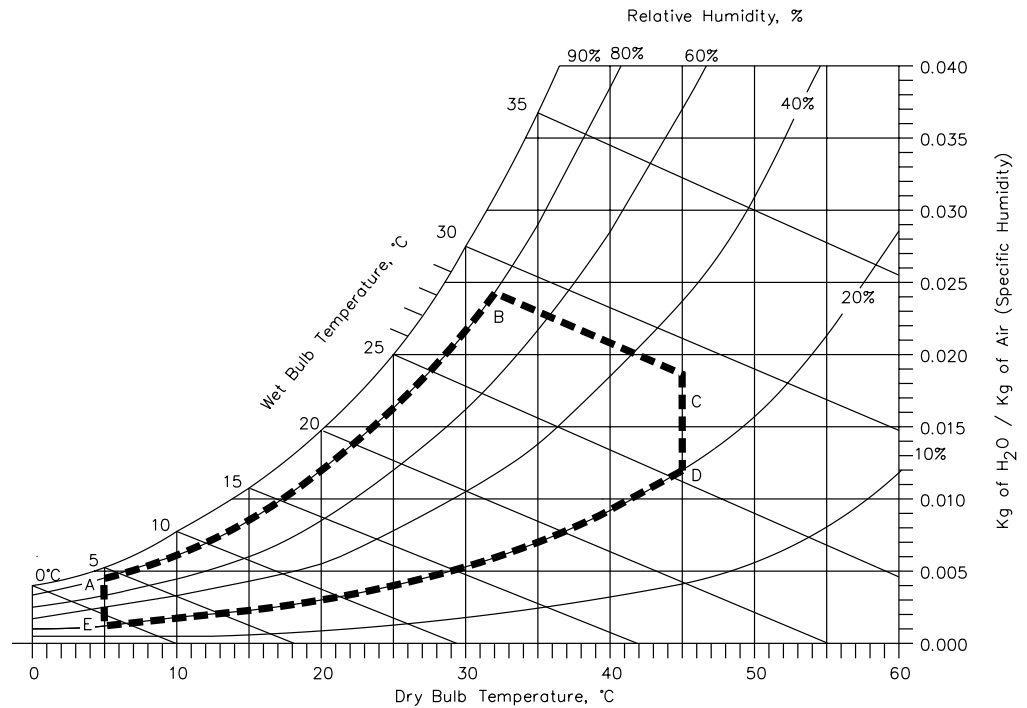

**Figure 8-3** Internal drive: Operating tape path temperature and humidity ranges

**Table 8-13** Internal drive: Operating temperature and humidity points

Point	Temperatures	Humidity
A	5°C	80%
B	32°C	80%
C	45°C	32%
D	45°C	20%
E	5°C	20%

**External Tape Drive: Operating Temperature and Humidity**

Figure 8-4 provides the ambient temperature and humidity requirements for the external tape drive. The area within the dotted line represents the operating environment. Table 8-14 defines the points on the chart. Operation of the external tape drive within these requirements will maintain the proper tape path temperature of the tape drive.

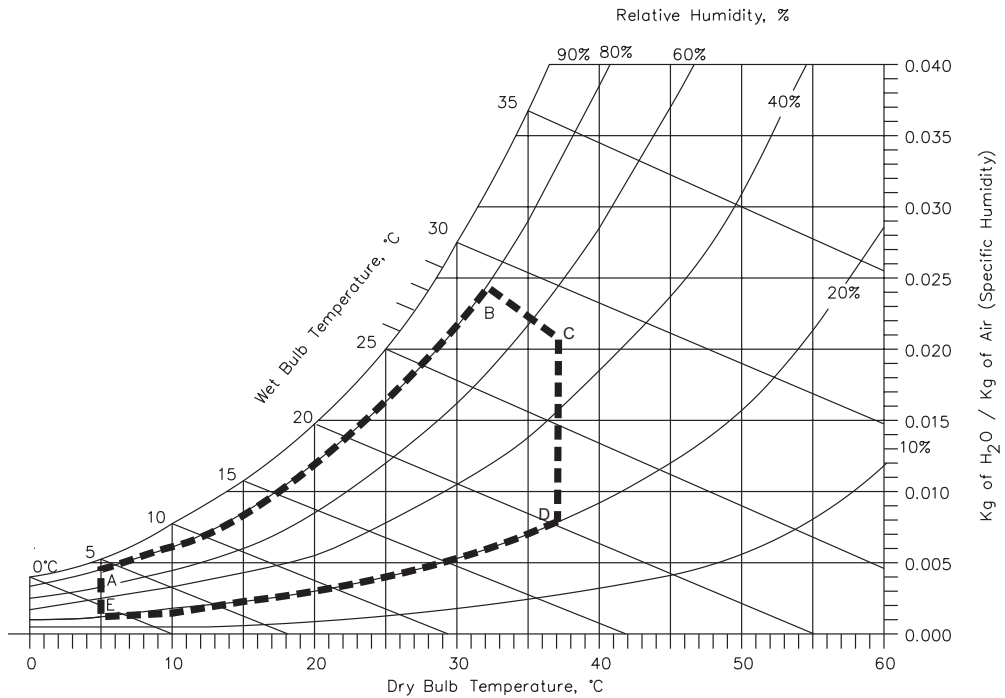

**Figure 8-4** External drive: Operating tape path temperature and humidity ranges

**Table 8-14** External drive: Operating temperature and humidity points

Point	Temperatures	Humidity
A	5° C	80%
B	32° C	80%
C	37° C	57%
D	37° C	20%
E	5° C	20%

### Air Flow Requirements

When mounted in the host enclosure, the tape drive must have adequate air flow. The air flow around the tape drive must be sufficient to prevent tape path temperatures from exceeding 45°C (113°F). The tape drive is equipped with a temperature sensor, located on the system card, that continuously monitors temperature data stored within the tape drive. You can access temperature data through the LOG SENSE command (see the *VXA-2 SCSI Reference*).

## Particulate Contamination Limits

The VXA-2 tape drive is designed to operate in environments that do not exceed the limits listed in [Table 8-15](#).

**Table 8-15** Particulate contamination limits

Particle Size (Microns)	Number of Particles $\geq$ Particle Size per Cubic Meter	Number of Particles $\geq$ Particle Size per Cubic Foot
0.1	$8.8 \times 10^7$	$2.5 \times 10^6$
0.5	$3.5 \times 10^7$	$1.0 \times 10^6$
5.0	$2.5 \times 10^7$	$7.0 \times 10^6$

## Acoustic Noise

[Table 8-16](#) shows the acoustic noise levels of the internal tape drive.

**Table 8-16** Acoustic noise specifications (internal drive)

Operating Mode	$L_{pA}^a$
Powered on, idle, read, or write	40 $L_{pA}$
High-speed search or rewind (up to 2-minute duration)	42 $L_{pA}$

<sup>a</sup> The average A-weighted sound pressure level over the frequency range 5 Hz – 12.5 kHz.

[Table 8-17](#) shows the acoustic noise levels for the external tape drive. When measured in the external enclosure, these levels do not exceed the upper limits specified in the table.

**Table 8-17** Acoustic noise specifications (external drive)

Operating Mode	$L_{pA}^a$
Powered on, idle, read, or write	43 $L_{pA}$
High-speed search or rewind (up to 2-minute duration)	45 $L_{pA}$

<sup>a</sup> The 30-second sustained average A-weighted sound pressure level over the following frequency range: 5 Hz to 12.5 KHz.

## Shock Specifications

The storage and nonoperating shock levels indicate how much shock the tape drive can withstand when it is not operating. The operating shock levels indicate how much shock the tape drive can withstand while reading and writing data. After withstanding this amount of shock, the tape drive operates normally.

Table 8-18 lists the shock specifications for the tape drive.

Table 8-18 Shock specifications

Operating	Nonoperating <sup>a, b</sup>	Transportation <sup>c</sup>
5 g for 3 msec <sup>d</sup> 6 g for 11msec <sup>e</sup>	60 g for 3 msec 50 g for 11 msec	ISTA Procedure 2A

- <sup>a</sup> The tape drive has been unpacked, but no power is applied.
- <sup>b</sup> Half-sine shock pulses are applied to each of the three orthogonal axes. (Three shocks at 60 g at a rate not exceeding 1 shock per second. One shock at 50 g.)
- <sup>c</sup> The tape drive is in its original shipping container.
- <sup>d</sup> Half-sine, at a rate not exceeding 1 shock per second; 20 shocks applied to each of the three orthogonal axes.
- <sup>e</sup> Half-sine, at a rate not exceeding 1 shock per every 3 seconds; 10 shocks applied to each of the three orthogonal axes.

### Vibration Specifications

Table 8-19 lists the operating specifications that indicate the amount of vibration the tape drive can withstand while reading and writing data.

Table 8-19 Vibration specifications

Random vibration <sup>a</sup> applied during operation (reading and writing)	
10 Hz	PSD = 0.0011480 g <sup>2</sup> /Hz
500 Hz	PSD = 0.0011480 g <sup>2</sup> /Hz
Random vibration <sup>b</sup> applied during non-operation (unpacked) and storage (in original packaging)	
1 Hz	PSD = 0.0003 g <sup>2</sup> /Hz
3 Hz	PSD = 0.00055 g <sup>2</sup> /Hz
12 to 100 Hz	PSD = 0.01 g <sup>2</sup> /Hz
400 Hz	PSD = 0.000003 g <sup>2</sup> /Hz
Vibration applied during shipping (in original packaging)	
ISTA Procedure 2A	
Swept sine applied during non-operation <sup>c</sup> and operating <sup>d</sup>	
5 to 500 to 5 Hz <sup>c</sup> 10 to 500 Hz <sup>d</sup>	

- <sup>a</sup> A 0.75 Grms random vibration spectrum is applied to each of three orthogonal axes for a minimum of 30 minutes per axis.
- <sup>b</sup> A 1.06 Grms random vibration spectrum is applied to each of three orthogonal axes for a minimum of 20 minutes per axis.
- <sup>c</sup> Three sweeps at one octave per minute are applied to each axis at 0.75 g (peak) input.
- <sup>d</sup> One sweep at one-quarter octave per minute are applied to each axis at 0.5 g (peak) input.

## ENVIRONMENTAL CONDITIONS FOR THE VXATAPE CARTRIDGES

**Table 8-20** summarizes the environmental requirements for the VXAtape cartridges. You should maintain the temperature and humidity at a steady level within these ranges, and also limit fluctuations in temperature and humidity.

**NOTE:** When a VXAtape is brought into the room where the VXA drive is located, allow the VXAtape to adjust to room temperature and humidity before using it.

**Table 8-20** Temperature and humidity specifications for the VXAtape cartridges

Specification	Operating <sup>a,b</sup>	Storage <sup>a</sup> / Nonoperating	Transporting <sup>c</sup>
Temperature range	+5°C to +45°C (+41°F to +113°F)	+5°C to +32°C (+41°F to +90°F)	−40°C to +45°C (−40°F to +113°F)
Temperature variation	1°C per min; max. 10°C per hour (2°F per min; max. 18°F per hour)	1°C per min; max. 20°C per hour (2°F per min; max. 36°F per hour)	
Relative humidity	20% to 80% noncondensing	20% to 60% non-condensing	5% to 80% non-condensing
Wet bulb	26°C (79°F) max.		
Altitude	−304.8 to +3,048 m (−1,000 to +10,000 ft)		−304.8 to 12,192 m (−1,000 to 40,000 ft)

<sup>a</sup> The cartridge temperature and humidity must be stabilized in the specified environment for at least 24 hours.

<sup>b</sup> Temperature measurements are made in the tape path.

<sup>c</sup> The cartridge is in its original packaging. When the cartridge is moved from a cooler storage environment to a warmer operating environment, it must acclimate in its packaging for 24 hours to prevent damage from condensation.

## PACKAGING AND SHIPPING SPECIFICATIONS

This section describes the packaging and shipping requirements for the tape drive.

### SHIPPING CARTONS

The tape drive is sealed in a static protection bag and shipped in a single-pack or multi-pack carton. [Table 8-21](#) lists the weights and dimensions of the shipping cartons.

**Table 8-21** Shipping carton weights and dimensions

Carton	Weight	Dimensions
<b>Single Pack</b>		
Internal Drive	3 lbs, 4 oz (1.5 kg)	Length: 13.5 in. (34.3 cm) Width: 10.75 in. (27.3 cm) Depth: 8.5 in. (21.6 cm)
External Drive	12 lbs (5.4 kg)	Length: 21 in. (53.3 cm) Width: 15 in. (38.1 cm) Depth: 6.5 in. (16.5 cm)
<b>Multipack: 10 Internal Drives</b>		
10 Drives	25.5 lbs (11.6 kg)	Length: 21.5 in. (54.6 cm) Width: 16 in. (40.6 cm) Depth: 14.5 in. (36.8 cm)

The shipping cartons and internal packing materials are designed so that the enclosed tape drive does not receive a damaging shock when the carton is dropped on any surface, corner, or edge from a height of:

- ▶ Single-pack: 48 in. (121.9 cm), at a velocity change of 192 in./sec (488 cm/sec)
- ▶ Multipack: 36 in. (91.4 cm), at a velocity change of 167 in./sec (424 cm/sec)

### PACKAGING MATERIALS

The tape drive's packing materials are unbleached, reusable, recyclable, and environmentally safe. The materials contain no chlorofluorocarbons (CFCs) or heavy metals. The shipping cartons pass the tests described in the International Safe Transit Association (ISTA) Procedure 2A.

## SAFETY AND REGULATORY COMPLIANCE

The VXA-2 tape drive complies with the regulatory agency standards listed below when installed in accordance with this manual.

The system integrator is responsible for the certification and verification of the final product into which the VXA-2 tape drive is integrated, with the relevant product safety, and EMI and EMC standards.

### UNDERWRITERS LABORATORY



The internal configuration has been evaluated by UL for use in listed finished products. Construction or performance of these components may not warrant listing of the devices on their own. Recognized components may be used in listed products, provided that they are applied within the conditions of acceptability stated in the report.



The external configuration of the VXA-2 tape drive is listed by Underwriters Laboratories, Inc. Representative samples of this product have been evaluated by UL and meet the applicable U.S. and Canadian safety standards.

### TUV PRODUCT SERVICE



Signifies that the VXA-2 internal drive has been tested in accordance with EN60950:2000 and has met the applicable product safety requirements.



The TÜV Mark for the VXA-2 external drive demonstrates that it has met the requirements of EN60950/A11:1997.

## UNITED STATES: FCC DECLARATION OF CONFORMITY



We declare under our sole responsibility that:

Product Name: VXA-2 Tape Drive  
Model Numbers: VXA-2 (internal); VXA-2e (external)  
Product Options: All

To which this declaration relates, is in conformity with the following standard(s) or other normative documents:

ANSI C63.4-1992 Methods of Measurement  
Federal Communications Commission 47 CFR Part 15, Subpart B  
15.107 (a) Class B Conducted Limits  
15.109 (a) Class B Radiated emission Limits

This device complies with Part 15 of the FCC Rules. Operation is subject to the following two conditions: (1) this device may not cause harmful interference, and (2) This device must accept any interference received, including interference that may cause undesired operation.

## CANADIAN VERIFICATION



This Class B digital apparatus complies with ICES-003.  
Cet appareil numérique de la classe B est conforme à la norme NMB-003 du Canada.

## EUROPEAN COMMUNITY



This information Technology Equipment has been tested and found to comply with the following European directives:

- (1) EMC Directive 89/336/EEC, amended by directive 93/68/EEC, according to:  
EN55022:1995 (Class B)  
EN55024:1998
- (2) Low Voltage Directive 73/23/EEC amended by 93/68/EEC according to EN 60950:1992 + A11:1997, or EN60950:2000.

## JAPAN



This equipment is Class B (Information Technology Equipment to be used in a residential area or an adjacent area thereto) and conforms to the standards set by the Voluntary Control Council for Interference (VCCI) by Information Technology Equipment aimed at preventing radio interference in such residential area.

When used near a radio or TV receiver, it may become the cause of radio interference. Read instructions for correct handling.

## AUSTRALIA AND NEW ZEALAND



ACN 003 584 914

This device has been tested and found to comply with the limits for a Class B digital device, pursuant to the Australian/New Zealand standard AS/NZS 3548 set out by the Australian Communications Agency.

## TAIWAN

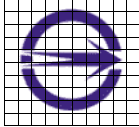

This device has been tested and found to comply with standard CNS 13438, Class B for Electromagnetic Compatibility (EMC) as established by the Taiwan Ministry of Economic Affairs (MOEA), Bureau of Standards, Metrology and Inspection (BSMI).

## Notes



# GLOSSARY

**Adaptive Lossless Data Compression (ALDC)** An advanced data compression algorithm that provides an average compression ratio of 2:1 across multiple data types. *See also* Compression.

**Advanced Metal Evaporated (AME) media** A state-of-the-art tape technology designed for data storage. VXAtape cartridges use AME media.

**American National Standards Institute (ANSI)** Organization that sets standards for SCSI and the safety of electrical devices.

**Bit error rate (BER)** The probability that a transmitted bit will be received in error. The BER is expressed as a ratio of error bits to total number of bits.

**Buffer** A temporary storage area, usually in Random Access Memory (RAM). The tape drive's read and write buffers act as holding areas that enable the tape drive to balance the rate at which it transfers data to or from tape with the data transfer rate of the host. The VXA-2 drive has a 2-MB buffer.

**Bus** In a network, the electrical pathway between a computer and other devices.

**Compression** The reduction in size of data to save space. Either the backup application or the tape drive can perform compression. *See also* ALDC.

**Cyclic redundancy check (CRC)** The error detection technique that checks for uncorrected data during a read operation.

**Discrete Packet Format (DPF)** The format used by the VXA-2 tape drive to read and write data in packet form. Data packets also contain a synchronization marker, unique address information, CRC, and ECC.

**Driver** A program that works with a computer's operating system to operate a peripheral device. Also referred to as a "device driver."

**End of data (EOD)** In a partition, a special format group that is written after all current user data is transferred to the tape.

**Error correction code (ECC)** Error correction codes are generated within the tape drive and recorded with the user data. ECC is used to correct the errors in the user data while being read.

**Exabyte** (1) A network storage backup company that designs, manufactures, and markets industry-leading data storage products including tape drives and automated tape libraries.

(2) measurement of data:

One Exabyte =

1,000 Petabytes, or  
1,000,000 Terabytes, or  
1,000,000,000 Gigabytes, or  
1,000,000,000,000 Megabytes, or  
1,000,000,000,000,000 Kilobytes, or  
1,000,000,000,000,000,000 bytes

**Filemark** A mark on the tape, which is written by the tape drive. A filemark consists of a special recorded element within a partition, containing no user data, which provides a segmentation or location scheme for the data on the tape. Filemarks are typically used during a locate or space operation to move to a particular spot on the tape.

**FireWire** A high-speed serial communication interface that has been certified as a standard by the Institute of Electrical and Electronics Engineers, Inc. (IEEE). The standard contains the electrical specifications and communication protocol necessary to connect various computer peripherals to a host computer.

**Gigabyte** One billion bytes.

**Head** A device that uses induction to write a data pattern onto magnetic media and then uses either inductance or magnetoresistance to read the data back.

**Host** Any type of computer that sends information or commands to a peripheral device, such as the tape drive.

**Initiator** A SCSI device containing application clients that originate device service requests to be processed in a device server. The host typically acts as the initiator of commands.

**LED** Light Emitting Diode. The indicators on the front panel of the tape drive.

**Load** The process of inserting a cartridge into the tape drive. The tape drive automatically loads the tape into the tape path.

**Low Voltage Differential (LVD)** A differential SCSI interface that allows bus lengths up to 12 meters, transfer rates up to 80 MB/sec., and allows single-ended devices to co-exist on the bus.

---

**msec** Millisecond; one-thousandth of a second.

**Mean Time Between Failures (MTBF)** A quantitative measure used to specify the reliability of a drive's mechanics and electronics as a whole under specific environmental conditions, cleanings, and duty cycle.

**Megabyte** One million bytes.

**Noise** Any kind of magnetic or electric interference detected by the electronics.

**OverScan Operation (OSO)** The VXA technique for reading data packets independently of track shape or geometry. By reading packets with multiple scans, OSO ensures that each packet is read at least once.

**Packet** The basic VXA format structure that includes data, ECC, and address and synchronization information.

**Partition** A self-contained area on a tape that can be written and read independently to make more efficient use of the media. The VXA-2 tape drive accommodates two partitions.

**Read-After-Write (RAW)** A process that improves data integrity by reading data immediately after it is written and writing the packet again if an error is found. Individual packets are rewritten as necessary, optimizing speed and capacity.

**SCSI** Small Computer System Interface. A device interface that has been certified as an American National Standard by ANSI. The standard contains the electrical specifications, communication protocol, and command structure necessary to connect various computer peripherals to a host computer.

**SCSI ID** A unique address assigned to each device attached to a SCSI bus. *See also* Bus.

**Segment** The format structures contained within the data buffer. Each segment contains 1,220 packets of data, ECC, and CRC information.

**Setmark** A mark written by the tape drive to allow fast searching to a point on the tape without having to know the number of records or filemarks that precede the point. A setmark is a special recorded element within a partition, that contains no user data, and provides a segmentation scheme hierarchically superior to filemarks for use in addressing or fast positioning on high-capacity storage devices (also called Save-Set Mark).

**Streaming** An operational mode that occurs when the data transfer rate to or from the host closely matches the tape drive's data transfer rate, allowing the tape drive to read or write data in a continuous stream.

**Termination** In SCSI, termination refers to placing a resistor (terminator) at both physical ends of the SCSI bus to prevent signal reflection.

**Transfer rate** The transmission speed of a communications line. The tape drive transfer rates are measured in megabytes per second (MB/sec).

**Variable Speed Operation (VSO)** The VXA technique for adjusting tape motion to match the host transfer rate, eliminating “backhitching.” This technique optimizes backup and restore times, while enhancing media and drive reliability.

**Volume** A recording medium together with its physical carrier (a single tape cartridge).

**VXA** VXA is a breakthrough tape technology that offers previously unobtainable levels of reliability, data availability and interchange, and recoverability, capacity and interchangeability. This is accomplished through the exclusive combination of OverScan Operation (OSO), Variable Speed Operation (VSO) and Discrete Packet Format (DPF).



# INDEX

## A

- AC power connector, location 1-4
- acoustic noise 8-11
- agency labels 1-5, 8-15 to 8-17
- air flow requirements 8-10
- ALDC compression algorithm 8-2
- altitude 8-8
- AME media 8-2
  - See also* cartridges
- ANSI publications x
- application software
  - compatibility 2-11
  - integrating the tape drive 2-11
  - preparing for installation 2-2
  - tape drive problems 4-3
- archival life, media 3-4, 8-2
- Australian Communications Agency declaration 8-17
- auxiliary connector (internal drive)
  - location 1-3
  - using to enable term power 2-4

## B

- backward compatibility 8-2
- bezel
  - See* components, front panel
- bit error rate 8-2 to 8-3
- buffer size 8-2
- Bureau of Standards, Metrology and Inspection (BSMI) declaration 8-17

## C

- Canadian Verification declaration 8-16
- capacities 8-1
- cartons, shipping 8-14
- cartridges
  - archival life 3-4, 8-2
  - capacities 8-1
  - cleaning 3-5
  - compatibility 8-2
  - drive does not accept cartridge 4-1
  - loading 3-4
  - operating environment 8-13
  - retiring 3-4
  - setting the write-protect switch 3-4
  - specifications 8-2
  - tape drive does not eject cartridge 4-2
  - unloading 3-4
  - using 3-3
- chassis grounding 1-3, 2-4
- cleaning
  - instructions 3-5
  - LED indicators 3-2, 3-5
- cleaning wheel 3-5
- command protocol, definition 6-1
- commands supported, SCSI-2 6-2 to 6-3
  - See also* SCSI commands
- communication interface, definition 6-1
- compatibility
  - with software and operating systems 2-11, 4-3
  - with VXA-1 drive 8-2
- compliance, safety and regulatory 8-15 to 8-17

- components, back panel
    - external FireWire model 1-4
    - external SCSI model 1-4
    - internal drive 1-3
  - components, front panel 1-2
  - compression 8-2
  - connectors, back panel
    - external drive 1-4 to 1-5
    - internal drive 1-3
    - See also* AC power connector
    - See also* auxiliary connector
    - See also* FireWire
    - See also* power connector
    - See also* SCSI connector
    - See also* serial connector
  - contacting Exabyte iv
  - cooling 8-10
- D**
- data capacities 8-1
  - data transfer rate 8-2
  - DC voltages 8-6
  - device drivers 2-11, 4-3
  - diagnostic port, location (external model) 1-4
  - diagnostics, performing 4-6, 5-2
  - dimensions 8-4 to 8-5
  - Discrete Packet Format 8-2
  - door
    - loading a cartridge 3-4
    - location 1-2
  - drive bay, installing the tape drive 2-2 to 2-7
- E**
- eject button
    - doesn't eject cartridge 4-2
    - location 1-2
    - using to eject cartridge 3-4
  - enclosure, installing the tape drive 2-2 to 2-7
  - environmental specifications 8-8 to 8-12
  - error
    - LED indicators 3-2
    - reported in software 4-5
  - error detection and correction 8-2
  - error rate 8-2 to 8-3
  - ESD protection 2-2, 2-4
  - European Community declaration 8-16
  - Exabyte, contacting iv
  - external drive
    - installing the FireWire drive 2-9 to 2-10
    - installing the SCSI drive 2-7 to 2-9
- F**
- FCC declaration 8-16
  - FireWire
    - cable and connector requirements 7-4
    - connector location (external model) 1-4
    - operating system support 2-9 to 2-10
    - tape drive installation 2-9 to 2-10
  - firmware, upgrading 5-2
  - form factor 8-4
  - format, read and write 8-2
  - front panel
    - See* components, front panel
  - fuse, resettable power 2-4
- G**
- grounding hole and tab (internal model)
    - location 1-3
    - using to ground drive 2-4
- H**
- heads 8-2
  - host bus adapter, SCSI 2-2
  - humidity
    - specification 8-8
  - HVD (high voltage differential) bus caution 7-1
- I**
- ID jumper block
    - See* SCSI ID jumper block
  - ID switch
    - See* SCSI ID switch
  - installing software 2-2, 2-11, 4-3
  - integrating the tape drive into a system 2-11
  - internal tape drive, installing 2-2 to 2-7

**J**

## jumpers

- using to set SCSI ID 2-3
- using to set term power 2-4

**L**

## labels 1-5

## LEDs

- cleaning indicator 3-5
- definition of all states 3-2 to 3-3
- location 1-2
- over-temperature indicator 3-2, 4-2
- power-on sequence 2-6, 2-9
- service indicator 3-2, 4-4
- load cycles specification 8-3
- load/unload time 8-3
- LVD SCSI requirements 7-1 to 7-4

**M**

- mean time between failures (MTBF) 8-3
- mean time to repair (MTTR) 8-3
- media
  - See* cartridges
- messages, SCSI 6-6
- mid-tape reposition time 8-3
- model number 1-5
- models 1-1
- mounting configurations for the internal model 2-6
- mounting orientation 1-1, 2-2

**N**

- noise levels 8-11

**O**

## on/off switch

*See* power switch

- operating environment 8-8 to 8-13
- operating system
  - compatibility 2-11
  - integration problems 4-3
  - tape drive problems 4-3

- operating the tape drive 3-1 to 3-6
- overvoltage protection 8-6

**P**

- packaging specifications 8-14
- packing the tape drive 5-1
- part number for drive, locating 1-5
- particulate contamination limits 8-11
- partitions 8-2
- performance specifications 8-2
- pin assignments
  - power connector 8-5
  - SCSI connector 7-3
- POST 2-6, 2-9, 3-2
- power cable
  - connecting to external FireWire drive 2-10
  - connecting to external SCSI drive 2-9
  - connecting to internal drive 2-6
- power connector
  - location (external model) 1-4
  - location (internal model) 1-3
  - pin assignments 8-5
- power LED, location (external model) 1-2
- power specifications
  - AC power consumption, external tape drive 8-7
  - DC voltages, internal tape drive 8-6
  - power connector requirements, internal tape drive 8-5
  - power consumption, internal tape drive 8-7
  - power supply, external tape drive 8-7
- power switch (external model) 1-4
- product identification, changing for software compatibility 2-11
- publications, related x

**R**

- read and write specifications 8-2
- read reliability 8-3
- Reed Solomon error detection 8-2
- regulatory standards 8-15 to 8-17
- reliability specifications 8-3
- reposition time 8-3

- resetting the tape drive 3-6
  - retiring cartridges 3-4
  - returning drive for service 5-1
  - RF service connector, internal model 1-3
- S**
- safety and regulatory compliance 8-15 to 8-17
  - SCSI
    - command protocol overview 6-2 to 6-6
    - message system 6-6
    - sense keys 6-4
    - supported commands 6-2 to 6-3
  - SCSI bus reset 3-6
  - SCSI cable
    - connecting to external model 2-8
    - connecting to internal model 2-4
    - specifications for external drive 7-4
    - specifications for internal drive 7-2
  - SCSI communication interface 7-1 to 7-4
  - SCSI connectors
    - location (external model) 1-4
    - location (internal drive) 1-3
    - pin assignments 7-3
    - specifications for internal drive 7-2 to 7-3
  - SCSI ID
    - setting (external model) 2-8
    - setting (internal model) 2-3
  - SCSI ID jumper block (internal model)
    - location 1-3
    - using to set SCSI ID 2-3
  - SCSI ID switch (external model)
    - location 1-4
    - using to set SCSI ID 2-8
  - SCSI messages 6-6
  - SCSI term power, enabling 2-4
  - SCSI terminator
    - installing, external drive 2-8
    - installing, internal drive 2-5
    - requirements for external drive 7-4
    - requirements for internal drive 7-4
  - search speed 8-3
  - sense keys, definitions 6-4 to 6-5
  - serial connector, location (external model) 1-4
  - serial number for drive 1-5
  - service connector, internal model 1-3
  - service life 8-3
  - service, returning drive iv, 5-1
  - shipping specifications 8-14
  - shipping the tape drive 5-1
  - shock specifications 8-11
  - single-ended bus, recommendations
    - against 7-2
  - size of drive 8-4 to 8-5
  - software
    - See application software
  - sound levels 8-11
  - specifications for drive 8-1 to 8-17
  - speed 8-2
  - status bytes supported 6-4
  - storage environment
    - cartridges 3-4
    - tape drive 8-8
- T**
- tape
    - See cartridges
  - tape drive
    - installing 2-1 to 2-10
    - integrating 2-11
    - operating system and software
      - compatibility 2-11
    - operating temperature and
      - humidity 8-8 to 8-10
    - product identification 2-11
    - troubleshooting 4-1 to 4-6
    - upgrading firmware 5-2
  - tape speed 8-3
  - Technical Support iv
  - temperature data, stored in drive 8-10
  - temperature range 8-8
  - term power, enabling 2-4
  - termination
    - external drive 2-8
    - internal drive 2-5
  - transfer rate 8-2
  - troubleshooting 4-1 to 4-6
  - TUV Product Service declaration 8-15

**U**

Underwriters Laboratory declaration 8-15  
unload button  
    *See* eject button  
unload/load time 8-3  
unpacking 2-1  
upgrading firmware 5-2

**V**

vibration specifications 8-12  
voltage specifications 8-7  
voltages, DC power 8-6  
VXA-1 compatibility 8-2  
VXA2Tool, using 4-6, 5-2  
VXAtape  
    *See* cartridges

**W**

weight of drive 8-4  
wet bulb 8-8  
write and read specifications 8-2  
write reliability 8-3  
write-protect switch 3-4

## Notes