

⚠ WARNING

- For Outdoor Use Only (outside any enclosure)
- This instruction manual contains important information necessary for proper assembly and safe use of this appliance.
- Read and follow all warnings and instructions before assembling and using the appliance.
- Follow all warnings and instructions when using the appliance.
- Keep this manual for future reference.

⚠ DANGER

- If you smell gas:
 1. Shut off gas to the appliance.
 2. Extinguish any open flames.
 3. Open the lid.
 4. If the odor continues, keep away from the appliance and immediately call your fire department.Failure to follow these instructions could result in fire or explosion which could cause property damage, personal injury, or death.
- Never operate this appliance unattended.
- Do not store or use gasoline or other flammable liquids or vapors in the vicinity of this or any other appliance.
- An LP cylinder not connected for use shall not be stored in the vicinity of this or any other appliance.
- Check for leaks every time prior to lighting the grill, even if purchased fully assembled. Gas leaks may cause a fire or explosion. Please read the instructions on page 8.

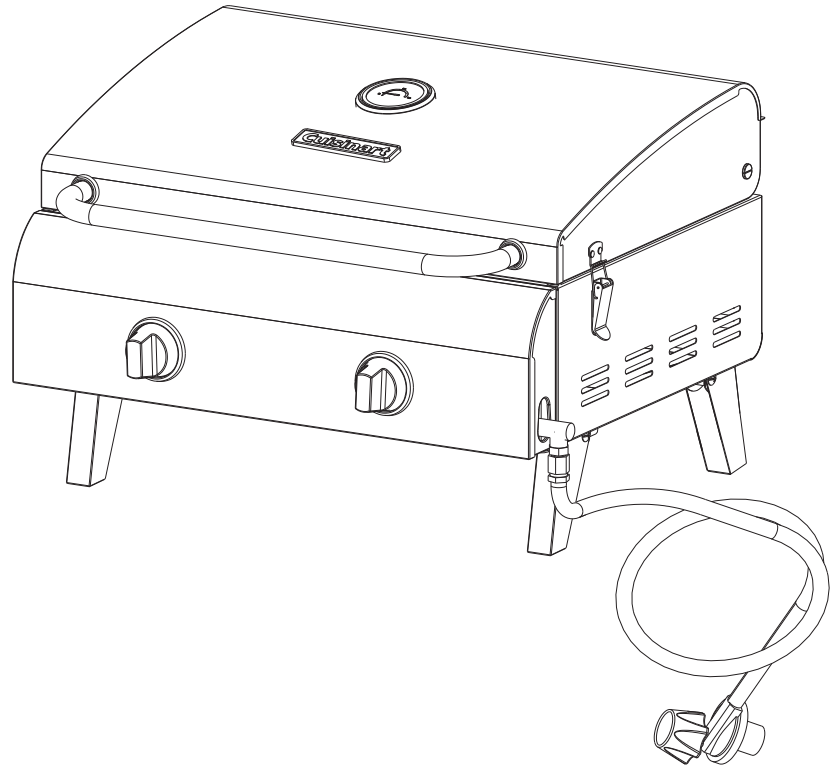

Customer Service Hotline

1-866-994-6390

DO NOT RETURN YOUR GRILL TO THE STORE
Before visiting your local retailer, call our customer service department at 1-866-994-6390 from 9:00 am to 5:00 pm Eastern Time, Monday through Friday.

Table of Contents

Table of Contents	2
Safety Information	3
Package Contents List	5
Preparation	5
Assembly Instructions	6
Installation Instructions	7
Operation Instructions	10
Care and maintenance	12
Troubleshooting	14
Replacement Parts List	15
Questions?	Back Cover

SAFETY INFORMATION

Please read the following instructions carefully before attempting to assemble, operate or install the product. Failure to follow these instructions may result in serious bodily injury and/or property damage. If you have questions regarding the product please call customer service at 866-994-6390, 9 a.m.-5 p.m., EST, Monday-Friday or email consumercare@thefulhamgroup.com.

LP- gas supply cylinder to be used must be constructed and marked in accordance with the specifications for LP-gas cylinders of the U.S Department of Transportation (DOT) or the National Standard of Canada, CAN-B339, Cylinders, Spheres and Tubes for the Transportation of Dangerous Goods

1. The installation must conform with local codes or, in the absence of local codes, with the National Fuel Gas Codes, with the National Fuel Gas Code, ANSI Z223.1/NFPA 54, Storage and Handling of Liquefied Petroleum Gases, ANSI/NFPA 58.
2. Table top grill is for outdoor use only. Grill should be operated in a well-ventilated space. Never operate in an enclosed space, garage or building. Your grill is not intended to be installed in or on recreational vehicles and / or boats .
3. Heated liquids remain at scalding temperatures long after the cooking process. Do not touch the cooking appliance until liquids have cooled to 115°F (45°C) or less.
4. Do not install or use grill within 36" of combustible materials from back and sides of grill. Grill shall not be located under overhead surfaces (closed carport, garage, porch, patio) that can catch fire.
5. Never attempt to attach this grill to the self-contained LP gas system of a camper trailer or motor home.
6. It is the responsibility of the assembler/owner to assemble, install and maintain gas grill. Do not let children and pets operate or play near your table top grill. Failure to follow these instructions could result in serious personal injury and/ or property damage.
7. Open lid before lighting grill. When grill is not in use, turn off control knob on LP gas cylinder.
8. Carefully follow instructions in this manual for proper assembly and leak testing of your grill. Do not use grill until leak checked. If leak is detected at any time, it must be stopped and corrected before using grill further.
9. Appliance area should be kept clear and free from combustible materials, gasoline, bottled gas in any form and other flammable vapors and liquids. Do not obstruct flow of combustion and ventilation air.
10. Never try to light grill with lid closed! Buildup of gases is very dangerous and could cause an explosion
11. Keep any electrical cord of fuel supply hose away from any heated surfaces
12. Propane is a flammable gas and improper handling may result in explosion and/or fire and serious accident or injury.
13. This appliance will be hot during and after use. Use insulated oven mitts or gloves for protection from hot surfaces or splatter from cooking liquids
14. Do not leave your grill unattended while in operation
15. Do not use while under the influence of drugs or alcohol.
16. Do not store any spare LP (propane) cylinder, full or empty, under or near your grill.
17. Appliance is not intended for commercial use or rental
18. The cylinder must be disconnected when the appliance is not in use

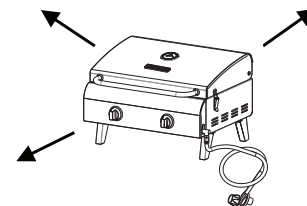

NATURAL HAZARD • SPIDERS

FACT: Sometimes spiders and other small insects climb into the burner tube. The spiders spin webs, build nests and lay eggs. The webs or nests can be very small, but they are very strong and can block the flow of gas. Clean burner prior to use after storing, at the beginning of grilling season or after a period of one month not being used

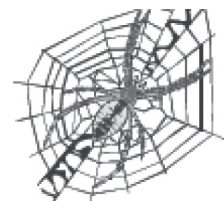

SAFETY INFORMATION

The Fuel System

Gas grills are used safely by millions of people when following simple safety precautions.

The items in the fuel system are designed for operation with this grill. They must not be replaced with any other brand. (See parts list for replacement items.)

GAS BURNER: The gas burner is constructed of stainless steel and should not require maintenance other than inspection for insects/nests inside the air intake slots.

FUEL SUPPLY HOSE

The hose connected regulator provided with this appliance is 38 inches length. Keep the fuel hose away from any heated surface(s).

PROPANE FUEL: Warning - propane is a flammable gas. Improper handling may result in an explosion and/or fire and serious accident or injury. Your grill is designed to operate with propane (LP) gas only and is equipped with the proper orifice for propane gas.

Caution: Do not connect this grill with any gas supply other than propane. Propane gas is heavier than air and settles in lower areas. Make certain adequate ventilation is available when using your grill. The gas cylinder may be stored outside in a well-ventilated area out of the reach of children when the grill is not in use. If the appliance is not in use, the gas must be turned off at the supply cylinder.

The LP gas cylinder shall be used only outdoors in a well-ventilated space and not in a building, garage, or any other enclosed area. The Portable Gas Grill may be stored indoor if the LP gas cylinder is removed and stored outdoor. The LP gas cylinder (not included) is threaded for connection directly to the gas regulator supplied with this appliance. Care should be taken when threading the cylinder to the regulator to engage threads correctly to achieve the proper and intended connection. When disconnecting or connecting the gas cylinder, be careful that the regulator does not strike the grill, the ground, or any other surfaces. Replace the protective cap over the threaded cylinder connection when removed from grill. If any difficulty occurs when connecting or disconnecting the cylinder to the regulator assembly, contact your local gas supplier for assistance.

When re-connecting the LP gas cylinder to the regulator, be sure to hand-tighten until snug. This connection should be inspected for damage and leak tested after each re-connection.

To Leak Test, make a soap solution of one part liquid detergent and one part water. You will need a spray bottle, brush, or rag to apply the solution to the fitting. Bubbles indicate leaks.

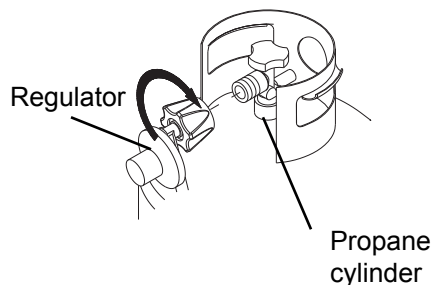



Check all gas supply fittings for leaks before each use. Do not use the grill until all connections have been checked and do not leak.



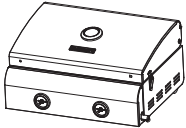
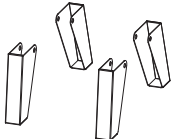

SAFETY INFORMATION

⚠ WARNING

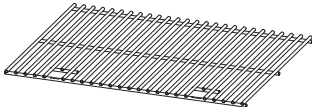
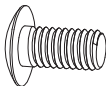
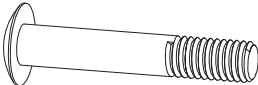
- Always operate the grill on a tabletop, no higher than 32 inches.
- Place the propane tank on the ground immediately adjacent to the tabletop, no less than 24 inches from the grill.
- Failure to follow these instructions could cause the propane tank to overheat and vent propane which could ignite causing serious personal injuries or property damage and/or a tripping hazard over the gas hose or propane tank, pulling the grill off the tabletop causing serious personal injuries or property damage.

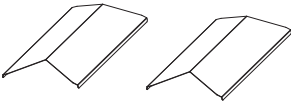
PACKAGE CONTENTS

PART	DESCRIPTION	QTY
1	 Grill body	1pc
2	 Foldable leg	4pc
3	 Control knob	2pc
4	 Cooking grid	1pc
PART	DESCRIPTION	QTY
A	 M6X12 screw	2pc
B	 Leg hinge screw	4pc

PART	DESCRIPTION	QTY
5	 Flame tamer	2pc
6	 Grease tray	1pc
7	 Handle	1pc
8	 Handle bezel	2pc
PART	DESCRIPTION	QTY
C	 Hex nut	4pc

PREPARATION

Before beginning assembly, installation or operation of product, remove all packaging material and make sure all parts are present. If any part is missing or damaged, do not attempt to assemble, install or operate the product. Contact customer service for replacement parts.

- Estimated Assembly Time: 25 minutes.

Warning: this appliance is not intended for and should never be used as a heater.

ASSEMBLY INSTRUCTIONS

STEP 1

- Attach 4 legs (2) to the bottom side of the grill (1) using one leg hinge screw (B) and hex nut (C) per leg as shown. Use a Philips head screw driver and wrench to fully tighten.

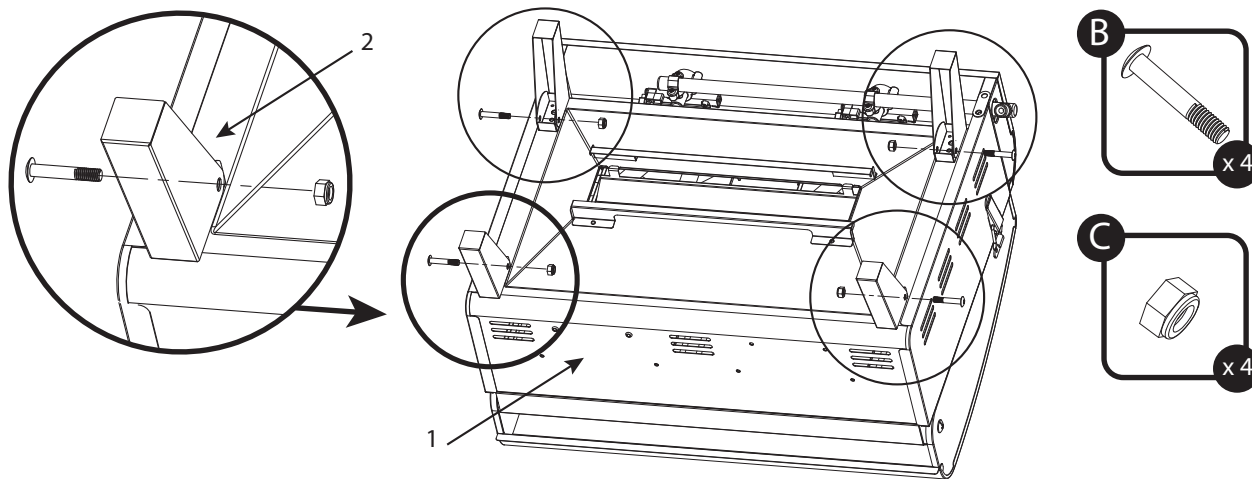

STEP 2

- Attach the lid handle (7) and lid handle bezels (8) to the front of the lid using 2 M6x12 screws (A) as shown below.

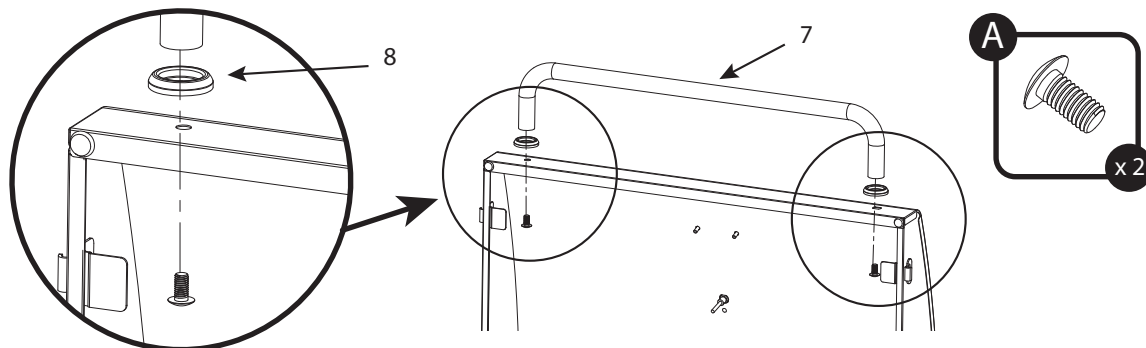

STEP 3

- Place and push control knobs (3) on to the control panel.
- Place flame tamers (5) and cooking grid (4) in to the grill as shown below.

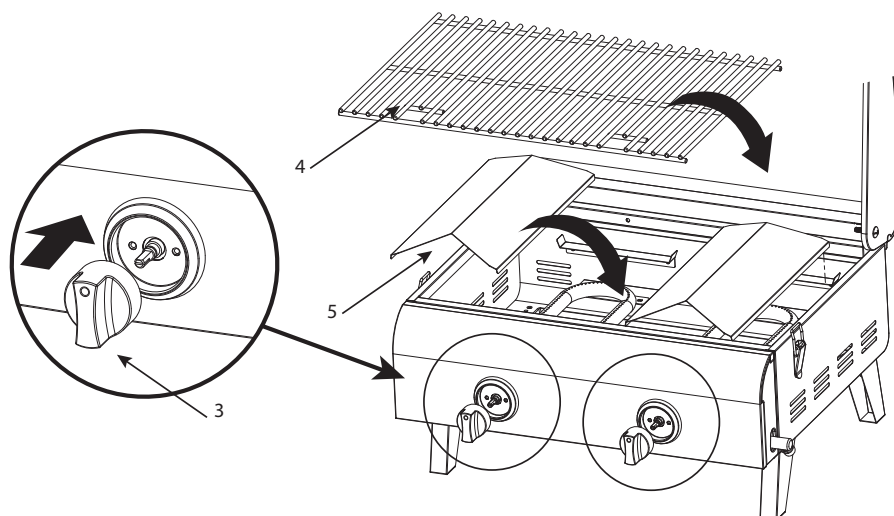

ASSEMBLY INSTRUCTIONS

STEP 4

- Insert the grease tray (6) in to the track on the bottom of the grill as shown below.

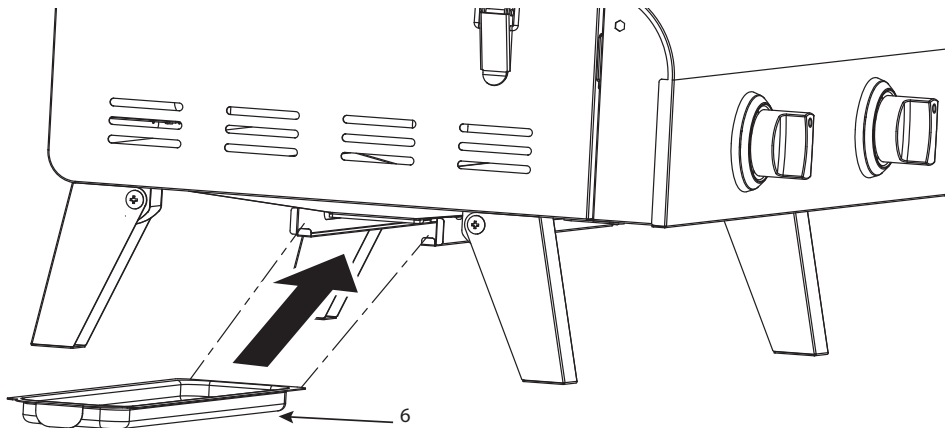

Figure 1

1. Attach regulator with 38" LP gas hose to the propane cylinder by turning the regulator handle clockwise as shown in Fig 1. If the grill is not in use, the gas must be turned "OFF" at the propane cylinder.

Check all gas supply fittings for leaks before each use. Do not use the grill until all connections have been checked and do not leak (see "Leak Testing" instructions on page 9).

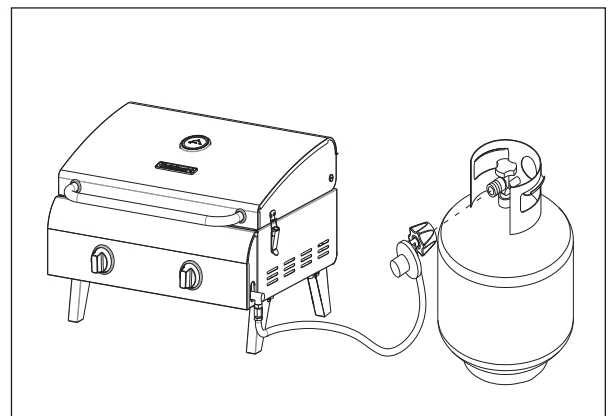
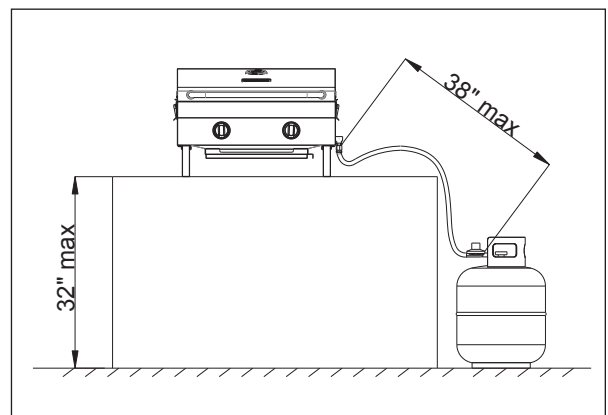

Figure 2

2. Place the table top on the desk as shown in Fig.2.

Note: This table top grill is use with 38" gas hose, we suggest to use this grill on a 32" high table.



INSTALLATION INSTRUCTIONS

GAS HOOK-UP

Only the pressure regulator and hose assembly supplied with the grill should be used. Any replacement pressure regulator and hose assembly must be specified by the grill manufacturer. This grill is configured for Liquid Propane. Do not use a Natural Gas supply.

Total gas consumption (per hour) with all burners set on “HI”:

Main burners	20,000 BTU/Hr.
Total	20,000 BTU/Hr.

The installation of this appliance must conform with local codes or, in the absence of local codes, with either the National Fuel Gas Code, ANSI Z223.1/NFPA 54, National Gas Propane Installation Code, CSA B149.1, or Propane Storage and Handling Code, B149.2.

LIQUID PROPANE CYLINDER REQUIREMENTS (20-lb Cylinder)

A dented or rusty Liquid Propane cylinder may be hazardous and should be checked by your supplier. Never use a cylinder with a damaged valve. The Liquid Propane cylinder must be constructed and marked in accordance with the specifications for Liquid Propane cylinders by the United States Department of Transportation (DOT) or the National Standard of Canada, CAN/CSA-B339, Cylinders, Spheres and Tubes for Transportation of Dangerous Goods Commission.

The 20-lb cylinder must have a shut off valve terminating in a valve outlet specified, as applicable, for connection type QCC1 in the standard for compressed gas cylinder valve outlet and inlet connection ANSI/CGA-V-1.

Storage of an outdoor cooking gas appliance indoor is permissible only if the cylinder is disconnected and removed from the outdoor cooking gas appliance. The cylinder system must be arranged for vapor withdrawal. The cylinder must include a collar to protect the cylinder valve.

Manifold pressure: (operating) 11 inches water column (W.C.), (non-operating) 11.2 inches water column (W.C.).

The Liquid Propane cylinder must be fitted with an Overfill Protection Device (OPD).

Remove the plastic valve cover from the Liquid Propane cylinder. Make sure the grill gas hoses do not contact the grease pan or grill firebox when the Liquid Propane cylinder is placed into the cart.

CONNECTING THE LIQUID PROPANE CYLINDER

- To connect the Liquid Propane gas supply cylinder:
- The cylinder valve should be in the “OFF” position. If not, turn the valve clockwise until it stops.
- Make sure the cylinder valve has the proper type-1 external male thread connections per ANSI Z21.81.
- Make sure the burner valves are in the “OFF” position.
- Inspect the valve connections, port and regulator assembly. Remove debris and inspect the hose for damage.
- When connecting the regulator assembly to the valve, use your hand to tighten the nut clockwise until it stops. Use of a wrench could damage the quick coupling nut and result in a hazardous situation
- Open the cylinder valve fully by turning the valve counterclockwise.
- Before lighting the grill, use a soap and water solution to check all the connections for leaks.
- If a leak is found, turn the cylinder valve “OFF” and do not use the grill until a local Liquid Propane dealer can make repairs.

INSTALLATION INSTRUCTIONS

DISCONNECTING THE LIQUID PROPANE CYLINDER

- Turn the grill burner valves “OFF” and make sure the grill is cool.
- Turn the Liquid Propane cylinder valve “OFF” by turning clockwise until it stops.
- Detach the regulator assembly from the cylinder valve by turning the quick coupling nut counterclockwise.
- Place dust cap on cylinder valve outlet whenever the cylinder is not in use. Only install the type of dust cap on the cylinder valve outlet that is provided with the cylinder valve. Other types of caps or plugs may result in leakage of propane.

LEAK TESTING – GENERAL

Although gas connections on the grill are leak tested prior to shipment, a complete leak test must be performed at the installation site. Before each use, check all gas connections for leaks using the procedures listed below.

If the smell of gas is detected at any time, you should immediately check the entire system for leaks.

BEFORE TESTING

Make sure all packing materials have been removed from the grill, including the burner tie-down straps.

WARNING

Check all gas supply fittings for leaks before each use. Do not use the grill until all connections have been checked and do not leak. Do not smoke while leak testing. Never leak test with an open flame.

Make a solution of one part liquid detergent and one part water. You will need a spray bottle, brush, or rag to apply the solution to the fittings. For the initial leak test, make sure the Liquid Propane cylinder is full.

TO TEST

1. Turn the burner valves off.
2. Turn the Liquid Propane cylinder valve counterclockwise to open the valve.
3. Apply the soap solution to all gas fittings. Soap bubbles will appear where a leak is present.
4. If a leak is present, immediately turn the gas supply “OFF” and tighten leaky fittings.
5. Turn the gas back “ON” and recheck.
6. Should the gas continue to leak from any of the fittings, turn the gas supply “OFF” and contact customer service at 866-994-6390 or email consumercare@thefulhamgroup.com.
7. If there is evidence of excessive abrasion or wear, or the hose is cut, it must be replaced prior to the outdoor cooking gas appliance being put into operation.

Only those parts recommended by the manufacturer should be used on the grill. Substitutions will void the warranty.

WARNING

Do not store grill indoors unless the cylinder is disconnected. Do not store cylinder in a building, garage, or any other enclosed area, and keep out of reach of children at all times.

INSTALLER FINAL CHECK

Maintain specified clearance of 36 inches from combustible materials and construction.

- All internal packaging has been removed.
- The hose and regulator are properly connected to the Liquid Propane cylinder.
- The unit has been tested and is free of leaks.
- The gas supply shutoff valve has been located.
- All burners are installed.
- Keep the instruction manual for future reference

INSTALLATION INSTRUCTIONS

⚠ WARNING

1. The grill and its individual shutoff valve must be disconnected from the gas supply piping system during any pressure testing of that system at test pressure in excess of 1/2-in.PSI (3.5kpa).
2. The outdoor cooking gas appliance must be isolated from the gas supply piping system by closing its individual manual shutoff valve during any pressure testing of the gas supply piping system at test pressure equal to or less than 1/2-in.PSI (3.5kpa).

⚠ WARNING

1. Do not store spare Liquid Propane cylinders under or near this appliance.
2. Never fill the cylinder beyond 80 percent capacity.
3. If the information in item 1&2 is not followed exactly, a fire causing death or serious injury may occur.

OPERATING INSTRUCTIONS

LIGHTING THE GRILL

1. Place the legs in up position.
2. Make sure the propane cylinder is tightly threaded into the regulator (hand tighten only).
3. Open lid. Always open lid when lighting.
4. Push and turn Main burner knob slowly to IGNITE/Hi as show in Fig.4, burner should light immediately.
5. If ignition does not occur in 3-5 seconds, turn the control knob "OFF". Wait 5 minutes before attempting to re-light the grill. If the grill fails to ignite after the second attempt, call customer service at 1-866-994-6390 for assistance. With burner lit, gently close the lid and allow the grill to warm up for 5 minuets prior to use.

Note: If the knob can't spark insert the match into the lighting rod as show in Fig.5. Ignite the match and insert though the cooking grids to the burner.

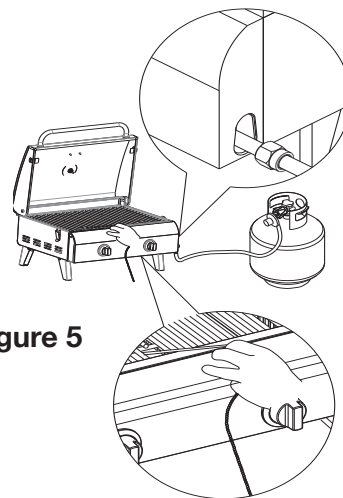
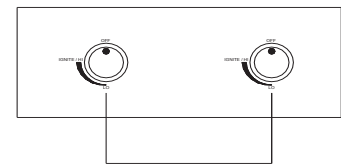

Figure 5

TURNING THE GRILL OFF

1. Turn knob to "OFF" position.
2. Turn the propane cylinder control knob to the "OFF" position.
Caution: Do not attempt to re-light the grill without following all the lighting instructions.
3. Allow the grill body to cool at least 30 minutes before attempting to move or transport.
4. Remove and clean grease tray prior to transporting, then reinstall.

Figure 4



Main Burners

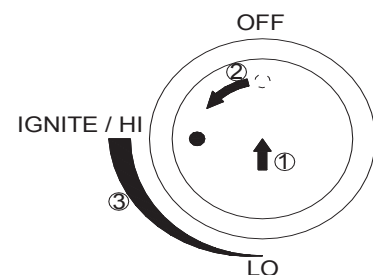

1. Push
2. Turn knob to Ignite/Hi
3. Adjust flame

OPERATING INSTRUCTIONS

FLAME CHARACTERISTICS

- Check for proper burner flame characteristics. Burner flames should be blue and stable with no yellow tips, excessive noise, or lifting as shown in Fig. 6.
- Turn the control knobs and Liquid Propane cylinder valves “OFF.”
- Allow the grill and burners to cool.

Figure 6

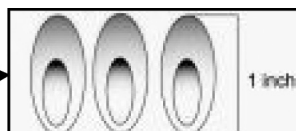

Visually check the burner flames prior to each use, the flames should look like this picture, if they do not, refer to the burner main tenancy part of this manual.

USING THE GRILL

1. Find a level surface to grill on.
2. Allow the grill to warm up with the lid closed for 5 minutes prior to cooking.
3. You may cook on the grill in any weather. If the temperature is extremely cold or hot, the cooking times will be slightly increased or decreased. Keep the grill out of excessive winds when operating.

CARE AND MAINTENANCE

There is very little care and maintenance needed. The Portable Gas Grill is designed and made of materials that will last many years with normal use. Following these instructions will improve the longevity and quality of cooking. To ensure safe operation of your grill, the area of cooking should always be kept free of combustible materials of any type, such as gasoline or other flammable vapors or liquids.

Outside Grill Parts - This is stainless steel. It can be cleaned easily with warm soapy water or any stainless steel cleaner.

Cooking Grid and Grease Tray – The cooking grid is made of stainless steel. The cooking grid should be brushed with a steel brush immediately after cooking, while the grill is still warm. The grease tray is also stainless steel and can be cleaned with a flat scraper such as a putty knife.

Caution: The grease tray must be kept clean and free of heavy buildup for the grill to perform properly and to eliminate flare-ups.

Grill Main Burners - Extreme care should be taken when removing a burner. It must be correctly centered on the orifice before any attempt is made to relight the grill. Frequency of cleaning will depend on how often you use the grill.

Failure to properly place the burner over the orifice could cause a fire to occur behind and beneath the valve panel, thereby damaging the grill and making it unsafe to operate. Before cleaning, make sure the gas supply and control knobs are in the “OFF” position and the burners have cooled.

To remove the main burners for cleaning:

1. Locate the burner screw at the rear of the firebox.
2. Remove the screw and lift the burner out of the firebox.

To clean the grill burners:

1. Clean the exterior of the burner with a wire brush. Use a metal scraper for stubborn stains or debris.
2. Clear clogged ports with a straightened paper clip. Never use a wooden toothpick as it may break off and clog the port.
3. Check and clean burners / venturi tubes for insects and insect nests. A clogged tube can lead to a fire beneath, and behind the main control panel.

To reinstall the main burners:

1. Insert the burner over the main burner gas valve (part# 11 on page 14).
2. Make sure the orifice spud (A) is inside the burner venturi (B) as shown in Fig. 7.
3. Align the burner screw hole with the firebox hole, insert screw and tighten.

Firebox - Use warm soapy water to clean this area. Do not allow grease to build up.

Drain Hole – The drain hole must be kept clear of grease and food particles to allow drippings to drain properly into the grease tray. This must be done to maintain proper operation of your grill.

General - This grill, like all equipment, will look better and last longer if kept out of the weather when not in use.

Caution: Do not store propane cylinders in enclosed areas. When using a cover or moving the grill, always wait until the grill has cooled for at least 30 minutes.

- Not obstruct the flow of combustion and ventilation air.
- A clogged tube can lead to a fire beneath the appliance.

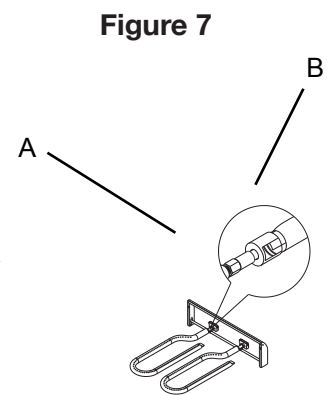

CARE AND MAINTENANCE

This unit **must** be kept in an area free from combustible materials, gasoline and other flammable vapors and liquids.

Make sure all openings into the grill body are free of blockages or debris and there are no objects or materials blocking the flow of combustion or ventilation. Make sure the legs are in the up position when using the grill.

Check burner air inlet openings (behind the inlet guard on the right end of the grill body) for insect nests or blockages. Make sure the slots in the burner tube are clear.

When the grill is not in use, turn the control knob to the “OFF” position and remove the propane cylinder from the regulator. Remove the regulator from the burner.

For outdoor use only, if stored indoors, detach propane cylinder and store outdoors. Propanecylinders must be stored out of reach of children.

IMPORTANT

First-time use: It is important that the grill be lit and allowed to heat up for at least 30 minutes before any food is placed on the cooking grid. It is normal for some smoke to appear during the initial operation of the grill. After initial heating, the grill is ready for use. A cooking spray can be used on the cooking grids to allow easier clean up.

THIS COOKING APPLIANCE IS FOR OUTDOOR USE ONLY AND SHALL NOT BE USED IN A BUILDING, GARAGE OR ANY OTHER ENCLOSED AREA.

MOVING INSTRUCTIONS

Caution: Never move the grill with burner lit.

- Make sure control knob is in the “OFF” position. Disconnect the propane cylinder from the regulator.
- Be sure the grill has completely cooled for at least 30 minutes.
- Close the lid and secure the latch. Remove and clean grease tray, then reinstall. Place the legs in the down position. Use the handle to carry the grill.

Note: It is best to leave the grease tray in place attached to the bottom of the grill-some grease may continue to drip from drain hole during transport.

TROUBLESHOOTING

WARNING

Spiders and insects can nest inside the burners of the grill and disrupt gas flow. This very dangerous condition could cause a fire behind the valve panel, thereby damaging the grill and making it unsafe for operation. Inspect the grill at least twice a year.

When to Look for Spiders

You should inspect the burners at least twice a year or immediately after any of the following conditions occur:

- The smell of gas in conjunction with burner flames appearing yellow.
- The grill does not reach temperature.
- The grill heats unevenly.
- The burners make popping noises.

BEFORE CALLING FOR SERVICE

If the grill does not function properly, use the following checklist before contacting customer service.

Problems	What To Do
Grill will not light.	<ul style="list-style-type: none">• Check to see if the liquid propane cylinder is empty.• Check burner ports for any blockage. Use a soft wire brush to clear plugged ports.• Check the gas orifice on the burner for an obstruction. If orifice is blocked, clean with a needle or thin wire. NEVER USE A WOODEN TOOTHPICK.
Burner flame is yellow or orange in conjunction with gas odor.	<ul style="list-style-type: none">• Check for spiders and insects• Call customer service at 866-994-6390 or email Consumercare@thefulhamgroup.com
Low heat with the control knob on the "HI" setting.	<ul style="list-style-type: none">• Make sure the grill area is clear of dust.• Make sure the burner and orifice are clean.• Check for spiders and insects.• Is there adequate gas supply available?• Is the grill being preheated for 15 minutes?

PART LIST

For replacement parts, call our customer service department 866-994-6390, 9 a.m.-5 p.m., EST, Monday-Friday or email Consumercare@thefulhamgroup.com. NOTE: Not all parts are replacable.

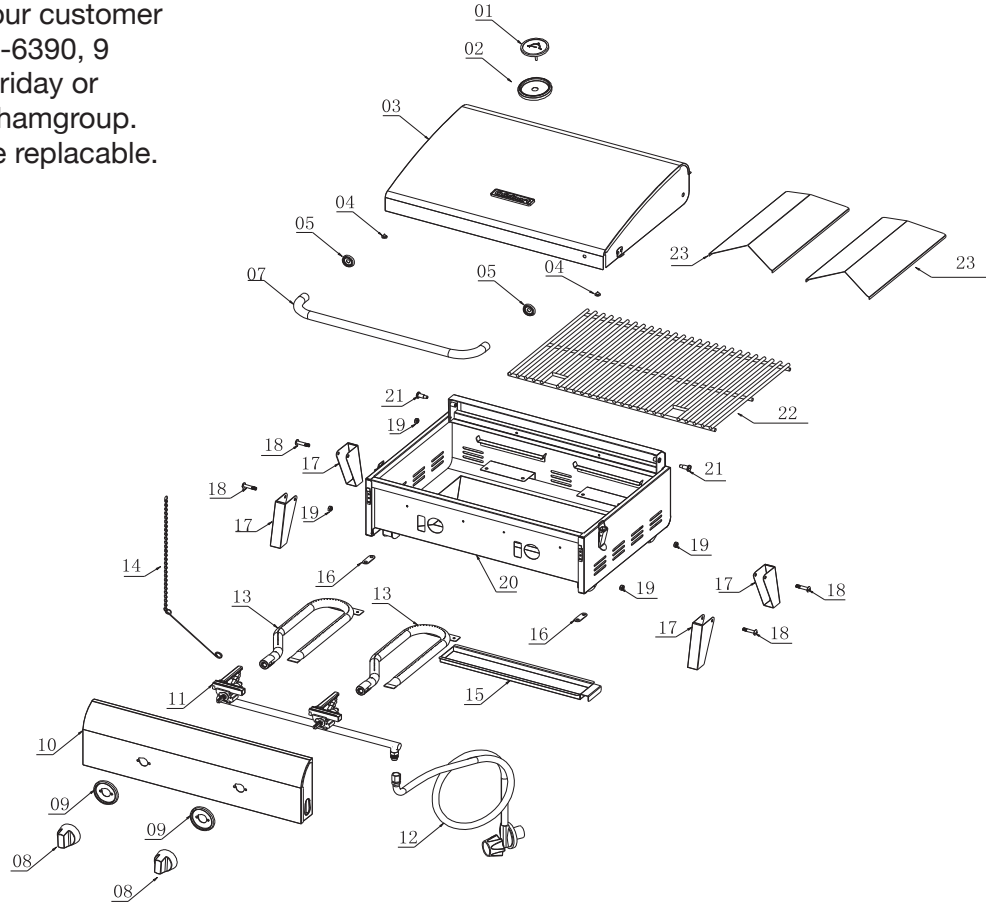

Part	Description	Part #
1	Thermometer	1
2	Thermometer Bezel	1
3	Grill Lid	1
4	Lid Bumper	1
5	Lid Handle Bezel	1
6	Lid Handle Insulating Spacer	1
7	Lid Handle	1
8	Knob	2
9	Bezel	2
10	Control Panel	1
11	Valve and Manifold Assembly	1
12	Regulator	1

Part	Description	Part #
13	Main burner	2
14	Match Light Tool	1
15	Grease Tray	1
16	Control Panel Bracket	2
17	Foldable leg	4
18	Leg Hinge Screw	4
19	Hex Screw	4
20	Fire Box	1
21	Lid Hinge Screw	2
22	Cooking Grate	1
23	Flame Tamer	2

WARNING: when the grill is not use, the regulator must hang on the side of the firebox.

WARRANTY AND REPLACEMENT PARTS

This warranty covers defects in parts and workmanship for a period of 3 years from the original purchase date. Any damage claim regarding the enameling must be submitted within 30 days of purchase to be covered by the warranty.

The following conditions are NOT covered by this warranty:

- Unevenness and color variations in the coated surfaces.
- Damage caused by improper assembly or disregard of the manual.
- Use of spare parts not supplied by manufacturer.
- Damage resulting from modifications or inappropriate use.
- Abuse of the grill
- Damage caused by improper maintenance or repairs by an unauthorized person.

Limitations and exclusions:

1. This warranty applies only to the original purchaser and may not be transferred.
2. If you can not verify the purchase date of the grill the warranty period will begin on the date the grill was manufactured.
3. Replacement or repair parts are warranted for the remaining period of the original part warranty.

Your obligations:

This grill must be assembled, installed, operated and maintained in accordance with all applicable codes and the instruction manual furnished with this grill. You must keep an invoice, cancelled check or payment record to verify the purchase date of the grill.

Questions, problems, missing parts? Before returning to your retailer, call our customer service department at 866-994-6390, 9 a.m.-5 p.m., EST, Monday-Friday or email Consumercare@thefulhamgroup.com.

**Model#CGG-306
North American Distributor:
The Fulham Group
Newton, MA 02466**