

# g

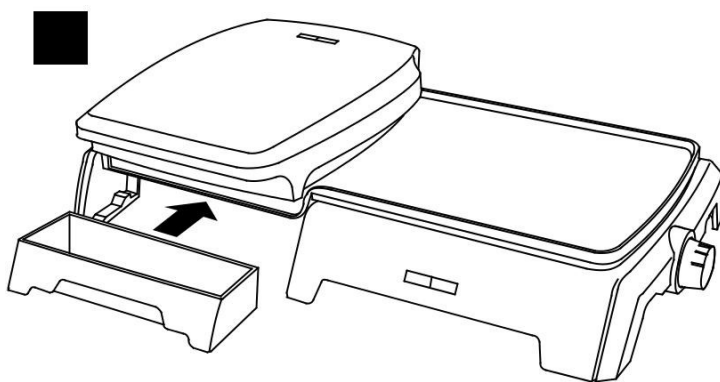

**instructions**

h b

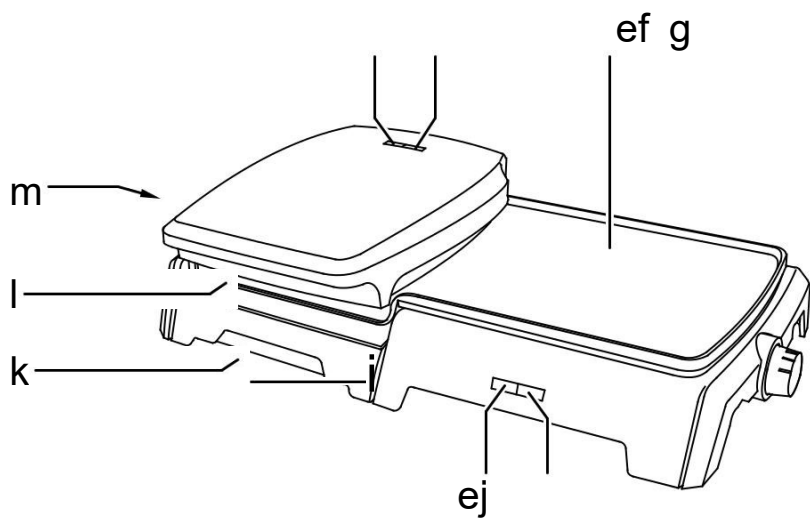

Read the instructions, keep them safe, pass them on if you pass the grill on.

Remove all packaging before use.

## **IMPORTANT SAFEGUARDS**

Follow basic safety precautions, including:

This appliance can be used by children aged from 8 years and above and persons with reduced physical, sensory or mental capabilities or lack of experience and knowledge if they have been given supervision or instruction concerning use of the appliance in a safe way and understand the hazards involved. Children shall not play with the appliance. Cleaning and user maintenance shall not be made by children unless they are older than 8 and supervised.

Keep the appliance and cable out of reach of children under 8.

Don't connect the appliance via a timer or remote control system.

→ The surfaces of the appliance will get hot during use.

If the cable is damaged, it must be replaced by the manufacturer, its service agent, or someone similarly qualified, to avoid hazard.

- b Don't put the grill in liquid, don't use it in a bathroom, near water, or outdoors.
- Don't use the appliance near or below combustible materials (e.g. curtains).
- Don't wrap food in plastic film, polythene bags, or metal foil. This will damage your grill and you may cause a fire hazard.
- Cook meat, poultry, and derivatives (mince, burgers, etc.) till the juices run clear. Cook fish till the flesh is opaque throughout.
- Don't use your grill for any purpose other than cooking food.
- Don't use your grill if it is damaged or malfunctions.

## **HOUSEHOLD USE ONLY**

### **DIAGRAMS**

- |                                |                              |
|--------------------------------|------------------------------|
| 1. Power light (red)           | 5. Griddle light (green)     |
| 2. Grill light (green)         | 6. Drip tray                 |
| 3. Griddle                     | 7. Grill plates              |
| 4. Griddle temperature control | 8. Grill temperature control |

### **BEFORE USING FOR THE FIRST TIME**

Wipe the grill plates with a damp cloth.

### **INTRODUCTION**

The grill and griddle are independent. You may use each one on its own, or both of them together. Each has its own temperature control and light.

Each temperature control is marked **0** (off) to **3** (max).

The griddle/grill lights will come on when the selected temperature is reached then cycle on and off as the temperature is maintained.

### **PREPARATION**

1. Slide the drip tray between the two runners underneath the front of your grill (FIG A). Slide the tray all the way in. The drip tray will collect any fat or juices that run off the plates during cooking.
2. Set the grill control and the griddle control to **0**.
3. Put the plug into the power socket.

## USING THE GRIDDLE

Use the griddle to fry anything that might be flattened in the grill.

The griddle cooks on one side only, so it's slower than the grill, and you'll have to turn the food if you want to cook it on both sides.

1. Turn the griddle control to the setting you want. The power light will come on.
2. When the griddle light comes on lay the food on the griddle with a spatula or tongs, not fingers.
3. Check it's cooked. If you're in doubt, cook it a bit more.
4. When you have finished cooking, set the temperature control to **0** and unplug the appliance.

## USING THE GRILL

The hinge is articulated to cope with thick or oddly shaped foods.

The grill plates should be roughly parallel, to avoid uneven cooking.

1. Turn the grill control to the setting you want. The power light will come on.
  2. When the grill light comes on use an oven glove to open the grill.
  3. Lay the food on the bottom grill plate with a spatula or tongs, not fingers.
  4. Close the grill.
  5. Check it's cooked. If you're in doubt, cook it a bit more.
  6. When you have finished cooking, set the temperature control to **0** and unplug the appliance.
- Empty the drip tray as required into a heatproof bowl. Wipe it with kitchen paper then replace.

## CARE AND MAINTENANCE

1. Unplug the appliance and let it cool down before cleaning or storing away.
2. Wipe all surfaces with a clean damp cloth.
3. Use a paper towel moistened with a little cooking oil to remove stubborn stains.
4. Wash the drip tray in warm soapy water, or in the top rack of the dishwasher. Don't use scourers, wire wool, or soap pads.

At the places where the top and bottom plates make contact, the non-stick surfaces may show signs of wear. This is purely cosmetic, and will not affect the operation of the grill.

## COOKING TIMES AND FOOD SAFETY

Use these times purely as a guide. They're for fresh or fully defrosted food. When cooking frozen foods, add 2-3 minutes for seafood, and 3-6 minutes for meat and poultry, depending on the thickness and density of the food.

When cooking pre-packed foods, follow any guidelines on the package or label.

<b>BEEF</b>	<b>MIN</b>	<b>SANDWICHES</b>	<b>MIN</b>
fillet	5-7	cheese	2-3
loin steak	7-8	ham (cooked)	5-6
burger, 50g	5-6	roast beef (cooked)	6-7
burger, 100g	7-8	sausage (cooked)	6-7
kebabs, 25mm cube	7-8	turkey (cooked)	6-7
round steak	5-7	<b>SNACKS</b>	
sausages (thin)	5-6	hot dogs	2-3
sausages (thick)	7-8	quesadillas	2-3
sirloin	7-9	tacos, meat filling	6-8
T-Bone	8-9	<b>CHICKEN/TURKEY</b>	
<b>LAMB</b>		chicken breast pieces	5-7

kebabs, 25mm cube	7-8
minced	6-7
loin chops	4-6
<b>SEAFOOD</b>	
halibut steak, 12-25mm	6-8
kebabs, 25mm cube	4-6
prawn	1-2
red snapper fillet	3-5
salmon fillet	3-4
salmon steak, 12-25mm	6-8
scallops	4-6
sea bass fillet	3-5
swordfish steak, 12-25mm	6-9
tuna steak, 12-25mm	6-8
<b>PORK</b>	
chops, 12mm	5-6
gammon steak	5-6
kebabs, 25mm cube	7-8
minced	7-8
sausages (thin)	5-6
sausages (thick)	7-8
tenderloin, 12mm	4-6

burger, 50g, fresh/frozen	4/5
burger, 100g, fresh/frozen	5/6
kebabs, 25mm cube	7-8
thighs (chicken)	5-7
minced	7-8
turkey breast, thin sliced	3-4
<b>VEGETABLES</b>	
asparagus	3-4
carrots, sliced	5-7
aubergine, slice/cube	8-9
onions, thin slice	5-6
peppers, thin slice	6-8
peppers, grill then skin	2-3
whole peppers brushed with oil	8
potatoes, slice/cube	7-9
squash, slice/cube	6-8
<b>FRUIT</b>	
apple, halve/slice	6-8
bananas, slice lengthwise	3-4
nectarines, halve/slice	3-5
peaches, halve/slice	3-5
pineapple, slice	3-7

## A SELECTION OF RECIPES

- Preheat the grill or griddle to the maximum setting (3) before cooking.
- When times are shown as a range (e.g. 5-7 minutes), we suggest you cook for the minimum time, then start checking the food for readiness.

### CHICKEN FILLETS WITH A THAI CURRY SAUCE serves 4

- 4 large chicken fillets, trim fat and skin
- 375g Thai curry sauce
- ½ cup coconut milk
- 2 spring onions, finely chopped
- ½ handful torn coriander leaves
- steamed jasmine rice or noodles
- grated lemon or lime zest
- ½ handful torn coriander leaves



Flatten the chicken fillets to an even thickness. Preheat the grill. Lightly spray the grill plates with cooking oil. Grill the chicken fillets till cooked (5-7 minutes). Meantime, heat the sauce in a pan, stir in the coconut milk, spring onions and coriander leaves. Stir till cooked (don't let it boil). Put a portion of sauce on a plate, lay a chicken fillet on the sauce, then put a little more sauce on top. Mix the zest with the rice/noodles and torn coriander leaves, and serve with crisp green vegetables.

## **CHICKEN TANDOORI WITH YOGURT MARINADE serves 4**

- 2 boneless, skinless chicken breasts
- 200-250g carton plain low-fat yogurt
- 1 tbsp lemon juice
- 2 tsp paprika
- 2 garlic cloves, minced
- ½ tsp ground ginger
- ½ tsp cumin
- ½ tsp cayenne pepper
- ½ tsp cinnamon



Use a lidded casserole dish big enough to hold everything. Mix the yogurt, lemon juice, paprika, garlic, ginger, cumin, cayenne and cinnamon in the dish. Cut each chicken breast into two, add them to the dish, and turn till they're well coated. Cover and refrigerate for 1-8 hours, turning at least every hour. Grill the chicken till it's cooked through (5-7 minutes). Discard the marinade.

## **WHOLEGRAIN PANINI WITH FETA, RED ONIONS AND RED PEPPER serves 1**

- 2 thick slices wholegrain or wholewheat bread
- 50g reduced fat feta cheese
- ½ red onion, cut into thin strips
- ½ red pepper, cut into strips
- 2 tbsp balsamic vinegar
- ½ tsp fresh ground black pepper



Mix the onion, red pepper, balsamic vinegar and black pepper in a bowl. Spoon the mixture on to the grill, cook till softened (1-2 minutes), and lay it on a slice of bread. Tear the feta, sprinkle over the mixture, and top with the other slice of bread. Clean the grill, then grill the panini for 2-3 minutes. Serve with a watercress and tomato salad.

## **THE ORIGINAL BURGER serves 4**

- 500g lean minced beef
- 1 tbsp Worcestershire sauce
- 1 tsp black pepper
- 1 red onion
- 4 wholegrain burger buns
- tomato, lettuce, dill pickles, etc. to garnish



Combine the mince, Worcestershire sauce and pepper, and shape into 4 burgers. Slice the onion into 12mm/½" thick slices. Grill the burgers for 4 minutes, top each with an onion slice, then grill for 3-4 minutes more. Serve the burgers on the buns with your choice of garnish (tomato, lettuce, dill pickles, etc.).

## **QUICK AND EASY GRILLED BANANAS serves 2**

- 2 bananas, peeled
- 2 tbsp walnuts, finely chopped
- 2 tbsp sugar
- ½ tsp cinnamon



Mix the walnuts, sugar and cinnamon in a bowl. Split the bananas lengthwise, then across their width. Lay the bananas on the grill, flat sides uppermost, and spoon the mixture on top of them. Grill till the bananas are warm and the cinnamon and walnuts are slightly glazed (3-4 minutes).

## **HERBED CHICKEN AND MUSHROOM KEBABS serves 4**

- 2 boneless, skinless chicken breasts
- 500g fresh whole mushrooms
- 1 tsp dried rosemary
- 1 tbsp dried parsley
- ½ tsp dried thyme
- ¼ cup lemon juice
- 2 tbsp white vinegar
- ½ cup nonfat chicken broth
- 1 tsp black pepper
- 8 wooden skewers, soak in water, pat dry



Use a lidded casserole dish big enough to hold the chicken, mushrooms and marinade. Mix the rosemary, parsley, thyme, juice, vinegar, broth, salt and pepper in the dish. Cut the chicken into 25mm/1" cubes, add to the dish, and turn till they're well coated. Add the mushrooms, and turn gently. Cover and refrigerate for 4-12 hours, turning occasionally. Thread the chicken and mushrooms on the skewers, and grill till cooked through (5-7 minutes). Discard the marinade.

## **MEDITERRANEAN BEEF AND VEGETABLE GRILL serves 4**

- 500g hindquarter flank steak
- 1 small courgette, cut into 8 pieces
- 1 small tomato, cut into 8 pieces
- 1 small onion, cut into 8 pieces
- 1 green pepper, cut into 8 pieces
- 1 tbsp balsamic vinegar
- 1 tsp fresh ground black pepper
- 1 tsp garlic granules
- 8 wooden skewers, soak in water, pat dry



Mix the vinegar, pepper and garlic granules in a bowl. Freeze the steak for 30 minutes, then cut it into thin strips, across the grain. Discard any fat. Thread the steak on 4 skewers, and the tomato and vegetables on the other 4. Grill the steak skewers for 4 minutes, then add the vegetable skewers to the grill. Sprinkle the skewers with the vinegar, pepper and garlic mixture, and grill for 3-4 minutes more.

## CREAMY CHEESY CHICKEN PARCELS WITH HIDDEN GREEN STUFF serves 2

- 1 lean skinless chicken breast
- 2 flour tortilla wraps
- 75-100g reduced fat cream cheese
- 100g fresh baby spinach leaves
- 1 tsp mustard powder
- 1 tsp grated nutmeg
- 1 tsp pepper



Grill the chicken till it's cooked through (6-8 minutes).

Remove it from the grill, let it cool, and cut it into strips.

Wash and dry the spinach, wilt the leaves on the grill for 20-30 seconds, remove, and dry with kitchen paper.

Mix the cream cheese and spinach in a bowl, then fold in the chicken strips.

Spoon the mixture into the centre of the tortilla wraps, fold one end of each wrap over, roll the wraps up, and warm the filled wraps on the grill for 2-3 minutes.

## HEALTHY PIZZA PITTA POCKETS serves 2

- 2 slices lean ham or turkey (cooked)
- 50g reduced fat mozzarella
- 2 wholemeal pitta breads
- 2 tomatoes, thinly sliced
- 2 mushrooms, thinly sliced
- ¼ small onion, thinly sliced
- 1 tbsp sweetcorn
- ¼ green pepper, diced
- 1 tbsp tomato purée
- 1 tsp olive oil
- 1 tsp dried mixed herbs



Slit open each pitta bread to form pockets, and spread the tomato purée inside each pocket.

Cut the ham/turkey into strips, turn them in a bowl with the other ingredients, rest for half an hour to rehydrate the herbs, then fill the pitta pockets and grill for 3-5 minutes.

## SMOKED MACKEREL PANINI WITH TOMATOES AND CRÈME FRAICHE serves 1

- 2 small cooked smoked mackerel fillets
- 2 thick slices wholegrain/wholewheat
- 4 cherry tomatoes, halved
- 1 large handful watercress

### *Dressing*

- 2 tbsp reduced fat crème fraiche
- ½ tsp lemon zest, grated
- squeeze lemon juice
- 1 tsp black pepper



Mix the dressing ingredients and refrigerate.

Flake the mackerel on a slice of bread, top with tomatoes and watercress, then the other slice, cook for 2-3 minutes, add the dressing, and serve.

## WARM ASIAN-STYLE NOODLE AND TOFU SALAD serves 2

- 60g buckwheat or soba noodles
- 250g pre-cooked tofu, drain and cube
- 1 carrot, peeled and grated into strips
- 1 head pak choi, shredded
- ½ courgette, cut into long strips
- ½ red onion, cut into strips
- small handful fresh coriander leaves, torn



- Marinade*
- 1 garlic clove, crushed
  - 1 red chilli, de-seeded, finely chopped
  - 2 tbsp reduced sodium soy sauce
  - 1 tsp sweet chilli dipping sauce
  - 1 tsp sesame oil
  - juice of ½ lime

Remove the sausage skins. Mix the sausagemeat, marjoram, thyme, parsley, and pepper in a bowl. Cut each tenderloin in two, then cut a slit sideways into each piece to make a pocket. Stuff the pockets with the mixture, and fasten the edges with cocktail sticks. Grill till the pork and stuffing are cooked through (6-8 minutes).

## SANTA FÉ VEGGIE-BURGER serves 4

- 1 cup steamed white rice
- ½ cup of canned corn kernels
- 1 green pepper, seeded
- 1 large white onion
- 1 tsp fresh ground black pepper
- 1 tsp lemon juice
- 1 tsp chilli powder
- 4 wholegrain hamburger buns
- non-fat cooking spray



Use a blender or food processor to process the rice, corn, green pepper, onion, pepper, juice and chilli powder to a coarse, mealy texture. Shape the mixture into 4 burgers and refrigerate for 2 hours. Spray the grill lightly with non-fat cooking spray, grill the burgers till well browned (6-7 minutes), then serve in the buns.

## GRILLED STRAWBERRY MAPLE SHORTCAKE serves 4

- 1 low-fat shortcake, cut into 8 slices
- ¼ cup maple syrup
- 2 cups fresh strawberries, sliced
- 1 cup non-fat whipped cream topping



Lay the shortcake pieces on the grill, brush with maple syrup, and grill for 3-5 minutes. Remove, top with strawberry slices and whipped cream topping.

## **GOUJONS OF FISH WITH CARROT STICKS AND SWEET POTATO WEDGES serves 2**

- 1 large tuna, cod or salmon steak
- 1 medium carrot
- 1 small sweet potato
- 25g wholemeal flour
- 1 egg white
- breadcrumbs (1 slice of wholemeal bread)
- 1 tsp white pepper
- ½ tsp medium curry powder (optional)
- 1 tsp clear honey
- 1 tsp olive oil
- 1 tsp paprika



Put the olive oil in a bowl. Cut the sweet potato into thin wedges then toss them in the olive oil. Put them on a plate. Stir the paprika and honey into the bowl. Cut the carrot into sticks about the same width as the thick ends of the potato wedges, and toss them in the bowl to coat them. Put the wedges and sticks on the grill, and cook for 4 minutes.

Mix the flour, curry powder and pepper on a plate. Put the egg white on another plate, and mix with a fork. Put the breadcrumbs on a third plate.

Cut the fish into goujons (fingers). Dip them into the seasoned flour, then into the egg white, then the breadcrumbs. When the wedges and sticks have cooked for 4 minutes, add the goujons to the grill, and cook for another 3-4 minutes, or till the breadcrumbs turn golden.

## **FILLET STEAK WITH TOMATO CONCASSE serves 6**

- 6 fillet steaks
- 1 clove garlic

### *Tomato concasse*

- 2 large onions, finely chopped
- 2 tbsp olive oil
- 450g tin of tomatoes, drained and chopped
- 1 bay leaf
- ¼ tsp thyme
- grated zest of ½ orange
- pinch of saffron (optional)
- 1 large clove garlic, crushed
- salt and pepper



Sauté the onions in a pan till they're just translucent. Add the tomatoes, then the other concasse ingredients, and simmer, stirring occasionally, till the concasse is thick and rich. Preheat the grill. Trim the fillets, then flatten gently. Cut the garlic clove in half, and rub the cut side over the surfaces of the fillets. Lay the fillets on the grill, and cook for 2-5 minutes, depending on how rare you want them. Remember – it's fillet steak – it doesn't take a lot of cooking! Put a portion of concasse on a plate, lay a steak on top, then pour a little more concasse over it. Serve with creamy mashed potatoes, boiled baby new potatoes in butter, carrot sticks and a green vegetable.

## **SAUSAGE AND HERB STUFFED PORK serves 4**

- 250g/½lb low-fat sausage, uncooked
- ½ cup fresh breadcrumbs
- 2 tbsp fresh parsley
- ½ tsp thyme
- ½ tsp marjoram
- 1 tsp fresh ground black pepper
- 2 whole pork tenderloins (fillets)
- 8 cocktail sticks, soak in water, pat dry



Remove the sausage skins. Mix the sausagemeat, marjoram, thyme, parsley, and pepper in a bowl. Cut each tenderloin in two, then cut a slit sideways into each piece to make a pocket. Stuff the pockets with the mixture, and fasten the edges with cocktail sticks. Grill till the pork and stuffing are cooked through (6-8 minutes).

## **TEX-MEX BURGER serves 4**

- 450 g lean minced beef
- 2 tbsp barbecue sauce
- 1 strong onion, finely chopped
- 1 tbsp fresh salsa
- 1 tsp chilli powder

Combine everything, shape into 4 burgers, grill for 4 minutes, then check for readiness.

## **CHEESE AND HORSERADISH BURGER serves 4**

- 450 g lean minced beef
- 125 g low fat Cheddar cheese, grated
- 2 tbsp creamed horseradish sauce
- ½ tsp garlic powder
- ½ tsp black pepper

Combine everything, shape into 4 burgers, grill for 4 minutes, then check for readiness.

## **RANCHERO BURGERS serves 4**

- 375 g lean minced beef
- 125 g tinned kidney beans, drain and mash
- 2 cloves garlic, finely chopped
- 4 tbsp barbecue sauce
- ½ tsp black pepper
- ½ tsp sea salt

Combine everything, shape into 4 burgers, grill for 4 minutes, then check for readiness.

## **GEORGE FOREMAN'S POWERBURGER serves 4**

- 375 g lean minced beef
- 4 tbsp seasoned breadcrumbs
- 4 tbsp chopped vegetables – onions, spring onions, courgettes, parsley (these can be sautéed)

Combine the vegetables and breadcrumbs in a bowl. Add the minced beef and mix well. Shape the mixture into 4 10cm wide burgers. Preheat the grill and cook for 5-6 minutes, or till the meat is no longer pink and the juices run clear, turning once. This recipe is from The healthy Gourmet (Clarkson Potter) by Cherie Calbom.

# W ENVIRONMENTAL PROTECTION

To avoid environmental and health problems due to hazardous substances in electrical and electronic goods, appliances marked with this symbol mustn't be disposed of with unsorted municipal waste, but recovered, reused, or recycled.

## **SERVICE**

If you ring Customer Service, please have the **Model No.** to hand, as we won't be able to help you without it. It's on the rating plate (usually underneath the product).

The product isn't user-serviceable. If it's not working, read the instructions, check the plug fuse and main fuse/circuit breaker. If it's still not working, consult your retailer.

If that doesn't solve the problem – ring Customer Service – they may be able to offer technical advice.

If they advise you to return the product to us, pack it carefully, include a note with your name, address, day phone number, and what's wrong. If under guarantee, say where and when purchased, and include proof of purchase (till receipt). Send it to:

Customer Service

Spectrum Brands (UK) Ltd

Fir Street, Failsworth, Manchester M35 0HS

email: [support@georgeforeman.co.uk](mailto:support@georgeforeman.co.uk)

telephone: 0845 230 0598 (local rate number)

## **GUARANTEE**

Defects affecting product functionality appearing within two years of first retail purchase will be corrected by replacement or repair provided the product is used and maintained in accordance with the instructions. Your statutory rights are not affected. Documentation, packaging, and product specifications may change without notice.