

Instant™

VORTEX PLUS™

6 QUART AIR FRYER



User manual

Important safeguards

Product, parts and accessories

Get started

Control panel

Cooking

Care, cleaning and storage

Troubleshooting

Warranty

Contact

Download the Instant Pot app with
1000+ recipes at instantappliances.com/app.

IMPORTANT SAFEGUARDS



(Yes, we have to)

At Instant Brands™ your safety always comes first. The Instant™ Vortex™ family was designed with your safety in mind, and we mean business. Visit **instantappliances.com** to learn about this appliance's safety mechanisms.

When using electrical appliances, basic safety precautions should always be followed:

- 01** READ ALL INSTRUCTIONS, SAFEGUARDS, AND WARNINGS BEFORE OPERATING THE APPLIANCE. FAILURE TO FOLLOW THESE SAFEGUARDS AND INSTRUCTIONS MAY RESULT IN INJURY AND/OR PROPERTY DAMAGE.
- 02** The appliance's outer surfaces may become hot during use. DO NOT touch hot surfaces. Only use the air fryer basket handle to lift and carry the air fryer basket. Wear proper hand protection when handling hot components. Extreme caution must be used when moving the appliance. Let the appliance cool to room temperature before handling or moving.
- 03** **⚠ CAUTION** To protect against the risk of electrical shock, DO NOT immerse power cord, plug, or the appliance in water or other liquid.
- 04** DO NOT rinse the appliance under tap.
- 05** The cooking chamber contains electrical components. To avoid electrical shock, DO NOT put liquid of any kind into the cooking chamber.
- 06** This appliance is NOT to be used by children or by persons with reduced physical, sensory, or mental capabilities. Close supervision is necessary when this appliance is used near children and these individuals. Children should not use or play with this appliance.
- 07** Turn off and unplug when not in use, as well as before adding or removing parts or accessories, and before cleaning. To turn off, press **Cancel**. To unplug, grasp the plug and pull from the outlet. NEVER pull from the power cord.
- 08** Avoid making contact with moving parts.
- 09** Inspect the appliance and power cord regularly. DO NOT operate any appliance with a damaged cord or plug or after the appliance malfunctions, or is dropped or damaged in any manner. For assistance, contact the Customer Care Team at **support@instantappliances.com** or **1-800-828-7280**.

⚠ WARNING

Read this manual carefully and completely and retain for future reference. Failure to adhere to safety instructions may result in serious injury or damage.

IMPORTANT SAFEGUARDS



- 10 DO NOT use any accessories or attachments not authorized by Instant Brands Inc. The use of attachments not recommended by the manufacturer, may cause a risk of injury, fire or electric shock.
- 11 For household countertop use only. DO NOT use outdoors. Not for commercial use.
- 12 DO NOT place the appliance on any kind of stovetop, or in a heated oven; heat from an external source will damage the appliance.
- 13 DO NOT let power cord contact hot surfaces or open flame, including a stovetop.
- 14 DO NOT use appliance for anything other than intended use.
- 15 Proper maintenance is recommended after each use. Refer to **Care, cleaning and storage**. Let the appliance cool to room temperature before cleaning or storage.
- 16 **⚠ CAUTION** Spilled food can cause serious burns. A short power-supply cord is provided to reduce the hazards resulting from grabbing, entanglement and tripping. Keep appliance and cord away from children. NEVER drape cord over edge of table or counter, NEVER use power outlet below counter, and NEVER use with an extension cord.
- 17 DO NOT attempt to repair, replace, alter, or modify components of the appliance. This may cause electric shock, fire and/or injury, and will void the warranty.
- 18 DO NOT tamper with any of the safety mechanisms.
- 19 DO NOT use the appliance in electrical systems other than 120 V ~ 60 Hz. DO NOT use with power converters or adapters.
- 20 DO NOT overfill the appliance or accessories. Overfilling may cause food to contact the heating element, which may result in fire and/or personal injury.
- 21 DO NOT cover the cooling vents while the appliance is in operation. Doing so will prevent even cooking and may cause damage to the appliance.
- 22 NEVER pour oil into the cooking chamber. This could result in fire and/or personal injury.

⚠ WARNING

Read this manual carefully and completely and retain for future reference. Failure to adhere to safety instructions may result in serious injury or damage.

IMPORTANT SAFEGUARDS



- 23 While cooking, the internal temperature of the appliance reaches several hundred degrees. To avoid personal injury, NEVER place unprotected hands inside the appliance until it has cooled to room temperature.
- 24 When cooking, DO NOT place the appliance against a wall or against other appliances. Leave at least 5" / 13 cm of free space on the back, sides, and above the appliance. DO NOT operate the appliance on or near combustible materials such as tablecloths and curtains. DO NOT place anything on top of the appliance.
- 25 When in operation, hot air is released through the cooling vents. Keep your hands and face at a safe distance from the cooling vents and take extreme caution when removing the accessories from the appliance.
- 26 Should the unit emit black smoke, press **Cancel** and unplug the appliance immediately. Wait for smoking to stop before opening the door, then clean the appliance thoroughly.
- 27 DO NOT leave the appliance unattended while in use.
- 28 NEVER connect this appliance to an external timer switch or separate remote-control system.
- 29 Use extreme caution when removing hot accessories from the cooking chamber or disposing of hot grease.
- 30 Oversized foods and/or metal utensils must not be inserted into the cooking chamber as they may cause risk of fire and/or personal injury.
- 31 DO NOT store any materials, other than the included accessories, in the cooking chamber when not in use.
- 32 DO NOT place any combustible materials in the cooking chamber, such as paper, cardboard, plastic, Styrofoam or wood.
- 33 DO NOT use appliance accessories in any other appliance including microwave ovens, toaster ovens, convection or conventional ovens, ceramic, electric, induction or gas cooktops, or outdoor grills.
- 34 **⚠ CAUTION** Use extreme caution when moving an appliance containing hot oil or other hot liquids.

SAVE THESE INSTRUCTIONS.

⚠ WARNING

Read this manual carefully and completely and retain for future reference. Failure to adhere to safety instructions may result in serious injury or damage.

IMPORTANT SAFEGUARDS



⚠ WARNING

To avoid injury, read and understand the instructions in this user manual before attempting to use this appliance.

⚠ WARNING

Electrical shock hazard. Use grounded outlet only.

- DO NOT remove ground.
- DO NOT use an adapter.
- DO NOT use an extension cord.

Failure to follow these instructions may result in electric shock and/or serious injury.

⚠ WARNING







THE FAILURE TO FOLLOW ANY OF THE IMPORTANT SAFEGUARDS AND/OR THE INSTRUCTIONS FOR SAFE USE IS A MISUSE OF YOUR APPLIANCE THAT CAN VOID YOUR WARRANTY AND CREATE THE RISK OF SERIOUS INJURY.

Special cord set instructions

As per safety requirements, a short power supply cord (0.6 m to 0.9 m / 24" to 35") is provided to reduce the hazards resulting from grabbing, entanglement and tripping.

This appliance has a 3-prong grounding plug. To reduce the risk of electric shock, plug the power cord into a grounded (earthed) electrical outlet that is easily accessible.

Product specifications

					
Vortex Plus 6	1700 W	120 V ~ 60 Hz	6 Quart	12.46 lb 5.65 kg	in: 14.92W x 12.36D x 12.83H cm: 37.9W x 31.4D x 32.6H

Find your model name and serial number

Find both of these on the rating label on the back of the air fryer, near the power cord.

⚠ WARNING

Read this manual carefully and completely and retain for future reference. Failure to adhere to safety instructions may result in serious injury or damage.

Table of contents

IMPORTANT SAFEGUARDS	2
Special cord set instructions.....	5
Product specifications	5
Find your model name and serial number	5
Product, parts and accessories	7
Get started.....	8
Initial set up.....	8
Initial test run	9
Control Panel.....	10
Settings.....	11
Cooking status.....	12
Status messages.....	12
Cooking	13
Air Fry, Roast, Broil and Bake	13
Cooking tips	15
Reheat and Dehydrate	16
Care, cleaning and storage	17
Troubleshooting.....	18
Warranty.....	19
Contact.....	21

Product, parts and accessories

Before using your cute new air fryer, make sure that everything is present and accounted for.

Air fryer

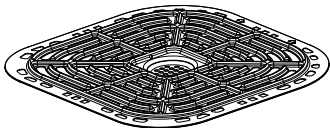
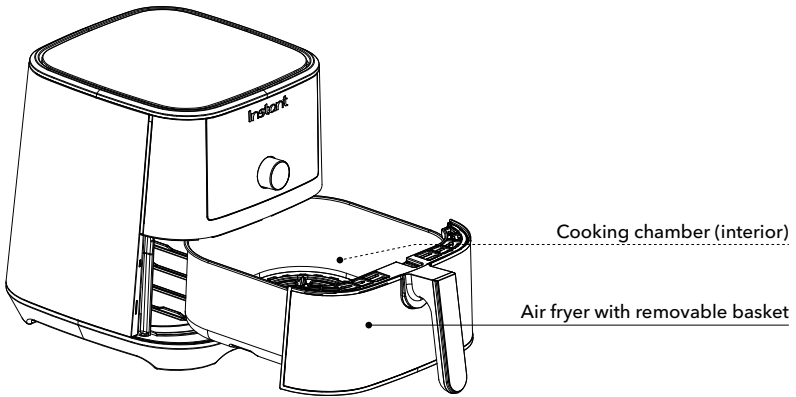
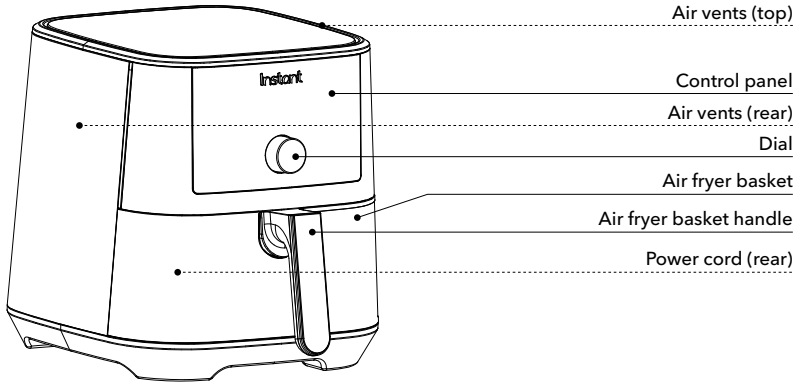

Cooking tray

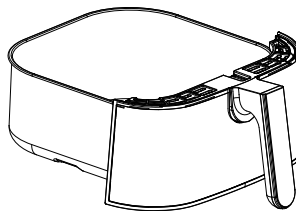



Air fryer basket

*Illustrations in this document are for reference only and may differ from the actual product.
Always refer to the actual product.*

Get started

Initial set up

 *"Notice the small things. The rewards are inversely proportional." - Liz Vassey*

- 01** Pull that Vortex Plus out of the box!
- 02** Remove the air fryer basket and check the cooking chamber for loose packing material before first use.
- 03** You may be tempted to put the air fryer on your stovetop – *but don't do it!* Place it on a stable, level surface, *away* from combustible material and external heat sources. Do not place your air fryer on top of another appliance.
 Make sure to leave *at least* 13 cm / 5" of space above and around all sides of the appliance.
- 04** Follow the **Care, cleaning and storage** instructions to wash your new air fryer before using it.
 Don't remove the safety warning stickers or the rating label from the air fryer.

Is something missing or damaged?

Get in touch with a Customer Care Advisor through our chat widget at instantappliances.com/#chat, by email at support@instantappliances.com or by phone at **1-800-828-7280** and we'll happily make some magic happen for you!

WARNING



<p>Read the Important Safeguards before using the appliance. Failure to read and follow those instructions for safe use may result in damage to the appliance, property damage or personal injury.</p>	<p>Do not place the appliance on a stovetop, on another appliance, or in a heated oven. Heat from an external source will damage the appliance.</p>	<p>To avoid the risk of fire, property damage, and/or personal injury, do not place anything on top of the appliance, and do not block the air vents.</p>
---------------------------------------------------------------------------------------------------------------------------------------------------------------------------------------------------------------	-----------------------------------------------------------------------------------------------------------------------------------------------------	-----------------------------------------------------------------------------------------------------------------------------------------------------------

Get started



Initial test run

Do you *have* to do the test run? No – but getting to know the ins and outs of your Vortex Plus prepares you for success in the kitchen! Take a few minutes to get to know how this little guy works.

Stage 1: Setting up the air fryer for cooking

- 01** Connect the power cord to a 120 V power source.
The air fryer is in standby mode and the display shows **OFF**.
- 02** Remove the air fryer basket from the cooking chamber.
- 03** Place the cooking tray on the bottom of the air fryer basket (if it is not already installed).
-  Make sure the little indicator arrows on the cooking tray point towards the back or the front of the air fryer basket.
- 04** Insert the air fryer basket back into the cooking chamber.
- 05** Touch **Air Fry**.
- 06** Touch **Temp**, then turn the dial to adjust the cooking temperature to 205°C / 400°F.
-  Each Smart Program automatically saves the adjustments you make to the time and temperature when you touch **Start**.
- 07** Touch **Start** to begin!
The display shows **On** and the cooking status shows **Preheat**.
-  The first few times you use your air fryer, you may notice a strong plastic smell. This is normal, non-toxic, and goes away quickly.

Stage 2: "Cooking" (...but not really, this is just a test!)

- 01** When the air fryer is hot enough, the display shows **Add Food**.
-  For this initial test, do not add food to the air fryer basket.
Carefully remove and re-insert the air fryer basket. The display shows the cooking time and temperature, and the cooking status shows **Cook**.
- 02** Part way through cooking, the display shows **turn Food**.
Wait 10 seconds for the program to resume automatically, or, remove and re-insert the air fryer basket to pause and resume the program manually.
- 03** When 1 minute remains, the display counts down the remaining cooking time in seconds.
When the Smart Program completes, the display shows **End** and the fan blows for a little while to help cool the air fryer.
- 04** Touch **Cancel** to return to standby mode and start cooking for real!
-  If you forget this last step, the air fryer will beep to remind you about it after 5, 30, and 60 minutes.

CAUTION

The air fryer and air fryer basket will be hot during and after cooking. To avoid the risk of burn injury, DO NOT touch hot surfaces. Allow the air fryer to cool to room temperature, then clean the appliance according to **Care, cleaning and storage** instructions.

Control panel

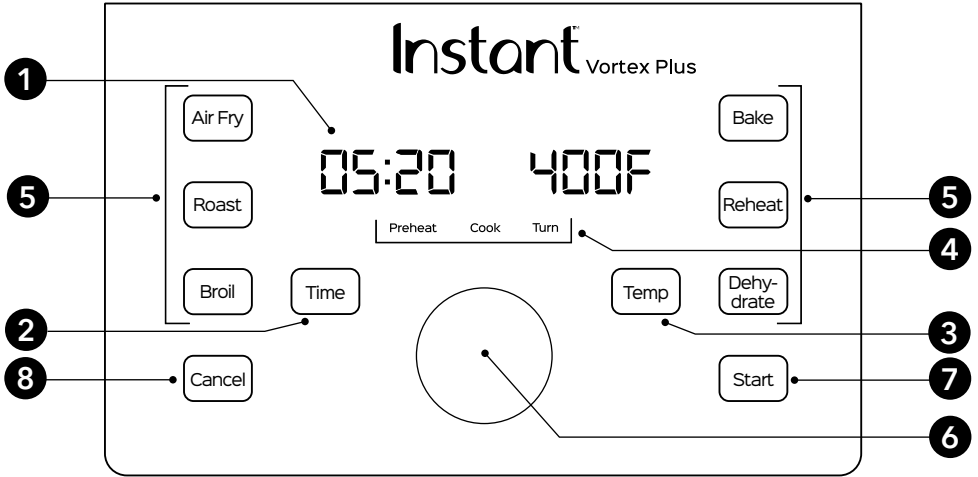

1	Time/temperature display	Shows the cooking time, the set temperature, reminder messages and error messages.
2	Time	Touch Time if you want to adjust the cooking time.
3	Temp	Touch Temp if you want to adjust the cooking temperature.
4	Cooking status	Preheat, Cook and Turn.
5	Smart programs	<ul style="list-style-type: none"> • Air Fry • Roast • Broil • Bake • Reheat • Dehydrate
6	Dial	Rotate to adjust cooking times and temperatures. Press to wake the display.
7	Start	Touch Start to begin a selected smart program.
8	Cancel	Touch Cancel to stop a smart program at any time and go back to standby.

*Illustrations in this document are for reference only and may differ from the actual product.
Always refer to the actual product.*

Settings

To do this...	Do this!
Wake the air fryer.	Touch any button, press the dial, or remove and re-insert the air fryer basket to wake the air fryer. The display shows OFF to let you know that it's in standby mode and ready for action.
Turn sounds on and off.	In standby mode, touch and hold both Time and Temp for 5 seconds.  Error alerts cannot be silenced.
Change temperature scale (°C or °F).	In standby mode, touch and hold the Temp key for 5 seconds to toggle between °C and °F .
Save a custom cooking time.	Select a smart program, then touch Time , and use the dial to adjust the time as you like. Touch Start to save the change to memory.
Save a custom cooking temperature.	Select a smart program, then touch Temp and turn the dial to adjust the temperature as you like. Touch Start to save the change to memory.
Reset an individual smart program.	In standby mode, touch and hold the smart program key you want to reset (for example: Air Fry) for 5 seconds. The cooking time and temperature for that Smart Program are restored to the factory default settings.
Reset all smart programs.	In standby mode, press and hold the dial for 5 seconds. The cooking times and temperatures for all Smart Programs are restored to the factory default settings.

Cooking status

00:15 400F

Preheat

Cook

Turn

The air fryer is heating up to the perfect temperature to cook your meal.



 Not applicable to Reheat or Dehydrate.

Cooking is in progress.

Food is ready to be flipped or tossed, as required by your recipe.

 Only applicable to Air Fry and Roast.

Status messages

OFF	The air fryer is in standby mode.
On	A smart program is in the Preheat stage.  Not applicable to Reheat or Dehydrate.
Add Food	This message appears to let you know that the air fryer has reached the perfect cooking temperature and food can be added to the air fryer basket (if it hasn't been already).  Not applicable to Reheat or Dehydrate.
00:15	The display shows the cooking time and on-screen messages.
400F	The display also shows the set cooking temperature and on-screen messages.
Turn Food	Food is ready to be turned or tossed, as recommended by your recipe.  Only applicable to Air Fry and Roast.
End	The Smart Program has finished.

Cooking

Cooking in the Vortex Plus is quick and easy – food goes in, crispy deliciousness comes out!

Check out the **cooking timetables** for guidance, or visit our **recipe site** for fun, easy-to-follow recipes with big crunch. You can also download the free **Instant Pot app** to search recipes, save favorites, make notes and more!

⚠ CAUTION

When cooking meat, always use a meat thermometer to ensure the internal temperature reaches a safe minimum temperature. Refer to the USDA's **Safe Minimum Internal Temperature Chart** or Health Canada's **Cooking Temperatures Chart** for more information.

Air Fry, Roast, Broil and Bake

These programs give your meals all the rich, crispy flavor of deep frying with little to no oil, so you can say, "See ya!" to the greasy mess and extra calories! The presets are a starting point that you can experiment with to get the results you like best.

Smart program	Default time	Time range	Default temperature	Temperature range
Air Fry	15 minutes (00:15)	1 minute to 1 hour (00:01 to 01:00)	196°C / 385°F	82 to 205°C 180 to 400°F
Roast	18 minutes (00:18)	1 minute to 1 hour (00:01 to 01:00)	193°C / 380°F	82 to 205°C 180 to 400°F
Broil	6 minutes (00:06)	1 to 40 minutes (00:01 to 00:40)	205°C / 400°F	Not adjustable.
Bake	30 minutes (00:30)	1 minute to 1 hour (00:01 to 01:00)	185°C / 365°F	82 to 205°C 180 to 400°F

Stage 1: Setting up for cooking

- 01 Follow steps 01 to 04 in the **Initial test run: Stage 1** to set up the air fryer.
- 02 Touch the smart program you want to use: **Air Fry, Roast, Broil** or **Bake**.
- 03 Touch **Temp**, then turn the dial to adjust the temperature.

- 04 Touch **Time**, then turn the dial to adjust the time.

 Smart Programs automatically save adjustments to temperature and time settings when you touch **Start**.

- 05 Touch **Start** to begin!
The display shows **On** and the cooking status shows **Preheat**.

Cooking

Stage 2: Cooking

01 When the display shows **Add Food**, remove the air fryer basket and carefully place your food items inside the hot cooking chamber.

 You can put food directly on the cooking tray or within any oven-safe baking dish.

02 Carefully re-insert the air fryer basket. The display shows the cooking time and temperature, and the cooking status shows **Cook**.

03 Part way through cooking, the display shows **turn Food**.

 Not applicable to Broil or Bake.

If you want to toss or turn your food, remove the air fryer basket and take care of business, then re-insert the basket into the air fryer. Cooking pauses and resumes automatically.

 If your food does not need to be flipped, wait 10 seconds for the program to resume automatically.

04 When the display shows **End**, carefully remove your food from the hot cooking chamber.

CAUTION

The air fryer oven and air frying accessories will be hot during and after cooking. Do not touch hot surfaces with unprotected hands. Allow all items to cool to room temperature, then clean them according to **Care, cleaning and storage** instructions.

Always use proper hand protection and exercise extreme caution when adding or removing food from the hot cooking chamber.

Cooking

Cooking tips

Give all your favorite fresh and frozen oven-baked and deep-fried snacks a fighting chance!

- Preheating is an important step! Wait for the **Add Food** message to appear before adding food to the air fryer basket.
- When baking muffins, buns, quiche, and other treats, cover your oven-safe baking dish to prevent the top from overcooking.
- For coated food, like onion rings or deep-fried pickles, use an egg wash with breadcrumbs rather than liquid-based batters to make sure that batter sticks to the food.
- Spray food items with cooking oil *before* adding seasoning to get the seasoning to stick well.
- For super crispy fries, soak your fresh-cut potato sticks in ice water for 15 minutes, then pat them dry and spray them lightly with oil before cooking.
- Patting dry moist food items before cooking to prevents excess steam and splatter and gives you crispier results.
- Air frying can cause oil and fat to drip from foods. To prevent excess smoke, carefully remove and drain the air fryer basket as needed.

Check out the **cooking timetables**, download the **Instant Pot app**, or visit our **recipe site** for fun, easy-to-follow recipes.

CAUTION

To avoid the risk of fire, property damage and personal injury, **DO NOT** spray cooking oil into the cooking chamber

CAUTION

When cooking meat, always use a meat thermometer to ensure the internal temperature reaches a safe minimum temperature. Refer to the USDA's **Safe Minimum Internal Temperature Chart** or Health Canada's **Cooking Temperatures Chart** for more information.

Cooking

Reheat and Dehydrate

Smart program	Default time	Time range	Default temperature	Temperature range
Reheat	10 minutes (00:10)	1 minute to 1 hour (00:01 to 01:00)	138°C / 280°F	49 to 182°C 120 to 360°F
Dehydrate	8 hours (08:00)	1 to 72 hours (01:00 to 72:00)	54°C / 130°F	35 to 79°C 95 to 175°F

- 01 Follow steps 01 to 04 in the **Initial test run: Stage 1** to set up the air fryer.
- 02 Remove the air fryer basket and place your food items inside, then carefully re-insert it.
- 03 Touch the smart program you want to use: **Reheat** or **Dehydrate**.
- 04 Touch **Temp**, then turn the dial to adjust the temperature.
- 05 Touch **Time**, then turn the dial to adjust the time.
 Smart Programs automatically save adjustments to temperature and time settings when you touch **Start**.
- 06 Touch **Start** to begin heating.
The time begins to count down right away.
- 07 When the display shows **End**, carefully remove your food from the hot cooking chamber.

CAUTION

The air fryer oven and air frying accessories will be hot during and after cooking. Do not touch hot surfaces with unprotected hands. Allow all items to cool to room temperature, then clean them according to **Care, cleaning and storage** instructions.

To avoid a burn injury, always use proper hand protection and exercise extreme caution when adding or removing food from the hot cooking chamber.

Care, cleaning and storage

Clean your air fryer and accessories after each use.

Always unplug the air fryer and let it cool to room temperature before cleaning. Never use harsh chemical detergents, scouring pads, or powders on any of the parts or components.

Let all surfaces dry thoroughly before use, and before storage.

Part or accessory	Cleaning method and notes
Air fryer basket	<ul style="list-style-type: none">• Clean the air fryer basket with a sponge or cloth and warm water and dish soap, then rinse well. Ensure that all grease and food debris are removed.• DO NOT immerse the basket in water or any other liquid.• DO NOT machine wash the basket.
Cooking tray	<ul style="list-style-type: none">• Clean the cooking tray with a cloth or sponge and warm water and dish soap.• The cooking tray has non-stick coating. To avoid damage to the non-stick coating, DO NOT use metal cleaning utensils.
Cooking chamber	<ul style="list-style-type: none">• Clean the cooking chamber with a sponge or soft cloth and warm water and dish soap.• To remove baked-on grease and food residue from cooking chamber, spray with a mixture of baking soda and vinegar and wipe clean with damp cloth.• For stubborn stains, allow the mixture to sit on the affected area for several minutes before scrubbing clean.• Check the heating coil for oil spatter and food debris. Clean the heating coil with a damp cloth as needed. Ensure the heating coil is completely dry before next use.
Exterior	<ul style="list-style-type: none">• Clean with a soft, damp cloth or sponge and wipe dry.

WARNING

To avoid risk of electrical shock and personal injury: <ul style="list-style-type: none">- Do not immerse the appliance in water.- Do not rinse the appliance under a tap.- Do not wet prongs of the power cord.	Without proper cleaning, food and grease splatter may build up around the heating element, causing the risk of smoke, fire, and personal injury.	If you see or smell smoke, touch Cancel , unplug the appliance, and allow it to cool. Remove food splatter or grease with a soft cloth and dish detergent.
--------------------------------------------------------------------------------------------------------------------------------------------------------------------------------------------------------------------------------------------------	--------------------------------------------------------------------------------------------------------------------------------------------------	-------------------------------------------------------------------------------------------------------------------------------------------------------------------

Troubleshooting

Register your air fryer today!

If your problem persists or if you have questions, get in touch with a Customer Care Advisor through our chat widget at instantappliances.com/#chat, by email at support@instantappliances.com or by phone at 1-800-828-7280.

Problem	Possible reason	Solution
Black smoke is coming from the air fryer.	⚠ CAUTION Stop cooking immediately. Cancel the Smart Program, then unplug the air fryer and allow it to cool to room temperature.	
	Using an oil with a low smoke point.	Touch Cancel , unplug the air fryer, and allow it to cool to room temperature. Choose a neutral oil with a high smoke point, such as Avocado, Canola, Soybean, Safflower, or Rice Bran oil.
	Food residue on the heating coil, in the cooking chamber or on accessories.	Touch Cancel , unplug the air fryer, and allow it to cool to room temperature. Clean the cooking chamber and accessories thoroughly.
	Faulty circuit or heating element.	Touch Cancel , unplug the air fryer, and allow it to cool to room temperature. Contact Customer Care .  Do not attempt to repair the appliance.
White smoke is coming from the air fryer.	Cooking foods with a high fat content, such as bacon, sausage, and hamburger.	Avoid air frying foods with a high fat content. Check the air fryer basket for excess oil or fat and carefully remove as needed after cooking.
	Water is vaporizing, producing thick steam.	Pat dry moist food ingredients before air frying and do not add water or other liquid to the cooking chamber when air frying.
	Seasoning on food has blown into the element.	Be mindful when seasoning food. Spray vegetables and meats with oil before seasoning to help the seasoning stick.
The air fryer is plugged in but will not turn on.	The appliance is not properly plugged in.	Make sure the power cord is in good condition, and is plugged into the outlet firmly.
	Outlet is not powered.	Plug another appliance into the same outlet to test the circuit.
		Plug the air fryer into another outlet.
Air fryer basket is not fully inserted into the cooking chamber.	Make sure the air fryer basket is fully inserted into the cooking chamber.	
All lights flash and a code appears on the display.	E1 Temperature sensor broken circuit.	Contact Customer Care .
	E2 Temperature sensor short circuit.	Contact Customer Care .

Any other servicing must be performed by an authorized representative.