

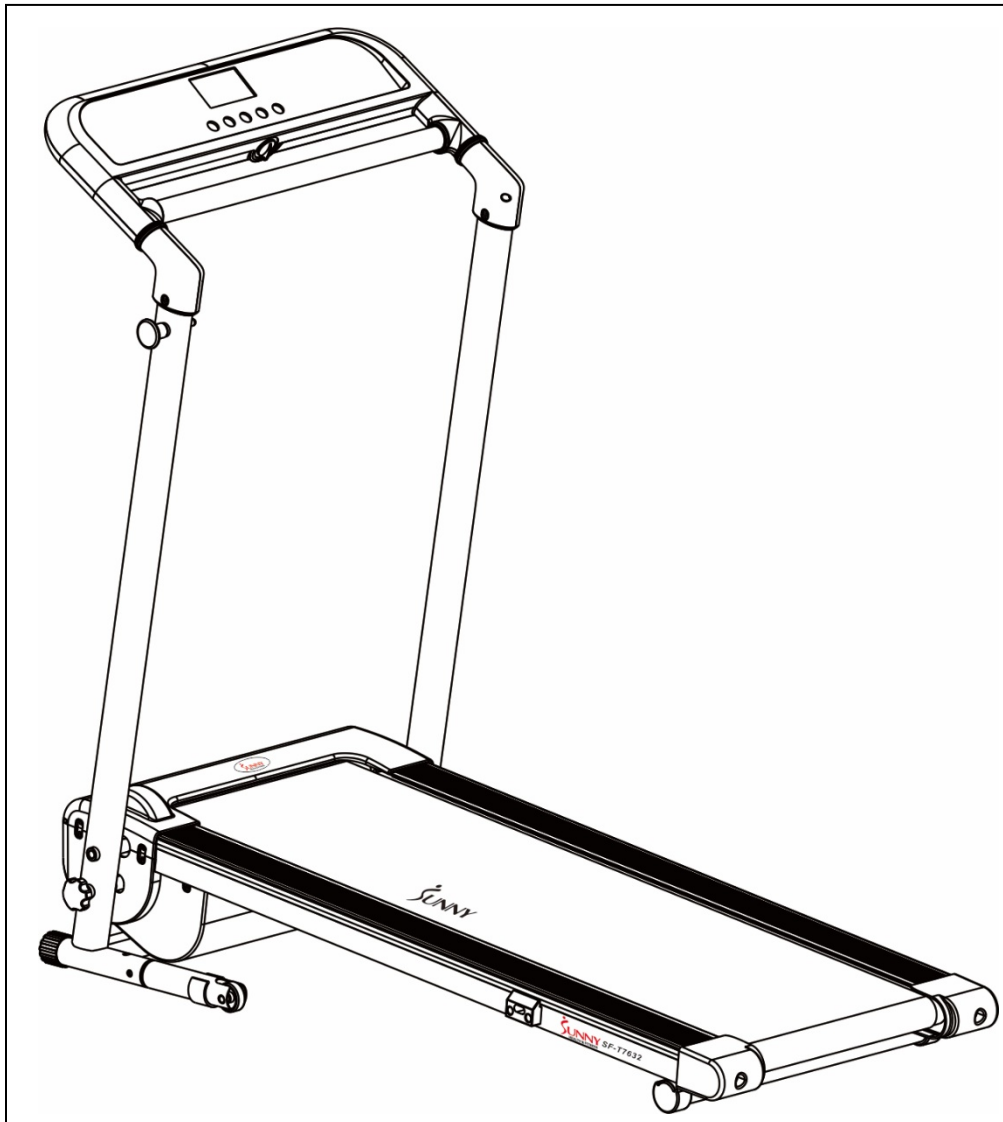

# SPACE SAVING FOLDING TREADMILL

## SF-T7632

### USER MANUAL



**IMPORTANT!** Please retain owner's manual for maintenance and adjustment instructions. Your satisfaction is very important to us, **PLEASE DO NOT RETURN UNTIL YOU HAVE CONTACTED US:** [support@sunnyhealthfitness.com](mailto:support@sunnyhealthfitness.com) or 1- 877 - 90SUNNY (877-907-8669).



# **IMPORTANT SAFETY INSTRUCTION**

When using an electrical appliance, basic precautions should always be followed, including the following:

Read all instructions before using this treadmill.

**DANGER** – To reduce the risk of electrical shock:

1. Always unplug this appliance from the electrical outlet immediately after using and before cleaning.

**WARNING** – To reduce the risk of burns, fire, electric shock, or injury to persons:

1. The treadmill should never be left unattended when plugged in. Unplug from outlet when not in use and before putting on or taking off parts.
2. Use this treadmill only for its intended use as described in this manual. Do not use attachments not recommended by the manufacturer.
3. Never operate this treadmill if it has a damaged cord or plug, if it is not working properly, if it has been dropped or damaged, or dropped into water. Return this treadmill to a service center for examination and repair.
4. Keep the cord away from heated surfaces.
5. Never operate the treadmill with the air openings blocked. Keep the air openings free of lint, hair, and alike items.
6. Never drop or insert any object into any opening.
7. Do not use outdoors.
8. Do not operate where aerosol (spray) products are being used or where oxygen is being administered.
9. To disconnect, turn the treadmill off, then remove plug from outlet.
10. Connect this treadmill to a properly grounded outlet only. See grounding instructions.

**CAUTION:**

To avoid injury, use extreme caution when stepping onto or off of a moving belt. Read instruction manual before using.

*SAVE THESE INSTRUCTIONS*

# **IMPORTANT SAFETY INFORMATION**

We thank you for choosing our product. To ensure your safety and health, please use this equipment correctly. It is important to read this entire manual before assembling and using the equipment. Safe and effective use can only be achieved if the equipment is assembled, maintained, and used properly. It is your responsibility to ensure that all users of the equipment are informed of all warnings and precautions.

1. Before starting any exercise program, you should consult your physician to determine if you have any medical or physical conditions that could put your health and safety at risk or prevent you from using the equipment properly. Your physician's advice is essential if you are taking medication that affects your heart rate, blood pressure or cholesterol level.
2. Be aware of your body's signals. Incorrect or excessive exercise can damage your health. Stop exercising if you experience any of the following symptoms: pain, tightness in your chest, irregular heartbeat, shortness of breath, lightheadedness, dizziness, or feelings of nausea. If you do experience any of these conditions, you should consult your physician before continuing with your exercise program.
3. Keep children and pets away from the equipment. The equipment is designed for adult use only.
4. Use the equipment on a solid, flat level surface with a protective cover for your floor or carpet. To ensure safety, the equipment should have at least 2 feet (60CM) of free space all around it.
5. Ensure that all nuts and bolts are securely tightened before using the equipment. The safety of the equipment can only be maintained if it is regularly examined for damage and/or wear and tear.
6. Always use the equipment as indicated. If you find any defective components while assembling or checking the equipment, or if you hear any unusual noises coming from the equipment during exercise, discontinue use of the equipment immediately and do not use until the problem has been rectified.
7. Wear suitable clothing while using the equipment. Avoid wearing loose clothing that may become entangled in the equipment.
8. Do not place fingers or objects into the moving parts of the equipment.
9. The maximum weight capacity of this unit is 220 pounds (100 KG).
10. The equipment is not suitable for therapeutic use.
11. To avoid bodily injury and/or damage to the product or property, proper lifting and moving is required.
12. Your product is intended for use in cool, dry conditions. You should avoid storage in extreme cold, hot or damp areas as this may lead to corrosion and other related problems.
13. This equipment is designed for indoor and home use only, it is not intended for commercial use!

# **IMPORTANT OPERATING INSTRUCTIONS**

1. Insert the power plug directly into the socket.
2. Read the manual before operating the treadmill.
3. Changes in speed do not occur immediately. Set your desired speed using the adjustment keys on the main console. The speed will increase gradually.
4. While on the treadmill, move with caution as distractions may cause you to lose balance and stray from walking in the center of the running belt. This may result in serious injury.
5. This unit starts at a very low speed. To begin use, hold onto the handrails and stand on the side rails while it starts up, then step onto the running belt it's in motion.
6. Always hold the handrails when making changes in the settings.
7. A safety key is provided for emergency use. The treadmill will function only if the safety key is inserted into the computer console. In case of emergency, remove the safety key to immediately stop the running belt and shut off the treadmill. The display screen will reset once the safety key is reinserted.
8. The console control keys are precisely set and require very little finger pressure to use. To avoid damaging these keys, do not use excessive pressure when operating these controls.
9. This treadmill is designed for adult use only! Children should not be allowed to use or play near this treadmill. When present, children should always be supervised by an adult.
10. Women who are pregnant or nursing should consult a physician before attempting to begin any exercise program.
11. Always stay hydrated during and after exercise.



## **IMPORTANT NOTE:**

**The running belt must be lubricated before the first use! Please see *Page 12* for instructions on how to properly apply lubricant.**

# EXPLODED DIAGRAM

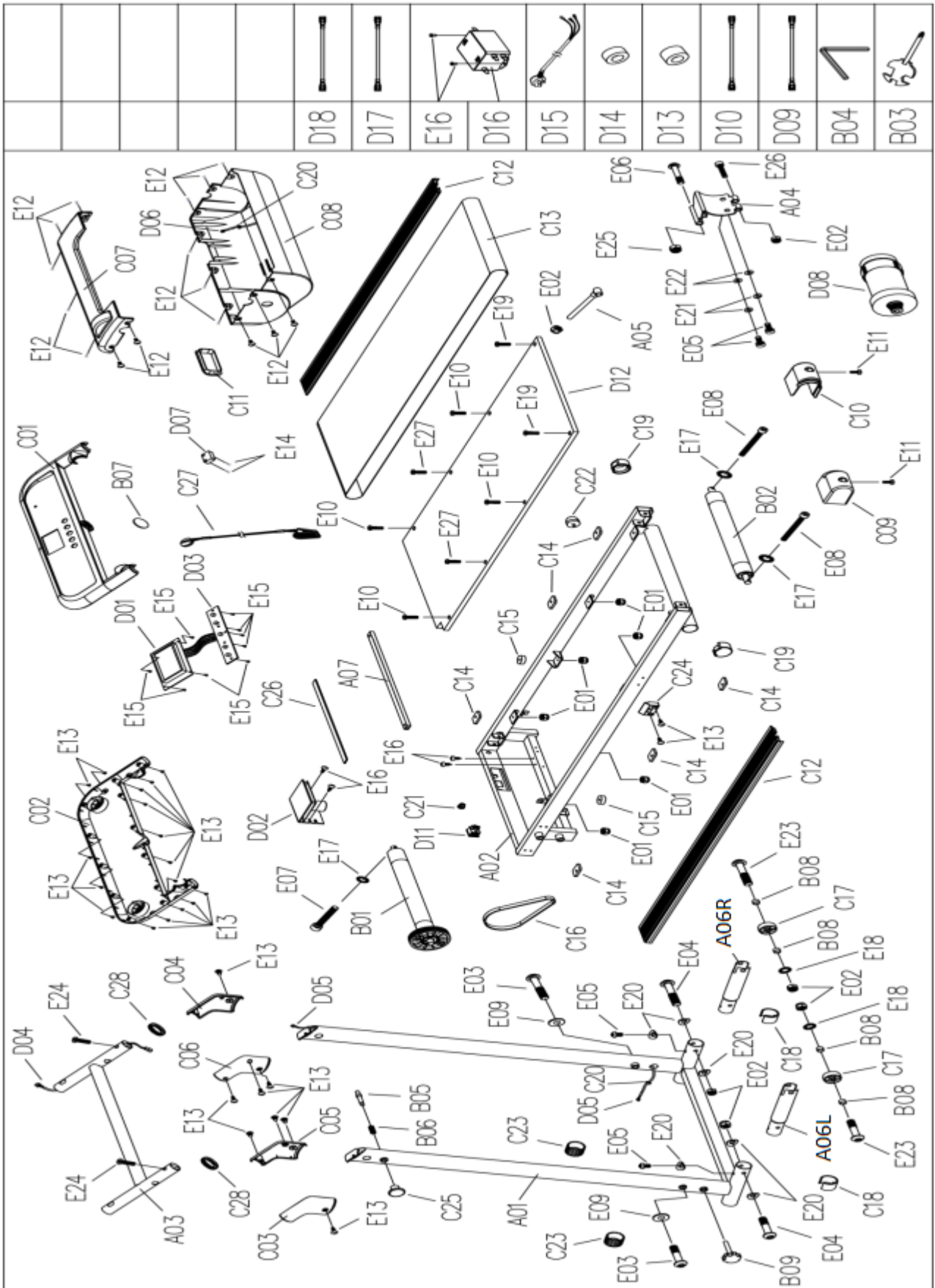

# PARTS LIST

No.	Description	Spec.	Qty
A01	Base Frame		1
A02	Main Frame		1
A03	Console Bracket		1
A04	Motor Frame		1
A05	Adjustable Frame		1
A06	Base Support Tube L/R		2
A07	Running Board Strengthen Tube		1
B01	Front Roller		1
B02	Rear Roller		1
B03	Spanner with Screw Driver	S=13,14,15	1
B04	Allen Wrench	S5	1
B05	Locking Pin Iron		1
B06	Pressure Spring		1
B07	Safety Key Plate		1
B08	Transportation Wheel Bushing		4
B09	Lock Knob		1
C01	Console Top Cover		1
C02	Console Bottom Cover		1
C03	Left Upright Tube Cover		1
C04	Right Upright Tube Cover		1
C05	Left Upright Tube Inner Cover		1
C06	Right Upright Tube Inner Cover		1
C07	Motor Top Cover		1
C08	Motor Bottom Cover		1
C09	Left Rear Cover		1
C10	Right Rear Cover		1
C11	Motor Cover Buckle		1
C12	Side Rail		2
C13	Running Belt		1
C14	Rubber Cushion		6
C15	Blue Cushion		2
C16	Motor Belt		1
C17	Transportation Wheel		2
C18	C Shape Foot Pad 1		2
C19	C Shape Foot Pad 2		2
C20	Ring Protecting Wire Plug		2
C21	Power Wire Buckle		1
C22	Cushion		1
C23	Inner Cap		2
C24	Fixed Block		1

No.	Description	Spec.	Qty
C25	Locking Pin		1
C26	Rubber Cushion		1
C27	Safety Key		1
C28	Handlebar Decoration Ring		2
D01	Console Display		1
D02	Control Board		1
D03	Keyboard		1
D04	Top Signal Wire		1
D05	Middle Signal Wire	1150mm	1
D06	Lower Signal Wire	1600mm	1
D07	Speed Sensor	200mm	1
D08	DC Motor		1
D09	AC Single Line	Blue 350mm	1
D10	AC Single Line	Blown 350mm	1
D11	Power Switch		1
D12	Running Board		1
D13	Magnetic Ring		1
D14	Magnetic Core		1
D15	Power Wire	2150mm	1
D16	Filter		1
D17	AC Single Line	350mm	1
D18	AC Single Line	350mm	1
E01	Nut	M6	6
E02	Nut	M8	6
E03	Bolt	M10*60	2
E04	Bolt	M8*50	2
E05	Bolt	M8*15	4
E06	Bolt	M10*90	1
E07	Bolt	M6*45	1
E08	Bolt	M6*55	2
E09	Flat Washer C	Φ10	2
E10	Bolt	M6*28	4
E11	Bolt	M5*12 (including washer)	2
E12	Bolt	M5*8 (including washer)	16
E13	Screw	ST4.2*12	27
E14	Screw	ST2.9*8	2
E15	Screw	ST2.9*6	9
E16	Screw	ST4.2*12	6
E17	Washer	Φ6	3
E18	Washer	Φ8	2

No.	Description	Spec.	Qty
E19	Bolt	M6*25	2
E20	Arc Washer	Φ8	6
E21	Spring Washer	Φ8	2
E22	Flat Washer C	Φ8	2
E23	Bolt	M8*48	2
E24	Bolt	M8*48	2

No.	Description	Spec.	Qty
E25	Nut	M10	1
E26	Bolt	M8*60	1
E27	Bolt	M6*46	2

## **HARDWARE PACKAGE**

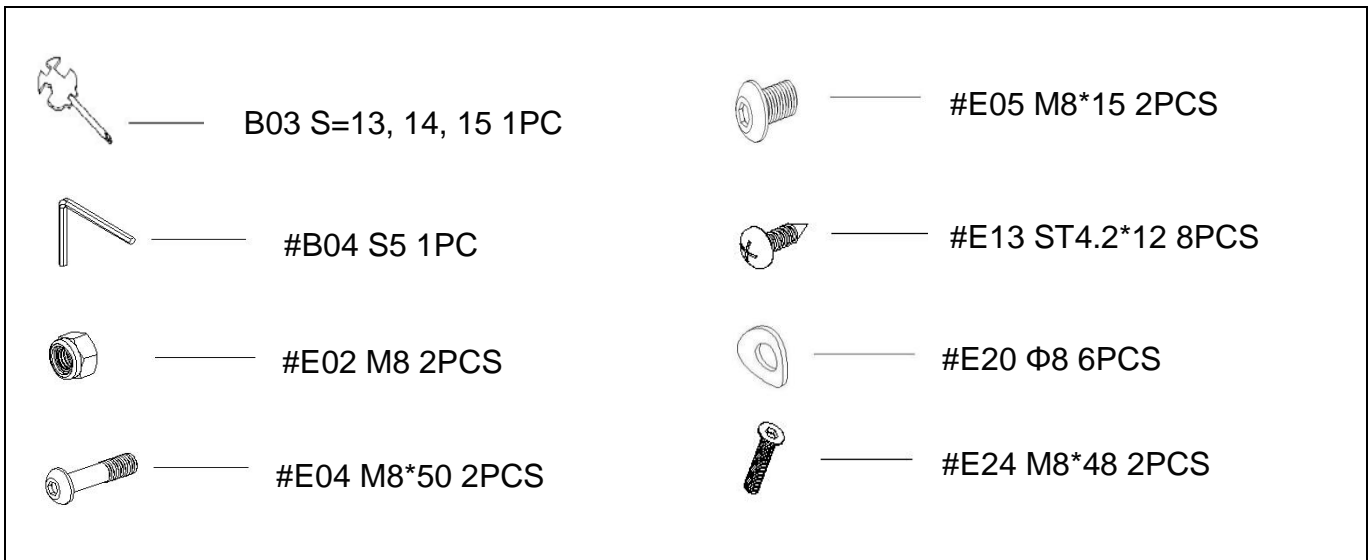

### **Ordering Replacement Parts (U.S. and Canadian Customers only)**

Please provide the following information in order for us to accurately identify the part(s) needed:

- ✓ The model number (found on cover of manual)
- ✓ The product name (found on cover of manual)
- ✓ The part number found on the “EXPLODED DIAGRAM” and “PARTS LIST” (found near the front of the manual)

Please contact us at [support@sunnyhealthfitness.com](mailto:support@sunnyhealthfitness.com) or 1- 877 - 90SUNNY (877-907-8669).

# ASSEMBLY INSTRUCTIONS

We value your experience using Sunny Health and Fitness products. For assistance with parts or troubleshooting, please contact us at [support@sunnyhealthfitness.com](mailto:support@sunnyhealthfitness.com) or 1-877-90SUNNY (877-907-8669).

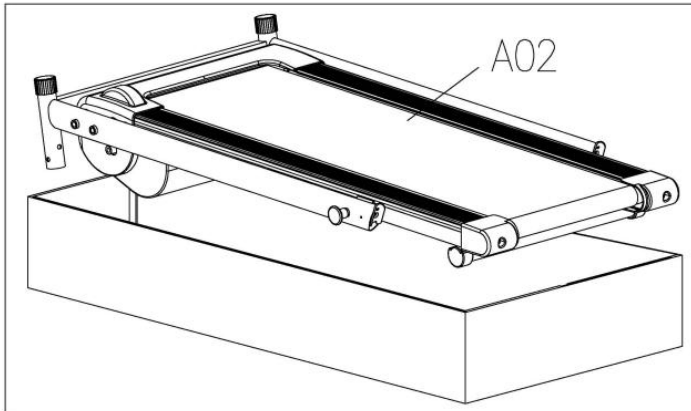

## STEP 1:

**NOTE:** We recommend having two people do the assembly.

Open the carton box and remove contents. Place the **Main Frame (No. A02)** on level ground. Ensure that you have a work area that is clean and has adequate space.

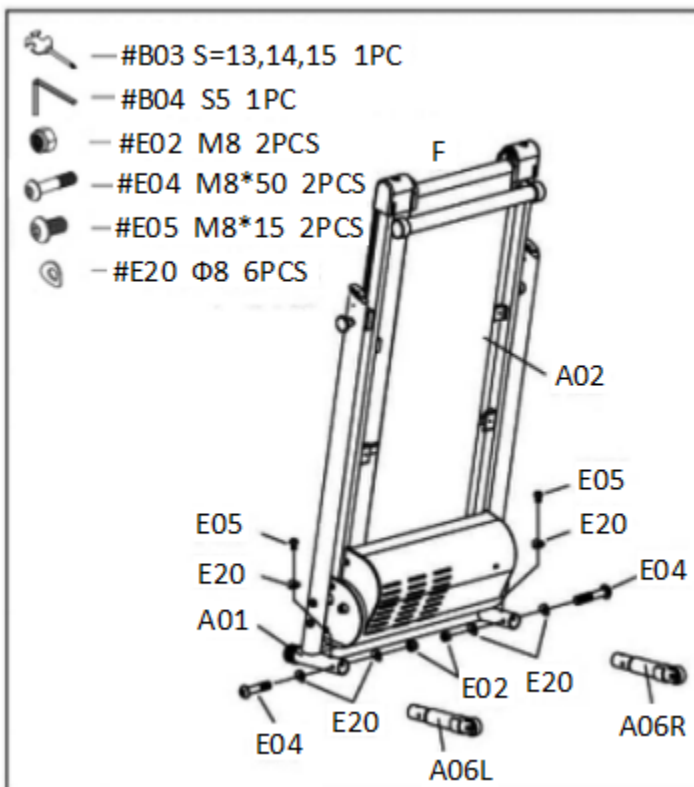

## STEP 2:

**NOTE:** Support **Main Frame (No. A02)** at position “F” with one hand to prevent it from falling down during assembly.

Attach the **Left Base Support Tube (No. A06L)** to **Base Frame (No. A01)**. Use **Allen Wrench (No. B04)** and **Spanner with Screw Driver (No. B03)** to screw **Bolt (No. E04)**, 2 **Arc Washers (No. E20)**, and **Nut (No. E02)** into the **Base Frame (No. A01)**.

Then, screw the **Bolt (No. E05)** and **Arc Washer (No. E20)** into the **Base Frame (No. A01)**.

Repeat the step above to assemble the **Right Base Support Tube (No. A06R)** to the **Base Frame (No. A01)**.

We value your experience using Sunny Health and Fitness products. For assistance with parts or troubleshooting, please contact us at [support@sunnyhealthfitness.com](mailto:support@sunnyhealthfitness.com) or 1-877-90SUNNY (877-907-8669).

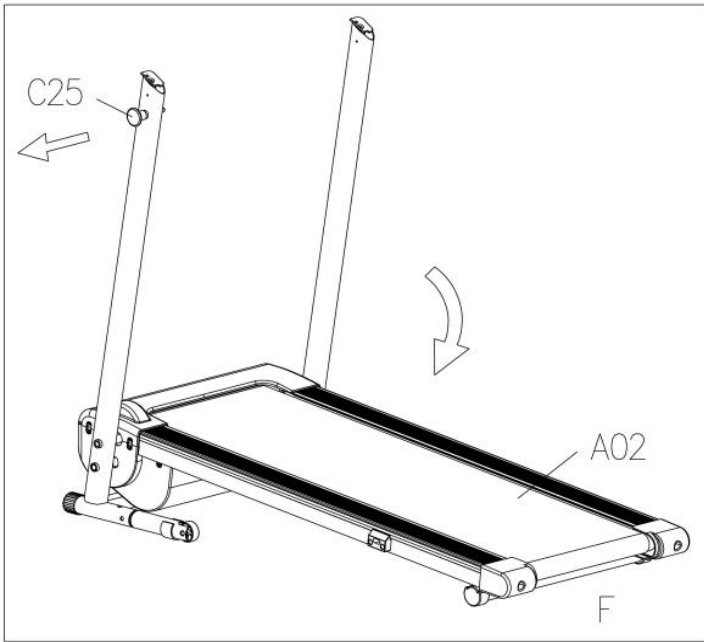

### STEP 3:

**NOTE:** To avoid any possible injury, please hold on the **Main Frame (No. A02)** at position “**F**” before you pull the **Locking Pin (No. C25)** and ensure that the space directly underneath it is clear of any objects. Once the **Main Frame (No. A02)** is released, please continue to hold on until it reaches the floor.

Pull the **Locking Pin (No. C25)** and lower the **Main Frame (No. A02)** to the floor.

**NOTE:** The **Locking Pin (No. C25)** will snap back into the treadmill. It does not detach from the treadmill.

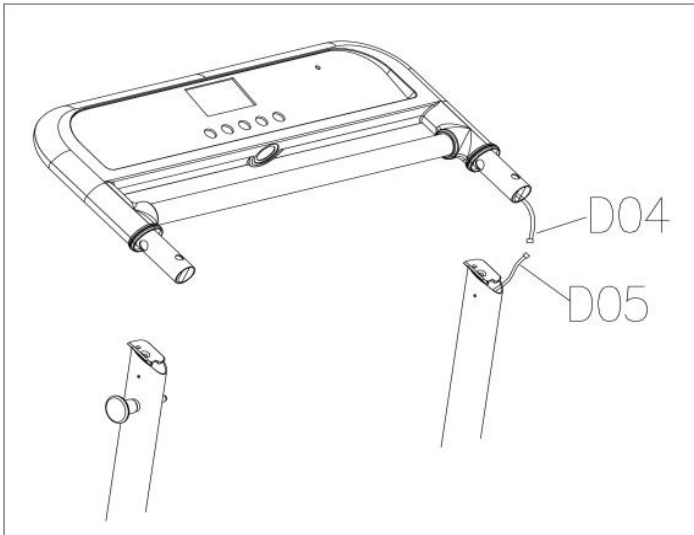

### STEP 4:

Connect the **Top Signal Wire (No. D04)** to the **Middle Signal Wire (No. D05)**.

We value your experience using Sunny Health and Fitness products. For assistance with parts or troubleshooting, please contact us at [support@sunnyhealthfitness.com](mailto:support@sunnyhealthfitness.com) or 1-877-90SUNNY (877-907-8669).

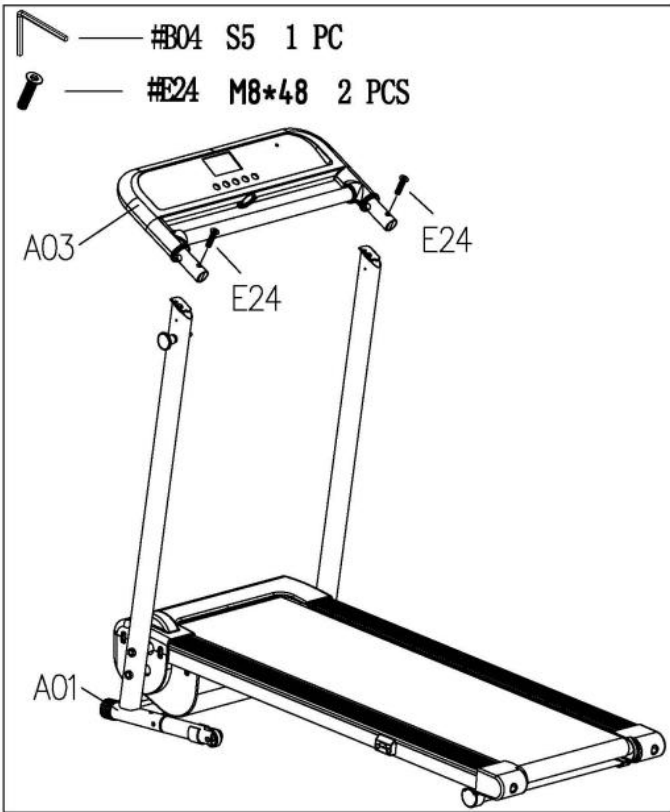

### STEP 5:

Attach the **Console Bracket (No. A03)** to the **Base Frame (No. A01)** with 2 **Bolts (No. E24)**. Tighten using **Allen Wrench (No. B04)**.

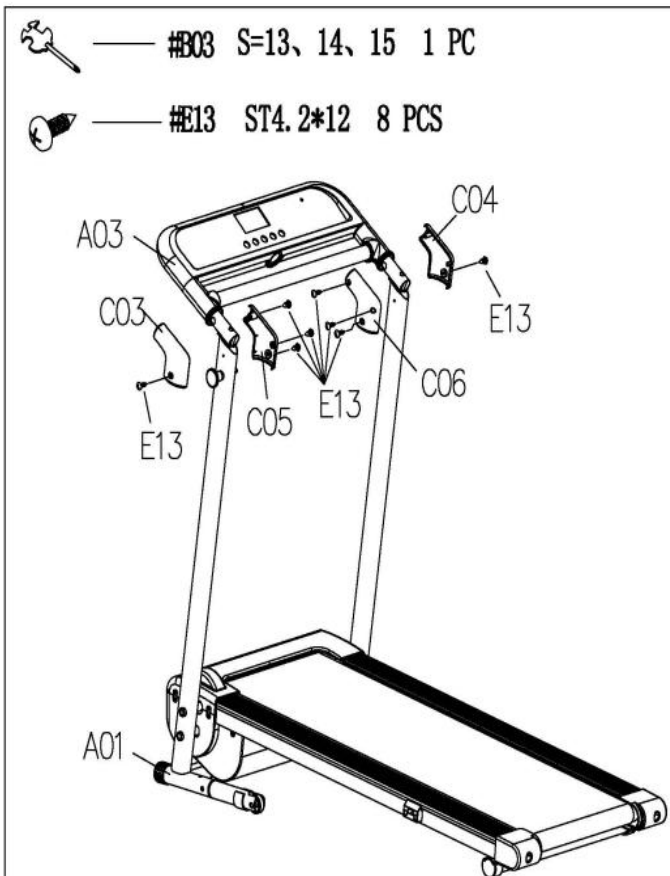

### STEP 6:

Attach the **Left & Right Upright Tube Covers (No. C03 & No. C04)** and **Left & Right Upright Tube Inner Covers (No. C05 & No. C06)** to the **Base Frame (No. A01)** and **Console Bracket (No. A03)** with 8 **Screws (No. E13)**. Tighten using **Spanner with Screw Driver (No. B03)**.

We value your experience using Sunny Health and Fitness products. For assistance with parts or troubleshooting, please contact us at [support@sunnyhealthfitness.com](mailto:support@sunnyhealthfitness.com) or 1-877-90SUNNY (877-907-8669).

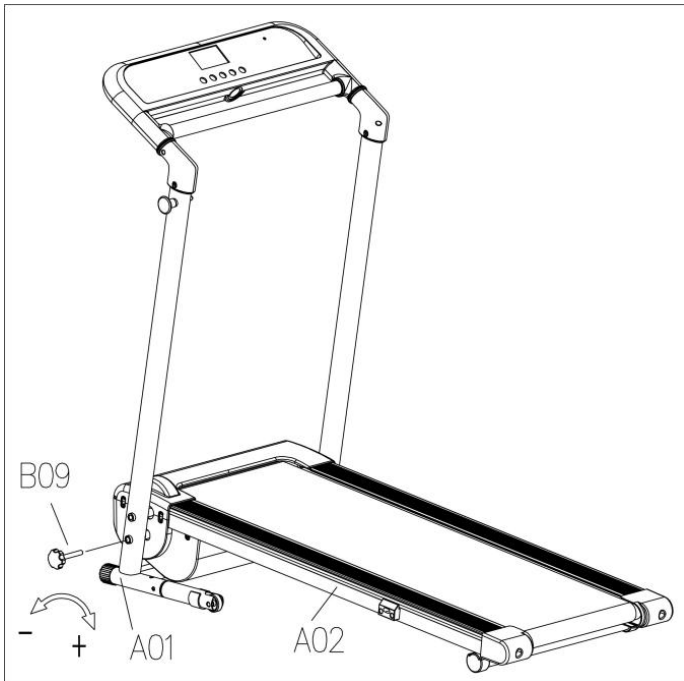

### STEP 7:

Insert **Lock Knob (No. B09)**. Secure the **Base Frame (No. A01)** to **Main Frame (No. A02)** by turning **Lock Knob (No. B09)** *clockwise* until tight.

*The assembly is complete!*



### IMPORTANT NOTE!

You will need to lubricate your treadmill before the first use. See *Page 12*.

# MAINTENANCE & CARE

General cleaning will help prolong the life and performance of your treadmill. Keep the unit clean and maintained by dusting the components on a regular basis. Clean both sides of the **Running Belt (No. C13)** to prevent dust from accumulating underneath. Keep your running shoes clean so that dirt from your shoes does not wear the **Running Board (No. D12)** and **Running Belt (No. C13)**. Clean the surface of the **Running Belt (No. C13)** with a clean damp cloth.

To better maintain the treadmill and prolong its life it is suggested that the treadmill be powered off for 10 minutes every 2 hours and fully powered off whenever not in use.

## **CENTERING THE RUNNING BELT:**

Place the treadmill on level ground and set it at 3-5 MPH to check if the **Running Belt (No. C13)** drifts from the center.

1. If the **Running Belt (No. C13)** drifts to the right, turn the right adjusting bolt  $\frac{1}{4}$  turn *clockwise*, then turn the left adjusting bolt  $\frac{1}{4}$  turn *counter-clockwise*. If the **Running Belt (No. C13)** does not move, repeat this step until it centers. Refer to Figure A.

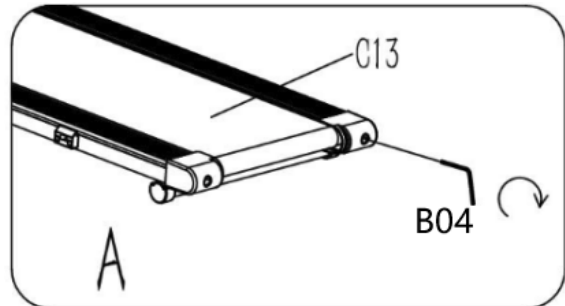

2. If the **Running Belt (No. C13)** drifts to the left, turn the left adjusting bolt side  $\frac{1}{4}$  turn *clockwise*, then turn the right adjusting bolt  $\frac{1}{4}$  turn *counter-clockwise*. If the **Running Belt (No. C13)** does not move, repeat this step until it centers. Refer to Figure B.

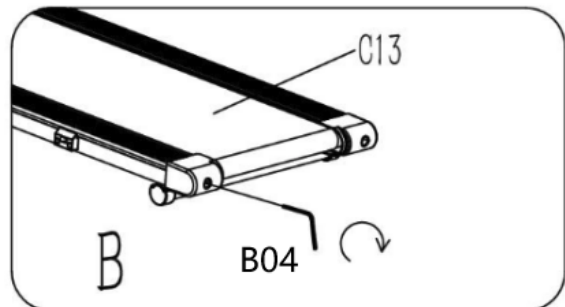

3. Over time, the **Running Belt (No. C13)** will loosen. To tighten the **Running Belt (No. C13)** turn the **Left & Right** adjusting bolts one full turn *clockwise*, check the tension of the **Running Belt (No. C13)**. Continue this process until **Running Belt (No. C13)** is at the correct tension. Make sure to adjust both sides equally to ensure correct belt alignment. Refer to Figure C.

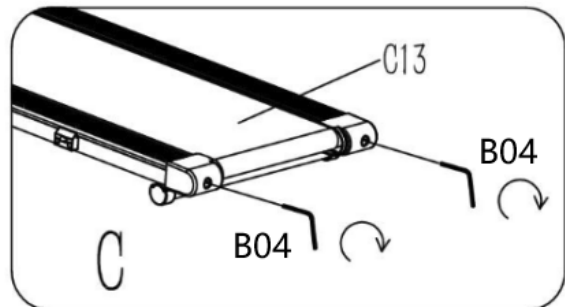

# LUBRICATING THE TREADMILL

## **\*IMPORTANT NOTE:**

You will need to lubricate your treadmill before the first use.

## **RUNNING BELT & TREADMILL LUBRICANT:**

Lubricating the **Running Board (No. D12)** and **Running Belt (No. C13)** is essential as the friction affects the life span and operations of the treadmill. Inspect the **Running Board (No. D12)** and **Running Belt (No. C13)** regularly. If you find any wear on the **Running Board (No. D12)**, please contact us at: [support@sunnyhealthfitness.com](mailto:support@sunnyhealthfitness.com).

**WARNING:** Always unplug the treadmill from the electrical outlet before cleaning, lubricating, or repairing the unit.

## **HOW TO LUBRICATE:**

1. Raise the **Running Belt (No. C13)** up on one side and apply lubricant to the **Running Board (No. D12)**. Use a rag to thoroughly wipe the lubricant over the **Running Board (No. D12)**. Repeat this process for the other side.
2. The moving parts should turn freely and quietly. Abnormal moving parts will affect the safety of the treadmill. Inspect and tighten bolts regularly.
3. To better maintain the treadmill and prolong its lifespan, it is suggested that maintenance be done on a regular basis.
4. **DO NOT LOOSEN OR MAKE ANY ADJUSTMENTS TO THE RUNNING BELT WHILE APPLYING LUBRICANT.** A loose **Running Belt (No. C13)** will result in the runner sliding off during use, while too tight of a **Running Belt (No. C13)** will negatively affect the motor's performance and create more friction between the roller and **Running Belt (No. C13)**. The most suitable tightness for the **Running Belt (No. C13)** is when it is pulled out **50-75mm** from the **Running Board (No. D12)**.

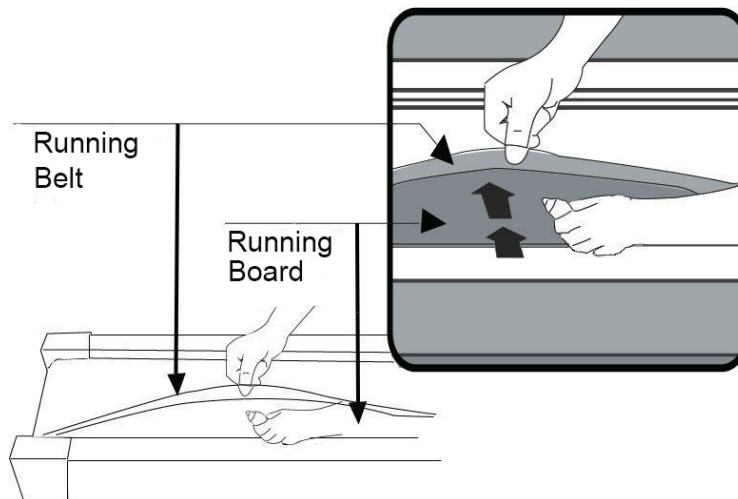

## **Recommended Time Table:**

Light user (less than 3 hours/ week)	<i>every six months</i>
Medium user (3-5 hours/ week)	<i>every three months</i>
Heavy user (more than 5 hours/ week)	<i>every two months</i>

# FOLDING INSTRUCTIONS

## FOLDING:

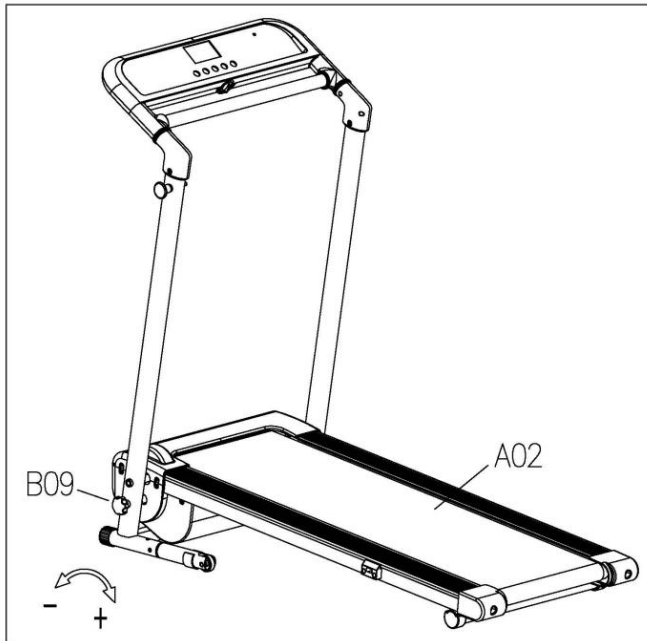

Loosen the **Lock Knob (No. B09)** counter-clockwise and pull it out. Fold the **Main Frame (No. A02)**.

**NOTE:** Remember where you keep the **Lock Knob (No. B09)** after you pull it out. You will need it when you unfold the treadmill.

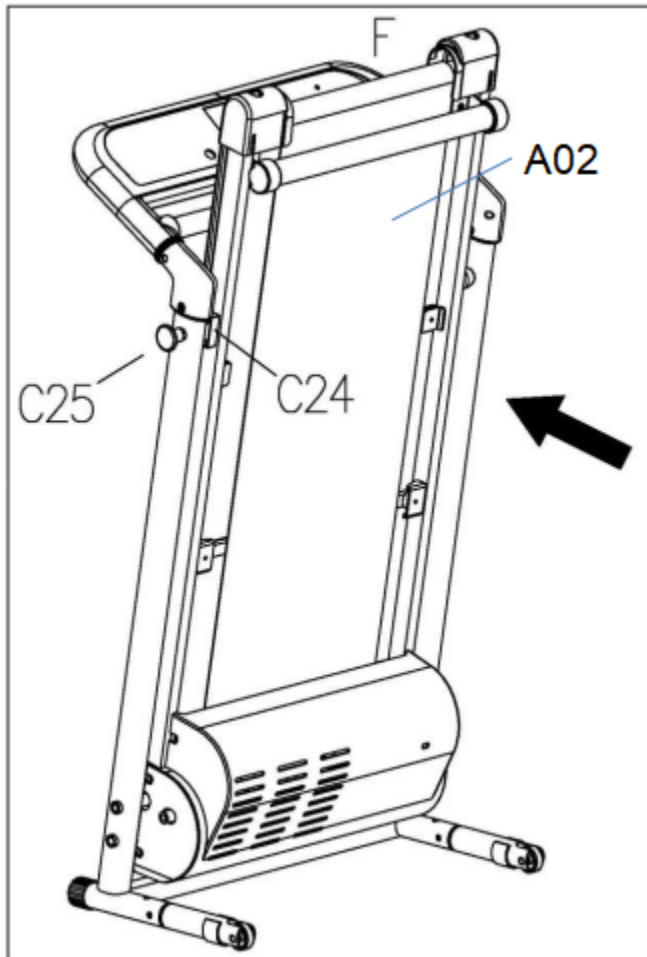

Pull out the **Locking Pin (No. C25)** with one hand, then lift up the **Main Frame (No. A02)** at position "F" with the other hand until the **Locking Pin (No. C25)** snaps into the hole of **Fixed Block (No. C24)**.

## UNFOLDING:

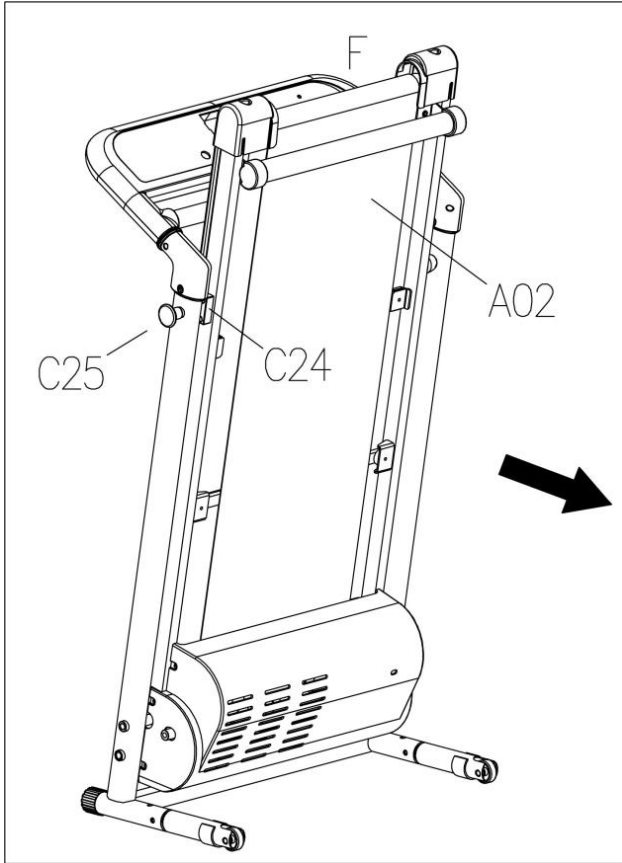

**NOTE:** Before lowering the **Main Frame (No. A02)**, ensure that the space directly underneath is clear of any objects.

To avoid any possible injury, please hold on the **Main Frame (No. A02)** at position “F” before you pull the **Locking Pin (No. C25)**. Once the **Main Frame (No. A02)** is released, continue to hold on at position “F” until it reaches the floor.

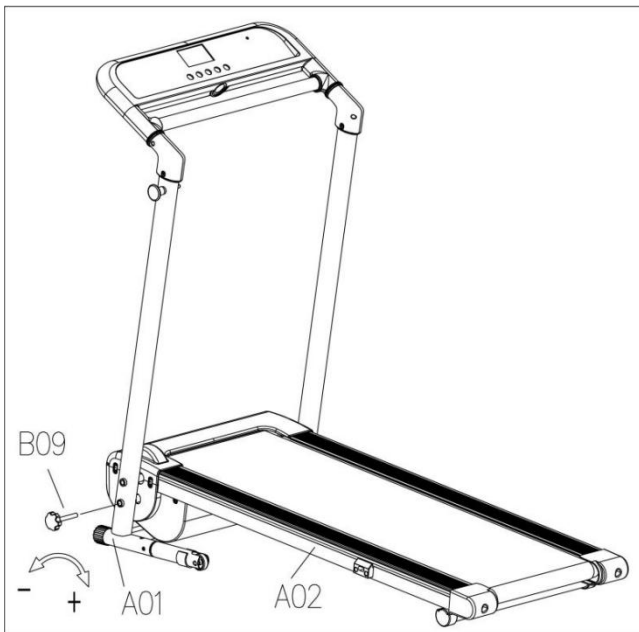

Secure **Base Frame (No. A01)** into **Main Frame (No. A02)** by inserting **Lock Knob (No. B09)** and turning *clockwise* until tight.

## HOW TO MOVE THE TREADMILL

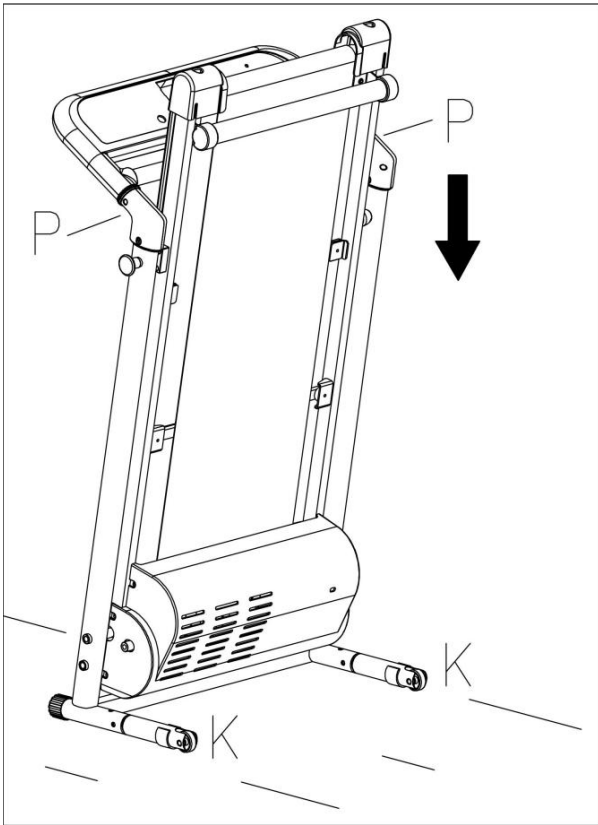

Before attempting to move the treadmill, please make sure that it has been properly folded. Unplug the power cord.

To tilt, start by placing one hand at position "P" to support the top end of the treadmill. Next, place one foot at position "K" to hold the bottom end of the treadmill steady. With your foot at "K", slowly tilt the top of the treadmill downward towards the ground. Once the Main Frame "P" reaches a low enough point, the wheels of the treadmill touch the ground.

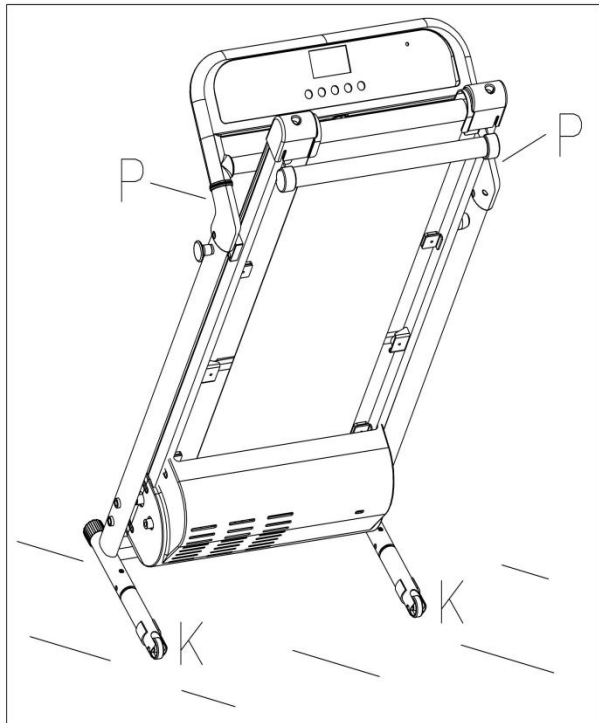

To transport, hold the treadmill from position "P" and tilt until the wheel's "K" are able to move on the ground.

## HOW TO USE SAFETY KEY

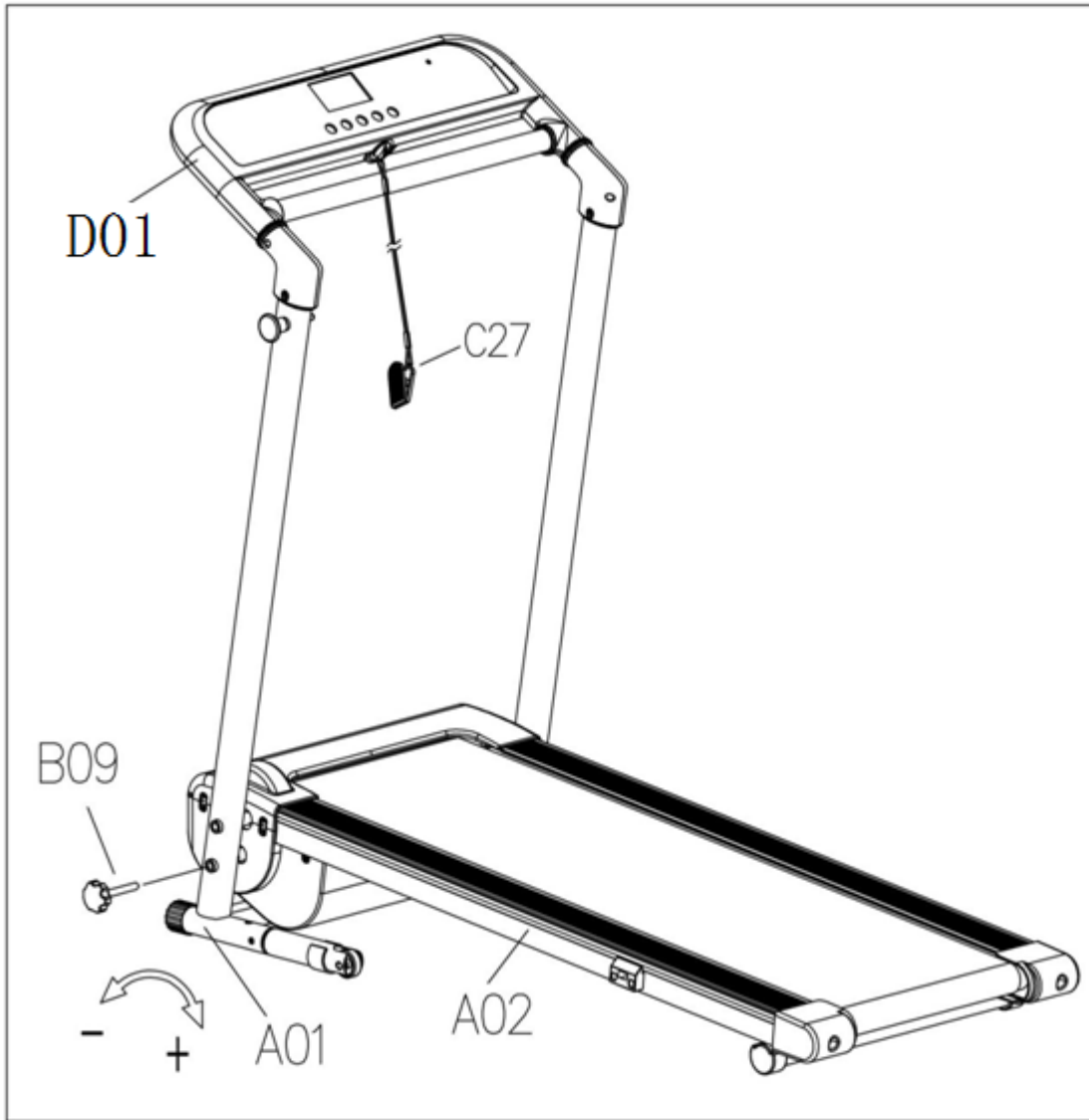

Secure **Base Frame (No. A01)** into **Main Frame (No. A02)** by inserting **Lock Knob (No. B09)** and turning *clockwise* until tight.

Insert the **Safety Key (No. C27)** into the magnetic area of the **Console Display (No. D01)** and clip to your clothes.

**Note:** In an emergency, pull out the **Safety Key (No. C27)**, and the treadmill will stop.

# **IMPORTANT ELECTRICAL INFORMATION**

**WARNING:** This treadmill requires a power source of **8 amps (100-120 V)** in order to properly operate. For your safety, as well as the safety of others, verify that the power source is correct before plugging in the equipment. Any power source above or below this level could cause significant damage to the equipment and/or user.

## **GROUNDING METHODS:**

This product must be grounded. Should the treadmill malfunction or breakdown, grounding provides a path of least resistance for electric current to reduce the risk of electric shock. This product is equipped with a plug that has an equipment-grounding conductor and a grounding plug. The plug must be plugged into an appropriate outlet that is properly installed and grounded in accordance with all local codes and ordinances. Ensure that the product is connected to an outlet with the same configuration as the plug. Do not use an adaptor for this product.

This product is for use on a nominal 100-120V circuit and has a grounding plug that looks like the plug illustrated in sketch A.

## **DANGER:**

Improper connection of the equipment-grounding conductor can result in risk of electric shock. Check with a qualified electrician or serviceman if you are unsure whether the product has been properly grounded. Do not modify the plug provided with the product. If it will not fit the outlet, have a proper outlet installed by a qualified electrician.

## **WARNING!**

1. **NEVER** use a ground fault circuit interrupt (GFCI) wall outlet with this treadmill. Route the power cord away from all moving parts of the treadmill including the elevation mechanism and transportation wheels.
2. **NEVER** operate the treadmill using a generator or UPS power supply.
3. **NEVER** remove any cover on this treadmill without first disconnecting power cord.
4. **NEVER** expose the treadmill to rain or moisture. This treadmill is not designed for outdoor use or use in any other high humidity environment.

### **GROUNDING METHOD**

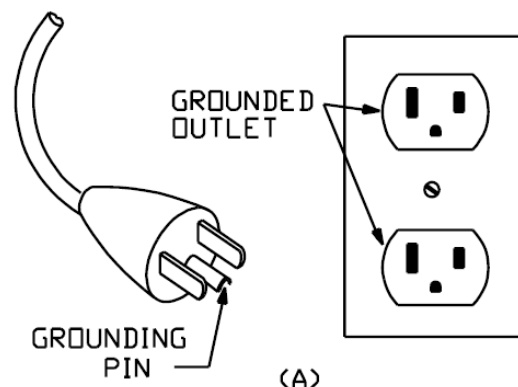

# THE DISPLAY CONSOLE

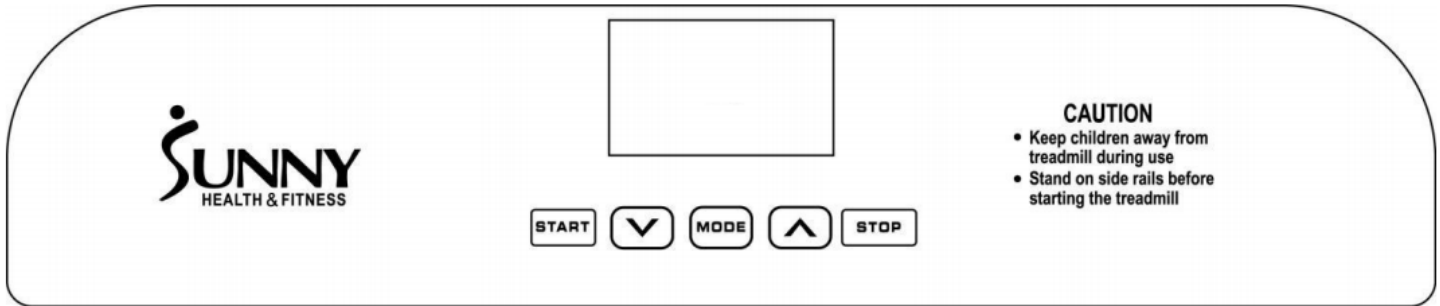

## DISPLAY

**SPEED:** Displays current speed (range 0.5-7.0 MPH). When in setting mode, the window displays H-1, H-2, H-3.

**TIME:** Displays the running time. Displays the exercise time from 0:00-99:59 MINS. If the time reaches 99:59, the treadmill will stop smoothly and display “End” and will enter standby mode after 5 seconds. When in countdown mode, it will count from the setting time to 0:00. When the countdown reaches to 0:00, the treadmill will stop smoothly and show “End” and will enter into standby mode after 5 seconds.

**DISTANCE:** Displays the distance traveled (range 0.0-99.9 MILES). When the distance reaches 99.9 MILES, it will reset to 0.00 and begin counting again from 0.0. When in countdown mode, it will count down from the distance you set to 0.00. When it reaches 0.00, the treadmill will stop smoothly and display “End”, then enter standby mode after 5 seconds.

**CALORIES:** Displays the user’s calories burned (range 0-999 KCAL). When it reaches 999 KCAL, it will start again from 0. In countdown mode, it will count from the number of calories you set to 0. When it reaches 0, the treadmill will stop smoothly and show “End”, and then enter standby mode after 5 seconds.

PROGRAMS	Initial	Default Value	Set Range	Display Range
TIME (MIN:SECOND)	0:00	15:00	5:00-99:00	0:00—99:59
SPEED (MPH)	0.5	0.5	0.5-7.0	0.5-7.0
DISTANCES (MILE)	0	1.0	0.5-99.9	0.0—99.9
CALORIE (KCAL)	0	50	10-999	0—999

## FUNCTION KEYS

**START:** To start the treadmill, insert the magnetic end of the **Safety Key (No. C27)** into the computer console then press the **START** button. This treadmill requires the **Safety Key (No. C27)** in order to start at default setting speed 0.5 MPH.

**STOP:** This button can **PAUSE** and **STOP** the treadmill. When in use, press this button once to **PAUSE**: your workout and the current workout data will still be shown. Press **STOP** again to end your workout session and all data from this session will be deleted.

**MODE:** Press this button to select a MODE. Pressing once will enter H1, the TIME countdown mode starting from 15:00 MINS. H2 is the DISTANCE countdown mode starting from 1.0 MILE and H3 is the CALORIES countdown mode which starts from 50 KCAL. When setting each mode, you can press +/- to increase or decrease the preset H1, H2, H3 settings then press **START** to start the treadmill.

**SPEED +/- SPEED -:** Press the SPEED +/- buttons to increase or decrease the speed in increments of 0.1 MPH. Pressing and holding either of these buttons for a duration of over 0.5 second will increase or decrease the speed continually.

## LUBRICATION REMINDER

Your treadmill needs lubrication maintenance every 188 miles. When it is time for maintenance, the treadmill beeps every 10 seconds and displays an "OIL" icon on your LCD display. Please read the LUBRICATING THE TREADMILL on Page 12 to learn the proper steps to lubricating your treadmill. Apply the lubricating oil to the middle of the running board on both sides. After application, press and hold the **STOP** button for 3 seconds to clear the "OIL" reminder.

# TREADMILL FUNCTIONS

## **SAFETY LOCK FUNCTION:**

Removing the **Safety Key (No. C27)** from the console while the treadmill is running, and the treadmill will stop immediately. Once the treadmill reaches a full stop, the display will show “- - -” and the treadmill will beep 3 times. To start the treadmill again, insert the magnetic end of the **Safety Key (No. C27)** into the console and press the **START** button.

## **POWER SAVE FUNCTION:**

When the treadmill has been inactive for 10 minutes, it will enter Power Saving Mode. While the treadmill is in this mode, the display of the console will be turned off. To turn it back on, press any button.

## **I POWER ON:**

Flick the power switch to this symbol to turn on the treadmill.

## **O POWER OFF:**

Flick the power switch to this symbol to turn the treadmill off at any time, including while the treadmill is in use.

## **SAFETY NOTE:**

1. We recommend that you maintain a slow speed at the beginning of a session and hold the handrails until you become familiar with the treadmill.
2. Insert the magnetic end of the **Safety Key (No. C27)** into the console and attach the safety clip to your clothing before starting your workout. To end your workout, press the **STOP** button or remove the **Safety Key (No. C27)** and the treadmill will stop immediately.

# EXERCISE INSTRUCTIONS

## GETTING STARTED:

Before starting any exercise program, you should consult your physician to determine if you have any medical or physical conditions that could put your health and safety at risk or prevent you from using the treadmill properly.

Be aware of your body's signals. Incorrect or excessive exercise can damage your health. Stop exercising immediately if you experience any of the following symptoms: pain, tightness in your chest, irregular heartbeat, shortness of breath, lightheadedness, dizziness, or feelings of nausea.

Get to know your treadmill. Before attempting to use the treadmill, take some time to familiarize yourself with the controls.

1. Once you get on, stand with your feet on the side rails and stabilize yourself by holding onto the handrails.
2. Next, attach the clip end of the **Safety Key (No. C27)** to your clothes and insert the magnetic end of the **Safety Key (No. C27)** into the console.
3. Press the **START** button to start the treadmill.
4. The treadmill will start at the system default setting speed of **0.5 MPH**. When you feel comfortable, slowly increase this speed.
5. When you are finished with your workout, press the **STOP** button to stop the treadmill or you can remove the magnetic end of the **Safety Key (No. C27)** to stop the treadmill.

# TROUBLESHOOTING

PROBLEM	POSSIBLE CAUSE	SUGGESTED ACTION
Treadmill will not start.	Not plugged in.	Plug power cord into outlet.
	<b>Safety Key (No. C27)</b> is not inserted.	Insert <b>Safety Key (No. C27)</b> .
Running belt not centered.	Running belt tension is not correct on the left or right sides of the running board.	Tighten the left and right adjusting bolts of the rear roller.
Console not working.	Wires from the console and bottom control board are not properly connected.	Check wire connections from the console to the bottom control board.
	Transformer is damaged.	If the transformer is damaged, contact customer service.
E01 or E13: Message failure.	Wires from the console and bottom control board not properly connected.	Check wire connections from the console to the bottom control board. If the wire has been punctured or damaged, you will need to replace it. If the problem is not rectified, you may need to replace the bottom control board.
E02: Burst clash protection.	Incoming voltage is lower than 50% of the required voltage.	Check that the incoming power supply is the correct voltage.
E03: No speed sensor signal.	Speed sensor signal cannot be received by the control board.	Check that the sensor wire is properly connected. If damaged, replace wire. Check to see if the magnetic sensor is damaged, replace if necessary.
E05: Current overload protection (Self Protecting System).	The incoming voltage is too low or too high. The control board is damaged.	Restart the treadmill. Check the incoming voltage to ensure its correct. Check the control board, replace if damaged.
	A moving part of the treadmill is stuck and therefore the motor is unable to rotate properly.	Inspect moving parts of the treadmill to ensure that they are operating correctly. Check the motor, listen for strange noise, and check for a burning smell. Replace the motor if necessary.

E06: Motor Abnormality.	The motor wire is not connected, or the motor is damaged.	Check motor wires to see if the motor is connected. If the wire has been punctured or damaged, you will need to replace it. If the problem is not rectified, you may need to replace the motor.
E08: Control Board Abnormality.	The control board is not connected.	Check the upper and middle wires to see if the control board is connected. If the wire has been punctured or damaged, you will need to replace it. If the problem is not rectified, you may need to replace the control board.
E10: Motor Abnormality.	Motor is short-circuited.	Replace with a new motor.
	A moving part of the treadmill is stuck and therefore the motor is unable to rotate properly.	Inspect moving parts of the treadmill to ensure that they are operating correctly and lubricate treadmill. Replace the motor if necessary.

**NOTE: If you are unable to resolve an issue using the troubleshooting guide above, please contact Customer Service at [support@sunnyhealthfitness.com](mailto:support@sunnyhealthfitness.com).**

# CONNECT WITH US

FOR FITNESS  
ARTICLES, VIDEOS  
& WORKOUTS



@SUNNYHEALTHANDFITNESS



@SUNNYHEALTHFITNESS



@SUNNYHEALTHFIT



/SUNNYHEALTHFITNESS



/SUNNYHEALTHANDFITNESS

WWW.SUNNYHEALTHFITNESS.COM