

User Manual of Product 1:

BISSELL 24613 Pet Hair Eraser Turbo Plus Lightweight Vacuum, Tangle-Free Brush Roll, Powerful Pet Hair Pick-up, SmartSeal Allergen System, Specialized Pet Tools, Easy Empty



PET HAIR ERASER[®] TURBO PLUS

LIGHTWEIGHT & POWERFUL
PET HAIR PICK UP

QUICK START/USER GUIDE
2281/2461 Series



More of a video person? Look for this icon and go online for an instructional how-to video at

www.BISSELL.com

IMPORTANT SAFETY INSTRUCTIONS

READ ALL INSTRUCTIONS BEFORE USING YOUR UPRIGHT VACUUM.

Always connect to a polarized outlet (one slot is wider than the other). Unplug from outlet when not in use and before conducting maintenance. When using an electrical appliance, basic precautions should be observed, including the following:

WARNING

TO REDUCE THE RISK OF FIRE, ELECTRIC SHOCK OR INJURY:

- » Do not leave vacuum cleaner when it is plugged in. Unplug from outlet when not in use and before servicing.
- » Do not use outdoors or on wet surfaces.
- » Do not allow to be used as a toy. Close attention is necessary when used by or near children.
- » Do not use for any purpose other than described in this user guide. Use only manufacturer's recommended attachments.
- » Do not use with damaged cord or plug. If appliance is not working as it should, has been dropped, damaged, left outdoors, or dropped into water, have it repaired at an authorized service center.
- » Do not pull or carry by cord, use cord as a handle, close a door on cord, or pull cord around sharp edges or corners. Do not run appliance over cord. Keep cord away from heated surfaces.
- » Do not unplug by pulling on cord. To unplug, grasp the plug, not the cord.
- » Do not handle plug or vacuum cleaner with wet hands.
- » Do not put any object into openings. Do not use with any opening blocked; keep openings free of dust, lint, hair, and anything that may reduce air flow.
- » Keep hair, loose clothing, fingers, and all parts of body away from openings and moving parts.
- » Turn OFF all controls before plugging or unplugging vacuum cleaner.
- » Use extra care when cleaning on stairs.
- » Do not use to pick up flammable or combustible materials (lighter fluid, gasoline, kerosene, etc.) or use in areas where they may be present.
- » Do not use vacuum cleaner in an enclosed space filled with vapors given off by oil-based paint, paint thinner, some moth-proofing substances, flammable dust, or other explosive or toxic vapors.
- » Do not use to pick up toxic material (chlorine bleach, ammonia, drain cleaner, etc.).
- » Do not pick up anything that is burning or smoking, such as cigarettes, matches or hot ashes.
- » Do not use without filters in place.
- » Do not pick up hard or sharp objects such as glass, nails, screws, coins, etc.
- » Use only on dry, indoor surfaces.
- » Keep appliance on a level surface.
- » Do not carry the vacuum cleaner while it is running.
- » Unplug before connecting or disconnecting the TurboBrush® Tool.

SAVE THESE INSTRUCTIONS

This model is for household use only.

WARNING

- » Plastic film can be dangerous. To avoid danger of suffocation, keep away from children.
- » Do not plug in your vacuum cleaner UNTIL you are familiar with all instructions and operating procedures.
- » To reduce the risk of electrical shock, turn Power Switch OFF and disconnect polarized plug from electrical outlet BEFORE performing maintenance or troubleshooting checks.

Quick Start Guide

READ COMPLETE USER GUIDE FOR FULL INSTRUCTIONS ON USE, MAINTENANCE AND IMPORTANT SAFETY NOTICES.

Assembly

1



Slide end of wand into top of base. It will “click” when inserted correctly.

2

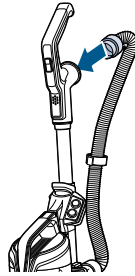

Attach Stretch Hose by lining the tabs on the cuff with the notches on the back of the vacuum. Twist clockwise to lock hose into place.

3

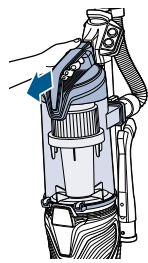

Remove Dirt Tank. Press the Dirt Tank Release Button and pull away from vacuum.

4

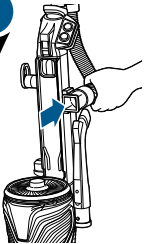

Attach end of hose to vacuum by sliding square cuff into the bracket below the Power Switch.

5

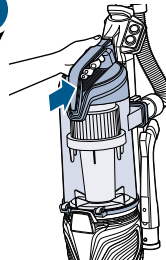

Place the Dirt Tank on the vacuum by securing the bottom in place first, then pushing back until you hear a “click”.

6

Install Optional Febreze Filter

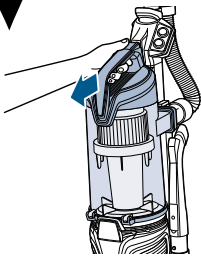

Press the Dirt Tank Release Button and pull away from vacuum.

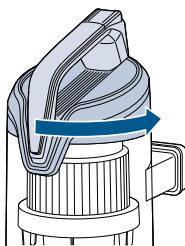

Twist tank cover to the unlock position then pull up on Handle.

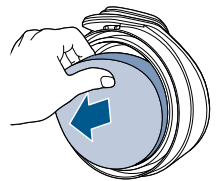

Remove the Pre-Motor Filter and replace with the Febreze Filter.

Certain trademarks used under license from The Procter & Gamble Company or its affiliates.

Thanks for buying a BISSELL® vacuum!

We love to clean and we're excited to share one of our innovative products with you. We want your vacuum to work like new for the years to come, so this guide has tips on how to use, maintain and, if there's a problem, troubleshoot.

Your vacuum needs a little assembly before getting to work, so flip to the "Assembly" section and let's get started!

What's in the Box?

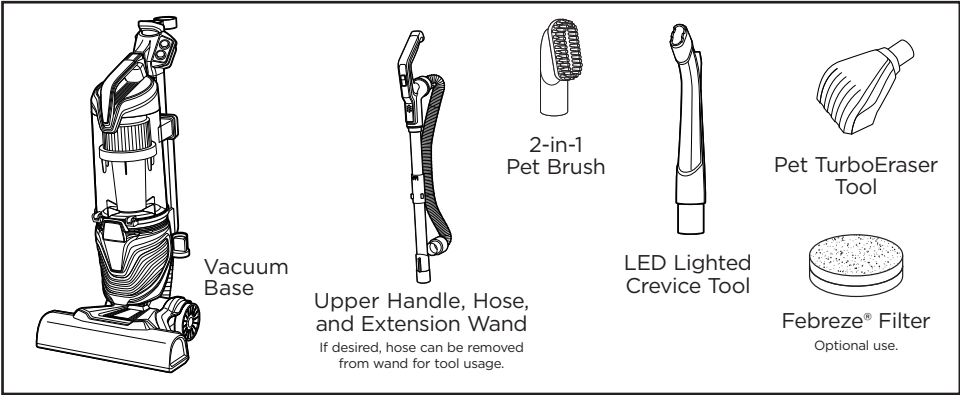

NOTE: Standard accessories may vary by model. To identify what should be included with your purchase, please refer to the "Carton Contents" list located on the carton top flap.

Quick Start / Assembly 3

Safety Instructions 2

Product View 5

Operations 6-7

Maintenance & Care 8-13

Troubleshooting 14

Warranty 15

Service 15

Product Registration 16

Parts & Supplies 16

Product View

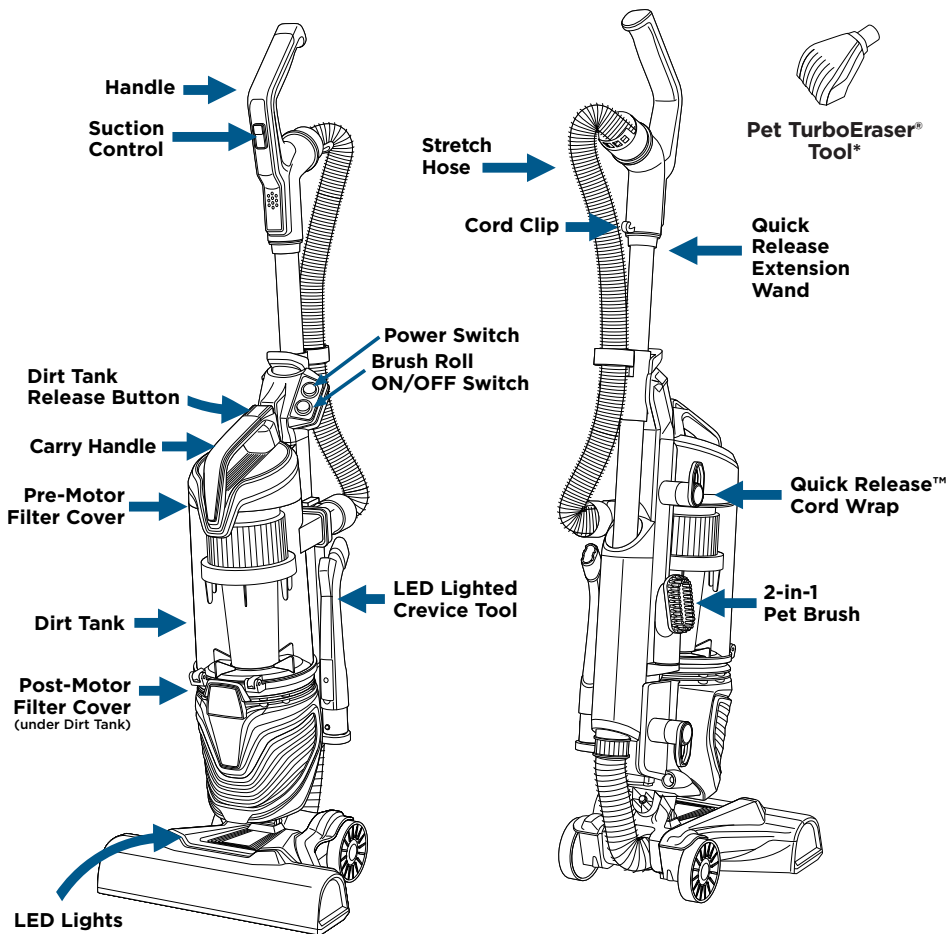

*NOTE: Pet TurboEraser® Tool does not store on unit.

THIS APPLIANCE HAS A POLARIZED PLUG

To reduce the risk of electric shock, this appliance has a polarized plug (one blade is wider than the other). This plug will fit in a polarized outlet only one way. If the plug does not fit fully in the outlet, reverse the plug. If it still does not fit, contact a qualified electrician to install a proper outlet. Do not change the plug in any way.

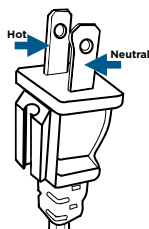

Operations

WARNING

Do not plug in your vacuum until you are familiar with all instructions and operating procedures.

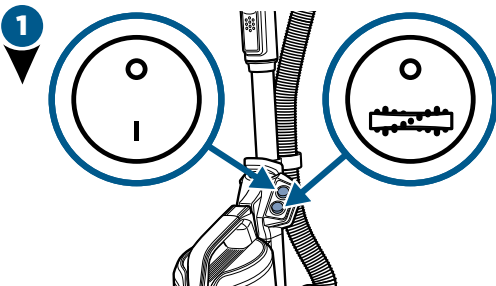

Turn vacuum ON by pressing Power Switch ON (I - ON and O - OFF). Press Brush Roll ON/OFF Switch to run the PowerBrush for carpet cleaning (Brush Roll is on when light on switch is illuminated). See page 13 to maintain the Brush Roll.



Step gently on base and pull back on Handle to recline.

NOTE: The Brush Roll will automatically shut off when vacuum is locked in upright position. Recline to reactivate.

NOTE: In the unlikely event that hair wrapped around your Brush Roll, run vacuum back and forth on clean carpet several times to help release any wrapped hair.

NOTE: Turn OFF the Brush Roll when vacuuming hard or delicate surfaces that may be caught by the rotating brush. This could include hard wood, tiled floors, small area rugs, or frieze carpets that have long delicate fibers or threads.

Adjusting the Suction Control

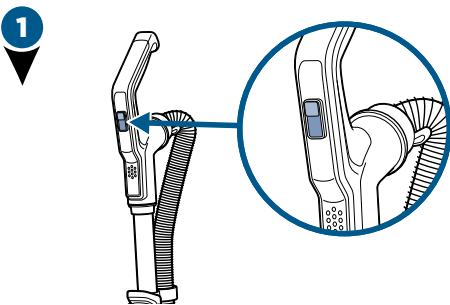

Locate the Suction Control setting on the vacuum Handle. Adjust Suction Control for plush carpet or low carpet for easy multi-surface cleaning.

Above-Floor Cleaning

1

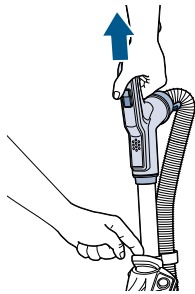

Clean hard to reach spaces with the Quick Release Extension Wand. Push the release button to remove and attach desired tool.

2

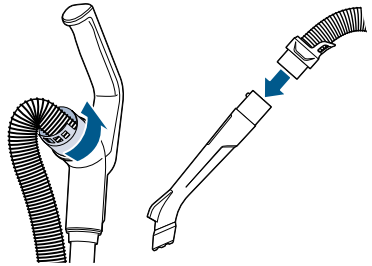

If desired, the Stretch Hose can be removed from the Extension Wand. To do so, twist hose from the back of the wand to remove.

3

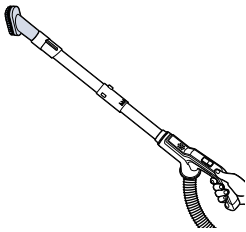

Attach desired tool. Use the Pet TurboEraser® Tool for best results on stairs. Or use the 2-in-1 Pet Brush with soft, white bristles for sensitive/gentle surfaces and rubber nubs to pick up embedded pet hair.

4

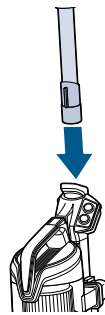

When finished, replace the wand back on the vacuum by sliding into place until you hear “click”.

Vacuum Motor Protection

An internal thermal protector has been designed into your vacuum to protect it from overheating. When the thermal protector activates, the main vacuum motor will stop operating. The front lights will remain on, even though the motor turns OFF. If this happens, proceed as follows.

- 1** Turn vacuum OFF and unplug from electrical outlet.
- 2** Check for the source of overheating problem (full Dirt Tank, dirty filters, or a clog) and fix by following the maintenance instructions.
- 3** When the motor cools for approximately 30 minutes, the thermal protector automatically resets and cleaning may continue. If the vacuum will not turn ON or the thermal protector continues to activate, your vacuum may need servicing. Contact BISSELL Consumer Care.

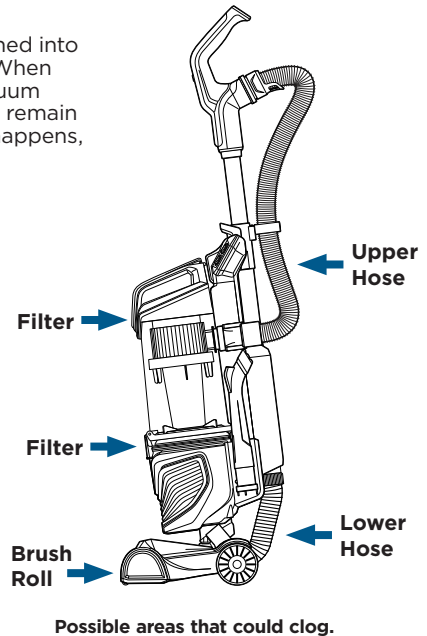

NOTE: The thermal protector controls the main vacuum motor only, not the brush motor. If the thermal protector activates, brush and lights will continue to operate normally; however, there will be no suction.

Remove/Empty Dirt Tank

⚠️ WARNING

To reduce the risk of electrical shock, turn Power Switch OFF and disconnect polarized plug from electrical outlet before performing maintenance or troubleshooting checks.

1

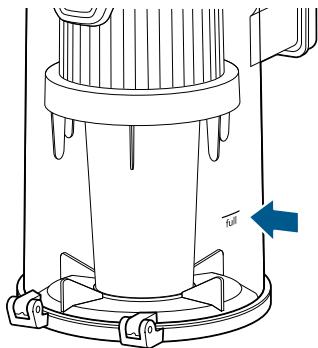

The Dirt Tank is full. Time to empty!

2

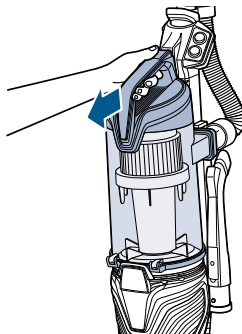

Press the Tank Release Button and grab the Handle to pull the Dirt Tank away from vacuum.

3

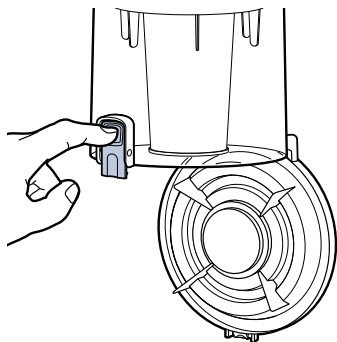

Hold the Dirt Tank over a trash bin and press the Empty Button. Once emptied, snap bottom back into place.

4

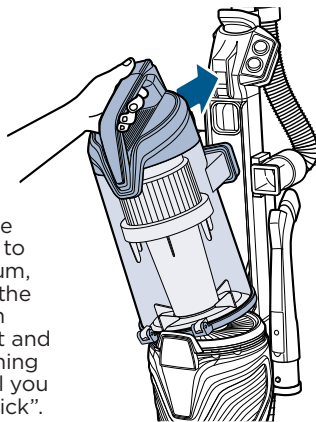

Return the Dirt Tank to the vacuum, securing the bottom in place first and then pushing back until you hear a "click".

⚠️ WARNING

Do not operate vacuum with damp or wet filters. Allow components to dry before reassembling the Dirt Tank.

⚠️ WARNING

Before using your vacuum, make sure that the Dirt Tank is in locked position and that all filters, both pre- and post-filters, are in place. DO NOT operate your vacuum without these filters.

Clean/Replace Pre-Motor Filters

WARNING

To reduce the risk of electrical shock, turn Power Switch OFF and disconnect polarized plug from electrical outlet before performing maintenance or troubleshooting checks.

WARNING

Do not operate vacuum with damp or wet filters. Allow components to dry before reassembling the Dirt Tank.

1

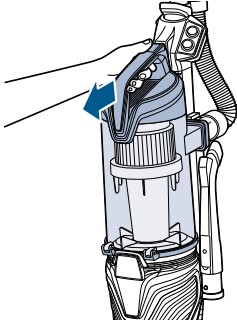

Press the Dirt Tank Release Button and pull away from vacuum.

2

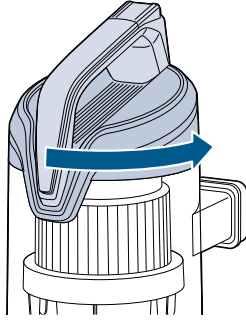

Twist tank cover to the unlock position then pull up on Handle.

3

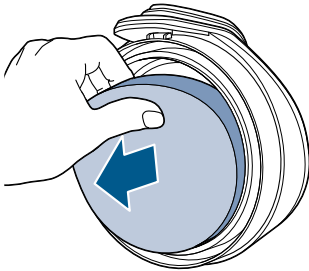

Remove Pre-Motor Filter from top of Dirt Tank lid by pulling out.

4

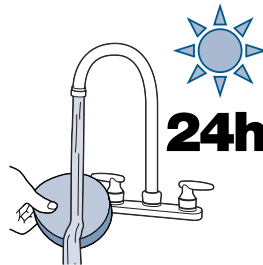

Both Pre-Motor Felt and Foam Filters are washable. Clean with mild detergent, rinse and squeeze all excess water. Allow filters to dry completely before reinserting. Return Pre-Motor Filters to the top of the Dirt Tank, placing the thick Foam Filter in last.

NOTE: Replace filters every 3 to 6 months. Visit BISSELL.com for filter replacements.

NOTE: Washing may decrease the Febreze odor eliminating scent.

Certain trademarks used under license from The Procter & Gamble Company or its affiliates.

Clean/Replace Post-Motor Filter

WARNING

To reduce the risk of electrical shock, turn Power Switch OFF and disconnect polarized plug from electrical outlet before performing maintenance or troubleshooting checks.

WARNING

Do not operate vacuum with damp or wet filters. Allow components to dry before reassembling the Dirt Tank.

1

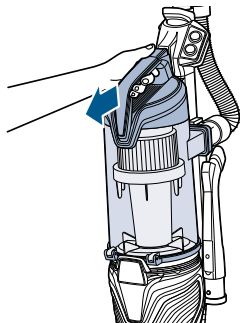

Press the Dirt Tank Release Button and pull Dirt Tank away from vacuum.

2

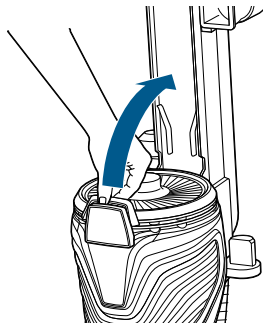

Pull tab up to access Post-Motor Filter.

3

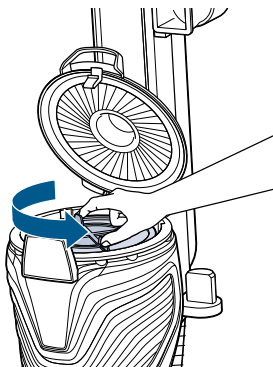

Twist filter counter-clockwise to unlock and remove from vacuum.

4

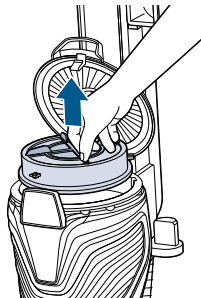

When reassembling, be sure to lock the filter back into place. The pleated filter may NOT be washed. If dust/debris accumulates, gently tap the filter on the inside of a trash container.

NOTE: Replace filters every 3 to 6 months. Visit BISSELL.com for filter replacements.

Clean Inner Cyclone Separator

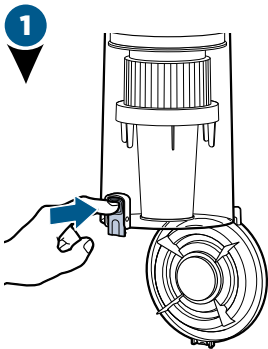

1
Hold the Dirt Tank over a trash container. Press the bottom release button to empty.

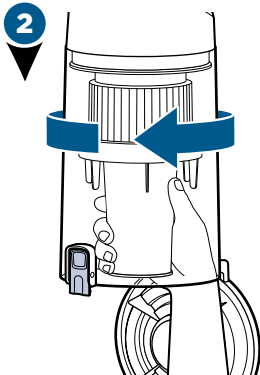

2
Twist Cyclone counter-clockwise and pull down to remove from tank.

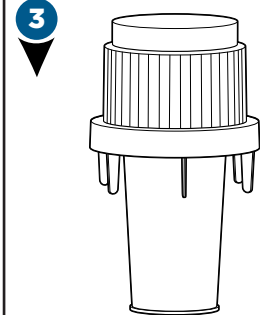

3
Tap separator against inside of trash container and rinse under warm water, if necessary. Be sure to let it dry completely before placing back in Dirt Tank.

Maintain Pet TurboEraser® Tool

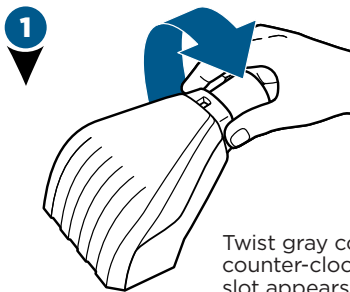

1
Twist gray collar counter-clockwise, until slot appears, and then separate faceplate.

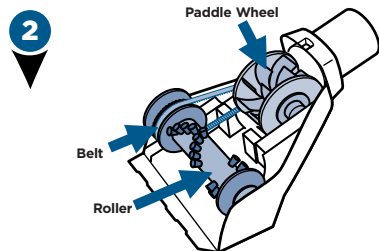

2
Remove Brush Roll, Belt, and Paddle Wheel. Inspect for damages and replace if necessary.

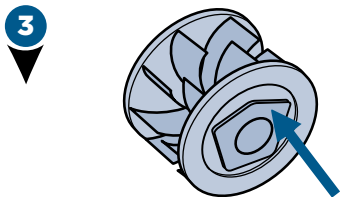

3
To reassemble, align two clips on each end of Paddle Wheel with Belt on and pop back into place. Place Brush Roll with Belt back in. Faceplate will not close properly if all parts are not aligned correctly.

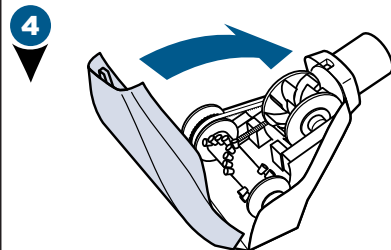

4
To put faceplate back on, align the tabs in the top of the cover and place it down to "click" into place.

Replace Brush and Belt

1

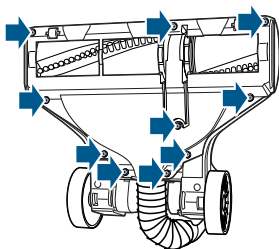

Unplug and turn vacuum over. Unscrew 10 Phillips-head screws to remove bottom cover.

2

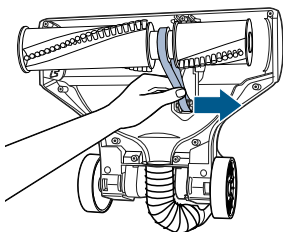

Pull Brush Roll straight out and slide Belt off motor gear. Replace Brush Roll and/or Belt.

3

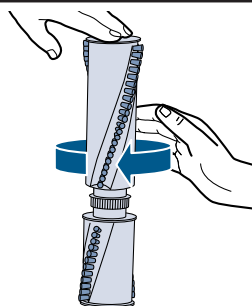

Inspect Brush Roll by placing it on its end and spinning. The Brush Roll should spin freely, multiple times by one flick. If it doesn't, replace Brush Roll. Inspect Belt, replace if it appears damaged.

4

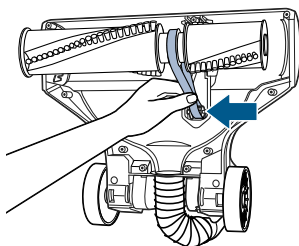

1. Place Belt back on Brush Roll.
2. Pinch Belt around Brush Roll & hook back around the motor gear.

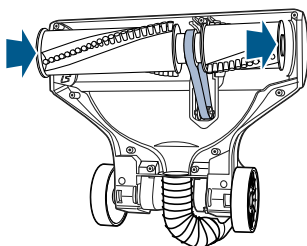

3. Rotate Brush Roll into place and line up end caps.
4. Re-attach bottom cover with 10 screws.

NOTE: If an object becomes lodged in foot and brush shuts OFF, turn vacuum OFF and unplug from electrical outlet. Remove obstruction and brush will automatically reset when vacuum is plugged and turned back ON.

Parts & Supplies

For Parts and Supplies, go to www.BISSELL.com and enter your model number in the search field.

Troubleshooting

WARNING

To reduce the risk of electric shock, turn Power Switch OFF and disconnect plug from electrical outlet before performing maintenance or troubleshooting checks.

Problem	Possible causes	Remedies
Brush Roll doesn't rotate	Brush Roll switch is turned OFF.	Make sure Brush Roll switch is ON.
	Vacuum is locked in upright position.	Recline vacuum and switch ON the Brush Roll.
	Vacuumping on Premium Soft Carpet.	Adjust Suction Control to reduce suction on softer carpets.
	Brush Roll has lodged debris or other entanglements, keeping the brush from rotating.	Unplug to reset brush motor, checking for and removing debris before turning ON.
Vacuum won't pick up dirt	Filters are dirty.	Remove and rinse Pre-Motor Filters. Allow enough time for them to dry properly before reinserting. Remove and dust off Post-Motor Filter.
	There is a clog in the vacuum.	Remove bottom cover and check for any buildup of debris. Remove debris and debris buildup before reinstalling bottom cover.
	Dirt Tank is not seated correctly.	Press the Tank Release to release the Dirt Tank and reseal properly.
	There is a crack or hole in the Main Hose.	If there is a crack or hole, order a new Main Hose from the BISSELL website.
	Main Hose is not connected.	Locate the hose and reconnect by pushing the hose connection.
	There is a clog in the hose.	Disconnect Lower Hose and check for clogs as well. Use a broom handle to push any debris out.
	Hair wrapped around Brush Roll.	Run vacuum back and forth on clean carpet several times to release wrapped hair.
Dirt is escaping from the vacuum	Dirt Tank is full.	Empty the Dirt Tank.
	Filters are missing or dirty.	Check to see if all of the Pre-Motor and Post-Motor Filters are in place and clean.
Hose won't pick up dirt	Suction is set too low.	Adjust using the Suction Control Feature.
Vacuum is hard to push or pull	Suction is set too high.	Adjust using the Suction Control Feature.
High-pitched noise	There is a clog in the vacuum.	Check inside of Main Hose and Lower Hose for clogs by disconnecting from vacuums.

Warranty

This warranty gives you specific legal rights, and you may also have other rights which may vary from state to state. If you need additional instruction regarding this warranty or have questions regarding what it may cover, please contact BISSELL Consumer Care by E-mail or telephone as described below.

It may be necessary to obtain some of your personal information, such as a mailing address, to fulfill terms of this warranty. Any personal data will be handled pursuant to BISSELL's Privacy Policy, which can be found online at www.BISSELL.com/privacy-policy.

Limited Three-Year Warranty

Subject to the ***Exceptions and Exclusions from the Terms of the Limited Warranty**, upon receipt of the product BISSELL will repair or replace (with new, refurbished, lightly used, or remanufactured components or products), at BISSELL's option, free of charge from the date of purchase by the original purchaser, for three years, any defective or malfunctioning part.

See information below on "If your BISSELL product should require service".

This warranty applies to product used for personal, and not commercial or rental, service. This warranty does not apply to fans or routine maintenance components

such as filters, belts or brushes. Damage or malfunction caused by negligence, abuse, neglect, unauthorized repair, or any other use not in accordance with the user guide is not covered. This warranty will only be valid if the product is used in the same country in which it was sold.

BISSELL is not liable for incidental or consequential damages of any nature associated with the use of this product. BISSELL's liability will not exceed the purchase price of the product.

Some states do not allow the exclusion or limitation of incidental or consequential damages, so the above limitation or exclusion may not apply to you.

*Exceptions and Exclusions from the Terms of the Limited Warranty

This warranty is exclusive and in lieu of any other warranties, either oral or written. Any implied warranties, which may arise by operation of law, including the implied warranties of merchantability and fitness for a particular purpose, are limited to the three-year duration from the date of purchase as described above.

Some states do not allow limitations on how long an implied warranty lasts, so the above limitation may not apply to you.

NOTE: Please keep your original sales receipt. It provides proof of date of purchase in the event of a warranty claim.

Service

Please do not return this product to the store.

Other maintenance or service not included in the manual should be performed by an authorized service representative.

If your BISSELL® product should require service:

Contact BISSELL Consumer Care to locate a BISSELL Authorized Service Center in your area. If you need information about repairs or replacement parts, or if you have questions about your warranty, contact BISSELL Consumer Care.

Website:

www.BISSELL.com/service-centers

E-mail:

www.BISSELL.com/email-us

Call:

BISSELL Consumer Care

1-800-237-7691

Monday – Friday: 8am - 10pm ET

Saturday: 9am - 8pm ET

Sunday: 10am - 7pm ET

Register your product today!

Registering is quick, easy and offers you benefits over the lifetime of your product.

You'll receive:

BISSELL® Rewards Points

Automatically earn points for discounts and free shipping on future purchases.

Faster Service

Supplying your information now saves you time should you need to contact us with questions regarding your product.

Product Support Reminders and Alerts

We'll contact you with any important product maintenance reminders and alerts.

Special Promotions

Optional: Register your email to receive notice of offers, contests, cleaning tips, and more!

Visit www.BISSELL.com/registration!

Visit the BISSELL website: www.BISSELL.com

When contacting BISSELL, have model number of cleaner available.

Please record your Model Number: _____

Please record your Purchase Date: _____

NOTE: Please keep your original sales receipt. It provides proof of purchase date in the event of a warranty claim. See Warranty page for details.

Parts & Supplies

For Parts and Supplies, go to www.BISSELL.com and enter your model number in the search field.

*Love your **BISSELL®** product?*

Don't keep it a secret.

Let us, and millions of others, know what you think!

Leave your star-rating on BISSELL.com

www.BISSELL.com



©2019 BISSELL Inc.
All rights reserved. Printed in China.
Part Number 162-0937 05/19 RevA
Visit our website at: www.BISSELL.com