

Instant^{TM/MC}

VORTEXTM PLUS

10 Quart Air Fryer Oven



User Manual

- Welcome
- Important Safeguards
- Product Specifications
- Initial Setup
- Product, Parts and Accessories
- Control Panel
- Initial Test Run
- Smart Programs
- Rotisserie Cooking
- Cooking Timetable
- Care and Cleaning
- Troubleshooting
- Warranty
- Contact Information

Welcome to the world of Instant cooking.

Thank you for welcoming us into your kitchen.

Having families ourselves, we developed the Instant™ Vortex™ Plus air fryer oven to allow busy families and professionals alike to cook healthy, delicious meals more easily and in less time.

We have partnered with chefs, authors and bloggers to compile a collection of recipes that we hope you enjoy!

Happy cooking,



Robert J. Wang
Founder and Chief Innovation Officer



Download the Instant Pot App

- Original Recipes
- New User Tips
- Getting Started Videos



Find helpful [how-to videos](#), [download the app](#), or visit our [recipe](#) site.

Table of Contents

IMPORTANT SAFEGUARDS	4
Special Cord Set Instructions	7
Product Specifications.....	7
Initial Setup	8
Product, Parts and Accessories	9
Control Panel	11
More Controls	12
Display Messages	13
Initial Test Run	14
Smart Programs	16
Using the Rotisserie Accessories	17
To use the Rotisserie Spit and Forks.....	18
To use the Rotisserie Spit and Basket.....	20
Removing the Accessory	23
Cooking Timetable	24
Cooking Tips	25
Care and Cleaning	26
Remove the Oven Door.....	27
Reinstall the Oven Door	27
Troubleshooting	28
Warranty	29
Contact Information	31

IMPORTANT SAFEGUARDS

When using electrical appliances, basic safety precautions should always be followed:

1. READ THE *GETTING STARTED GUIDE* AND ALL INSTRUCTIONS, SAFEGUARDS, AND WARNINGS BEFORE OPERATING THE APPLIANCE. FAILURE TO FOLLOW THESE SAFEGUARDS AND INSTRUCTIONS MAY RESULT IN INJURY AND/OR PROPERTY DAMAGE.
2. Always operate the appliance on a stable, non-combustible, level surface.
3. The appliance's outer surfaces may become hot during use. Do not touch hot surfaces. Wear proper hand protection when opening the oven door and handling hot components. Extreme caution must be used when moving the appliance. Let the appliance cool to room temperature before handling or moving.
4.  To protect against the risk of electrical shock, do not immerse power cord, plug, or the appliance in water or other liquid.
5. Do not rinse the appliance under tap.
6. The cooking chamber contains electrical components. To avoid electrical shock, do not put liquid of any kind into the cooking chamber.
7. This appliance is NOT to be used by children or by persons with reduced physical, sensory, or mental capabilities. Close supervision is necessary when this appliance is used near children and these individuals. Children should not use or play with this appliance.
8. Unplug from the outlet when not in use, as well as before adding or removing parts or accessories, and before cleaning. To unplug, grasp the plug and pull from the outlet. Never pull from the power cord.
9. Avoid contact with moving parts.
10. Regularly inspect the appliance and power cord. Do not operate any appliance with a damaged cord or plug or after the appliance malfunctions, or is dropped or damaged in any manner. Contact Customer Care at support@instantappliances.com or **1-800-828-7280**.
11. Do not use any accessories or attachments not authorized by Instant Brands Inc. The use of attachments not recommended by the manufacturer, such as fry baskets, may cause a risk of injury, fire or electric shock.
12. For household countertop use only. Do not use outdoors. Not for commercial use.



Read this manual carefully and completely, and retain for future reference. Failure to adhere to safety instructions may result in serious injury.

IMPORTANT SAFEGUARDS

13. Do not place the appliance on any kind of stovetop, or in a heated oven. Heat from an external source will damage the appliance.
14. Do not let power cord contact hot surfaces or open flame, including a stovetop.
15. Do not use appliance for anything other than intended use.
16. Proper maintenance is recommended after each use. Refer to [Care and Cleaning](#). Let the appliance cool to room temperature before cleaning or storage.
17. **⚠ CAUTION** Spilled food can cause serious burns. A short power supply cord is provided to reduce the hazards resulting from grabbing, entanglement and tripping. Keep appliance and cord away from children. Never drape cord over edge of table or counter, never use power outlet below counter, and never use with an extension cord.
18. Do not attempt to repair, replace, alter, or modify components of the appliance. This may cause electric shock, fire and/or injury, and will void the warranty.
19. Do not tamper with any of the safety mechanisms.
20. Do not use the appliance in electrical systems other than 120V / 60Hz for Canada and the USA. Do not use with power converters or adapters.
21. Do not overfill the air fryer basket. Overfilling may cause food to contact the heating element, which may result in fire and/or personal injury.
22. Do not cover the air vents while the appliance is in operation. Doing so will prevent even cooking and may cause damage to the appliance.
23. Never pour oil into the cooking chamber. Fire and personal injury could result.
24. While cooking, the internal temperature of the appliance reaches several hundred degrees. To avoid personal injury, never place unprotected hands inside the appliance until it has cooled to room temperature.
25. When cooking, do not place the appliance against a wall or against other appliances. Leave at least 5" / 13 cm of free space on the back, sides, and above the appliance. Do not operate the appliance on or near combustible materials such as tablecloths and curtains. Do not place anything on top of the appliance.



Read this manual carefully and completely, and retain for future reference. Failure to adhere to safety instructions may result in serious injury.

IMPORTANT SAFEGUARDS

26. When in operation, hot air is released through the air vents. Keep your hands and face at a safe distance from the air vents and take extreme caution when removing the accessories from the appliance.
27. Should the unit emit black smoke, press **Cancel** and unplug the appliance immediately. Wait for smoking to stop before opening the door, then clean the appliance thoroughly.
28. Do not leave the appliance unattended while in use.
29. Never connect this appliance to an external timer switch or separate remote-control system.
30. Use extreme caution when removing hot accessories from the cooking chamber or disposing of hot grease.
31. Oversized foods and/or metal utensils must not be inserted into the cooking chamber as they may cause risk of fire and/or personal injury.
32. Do not store any materials, other than the included accessories, in the cooking chamber when not in use.
33. Do not place any combustible materials in the cooking chamber, such as paper, cardboard, plastic, Styrofoam or wood.
34. The included accessories are not to be used in a microwave, toaster oven, convection or conventional oven, nor on a ceramic, electric, induction or gas cooktop, or an outdoor grill.

SAVE THESE INSTRUCTIONS



Read this manual carefully and completely, and retain for future reference. Failure to adhere to safety instructions may result in serious injury.

IMPORTANT SAFEGUARDS

WARNING

To avoid injury, read and understand instruction manual before using this machine.

WARNING

Electrical shock hazard. Use grounded outlet only. DO NOT remove ground. DO NOT use an adapter. DO NOT use an extension cord. Failure to follow instructions can cause electrical shock and/or death.

WARNING

THE FAILURE TO FOLLOW ANY OF THE IMPORTANT SAFEGUARDS AND THE IMPORTANT INSTRUCTIONS FOR SAFE USE IS A MISUSE OF YOUR APPLIANCE THAT CAN VOID YOUR WARRANTY AND CREATE THE RISK OF SERIOUS INJURY.

Special Cord Set Instructions

Per safety requirement, a short power supply cord (0.6 m to 0.9 m / 24" to 35") is provided to reduce the hazards resulting from grabbing, entanglement and tripping.

This appliance has a 3-prong grounding plug. To reduce the risk of electric shock, plug the power cord into a grounded (earthed) electrical outlet that is easily accessible.

Product Specifications



Model:
Vortex Plus 10



10 Quart



120 V ~ 60 Hz



1500 W



16.94 lbs
7.7 kg

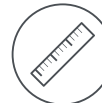

in: 13.23L x 13.23W x 14.37H
cm: 33.6L x 33.6W x 36.5H

The models listed may not represent all models in the Vortex, Vortex Plus, or Vortex Pro series. Visit instantappliances.com for details.

WARNING

Read this manual carefully and completely, and retain for future reference. Failure to adhere to safety instructions may result in serious injury.

Initial Setup

- Read all the [Important Safeguards](#) before using the appliance. Failure to read and follow the Important Safeguards may result in damage to the appliance, property damage or personal injury.
- Remove all packaging material and accessories from within and around the appliance.
- Place the appliance on a stable, level surface, away from combustible material and external heat sources.
- Leave at least 5" / 13 cm of space above and around all sides of the appliance.
- Do not place anything on top of the oven and do not block the air vents.
- Remove the [accessories](#) and check the cooking chamber for loose packing material before first use.
- Follow [Care and Cleaning](#) instructions in this manual to clean the appliance before first use.

⚠ CAUTION

Do not place the appliance on a stove top. Heat from an external source will damage the appliance. Do not place anything on top of the appliance, and do not block the air vents.

Product, Parts and Accessories

Before using the air fryer oven, verify that all parts and accessories are accounted for.

Air Fryer Oven 10 Quart

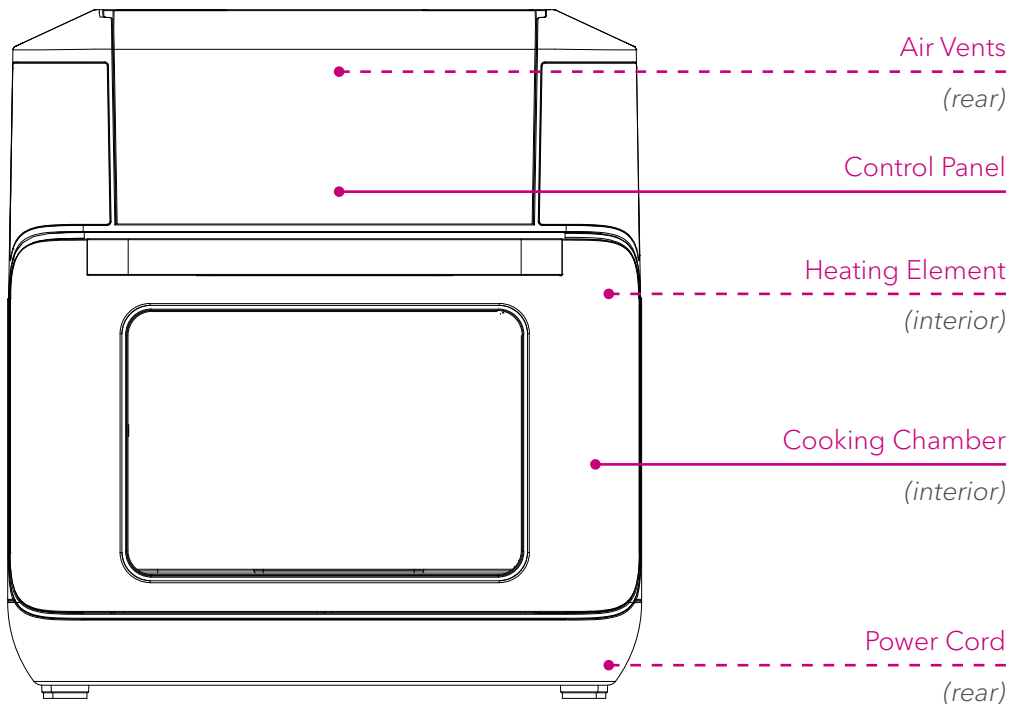

Illustrations are for reference only and may differ from the actual product.

Product, Parts and Accessories

Accessories

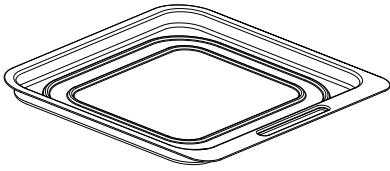

Drip Pan

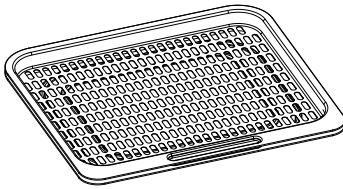

Cooking Tray (x2)

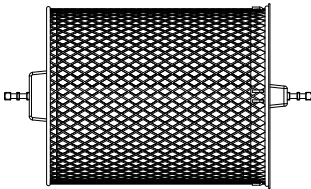

Rotisserie Basket

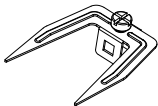

Rotisserie Fork (x2)

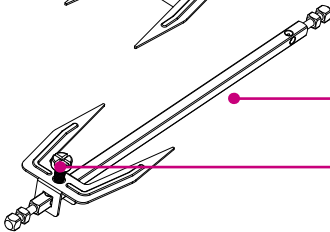

Rotisserie Spit

Setting Screw (x2)

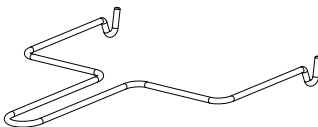

Rotisserie Lift

Illustrations are for reference only and may differ from the actual product.

Control Panel

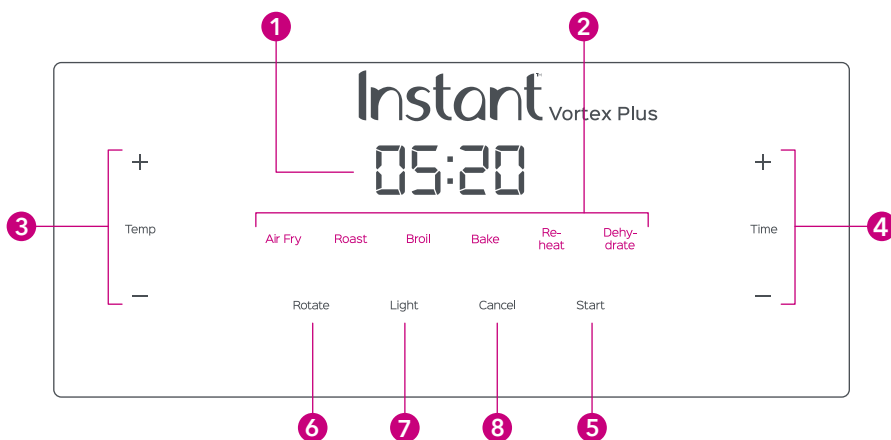

1 Display

Indicates cooking time, cooking temperature, reminders and error messages. Display reads **OFF** when the oven is in Standby mode.

2 Smart Programs

Smart Programs control cooking times and temperatures automatically. Select a Smart Program by touching the label on the control panel. The key flashes to indicate that it has been selected.

Vortex Plus 10 Smart Programs:

- Air Fry
- Roast
- Broil
- Bake
- Reheat
- Dehydrate

Note: Each Smart Program includes a default cooking time and temperature.

3 Adjust Temperature

Touch the **Temp +** or **-** keys to adjust the cooking temperature. Touch and hold to adjust quickly.

4 Adjust Time

Touch the **Time +** or **-** keys to adjust the cooking time. Touch and hold to adjust quickly.

Note: Smart Programs save your time and temperature adjustments when you touch **Start**.

5 Start

Touch **Start** to begin cooking.

6 Rotate

Once cooking has begun, touch the **Rotate** button to turn rotisserie rotation on and off.

Note: Applicable to **Air Fry** and **Roast** only. The button turns white when the Rotate function is running and Blue when it's off.

7 Light

Touch **Light** to turn the oven light on or off. The oven light turns off automatically after 2 minutes.

8 Cancel

Touch **Cancel** to stop cooking. The oven goes into Standby mode and the display reads **OFF**.

Smart Program Settings

Sound On/Off

When in Standby (display indicates **OFF**), touch and hold both the **Temp** and **Time** minus (**-**) keys for 3 seconds to toggle sound on or off.

Note: Error alerts cannot be silenced.

Reset Individual Smart Programs

When in Standby, touch and hold the Smart Program you wish to reset for 3 seconds. The Smart Program's cooking time and cooking temperature are restored to the default setting.

Reset All Smart Programs

When in Standby, touch and hold both the **Temp** and **Time** plus (**+**) keys for 3 seconds. All Smart Program cooking times and cooking temperatures are restored to the default settings.

Display Messages

OFF

Indicates that the air fryer oven is in Standby mode.

On

Indicates that the air fryer oven has begun **pre-heating**.

Add
Food

Indicates that the air fryer oven has reached the desired temperature and food may be added.

00:00

The timer counts down to indicate that a Smart Program is running.

Turn
Food

A reminder to turn, flip or shake food items, as recommended by your recipe.

End

Indicates that the Smart Program has ended.

Initial Test Run

Follow these steps to ensure your air fryer oven is operating properly.

Approximate time: 25 minutes

1. Open the oven door.
Place the drip pan on the bottom of the cooking chamber.
Close the oven door.
2. Connect the power cord to a 120 V power source.
The display reads **OFF** to indicate that the oven is in Standby mode.
3. Touch **Air Fry** on the control panel to select it.
The default cooking time is **18** minutes.
The default cooking temperature for Air Fry is **400°F**.
4. Use the **+** or **- Time** keys to adjust the cook time to **00:20** minutes.
Note: *Smart Programs automatically save your last temperature and time settings.*
5. Touch **Start** to begin cooking.
The display indicates **On** while the cooker preheats, as well as the cooking status: **Preheat**.
Note: *Use the **+** or **-** keys for **Temp** or **Time** to adjust the cook time and temperature at any time.*
6. When the oven reaches the target temperature, the display indicates **Add Food**.
For this initial test run, do not add food to the cooking chamber.
Note: *The air fryer oven should be preheated before adding food items, except when using the rotisserie setting. The cooking cycle will commence after 10 seconds whether food has been added or not.*
7. Open the oven door.
Use proper hand protection to carefully insert both cooking trays into the preheated cooking chamber.
Close the oven door.
The display indicates the cooking time and temperature, as well as the cooking status: **Cook**.

Initial Test Run

- Part way through the Smart Program, the oven beeps and displays **turn Food** to remind you to flip your food items. When cooking with both cooking trays, swap their positions in the cooking chamber.
Open the glass door to automatically pause the Smart Program, then close the door to resume.
*Note: The **turn Food** notice only appears when using **Air Fry** and **Roast** Smart Programs. If **Rotate** is turned on, the message will not appear. Some food items do not need to be turned. Cooking will resume after 10 seconds whether food has been turned or not.*
- The display counts down the last minute of cooking time in seconds. When the Smart Program ends, the display indicates **End**.
Note: If the door is not opened, the oven will remind you that food is ready 5, 30, and 60 minutes after the Smart Program ends.

Follow these basic steps to cook with any Smart Program in the air fryer oven.

CAUTION

The oven will be hot during and after cooking. Do not touch hot surfaces. Always use proper hand protection to remove cooking trays. Allow the oven to cool to room temperature, then clean the accessories and cooking chamber. Refer to [Care and Cleaning](#) in this user manual.

Smart Programs

The Vortex Plus air fryer oven uses rapid air circulation to cook food, giving your meals all the rich, crispy flavor of deep frying with little or no oil.

Smart Program	Default Time	Time Range	Default Temperature	Temperature Range
Air Fry	18 minutes	1 - 60 minutes	400°F / 205°C	180 - 400°F / 82 - 205°C
	For all your favorite deep-fried meals, including fries, cauliflower wings, chicken nuggets and more.			
Roast	40 minutes	1 - 60 minutes	380°F / 193°C	180 - 400°F / 82 - 205°C
	Ideal for beef, lamb, pork, poultry, vegetable dishes and more.			
Broil	8 minutes	1 - 20 minutes	400°F / 205°C	400°F / 205°C
	Direct top-down heating. Perfect for melting cheese on French onion soup, nachos and more.			
Bake	30 minutes	1 - 60 minutes	365°F / 185°C	180 - 400°F / 82 - 205°C
	Light and fluffy cakes and pastries, scalloped potatoes and more.			
Reheat	10 minutes	1 - 60 minutes	280°F / 138°C	120 - 360°F / 49 - 182°C
	Reheat leftovers without overcooking or drying out.			
Dehydrate	7 hours	1 - 15 hours	120°F / 49°C	105 - 160°F / 41 - 71°C
	Perfect for homemade fruit leather, jerky, dried vegetables and more.			

CAUTION

Use a meat thermometer to ensure meat reaches a safe minimum internal temperature. Refer to the USDA's [Safe Minimum Internal Temperature Chart](#) for more information.

Using the Rotisserie Accessories

The Instant Vortex Plus is equipped with One-Step Even Crisp Technology™ for simple rotisserie-style cooking with delicious results.

Always insert rotisserie accessories and food items into the cooking chamber before preheating the air fryer oven.

To use the Rotisserie Basket

Read these instructions and/or watch the [tutorial video](#) to ensure you are using the rotisserie properly. Failure to follow these steps could result in damage to the rotisserie catch.

- 1 Place food items in the rotisserie basket. Do not overfill the rotisserie basket.

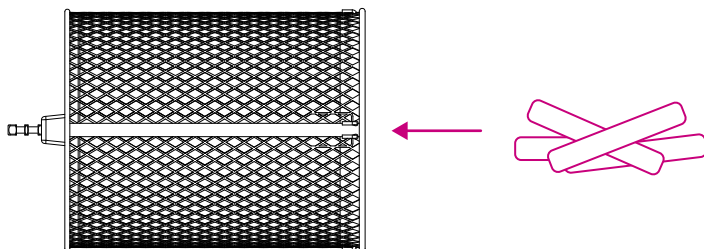

- 2 Align the tab on the rotisserie basket with the notch in the lid, then place the lid on the basket.

- 3 Turn the lid clockwise to secure it.

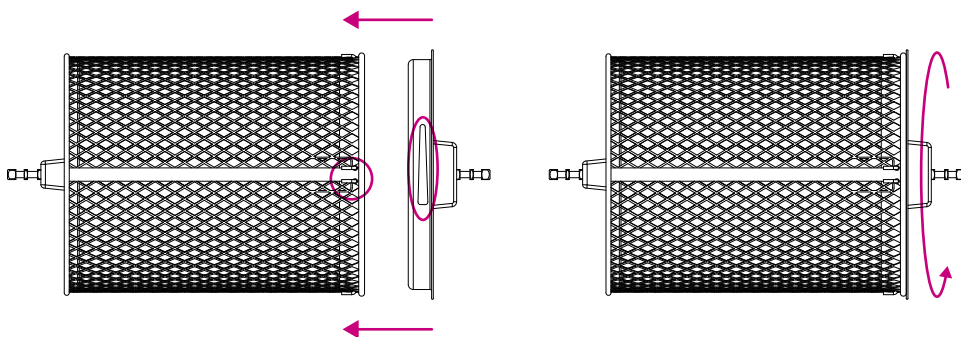

Using the Rotisserie Accessories

Always insert rotisserie accessories and food items into the cooking chamber **before** preheating the air fryer oven.

To use the Rotisserie Spit and Forks

- 1 Unscrew the 2 setting screws.

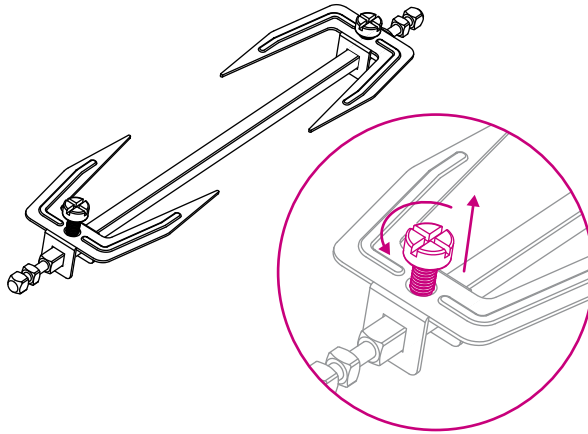

- 2 Remove the forks from the spit.

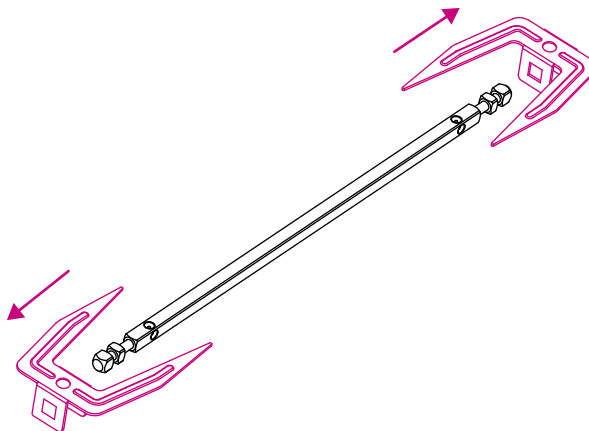

Using the Rotisserie Accessories

- 3** Push the food item onto the spit.

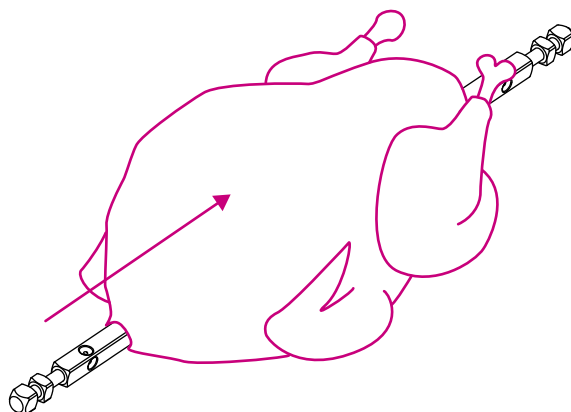

- 4** Slide the forks onto both ends of the spit, ensuring the prongs are inserted into the food item.

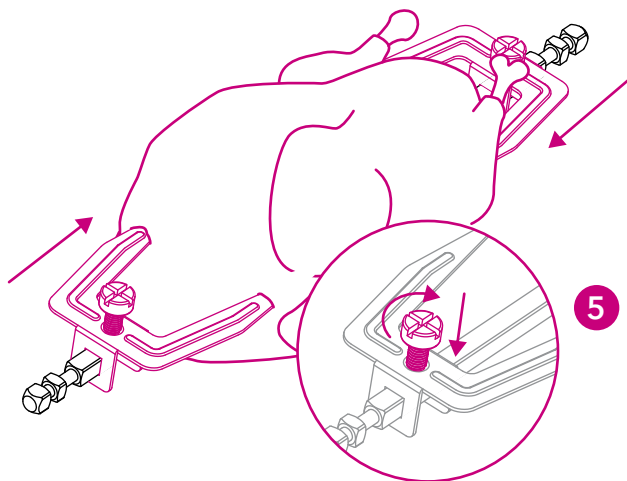

- 5** Tighten the setting screws to secure the forks.

CAUTION

Ensure the food item is able to rotate freely in the cooking chamber. Do not allow food items to make contact with the heating coil.

Using the Rotisserie Accessories

Always insert rotisserie accessories and food items into the cooking chamber before preheating the air fryer oven.

To use the Rotisserie Spit or Basket

Read these instructions and/or watch the [video](#) to ensure you are using the rotisserie properly. Failure to follow these steps could result in damage to the rotisserie catch.

- 1 Open the oven door and slide the rotisserie basket or rotisserie spit onto the guides in the cooking chamber.

Note: The rotisserie basket and rotisserie spit are installed and removed the same way.

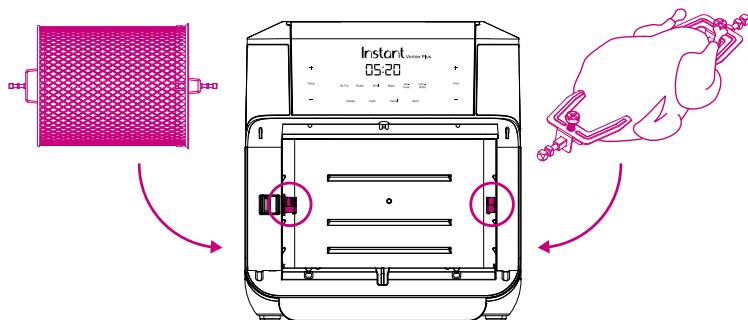

- 2 Move the rotisserie catch lever to the right and hold it in position.

Notice that the rotisserie catch inside the cooking chamber withdraws slightly when you move the lever.

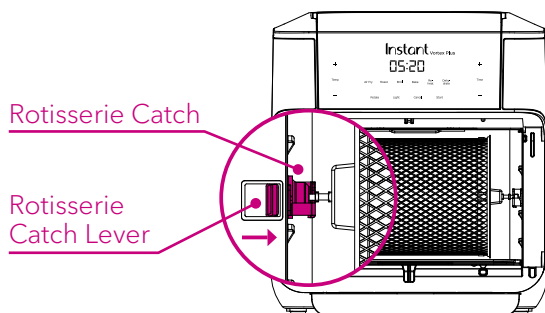

Using the Rotisserie Accessories

- 3** Align the rotisserie spit with the hole in the rotisserie catch, and set the other end of the rotisserie spit in the notch on the right of the cooking chamber.

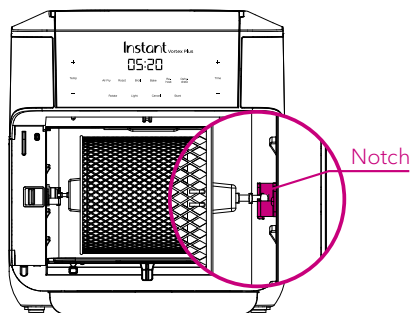

- 4** Release the rotisserie catch lever. Rotate the accessory in place to ensure that it is held securely.

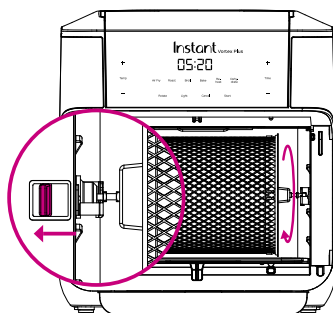

- 5** Close the oven door.

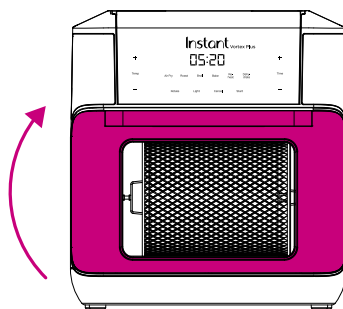

Using the Rotisserie Accessories

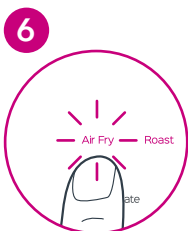
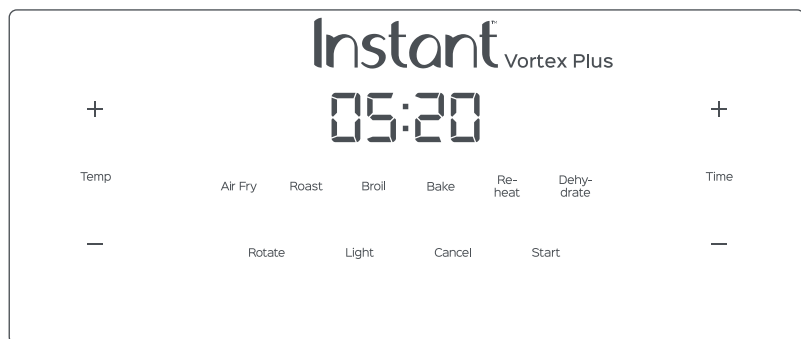

Select **Air Fry** or **Roast**.

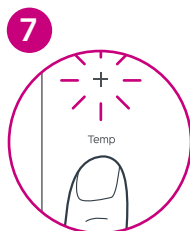

Touch the **+** or **- Temp** and **Time** keys to adjust cooking temperature and time as desired.

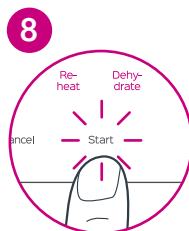

Touch **Start**.

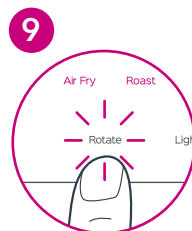

Touch **Rotate**.

Removing the Accessory

Use caution when opening the oven door. The oven door and accessories will be hot.

- 1 Position the rotisserie lift hooks beneath the left and right arms of the accessory.

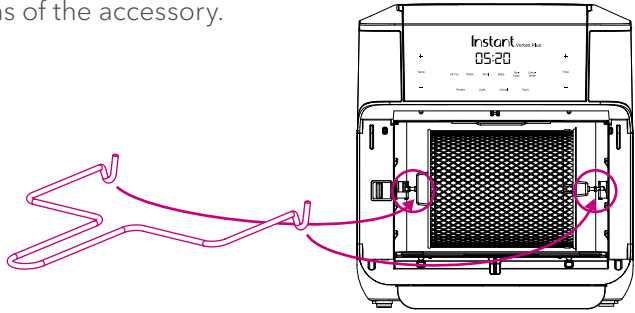

- 2 Move the rotisserie catch lever to the right to release the accessory.

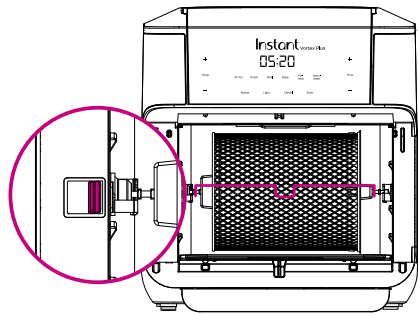

- 3 Pull the accessory towards you, then release the rotisserie catch lever.

- 4 Carefully remove the accessory from the cooking chamber.

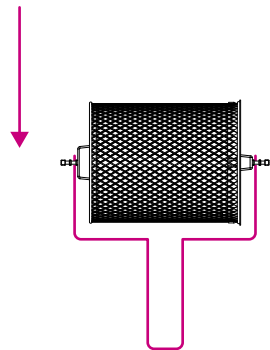

⚠️ WARNING

Rotisserie spit, forks, and basket will be hot during and after cooking. Always use the rotisserie lift to remove rotisserie accessories, and exercise extreme caution when removing hot accessories from the cooking chamber. Always use proper hand protection when handling or disassembling hot rotisserie accessories.

Cooking Timetable

Food	Setting	Cook Time*	Temperature*	Accessory and Placement
Thin-cut fries (Frozen)	Air Fry / Roast	14 - 18 minutes	400°F / 205°C	Rotisserie Basket
Thin-cut fries (Fresh)	Air Fry / Roast	18 - 20 minutes	400°F / 205°C	Rotisserie Basket
Thick-cut fries (Frozen)	Air Fry / Roast	16 - 20 minutes	400°F / 205°C	Rotisserie Basket
Thick-cut fries (Fresh)	Air Fry / Roast	20 - 25 minutes	400°F / 205°C	Rotisserie Basket
Chicken wings	Air Fry / Roast	20 - 30 minutes	360°F / 182°C	Cooking Tray, Bottom / Rotisserie Basket
Whole chicken (up to 4 lbs)	Roast	55 - 60 minutes	380°F / 193°C	Rotisserie Spit
Chicken nuggets (Frozen)	Broil	10 - 15 minutes	400°F / 205°C	Cooking Tray, Middle
Shrimp (Frozen)	Air Fry	8 minutes	400°F / 205°C	Cooking Tray, Middle / Rotisserie Basket
Shrimp (Fresh)	Air Fry	8 - 10 minutes	350°F / 177°C	Cooking Tray, Middle / Rotisserie Basket
Fish sticks (Frozen)	Broil	8 - 12 minutes	400°F / 205°C	Cooking Tray, Middle
Asparagus	Broil / Bake	7 - 9 minutes	370°F / 188°C	Cooking Tray, Middle / Rotisserie Basket
Cauliflower	Broil / Bake	6 - 10 minutes	370°F / 188°C	Cooking Tray, Middle / Rotisserie Basket
Cake	Bake	25 - 35 minutes	360°F / 182°C	Drip Pan, Bottom (Springform Pan)
Fruit Leather	Dehydrate	8 - 12 hours	140°F / 60°C	Drip Pan, Middle / Bottom
Beef Jerky	Dehydrate	3 - 5 hours	175 °F / 80°C	Cooking Tray, Middle

*Cook times and temperatures are recommendations only. Always follow a trusted recipe.

For a complete cooking timetable, visit [instantappliances.com](https://www.instantappliances.com)



Always use a meat thermometer to ensure the internal temperature reaches a safe minimum temperature. Refer to the USDA's [Safe Minimum Internal Temperature Chart](#) for more information.

Cooking Tips

Instant air fryer ovens cook all your favorite fresh and frozen oven-baked and deep-fried snacks—fast!

- Use the preset Smart Programs as a starting point, and experiment with cooking times and temperatures to get the results you prefer.
- Rotisserie-cooked foods and rotisserie accessories must be placed in the oven before touching **Start**.
- With the exception of rotisserie-cooked foods, most foods benefit greatly from a preheated oven. Wait for the display to read **Add Food** before inserting food into the cooking chamber.
- When cooking coated food items, choose breadcrumb batters over liquid-based batters to ensure that the batter sticks to the food.
- For crispy, golden fries, soak fresh potato sticks in ice water for 15 minutes, then pat dry and spray with cooking oil before adding them to the air fryer oven.
- When baking cakes, pies, quiches, or any food with filling or batter, use an oven-safe baking dish and cover food with foil or an oven-safe lid to prevent the top from overcooking.
- The drip pan doubles as a flat cooking tray. Use the drip pan when cooking fragile or filled food.
- When cooking pizza, insert both cooking trays into the oven and place the pizza on the bottom cooking tray.
- Pat moist food items dry before cooking to prevent smoke, splatter and excess steam.
- Air frying can cause oil and fat to drip from foods. To prevent excess smoke, carefully remove and empty the drip pan periodically throughout cooking.
- To ensure seasoning adheres properly, spray food items with cooking oil before adding seasoning.
- All oven-safe cookware is safe to use in the air fryer oven.

Download the [Instant Pot App](#) or visit our [recipe site](#) for fun, easy-to-follow recipes.



Do not spray cooking oil into the cooking chamber.

Care and Cleaning

Clean your Instant Vortex Plus air fryer oven and accessories after each use. Always unplug the oven and let it cool to room temperature before cleaning. Let all surfaces dry thoroughly before use, and before storage.

Part / Accessory	Instruction	Cleaning Method
Rotisserie Basket	For best results, use a bristled brush rather than a sponge or cloth. Optionally, spray with non-stick cooking spray before adding food.	Dishwasher* or Hand Wash
Rotisserie Spit and Forks	Disassemble before cleaning after each use.	
Cooking Trays	Do not cover cooking trays when cooking. Air must be able to circulate freely. Cooking trays have a non-stick coating. Avoid using metal utensils when cleaning.	
Rotisserie Lift	Clean as needed.	
Drip Pan	Remove for cleaning and ensure all grease and food debris is fully removed. Optionally, line the pan with aluminum foil or parchment paper for easier cleaning.	
Cooking Chamber	Clean the cooking chamber walls as needed. Always check the heating coil for food debris and clean the heating coil as needed. Ensure the heating coil is dry before turning on the air fryer oven.	Damp Cloth Only
Removable Door	Allow to air dry completely before reinstalling.	
Outer Body and Stainless Steel	Clean with a soft, damp cloth or sponge, and wipe dry to avoid streaking.	

**Some discoloration of parts may occur after machine washing. This will not affect the safety nor the performance of the cooker.*

Note: To remove baked-on grease residue from accessories and the cooking chamber, spray the affected area with a mixture of baking soda and vinegar, and wipe clean with a damp cloth. For stubborn stains, allow the mixture to sit on the affected area for several minutes before scrubbing clean.

Care and Cleaning

Remove the Oven Door

1. Place one hand on top of the air fryer oven to hold it firmly in place.
2. Open the oven door to a 45° angle from the oven.
3. Pull the oven door up from the right side until it pops out of its track.

Reinstall the Oven Door

1. Hold the oven door at a 45° angle from the oven.
2. Align the teeth at the bottom of the oven door with the grooves in the air fryer oven.
3. Press down on the right side of the oven door until it pops into place, then press the left side down.

WARNING

Do not immerse the appliance in water. Do not rinse the appliance under a tap. Do not wet the prongs of the power cord.

Without proper cleaning, food and grease splatter may build up around the heating element, causing the risk of smoke, fire, and personal injury.

If you smell smoke, touch **Cancel** and unplug the appliance. Once cool, remove food splatter or grease with a soft cloth and mild detergent.

Troubleshooting

Register your product today.

Contact Customer Care:

1-800-828-7280

support@instantappliances.com

instantappliances.com/#Chat

Problem	Possible Reason	Solution
Air fryer oven is plugged in but will not turn on	The appliance is not properly plugged in	Ensure the power cord is plugged into the outlet firmly.
	Outlet is not powered	Plug in another appliance to the same plug to test the circuit.
		Move the air fryer oven to another plug.
Door is open	Ensure the oven door is closed.	
Black smoke is coming from air fryer oven	 Stop cooking immediately. Cancel the Smart Program, then unplug the oven and allow it to cool to room temperature.	
	Using an oil with a low smoke point	Choose a neutral oil with a high smoke point, such as Virgin or Extra Virgin Olive Oil, Avocado, Canola, Soybean, Safflower, or Rice Bran.
	Food residue on the bottom of the cooking chamber, or accessories	Remove all accessories from the cooking chamber and clean the area as well as all accessories thoroughly.
	Faulty circuit or heating element	Contact Customer Care . Note: Do not attempt to repair the appliance.
White smoke is coming from air fryer oven	Cooking foods with high fat content, such as bacon, sausage, and hamburger	Avoid air frying foods with a high fat content.
		Check drip pan for excess oil or fat and carefully remove as needed.
	Water is vaporizing producing thick steam	Pat dry moist food ingredients before air frying. Do not add water or other liquid to cooking chamber when air frying.
Seasoning on food has blown into element	Be mindful when seasoning food. Spray vegetables and meats before adding seasoning so they adhere to the ingredients.	
All lights flash and a code appears on the display	E1	Broken circuit of the thermal sensor Contact Customer Care .
	E2	Short circuit of the thermal sensor Contact Customer Care .

Any other servicing should be performed by an authorized service representative.

Warranty

Limited Warranty

This Limited Warranty is effective for one year from the date of original consumer purchase. Proof of original purchase date and, if requested by an authorized representative of Instant Brands Inc. ("Instant Brands"), return of your appliance, is required to obtain service under this Limited Warranty. Provided that this appliance is operated and maintained in accordance with written instructions attached to or furnished with the appliance, Instant Brands will, in its sole and exclusive discretion, either: (i) repair defects in materials or workmanship; or (ii) replace the appliance. In the event that your appliance is replaced, the Limited Warranty on the replacement appliance will expire 12 months from the date of original consumer purchase.

This Limited Warranty extends only to the original purchaser and use of the appliance in the United States of America and Canada. This warranty does not cover units that are used outside of the United States of America and Canada.

Any modification or attempted modification to your appliance may interfere with the safe operation of the appliance and will void this Limited Warranty. This Limited Warranty does not apply in respect of any appliance or any part thereof that has been altered or modified unless such alterations or modifications were expressly authorized by an Instant Brands representative.

Limitation and Exclusions

The liability of Instant Brands, if any, for any allegedly defective appliance or part shall in no circumstances exceed the purchase price of a comparable replacement appliance.

This Limited Warranty does not cover:

1. Damage resulting from accident, alteration, misuse, abuse, neglect, unreasonable use, use contrary to the operating instructions, normal wear and tear, commercial use, improper assembly, disassembly, failure to provide reasonable and necessary maintenance, fire, flood, acts of God or repair by anyone unless directed by an Instant Brands Representative;
2. Repairs where your appliance is used for other than normal, personal use or when it is used in a manner that is contrary to published user or operator instructions; or
3. Use of unauthorized parts and accessories, or repairs to parts and systems resulting from unauthorized repairs or modifications made to this appliance.

The cost of repair or replacement under these excluded circumstances shall be paid by you.

Warranty

Disclaimer of Implied Warranties

EXCEPT AS EXPRESSLY PROVIDED HEREIN AND TO THE EXTENT PERMITTED BY LAW, INSTANT BRANDS MAKES NO WARRANTIES, CONDITIONS OR REPRESENTATIONS, EXPRESS OR IMPLIED, BY STATUTE, USAGE, CUSTOM OF TRADE OR OTHERWISE WITH RESPECT TO THE APPLIANCES OR PARTS COVERED BY THIS WARRANTY, INCLUDING BUT NOT LIMITED TO, WARRANTIES, CONDITIONS, OR REPRESENTATIONS OF WORKMANSHIP, MERCHANTABILITY, MERCHANTABILITY QUALITY, FITNESS FOR A PARTICULAR PURPOSE OR DURABILITY.

Some states or provinces do not allow for the exclusion of implied warranties of merchantability or fitness, so this limitation may not apply to you. In these states and provinces, you have only the implied warranties that are expressly required to be provided in accordance with applicable law.

Limitation of Remedies; Exclusion of Incidental and Consequential Damage

YOUR SOLE AND EXCLUSIVE REMEDY UNDER THIS LIMITED WARRANTY SHALL BE APPLIANCE REPAIR OR REPLACEMENT AS PROVIDED HEREIN. INSTANT BRANDS SHALL NOT BE LIABLE FOR INDIRECT, INCIDENTAL OR CONSEQUENTIAL DAMAGES ARISING OUT OF OR IN CONNECTION WITH THE USE OR PERFORMANCE OF THE APPLIANCE OR DAMAGES WITH RESPECT TO ANY ECONOMIC LOSS, PERSONAL INJURY, LOSS OF PROPERTY, LOSS OF REVENUES OR PROFITS, LOSS OF ENJOYMENT OR USE, COSTS OF REMOVAL, INSTALLATION OR OTHER INDIRECT, INCIDENTAL OR CONSEQUENTIAL DAMAGES OF ANY NATURE OR KIND.

Warranty Registration

Please visit www.instantappliances.com/support/register to register your new Instant Brands™ appliance and validate your warranty within thirty (30) days of purchase. You will be asked to provide the store name, date of purchase, model number (found on the back of your appliance) and serial number (found on the bottom of your appliance) along with your name and email address. The registration will enable us to keep you up to date with product developments, recipes and contact you in the unlikely event of a product safety notification. By registering, you acknowledge that you have read and understand the instructions for use, and warnings set forth in the accompanying instructions.

Warranty Service

To obtain service under this warranty, please contact our Customer Service Department by phone at 1-800-828-7280 or by email to support@instantappliances.com. You can also create a support ticket online at www.instantappliances.com/support. If we are unable to resolve the problem, you may be asked to send your appliance to the Service Department for quality inspection. Instant Brands is not responsible for shipping costs related to warranty service, save and except for shipping costs associated with the return of your appliance from Canada or within the 48 contiguous states and the District of Columbia of the United States of America, as provided herein. When returning your appliance, please include your name, mailing address, email address, phone number, and proof of the original purchase date as well as a description of the problem you are encountering with the appliance.





Instant Brands Inc.
11-300 Earl Grey Dr., Suite 383
Ottawa, Ontario
K2T 1C1
Canada

Register your product today
instantappliances.com/support/register

Contact Information

[1-800-828-7280](tel:18008287280)

support@instantappliances.com

instantappliances.com/#Chat

instantappliances.com

store.instantpot.com