



**Instruction Manual
&
Parts Catalog**

**Aluminum
Cargo Carrier**

Model 70108



Read and understand this entire manual before assembling, installing, operating, or servicing this product.

SAVE THIS MANUAL

Copyright© 2012 by Maxx Group, LLC All rights reserved. No portion of this manual or any artwork contained herein may be reproduced in any shape or form without the express written consent of Maxx Group , LLC. Due to continuing improvements, actual product may differ slightly from the product described herein. Tools required for assembly and maintenance may not be included.

IMPORTANT SAFETY INFORMATION

This is a **SAFETY ALERT** symbol.



It is used to alert you to potential personal injury hazards. Obey all safety messages that follow this symbol to avoid possible injury or death.



DANGER indicates a hazardous situation which, if not avoided, will result in death or injury.



WARNING indicates a hazardous situation which, if not avoided, could result in death or serious injury.



CAUTION indicates a hazardous situation which, if not avoided, could result in minor or moderate injury.



NOTICE indicates important information which, if not followed, may cause damage to equipment.

SAVE THIS MANUAL

Keep this manual for the safety warnings and precautions. The manual offers important information on how to assemble, use and maintain this product.

Write the product's model number and purchase date on the cover page of this manual.

Keep this manual (and your purchase receipt) in a safe place.

UNPACKING

The shipment should be thoroughly inspected as soon as it is received. The signed "bill of lading" is acknowledgement by the carrier of receipt in good condition or shipment covered by our invoice. For your own protection, if any of the goods called for on the bill of lading are shorted or damaged, do not accept them until the carrier makes a notation on the freight bill of the shorted or damaged goods.

Notify Maxx Group, LLC immediately if any hidden loss or damage is discovered after receipt.

Definition of Symbols



WARNING concerning Risk of Eye Injury. Wear ANSI approved eye protection.



WARNING concerning Risk of Hearing Loss. Wear hearing protection.



IMPORTANT SAFETY INSTRUCTIONS



1. **Read and understand all safety warnings and instructions.** Failure to follow the warnings and instructions may result in serious injury or death. Save all warnings and instructions for future reference.

2. **Personal and Work Area Safety**



A. **Always wear ANSI approved safety goggles.**



B. **Always wear hearing protection when working in noisy environments.** Prolonged exposure to high intensity noise can cause hearing loss.



C. **Use safety equipment.** Safety shoes, hard hat and work gloves must be used for applicable conditions.

D. **Dress appropriately.** Never wear loose fitting clothing or jewelry when working. Contain long hair, and keep hair, clothing and gloves away from moving parts.

E. **Use common sense when working.** Stay alert and concentrate when setting up and using the Cargo Carrier. Never work while under the influence of alcohol, drugs or medications.

Personal and Work Area Safety (continued)

F. **While assembling and using the Cargo Carrier keep work area clean and well lighted. Keep spectators and children out of the work area.**

3. Use of the Cargo Carrier

A. **The Cargo Carrier must be attached to a 2" x 2" Class III or Class IV hitch receiver.** The hitch must be properly installed by a qualified service technician and be certified to support the weight of this Cargo Carrier and its contents (500 Lbs. capacity).

B. This Cargo Carrier is designed to haul firewood, coolers and other similar loads. **Do not modify the Carrier and do not use this product for purposes that it was not designed for.**

C. **Never exceed the maximum weight capacity of 500 Lbs.**

D. **Be aware of the danger of "dynamic loading".** This situation arises when a load is dropped onto the Carrier, resulting in a short term excessive load. Dynamic loading can result in damage and failure of the Carrier and/or hitch receiver, and personal injury to the person loading the Carrier.

E. **Never load people or animals into the Cargo Carrier.** Keep children and spectators well clear when loading and using this product.

F. **Adhere to all Department of Transportation (D.O.T.) requirements when using this product.** Use ropes and tie downs to securely hold all cargo in place.

G. For the vehicle that will support the Cargo Carrier, read all pertinent vehicle instructions and warnings provided in the owner's manual. **Make sure the vehicle's engine is OFF, with parking brake set, before load-**

ing or unloading the Cargo Carrier.

H. **Weight inside the Cargo Carrier should be evenly distributed, with heavier items positioned towards the center of the Carrier.**

I. **Note the position of the vehicle's exhaust pipes before setting up the Cargo Carrier.** Make sure exhaust pipes are not in close proximity of the Cargo Carrier; flammable goods in the Cargo Carrier could catch on fire due to heat from exhaust. If this risk exists on your vehicle, do not use the Cargo Carrier.

Keep in mind that the warnings previously discussed cannot cover all possible events and circumstances. It is important that the person loading/unloading and using this product use common sense at all times.

Limited Warranty

Maxx Group, LLC warrants to the original retail purchaser that the product is free of defects in material and workmanship at the time of shipment. This Cargo Carrier is warranted for 90 days from the date of purchase. This warranty is expressly in lieu of all other warranties, express or implied.

Proof of purchase is required for warranty transactions; a copy of the original invoice or sales receipt is required.

Assembling and Setting Up the Cargo Carrier

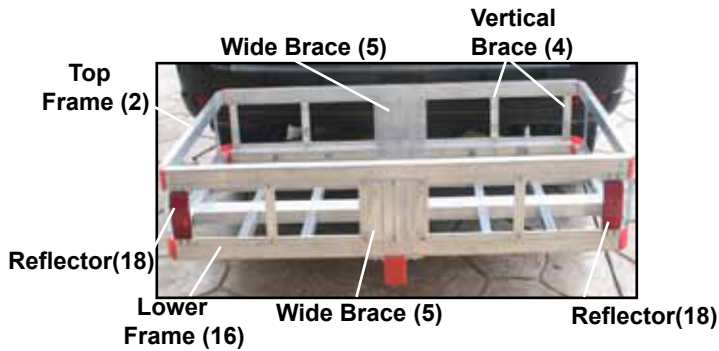

1. Refer to photo above of an already assembled Carrier, and to the Assembly Diagram at end of this manual.

2. Place Lower Frame (16) on the ground. Top Frame (2) is positioned above, and parallel to the Lower Frame as shown above. Connect the Top Frame and Lower Frame with two Wide Braces (5) using three Bolts (13) and three Nuts (14) on top and bottom of Wide Braces.

3. Further support the Top Frame and Lower Frame by attaching the 10 Vertical Braces (4). Use Bolts (13) and Nuts (14) to secure Vertical Braces in place.

4. Put two Brace (17) mounted with Reflecto (18) in place (reflective side facing the rear of Cargo Carrier) using Bolts (13) and Nuts (14).

4. Attach the Hitch Tube (15) to the Lower Frame (16) using the Bolts (21), Washers (22) and Nuts (23). Make sure the tube protrudes out the front end of Cargo Carrier (opposite side of the Reflectors).

5. With all components now assembled make sure all hardware is securely tightened.

WARNING The Cargo Carrier must be attached to a 2" x 2" Class III or Class IV hitch receiver.

7. To place the Cargo Carrier on the vehicle's hitch receiver:

A. First remove the Cotter Pin (8) attached to the Hitch Pin (7).

B. With a helper, lift the empty Cargo Carrier and slide the open end of the Hitch Tube (1) into the vehicle's 2" x 2" hitch receiver.

C. Align the hole openings on hitch receiver and Hitch Tube (15), and put the Hitch Pin (7) in place. Secure Hitch Pin with the Cotter Pin (8).

8. Load the Cargo Carrier as needed. Use ropes and tie downs to securely hold all cargo in place.

WARNING Do not exceed the 500 Lbs. maximum weight capacity. Weight inside the Cargo Carrier should be evenly distributed, with heavier items positioned towards the center of the Carrier.

Maintaining the Cargo Carrier

1. Frequently check the condition of the Cargo Carrier and the vehicle's hitch receiver. Make sure all components are in good condition. If the Cargo Carrier or hitch receiver become damaged through accident, or if any weld damage is noted, the product should be replaced. Check to make sure that all hardware is tightly secured in place. Keep the Cargo Carrier clean.

SPECIFICATIONS

Maximum Weight Capacity	500 Lbs.
Construction	Extruded Aluminum
For Use With	2" x 2" Class III and IV Hitch Receivers
Cargo Basket Dimensions	47-1/4" x 20-1/2" x 6"
Hitch Pin	5/8" Diameter with Cotter Pin
Safety Reflectors	Included

Assembly Drawing

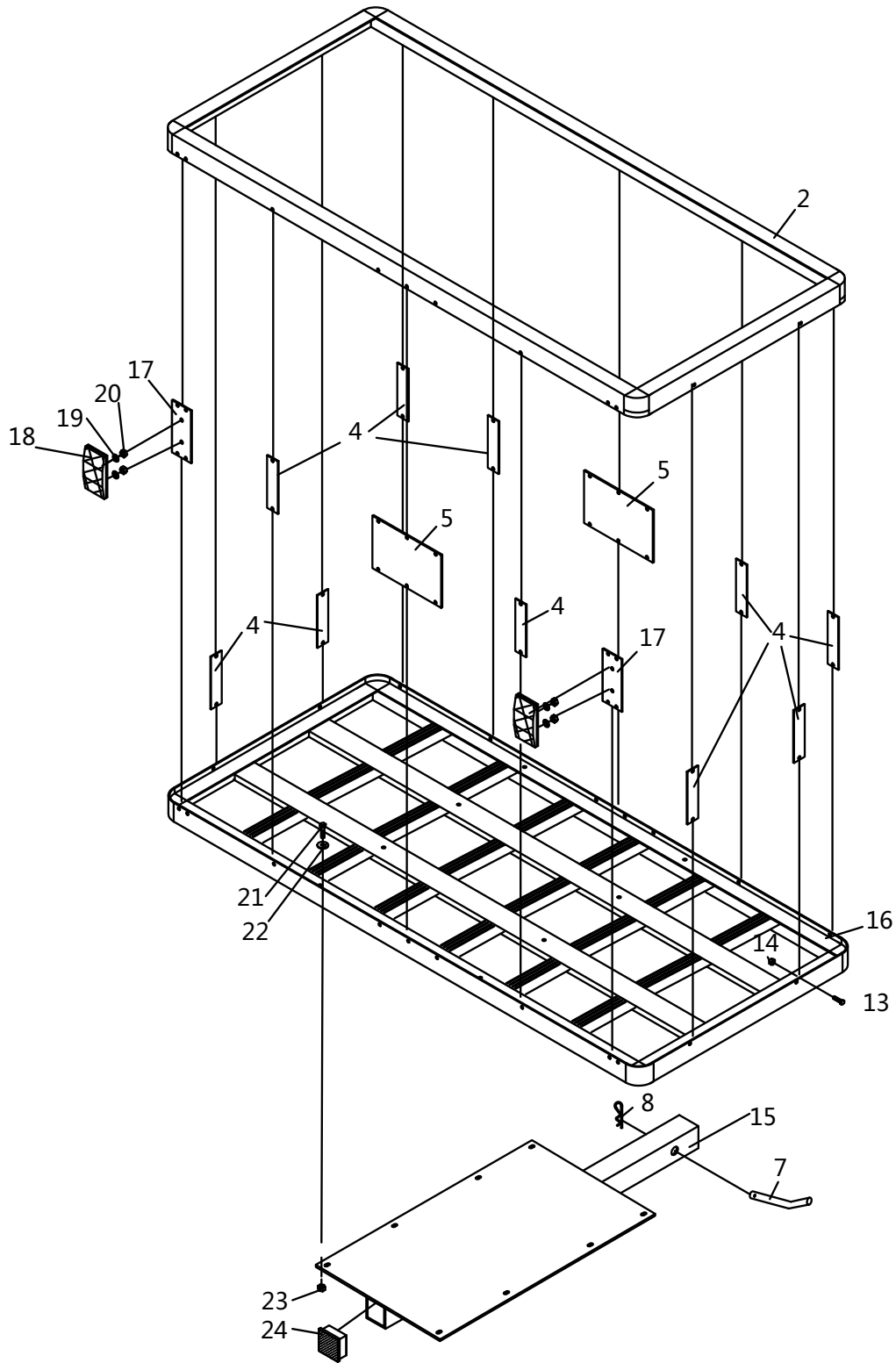

Note: The Parts List and Assembly Diagram is provided as a reference tool only. Some parts are listed and shown for illustration purposes only, and are not available as replacement parts. All repairs to this tool (including replacing parts) should only be done by a qualified service technician.

Parts List

Part #	Description	Qty.	Part #	Description	Qty.
2	Top Frame	1	17	Brace for Reflector	2
4	Vertical Brace	10	18	Reflector	2
5	Wide Brace	2	19	Washer	4
7	Hitch Pin	1	20	Nut	4
8	Cotter Pin	1	21	Bolt M6 X 45	8
13	Bolt M5 x 12	40	22	Washer	16
14	Nut M5	40	23	Nut M6	8
15	Hitch Tube	1	24	End Cap	1
16	Lower Frame	1			

Manufactured and Distributed by:
 Maxx Group, LLC
 Camarillo, CA 93012
www.maxxhaul.com

Maxx Group, LLC ensures complete satisfaction with this product. In the event of missing or damaged parts please call toll free, Customer service hours 9:00-5:00, Monday-Friday, PST., 1-805-987-1333

