

## OPERATOR'S MANUAL

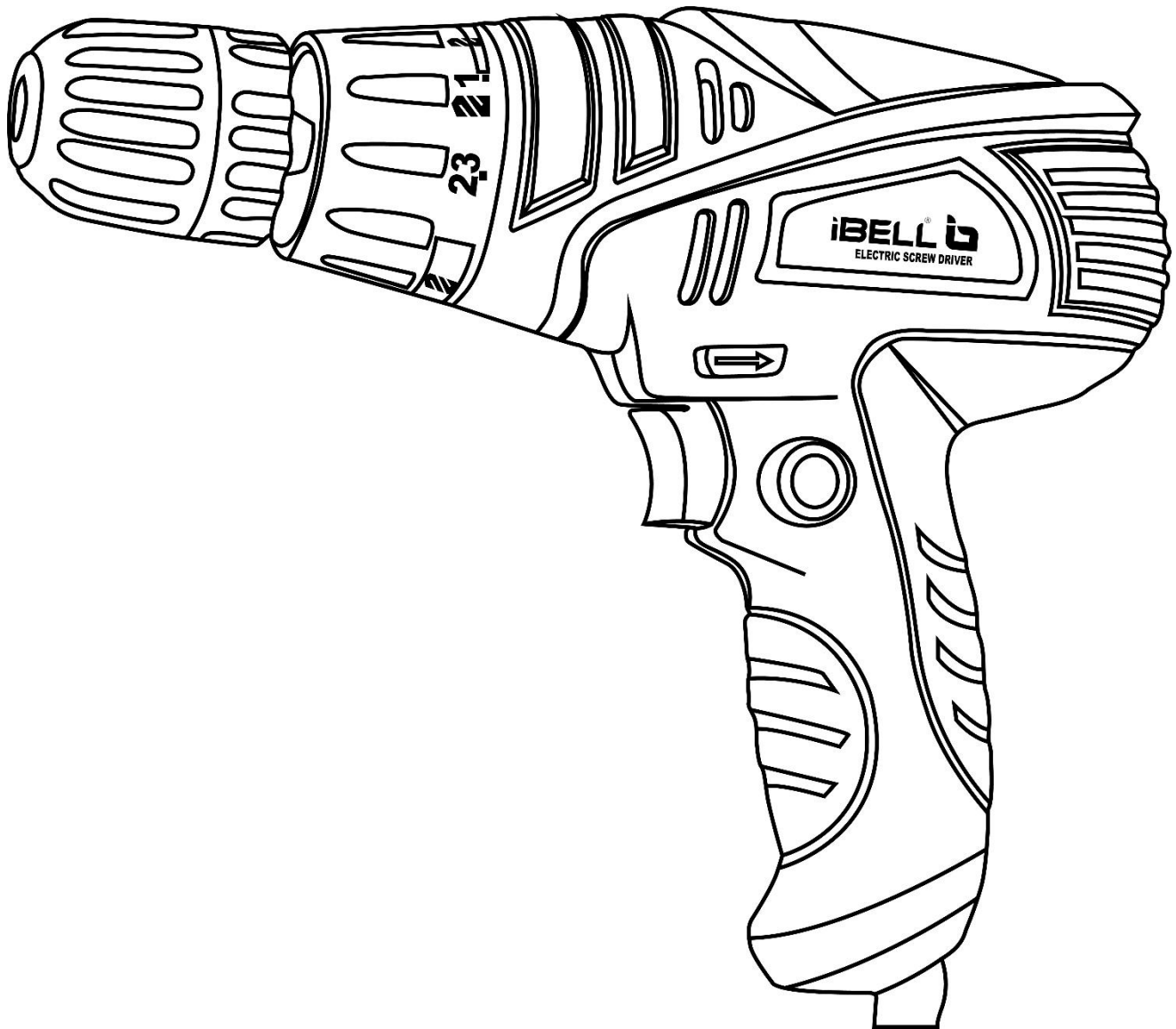

### ELECTRIC SCREWDRIVER

SD10-86|SD12-75

<Read manual carefully before using>

## TABLE OF CONTENTS

1. GENERAL POWER TOOL SAFETY WARNINGS	3
2. ELECTRIC SCREWDRIVER WARNINGS	6
3. PRODUCT OVERVIEW	7
4. PRODUCT SPECIFICATIONS	9
5. SETUP	10
6. PRODUCT FUNCTIONS AND ASSEMBLY	11
7. GENERAL OPERATION	14
8. TROUBLESHOOTING	16

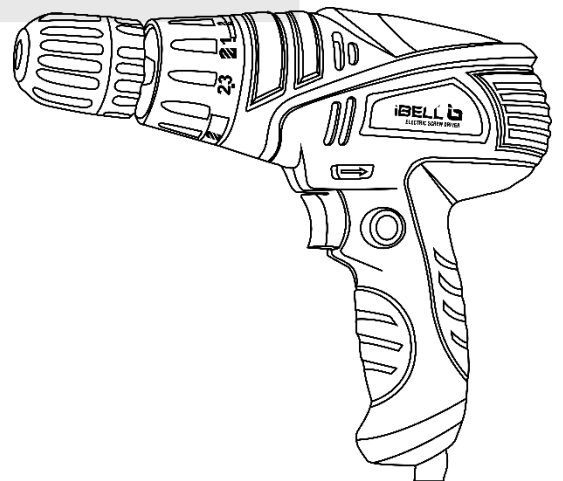

## GENERAL POWER TOOL SAFETY WARNINGS

**⚠ WARNING!** Read all safety warnings, instructions, illustrations and specifications provided with this power tool. Failure to follow all instructions listed below may result in electric shock, fire and/or serious injury. Save all warnings and instructions for future reference. The term “power tool” in the warnings refers to your mains-operated (corded) power tool or battery-operated (cordless) power tool

### WORK AREA SAFETY

- **Keep work area clean and well lit.** Cluttered or dark areas invite accidents.
- **Do not operate power tools in explosive atmospheres, such as in the presence of flammable liquids, gases or dust.** Power tools create sparks which may ignite the dust or fumes.
- **Keep children and bystanders away while operating a power tool.** Distractions can cause you to lose control.

### ELECTRICAL SAFETY

- **Power tool plugs must match the outlet. Never modify the plug in any way.** Do not use any adapted plugs with earthed(grounded) power tools. Modified plugs and un-matching outlets will increase the risk of electric shock.
- **Avoid body contact with earthed or grounded surfaces, such as pipes, radiators, ranges and refrigerators.** There is an increased risk of electric shock if your body is earthed or grounded.
- **Do not expose power tools to rain or wet conditions.** Water entering a power tool will increase the risk of electric shock.
- **Do not abuse the cord.** Never use the cord for carrying, pulling or unplugging the power tool. Keep it away from heat, oil, sharp edges or moving parts.
- **When operating a power tool outdoors, use an extension cord suitable for outdoor use.** Use of a cord suitable for outdoor use reduces the risk of electric shock.

## PERSONAL SAFETY

- **Stay alert, watch what you are doing and use common sense when operating a power tool.** Do not use a power tool while you are tired or under the influence of drugs or alcohol. A moment of inattention while operating power tools may result in serious personal injury.
- **Use personal protective equipment.** Always wear eye protection. Protective equipment such as a dust mask, non-skid safety shoes, hard hat, or hearing protection used for appropriate conditions will reduce personal injuries.
- **Prevent unintentional starting.** Ensure the switch is in the off-position before connecting to power source and/or battery pack, picking up or carrying the tool.
- **Remove any adjusting key or wrench before turning the power tool on.** A wrench or a key left attached to a rotating part of the power tool may result in personal injury.
- **Do not overreach.** Keep proper footing and balance at all times. This enables better control of the power tool in unexpected situations.
- **Dress properly, say no to loose clothing or jewellery.** Keep your hair, clothing away from moving parts. Loose clothes, jewellery or long hair can be caught in moving parts.
- **If devices are provided for the connection of dust extraction and collection facilities, ensure these are connected and properly used.** Use of dust collection can reduce dust-related hazards.

## SERVICE

- **Have your power tool serviced by a qualified repair-person** using only identical replacement parts. This will ensure that the safety of the power tool is maintained.
- **When servicing a power tool, use only identical replacement parts.** Follow instructions in the maintenance section of this manual. Use of unauthorized parts or failure to follow maintenance instructions may create a risk of shock or injury.

## POWER TOOL USE AND CARE

- **Do not force the power tool.** Use the correct power tool for your application. The correct power tool will do the job better and safer at the rate for which it was designed.
- **Do not use the power tool if the switch does not turn it on and off.** Any power tool that cannot be controlled with the switch is dangerous and must be repaired.
- **Disconnect the plug from the power source and/or the battery pack from the power tool before making any adjustments, changing accessories, or storing power tools.** Such preventive safety measures reduce the risk of starting the power tool accidentally.
- **Store idle power tools out of the reach of children and do not allow persons unfamiliar with the power tool or these instructions to operate the power tool.** Power tools are dangerous in the hands of untrained users.
- **Keep cutting tools sharp and clean.** Properly maintained cutting tools with sharp cutting edges are less likely to bind and are easier to control.
- **Keep handles and grasping surfaces dry, clean and free from oil and grease.** Slippery handles and grasping surfaces do not allow for safe handling and control of the tool in unexpected situations.

## RESIDUAL RISKS

**Even if you are operating this product in accordance with all the safety requirements, potential risks of injury and damage remain. The following dangers can arise:**

- Health defects resulting from vibration emission if the product is being used over long periods of time or not adequately managed and properly maintained.
- Injuries and damage to property due to broken cutting attachments or the sudden impact of hidden objects during use.
- Danger of injury and property damage caused by other objects or due to natural reactions or calamities.

## ELECTRIC SCREWDRIVER SAFETY WARNINGS

- **Hold the tool by insulated gripping surfaces when performing an operation.**
- **Use firm pressure while driving in, but do not press too hard.** Too much pressure will not help the process and will cause the bit to overheat, may cause the bit to bend or break, cause undue strain on the tool, and may damage the bit or work piece. Pressing too hard may stall the motor.
- Wear ear protectors. Exposure to noise can cause hearing loss. Always wear safety goggles or eye protection when using this tool. Use a dust mask or respirator for applications which generate dust.
- Place the switch in the locked or 'OFF' position before making any assembly, adjustments or changing accessories. Such preventive safety measures reduce the risk of starting the tool accidentally.
- **Position yourself to avoid being caught between the tool.** When the bit become jammed in the work, the reaction torque of the tool could crush your hand or leg.
- If the bit becomes bound in the work piece, release the trigger immediately, reverse the direction of rotation and slowly press the trigger to back out the bit. Be ready for a strong reaction torque.
- **Do not use dull or damaged bits and accessories.** Dull or damaged bits have a greater tendency to bind in the work piece.
- Do not grasp the tool or place your hands too close to the bit.
- When installing a drivers bit, insert the bit well within the jaws of the chuck. **If the bit is not inserted deep enough, the grip of the jaws over the bit is reduced and the loss of control is increased.**
- **Designate a work area that is clean and well-lit.** The work area must not allow access by children or bystanders to prevent injury and distraction.
- **Do not operate the tool while carrying it at your side.** A spinning driver bit could become entangled with clothing and injury may result.
- **Never attempt to open the product housing for any reason.** If the plastic housing of the product breaks open or cracks, immediately discontinue its use, have it repaired by a technician.



## PRODUCT OVERVIEW

IBL SD 10-86

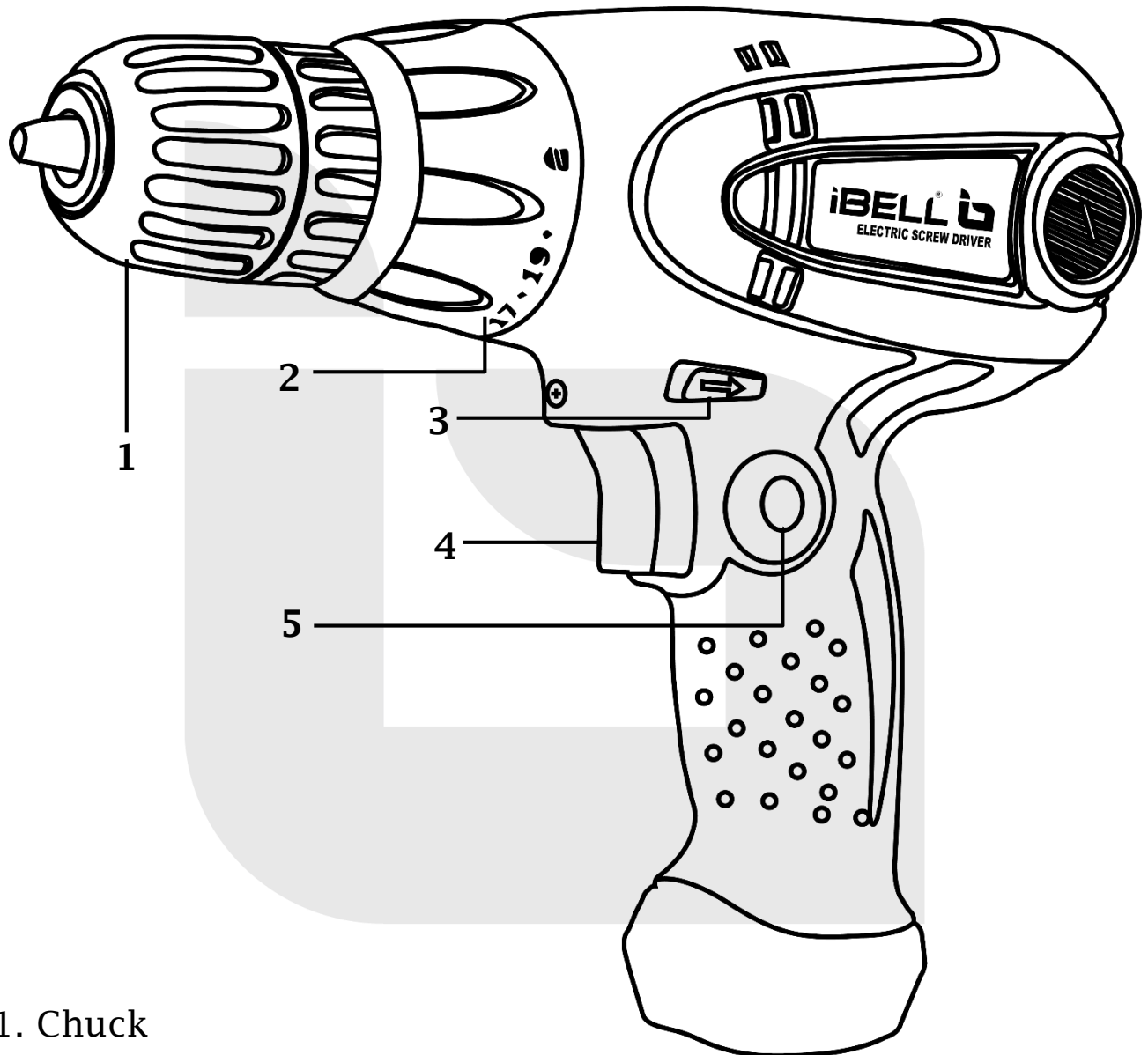

1. Chuck
2. Torque+Mode adjustment ring
3. Forward/Reverse rotation control lever
4. ON/OFF trigger switch
5. Switch lock on button

## IBL SD 12-75

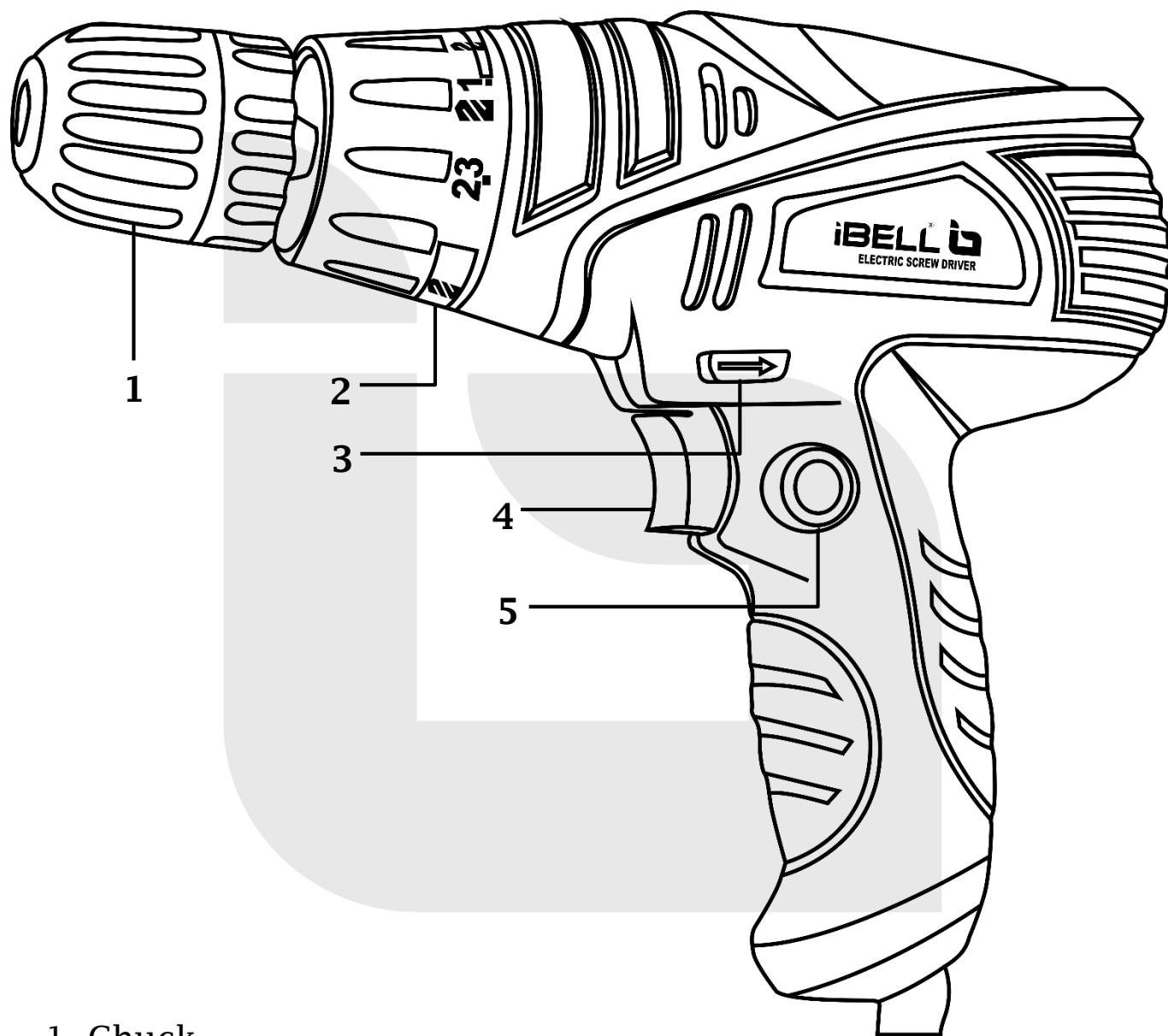

1. Chuck
2. Torque+Mode adjustment ring
3. Forward/Reverse rotation control lever
4. ON/OFF trigger switch
5. Switch lock on button

## PRODUCT SPECIFICATIONS

### IBL SD 10-86

Rated voltage	: 230V~50Hz
Rated Input Power	: 280W
Rated no load speed	: 0-750 rpm
Weight	: 1.35 Kg
Chuck capacity	: 10 mm
Torque	: 19 settings (+1 Drill Mode setting)
Protection class	: Class II

### IBL SD 12-75

Rated voltage	: 230V~50Hz
Rated Input Power	: 280W
Rated no load speed	: 0-750 rpm
Weight	: 1.25 Kg
Chuck capacity	: 10 mm
Torque	: 23 settings (+1 Drill Mode setting)
Protection class	: Class II

## SETUP

### UNPACKING AND ENSURING

- Unpack all parts and lay them on flat, stable surface. Remove all packing materials. Make sure the delivery contents are complete and free of any damage. If you find that parts are missing or show damage, do not use the product but contact your dealer. Using an incomplete or damaged product represents a hazard to people and property.
- Ensure that you have all the accessories and tools needed for assembly and operation. This also includes suitable personal protective equipment.

**⚠ WARNING!** The product must be fully assembled before operation! Do not use a product that is only partly assembled or assembled with damaged parts! Follow the assembly instructions and use the pictures provided as a visual guide to easily assemble the product! Do not connect the product to power supply before it is completely assembled!

### INTENDED USE

- This product is intended for fastening and removing screws majorly. It can also be used for drilling in wood, steel (light purpose only).
- SD10-86 and SD12-75 has 19 and 23 torque settings respectively and one drill setting each.
- It should not be used for working on materials that are dangerous to health. The product is not suitable for heavy duty works.

For safety reasons it is essential to read the entire instruction manual before first operation and to observe all the instructions mentioned in it.

## PRODUCT FUNCTIONS AND ASSEMBLY

### ON/OFF SWITCH AND LOCK-ON BUTTON

Switch the device ON by pressing the ON/OFF switch (4) and OFF by releasing the switch. It is also a variable speed switch that delivers higher speed and torque with higher pressure.

For continuous operation, Press ON/OFF switch then lock-on button (5), release ON/OFF switch first and lock-on button second.

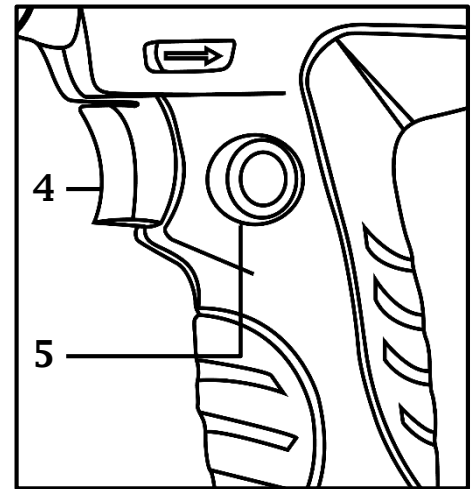

### MOUNTING/ REMOVING BITS

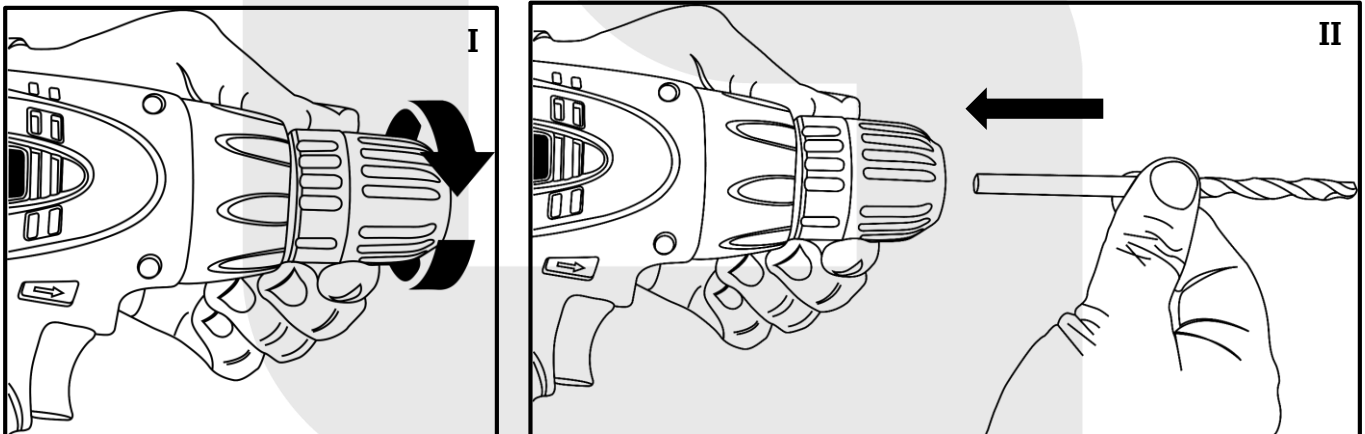

- Turn the chuck sleeve (1) anticlockwise until the chuck jaws are opened wide enough to insert the driver/drill bit.
- Insert the bit all the way to the stop. Turn the chuck sleeve clockwise until the bit is properly fastened in the chuck jaws.
- For removing the bit, simply reverse the above procedure.

**⚠ WARNING!** Always use driver/drill bits according to the intended use! Some bits become hot during use, handle them carefully! Wear protective gloves!

## TORQUE ADJUSTMENT

It is possible to adjust the output torque settings (with a drill mode setting). The torque is adjusted by rotating the torque+ mode adjustment ring (2). Torque is greater when the ring is set on a higher setting and lower when set on a lower setting.

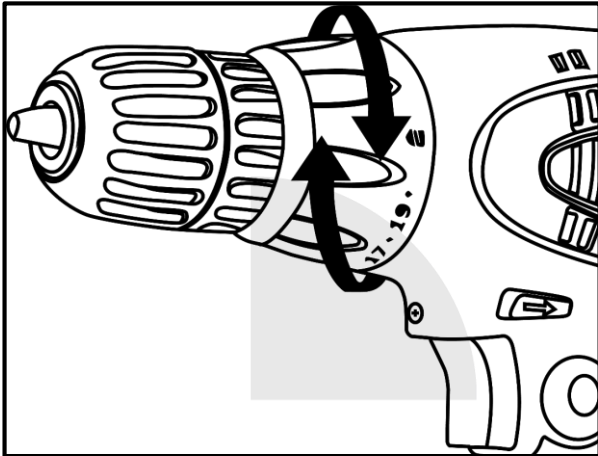

IBL SD10-86

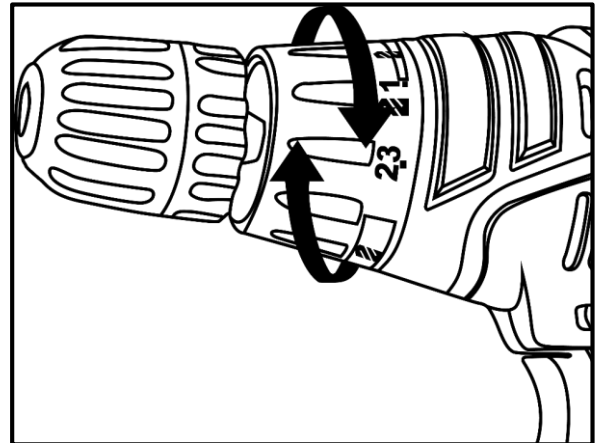

IBL SD12-75

Torque	Description
1 - 4	For driving small screws
5 - 9	For driving screws into soft material
10 - 14	For driving screws into soft and hard material
15 - 19	For driving screws into hard materials
⚡	For drilling in wood, plastic and steel

Torque	Description
1 - 6	For driving small screws
6 - 11	For driving screws into soft material
12 - 18	For driving screws into soft and hard material
19 - 23	For driving screws into hard materials
⚡	For drilling in wood, plastic and steel

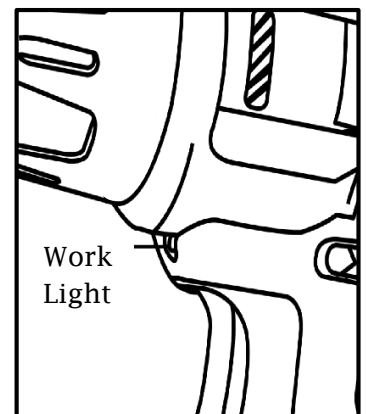

## AUTOMATIC WORK LIGHT

Only for SD 10-86, there is a work light which will automatically illuminate by pressing the ON/OFF switch (4). This helps to focus on the work more thoroughly and could work on a not much bright environment as well.

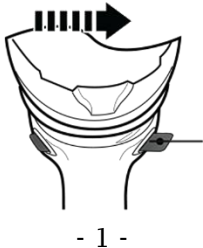
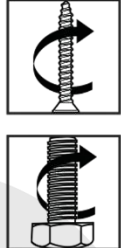
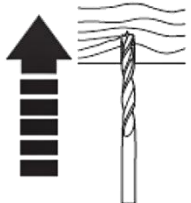
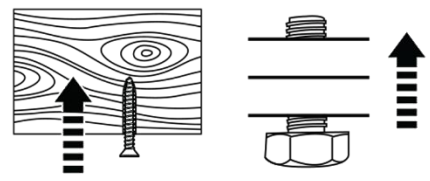
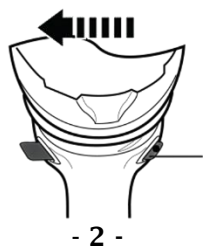
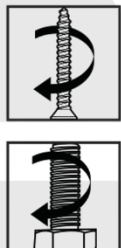
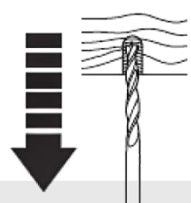
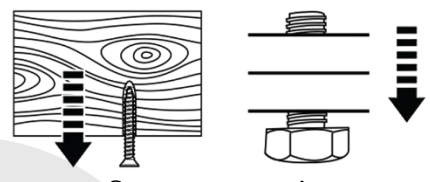
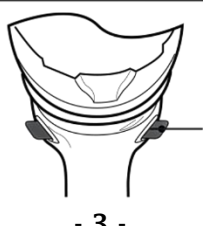
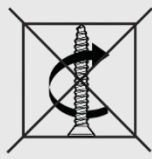

## FORWARD / REVERSE ROTATION CONTROL

Change the rotational direction from forward to reverse by switching the forward/reverse rotation control (3).

Position	Rotational direction	Application	
 <p>- 1 -</p>		 <p>Drilling into material</p>	 <p>Screw-driving</p>
 <p>- 2 -</p>		 <p>Loosen drill bits</p>	 <p>Screw removing</p>
 <p>- 3 -</p>		 <p>Lock the ON/OFF switch and avoid accidental starting</p>	

1. Move the forward/reverse rotation control (3) to the left (as seen from the operator position) in order to use the product in a clockwise rotational mode.
2. Move the forward/reverse rotation control switch to the right (as seen from the operator position) in order to use the product in anticlockwise rotational mode.
3. Move the rotation control switch to the centre position to lock the ON/OFF switch and avoid accidental starting.

**⚠ WARNING!** Only change the rotational direction when the product is switched OFF and has come to a complete stop! Always ensure that the rotation switch is adjusted to the correct position depending on the intended operation! Always slide the control as far as it will go! Do not use the product with the control in any intermediate position!

## GENERAL OPERATION

- **WARNING!** Do not use the product if it is damaged or shows wear. Switch the product off immediately if you are disturbed while working by other people entering the working area.
- Always use sharp bits. Dull or damaged bits may cause undue stress and possibly break, causing injury.
- **Refer specific instructions on page no. 6 before operation.**

- Plug the power cord into a suitable outlet. Slide the direction trigger to determine the rotation direction of the chuck.
- Secure the work piece to keep it from moving during the operation. Use a punch to mark the position of the hole.
- Pre-drill the holes with a smaller diameter of the screw to be screwed. Hold the tool perpendicular to the screw to be screwed in or out. Holding it at an angle may cause slipping or jamming of the driver bit.
- Place the tip of the driver bit directly on the screw first and then switch the product ON.
- You can lock the trigger in the ON position for continuous operation by the trigger, pressing in the lock ON button, and releasing the trigger.
- The trigger has a variable speed feature. Pressing it lightly will make the tool operate slowly, pressing more will cause the tool to operate faster.
- Only apply as much pressure as necessary to keep the screw in place and the driver bit in contact with the screw head. Too much pressure will cause damage to the screw head and driver bit, too little pressure will cause the driver bit to slide away.
- Use the tool only for light drilling, with this same procedure, by changing the torque setting to drill mode.
- Remove blocked and stuck screws by changing the rotational direction. After use, switch the tool OFF and let it cool down.

## CLEANING AND STORAGE

- **Keep your power tool clean.** Remove debris from it after each use and before storage. Do not use chemical, alkaline, abrasive or other aggressive detergents or disinfectants to clean this product as they might be harmful to its surfaces. Regular and proper cleaning will help ensure safe use and prolong the life of the product. Clean the product with a dry cloth. Use a brush for areas that are hard to reach.
- **Always store the product in a place that is inaccessible to children.** We recommend using the original package for storage or covering the product with a suitable cloth or enclosure to protect it against dust.

## MAINTENANCE AND REPAIR

Before and after each use, check the product and accessories (or attachments) for wear and damage.

- **Inspecting the driver/drill bits;** Since use of a dull tool will cause motor malfunctioning and degraded efficiency, replace the bits with a new one or re-sharpen when abrasion is noted.
- **This product does not contain any parts that can be repaired by the consumer.** Contact an authorised service centre or a similarly qualified person to have it checked and repaired.

**⚠ WARNING!** Always switch the product OFF, disconnect the product from the power supply and let the product cool down before performing inspection, maintenance and cleaning work! Only perform repairs and maintenance work according to these instructions! All further works must be performed by a qualified specialist!

## TROUBLESHOOTING

Suspected malfunctions are often due to causes that the users can fix themselves, therefore check the product using this section. In most cases the problem can be solved quickly.

Problem	Possible Cause	Solution
1. Product does not start	1.1 No power supply 1.2 Product damaged  1.3 Other electrical defect to the product	1.1 Check the plug on the power supply 1.2 Check it by an electrician 1.3 Check it by an electrician
2. Unsatisfactory result	2.1 Bit is worn 2.2 Bit not suitable for the intended operation	2.1 Replace with a new one 2.2 Use suitable bit
3. Product suddenly stops	3.1 Product overloaded	3.1 Remove the product from the work-piece and switch it ON again

**⚠ WARNING!** Only perform the steps described within these instructions! All further inspection, maintenance and repair work must be performed by an authorised service centre or a similarly qualified specialist if you cannot solve the problem yourself!



**Waste electrical products should not be disposed of with household waste. Please recycle where facilities exist. Check with your Local Authority or local store for recycling advice.**

Do not dispose this product by normal household waste, but take it to a collection point and recycling of electrical and electronic equipment. This is indicated by the symbol on the product, user manual or packaging. Re-use, material utilization or other forms of old appliances, you make an important contribution in protecting our environment.

## **CONTACT US**

**HiTech Machineries & Equipments  
IV/540E, Thottumugham, P.O, Aluva  
Ernakulam(Dist), Kerala, India- 683105**

**Toll Free : 1800 103 4090**

**Whatsapp : +91 8943 651651**

**Website : [www.ibelltools.com](http://www.ibelltools.com)**

**Email : [icare@ibelltools.com](mailto:icare@ibelltools.com)**

