

ivation®

Portable Air Conditioner with Wi-Fi® User Guide

SKUs: IVAPACWIFI8K / IVAPACWIFI10K / IVAPACWIFI12K / IVAPACWIFI13K



Thank you for purchasing the Ivation® Portable Air Conditioner with Wi-Fi®. This User Guide is intended to provide you with guidelines to ensure that operation of this product is safe and does not pose risk to the user. Any use that does not conform to the guidelines described in this User Guide may void the limited warranty.

Please read all directions before using the product and retain this guide for reference. This product is intended for household use only.

This product is covered by a limited one-year warranty. Coverage is subject to limits and exclusions. See warranty for details.

TABLE OF CONTENTS

- 3** FEATURES
- 4** SAFETY PRECAUTIONS
- 5** PRODUCT OVERVIEW
- 8** INSTALLATION
- 9** USAGE
- 12** CARE
- 15** TROUBLESHOOTING
- 16** SPECIFICATIONS
- 17** WARRANTY
- 18** GET IN TOUCH!

- Wi-Fi® connectivity lets you control your air conditioner from your smartphone
- All-in-one device cools, dehumidifies, and purifies air
- Air swing function adjusts air outlet direction
- Included remote control for simple operation
- Large, easy-to-read LCD display
- Convenient handles on each side make moving your air conditioner easy
- Rear hook for safer power cord storage
- High exhaust vent for easy assembly and better air flow
- Timer switch function allows for automatic shut off
- Automatic compressor, frost, thermal, and overflow protection

- Keep the air conditioner away from gasoline, flammable gas, stoves, and other heat sources.
- Do not use insecticide sprays or other flammable substances near the air conditioner.
- Do not attempt to disassemble, overhaul, or modify the air conditioner. Doing so can cause machine malfunction, property damage, or personal injury. In case of malfunction, contact Ivation® customer service or a qualified professional.
- Do not place liquids or other objects on the air conditioner to prevent damage from accidental spills.
- Operation and maintenance should only be performed by adults. Do not allow children to operate or play with the air conditioner.
- This air conditioner is only suitable for indoor use.
- Do not install or use the air conditioner in bathrooms or other humid environments.
- Ensure that the air conditioner is properly grounded. For questions regarding electrical installation, follow the instructions in this user guide or ask a qualified professional.
- Place the air conditioner in a flat, dry area with at least 20 in. (50 cm) between the air conditioner and walls or surrounding objects.
- When using the drainage hose, ensure that it is properly connected with no blockages or bends.
- After installation, ensure that the power plug is intact and firmly plugged into an appropriate outlet.
- Ensure that the power cord is laid neatly to prevent tripping or accidentally pulling out the power plug.
- Do not power off the air conditioner by pulling out the power plug.
- Keep the air inlet and outlet free of all obstructions.
- Adjust both wind-guide strips on the air outlet by hand to avoid damaging them.
- When moving the air conditioner, keep the unit in an upright position.
- Power off and disconnect the air conditioner before cleaning or performing maintenance.
- Do not clean the air conditioner with chemical solvents like gasoline or alcohol.
- Clean the air conditioner with a damp cloth. For deeper cleaning, use a mild detergent.

GET TO KNOW YOUR AIR CONDITIONER

- 1 Control panel
- 2 Top cover
- 3 Swing leaf air vent
- 4 Rear housing
- 5 Front housing
- 6 Omni-directional wheel
- 7 Exhaust hose assembly
- 8 Window sealing plate assembly
- 9 Remote control
- 10 EVA filter housing
- 11 Power cord hook
- 12 Handle
- 13 Exhaust vent
- 14 Continuous drainage port
- 15 CON filter
- 16 Air inlet grill
- 17 Drainage cover
- 18 Power cord
- 19 Power plug
- 20 Heat preservation sleeve (not included with all models)

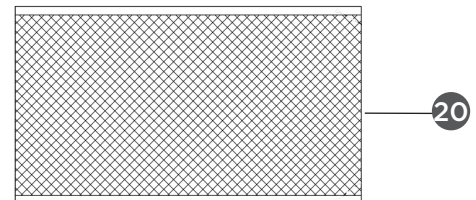
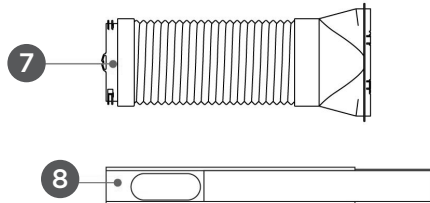
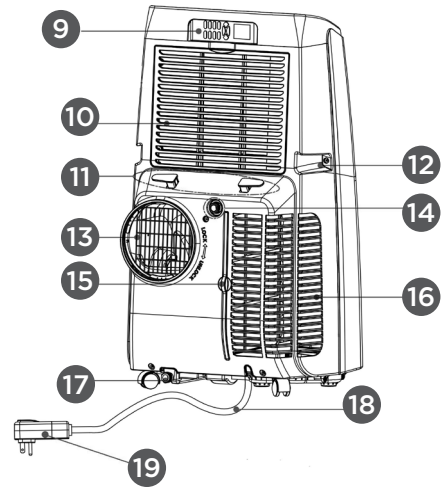
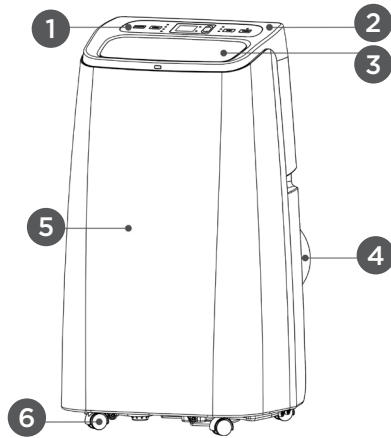

CONTROL PANEL

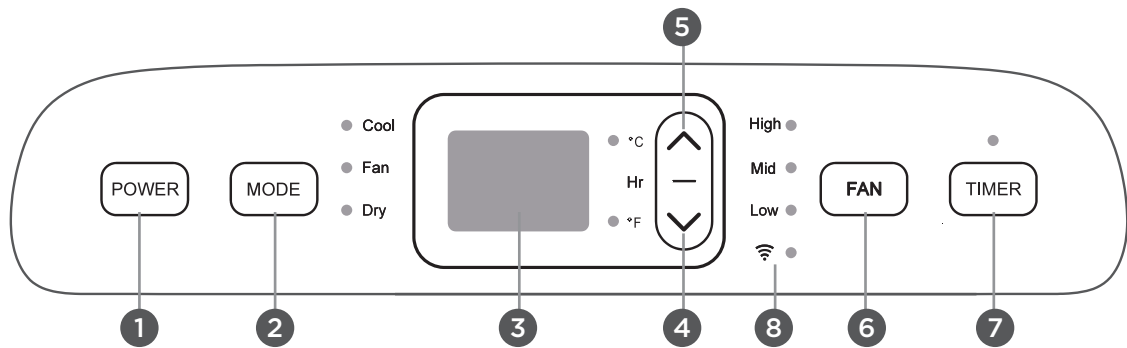

- 1 **Power button:** Power your air conditioner on and off.
- 2 **Mode selection button:** When powered on, select between cooling, ventilation, and dehumidification mode.
- 3 **LCD display:** View selected temperature and operating conditions.
- 4 **Down button:** Lower your selected temperature or timing value.
- 5 **Up button:** Raise your selected temperature or timing value.
 - a. To switch between Fahrenheit (°F) and Celsius (°C), simultaneously press both the up and down button.
- 6 **Fan speed button:** Toggle between high, medium, and low fan speeds.

NOTE: Fan speed is not selectable in dehumidifying mode.
- 7 **Timer button:** Select automated power on and off.
 - a. When powered off, press the timer button to open the timer menu and use the up and down buttons to choose when to power on the air conditioner.
 - b. When powered on, press the timer button to open the timer menu and use the up and down buttons to choose when to power off the air conditioner.
 - c. Timing values can be set between 1-24 hour(s) in one-hour increments.
- 8 **Wi-Fi indicator light:** Indicates whether or not the air conditioner is connected to Wi-Fi.

REMOTE CONTROL

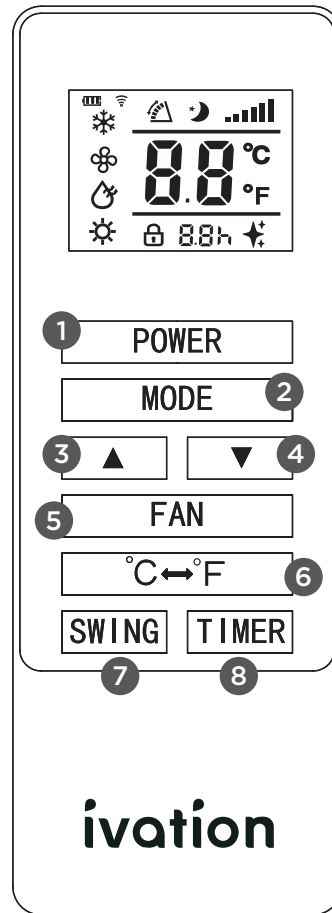

- 1 **Power:** Power your air conditioner on and off.
- 2 **Mode:** Select between cooling, ventilation, and dehumidification mode.
- 3 **Up:** Raise selected temperature or timing value.
- 4 **Down:** Lower selected temperature or timing value.
- 5 **Fan:** Toggle between high, medium, and low fan speeds.
- 6 **°C ↔ °F:** Toggle between Fahrenheit (°F) and Celsius (°C).
- 7 **Swing:** Select automated power on and off.
- 8 **Timer:** Set the timing value.

AIR CONDITIONER PLACEMENT

When selecting a place to install your air conditioner, consider the following:

- Before powering on your air conditioner, let it stand upright for at least two (2) hours.
- Keep your air conditioner upright whenever you move it.
- Do not install your air conditioner in bathrooms or other humid environments.

EXHAUST HOSE ASSEMBLY

- If your air conditioner included a heat preservation sleeve, place it over the exhaust hose assembly before attaching it to the unit.
- Align the exhaust hose assembly with the exhaust vent. Screw the exhaust hose assembly counterclockwise to fasten into place.

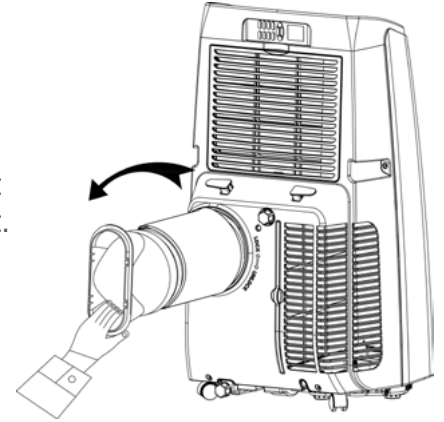

WINDOW SEALING PLATE ASSEMBLY

- Open your selected window halfway and mount the window sealing plate. The window sealing plate can be installed horizontally or vertically.
- Slide the window sealing plate assembly open until both ends are in contact with the window frame. Set in place using the clips.

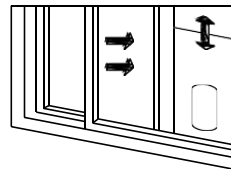
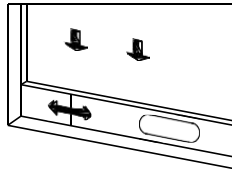

INSTALLING THE AIR CONDITIONER

- Move your air conditioner with the exhaust hose assembly installed toward the window. Be sure to leave at least 20" (50 cm) between your air conditioner and walls or surrounding objects.
- Extend the exhaust hose assembly and snap the flat end of the hose joints into the window sealing plate assembly.

NOTES: The flat end of the hose joints must be snapped into place.

Make sure the exhaust hose does not have bends or angles greater than 45 degrees. Keep the ventilation of the hose unobstructed.

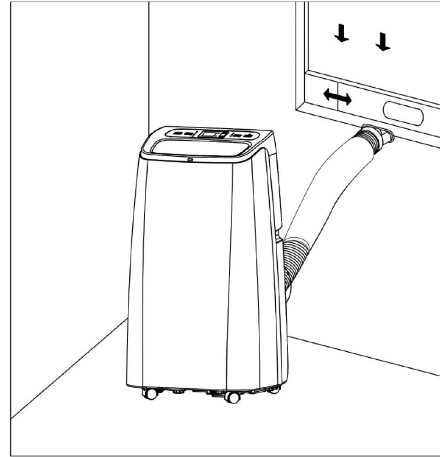
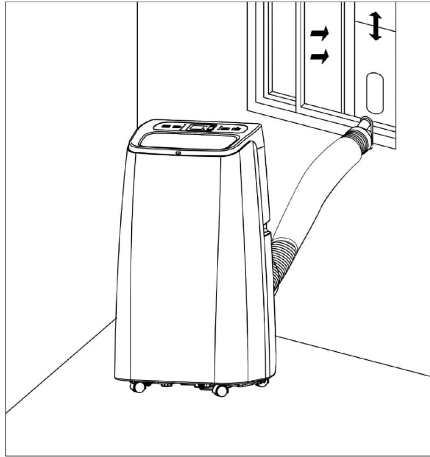

EXHAUST HOSE NOTE

The exhaust hose length must be between 11" – 59" (28 – 150 cm) based on your specific model. Do not use extension tubes or hoses other than the one provided in the package. Keep the exhaust hose unobstructed to prevent overheating.

USING YOUR AIR CONDITIONER WITH WI-FI®

Download the My Ivation® App

Scan the QR Code below with your smartphone to download the My Ivation® app in the App Store® or Google Play™.

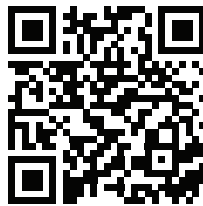

NOTE: Allow the app to access network and location services for best use.

Create New Account

- Press "Register" and follow the prompts to register your account.

Add Device (EZ Mode)

- Plug the unit into an outlet, but do not power on the unit. Hold the Fan button for three (3) seconds until the unit beeps and the indicator light blinks rapidly.
- From the Home Page, press “Add Device” or press + in the top right corner of the screen. (If you already have a device added to your account, the “Add Device” button will not appear.)

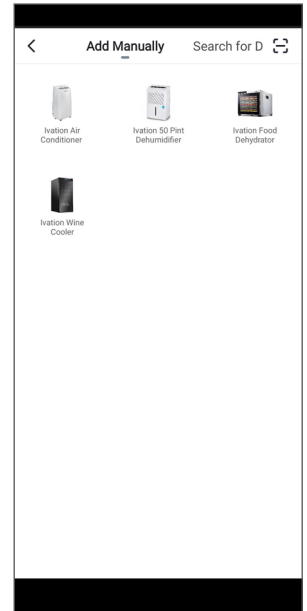

- In the app, select your air conditioner model from the device menu. When the indicator light on the unit blinks rapidly:
 - Press “Confirm”.
 - Select your Wi-Fi® network.
 - Enter your router password.

NOTE: Connection may take up to 60 seconds.
- Once complete, the indicator light will stop blinking and remain lit.
- Once the device is added, you can use the menu of the app to change the name and location of the device.
- When you are finished, press “Done”.

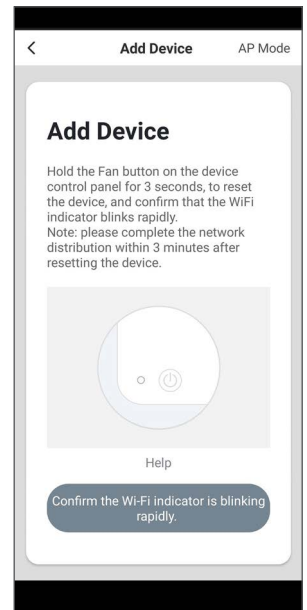

Add Device (AP Mode)

If you are having trouble connecting to your device using EZ mode, you may connect to it using AP mode by following the instructions below.

- Plug the unit into an outlet, but do not power on the unit. Hold the Fan button for three (3) seconds until the unit beeps and the indicator light blinks rapidly. Hold the Fan button a second time for three (3) seconds until the indicator light blinks slowly.

- From the Home Page, press “Add Device” or press + in the top right corner of the screen. (If you already have a device added to your account, the “Add Device” button will not appear.)
- Select your air conditioner model from the device menu.
- In the app, select “AP Mode” in the top right corner, then press “Confirm”.
- The next screen will say “Connect your mobile phone to the device’s hotspot”. Press “Go to connect”.
- Your phone will automatically enter its settings menu (or Wi-Fi® list for Android™). Select the Wi-Fi network “SL-Ivation-XXXX”.
- Navigate back to the My Ivation App and press “Next”. Your phone will initiate connection.
NOTE: Connection may take up to 60 seconds.
- Once complete, the indicator light will stop blinking and remain lit.
- Once the device is added, you can use the menu to change the name and location of the device.
- When you are finished, press “Done”.

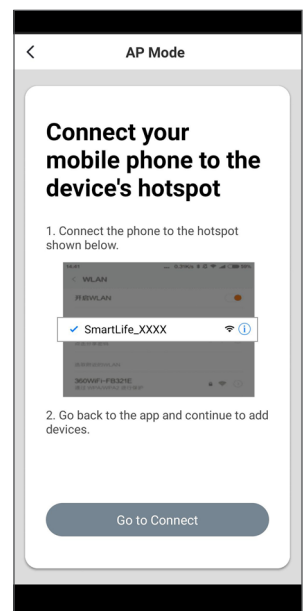
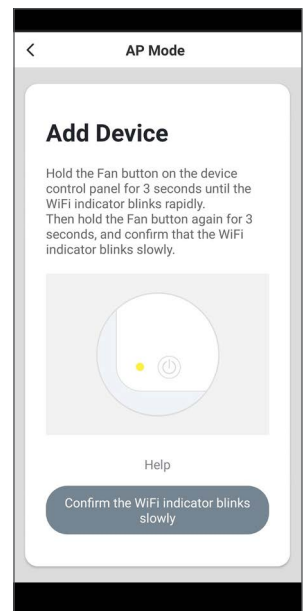
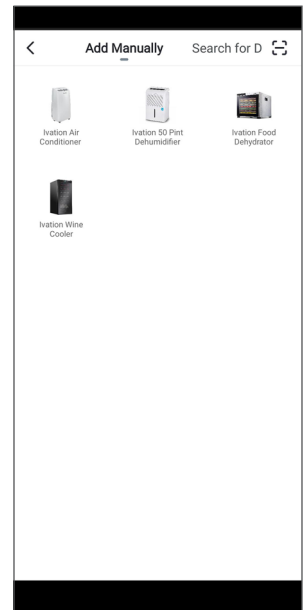

Using the My Ivation® App

- 1. Device Settings**
Access device name, location, and sharing settings
- 2. Temperature Display**
Toggle between Celsius and Fahrenheit temperature readings by tapping the °C or °F next to the number
- 3. Mode Icons**
Displays your device’s current operating settings
- 4. Mode**
Toggle between cool, fan, and dry modes
- 5. Fan**
Select the fan speed
- 6. Swing**
Turn the fan swing on and off
- 7. Timer**
Set a timer for when your device turns on/off
- 8. Schedule**
Set a run schedule for your device
- 9. Temp**
Adjust your temperature setting up or down
- 10. On/Off**
Power your device on or off
- 11. Night Mode**
Toggle Night Mode on and off

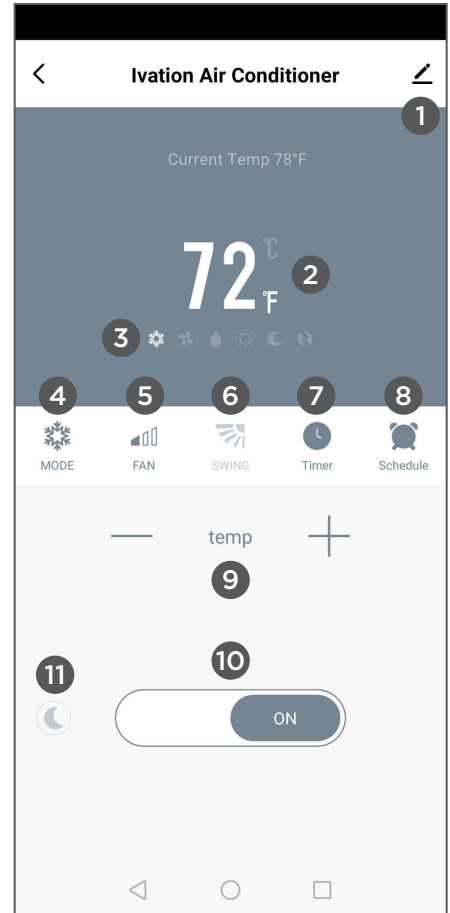

AUTOMATED PROTECTION FEATURES

Frost Protection

Should the temperature of the exhaust hose become too low, your air conditioner will automatically enter frost protection mode. Once the exhaust hose rises back to a normal operating temperature, your air conditioner will revert back to normal operation. This feature will only work in cooling, dehumidification, or power saving modes.

Overflow Protection

If the water level in the reservoir exceeds a certain amount, the air conditioner will beep and the LCD display will read “FL”. To resume normal operation, connect a drainage hose or use the water plug to empty the unit. For more detailed instructions on draining your unit, see the Drainage Instructions section of this User Guide.

Automatic Defrosting

If the air conditioner detects frost buildup, the unit will automatically defrost. Defrosting is indicating by a heating symbol flashing on the LCD screen.

Automatic Thermal Protection

Should the air conditioner become too hot, the unit will enter automatic thermal protection. When in this protection, the compressor and lower motor will stop operating until the unit cools down. Once the air conditioner is within operating temperatures again, normal operation will resume.

Compressor Protection

To extend the life of your compressor, the compressor will power on after a three (3) minute delay when the unit is turned off and on again.

DRAINAGE INSTRUCTIONS

Manual Drainage

- Before manually draining your air conditioner, power off and unplug the unit.
NOTE: Move the air conditioner carefully to prevent spills.
- Align the water plug with the receptacle you plan to drain the water into.
- Unscrew the water plug and let the water drain out naturally.
NOTES: To ensure complete draining, tip the air conditioner back slightly. If the receptacle you are draining water into is not large enough, simply reinsert the water plug to stop draining.
- With the unit drained, reinsert the water plug and tighten the drainage cover. Make sure each is properly set before restarting the unit.
NOTE: Restart the air conditioner after the water plug and drain cover are reinstalled to prevent condensation from dripping onto the floor.

Continuous Drainage

- Unscrew the drainage cover and remove the water plug.
- Insert the drainage hose into the water outlet.
- Run the drainage hose to a receptacle.



CARE & MAINTENANCE

Before performing any cleaning or maintenance on your air conditioner, power off and unplug the unit.

Cleaning the Housing

Clean the front and rear housings with a damp cloth. Do not use chemicals like benzene or alcohol to avoid damaging the air conditioner.

Cleaning the Filter Screens

If the filter screen is clogged with dust, the effectiveness of the air conditioner will be reduced. For best results, clean the filter screen once every two (2) weeks.

Cleaning the EVA Filter Screen Frame

- Grab the wedging block of the EVA filter screen frame and slide it downward to remove.
- Remove the four (4) screws that connect the EVA filter screen to the rear housing to free the screen.
- Remove all lint and dust from the filter with a vacuum cleaner.
- Soak the EVA filter screen in warm water with neutral detergent (roughly 104 °F/40 °C).
- Rinse the filter screen and let it dry in a shady area before reinstalling.

Cleaning the CON Filter Screen Frame

- Pull the handle of the CON filter screen frame gently to remove it from the air conditioner.
- Remove all lint and dust from the filter with a vacuum cleaner.
- Soak the CON filter screen in warm water with neutral detergent (roughly 104 °F/40 °C).
- Rinse the filter screen and let it dry in a shady area before reinstalling.

Seasonal Storage Preparations

- Power off the air conditioner, unplug the power plug, and wrap the power cord around the power cord hook.
- Unscrew the drainage cover and water plug and drain the air conditioner completely.
- Run the air conditioner on a low fan speed in ventilation mode to dry out the inside of unit. This will prevent mildew from forming in storage. Reinstall the water plug and drainage cover once completely dry.
- Remove the exhaust hose and store it in a safe place.
- Cover the air conditioner and store it in a safe, dry place. Use the original packaging or a plastic bag to cover the unit.
- Remove the batteries from the remote control to prevent acid damage.

TROUBLESHOOTING

Issues	Possible Causes	Probable Solutions
The air conditioner does not operate.	Electricity is not flowing to the air conditioner.	Connect the air conditioner to an appropriate outlet.
	The reservoir is full, indicated by the LCD display reading "FL".	Drain the water from inside the reservoir.
	The ambient temperature is not within operating range.	Use the unit in temperatures between 44 °F - 95 °F (7 °C - 35 °C).
	In cooling mode, the room temperature is lower than the set temperature.	Change the set temperature.
	In dehumidification mode, the ambient temperature is too low.	Place the air conditioner in a room with a temperature above 62 °F (17 °C).
The air conditioner does not cool as it should.	The air conditioner is in direct sunlight.	Move the air conditioner out of direct sunlight.
	Doors and windows may be open, or other sources of heat are present.	Close all doors and windows in the room you wish to cool.
	The filter screen is dirty.	Clean or replace the filter screen.
	The air inlet or outlet is blocked.	Clear any obstructions for the air inlet and outlet.
The air conditioner is noisy when in operation.	The air conditioner is not placed on a level surface.	Move the air conditioner to a level surface.
The remote control does not work.	The remote control is too far from the air conditioner.	Bring the remote control closer to the air conditioner and face it directly toward the receiver.
	The remote control is not aligned with the remote-control receiver.	
	The batteries in the remote control are dead.	Replace the batteries.
The LCD display reads "E1".	There is an issue with the hose temperature sensor.	Check the hose temperature sensor for issues.
The LCD display reads "E2".	There is an issue with the room temperature sensor.	Check the room temperature sensor for issues.

IVAPACWIFI8K

Cooling Capacity: 8,500 BTU/hr
SACC: 5,500 BTU/hr
Dehumidification: 55 pts/day
Cooling Power Usage: 860 W / 7.5 A
Air Flow: 175 CFM
Power Source: 115 V / 60 Hz
Noise Level: 53 dB
Product Weight: 46.3 lbs. (21 kg)
Operating Temperature: 60 °F - 86 °F (16 °C - 30 °C)
Refrigerant: R-410A

IVAPACWIFI10K

Cooling Capacity: 10,000 BTU/hr
SACC: 6,500 BTU/hr
Dehumidification: 65 pts/day
Cooling Power Usage: 1,090 W / 9.5 A
Air Flow: 210 CFM
Power Source: 115 V / 60 Hz
Noise Level: 55 dB
Product Weight: 58.4 lbs. (26.5 kg)
Operating Temperature: 60 °F - 86 °F (16 °C - 30 °C)
Refrigerant: R-410A

IVAPACWIFI12K

Cooling Capacity: 12,000 BTU/hr
SACC: 8,000 BTU/hr
Dehumidification: 90 pts/day
Cooling Power Usage: 1,150 W / 10 A
Air Flow: 225 CFM
Power Source: 115 V / 60 Hz
Noise Level: 55 dB
Product Weight: 60.6 lbs. (27.5 kg)
Operating Temperature: 60 °F - 86 °F (16 °C - 30 °C)
Refrigerant: R-410A

IVAPACWIFI13K

Cooling Capacity: 13,000 BTU/hr
SACC: 8,500 BTU/hr
Dehumidification: 105 pts/day
Cooling Power Usage: 1,150 W / 10 A
Air Flow: 225 CFM
Power Source: 115 V / 60 Hz
Noise Level: 55 dB
Product Weight: 62.8 lbs. (28.5 kg)
Operating Temperature: 60 °F - 86 °F (16 °C - 30 °C)
Refrigerant: R-410A

LIMITED WARRANTY TO ORIGINAL CONSUMER

This Ivation® Portable Air Conditioner with Wi-Fi® (“Product”), including any accessories included in the original packaging, as supplied and distributed new by an authorized retailer is warranted by C&A Marketing, Inc. (the “Company”) to the original consumer purchaser only, against certain defects in material and workmanship (“Warranty”) as follows:

To receive Warranty service, the original consumer purchaser must contact the Company or its authorized service provider for problem determination and service procedures. Proof of purchase in the form of a bill of sale or receipted invoice, evidencing that the Product is within the applicable Warranty period(s), MUST be presented to the Company or its authorized service provider in order to obtain the requested service.

Service options, parts availability, and response times may vary and may change at any time. In accordance with applicable law, the Company may require that you furnish additional documents and/or comply with registration requirements before receiving warranty service. Please contact our customer service for details on obtaining warranty service:

info@myivation.com

866-849-3049

Shipping expenses to the Company’s Return Facility are not covered by this warranty, and must be paid by the consumer. The consumer likewise bears all risk of loss or further damage to the Product until delivery to said facility.

EXCLUSIONS AND LIMITATIONS The Company warrants the Product against defects in materials and workmanship under normal use for a period of ONE (1) YEAR from the date of retail purchase by the original end-user purchaser (“Warranty Period”). If a hardware defect arises and a valid claim is received within the Warranty Period, the Company, at its sole option and to the extent permitted by law, will either (1) repair the Product defect at no charge, using new or refurbished replacement parts, (2) exchange the Product with a Product that is new or which has been manufactured from new or serviceable used parts and is at least functionally equivalent to the original device, or (3) refund the purchase price of the Product.

A replacement Product or part thereof shall enjoy the warranty of the original Product for the remainder of the Warranty Period, or ninety (90) days from the date of replacement or repair, whichever provides you longer protection. When a Product or part is exchanged, any replacement item becomes your property, while the replaced item becomes the Company’s property. Refunds can only be given if the original Product is returned.

This Warranty does not apply to:

- (a) Any non-Ivation® Portable Air Conditioner with Wi-Fi® product, hardware or software, even if packaged or sold with the Product;
- (b) Damage caused by use with non-Ivation® Portable Air Conditioner with Wi-Fi® products;
- (c) Damage caused by accident, abuse, misuse, flood, fire, earthquake, or other external causes;
- (d) Damage caused by operating the Product outside the permitted or intended uses described by the Company;
- (e) Damage caused by third party services;
- (f) A Product or part that has been modified to alter functionality or capability without the written permission of the Company;
- (g) Consumable parts, such as batteries, fuses, and bulbs;
- (h) Cosmetic damage; or
- (i) If any Ivation® Portable Air Conditioner with Wi-Fi® serial number has been removed or defaced.

This Warranty is valid only in the country where the consumer purchased the Product, and only applies to Products purchased and serviced in that country.

The Company does not warrant that the operation of the Product will be uninterrupted or error-free. The Company is not responsible for damage arising from your failure to follow instructions relating to its use.

NOTWITHSTANDING ANYTHING TO THE CONTRARY AND TO THE MAXIMUM EXTENT PERMITTED BY APPLICABLE LAW, THE COMPANY PROVIDES THE PRODUCT “AS-IS” AND “AS-AVAILABLE” FOR YOUR CONVENIENCE AND THE COMPANY AND ITS LICENSORS

AND SUPPLIERS EXPRESSLY DISCLAIM ALL WARRANTIES AND CONDITIONS, WHETHER EXPRESSED, IMPLIED, OR STATUTORY, INCLUDING THE WARRANTIES OF MERCHANTABILITY, FITNESS FOR A PARTICULAR PURPOSE, TITLE, QUIET ENJOYMENT, ACCURACY, AND NON-INFRINGEMENT OF THIRD-PARTY RIGHTS. THE COMPANY DOES NOT GUARANTEE ANY SPECIFIC RESULTS FROM THE USE OF THE PRODUCT, OR THAT THE COMPANY WILL CONTINUE TO OFFER OR MAKE AVAILABLE THE PRODUCT FOR ANY PARTICULAR LENGTH OF TIME. THE COMPANY FURTHER DISCLAIMS ALL WARRANTIES AFTER THE EXPRESS WARRANTY PERIOD STATED ABOVE.

YOU USE THE PRODUCT AT YOUR OWN DISCRETION AND RISK. YOU WILL BE SOLELY RESPONSIBLE FOR (AND THE COMPANY DISCLAIMS) ANY AND ALL LOSS, LIABILITY, OR DAMAGES RESULTING FROM YOUR USE OF THE PRODUCT.

NO ADVICE OR INFORMATION, WHETHER ORAL OR WRITTEN, OBTAINED BY YOU FROM THE COMPANY OR THROUGH ITS AUTHORIZED SERVICE PROVIDERS SHALL CREATE ANY WARRANTY.

IN NO EVENT WILL THE COMPANY'S TOTAL CUMULATIVE LIABILITY ARISING FROM OR RELATED TO THE PRODUCT, WHETHER IN CONTRACT OR TORT OR OTHERWISE EXCEED THE FEES ACTUALLY PAID BY YOU TO THE COMPANY OR ANY OF ITS AUTHORIZED RESELLERS FOR THE PRODUCT AT ISSUE IN THE LAST YEAR FROM YOUR PURCHASE. THIS LIMITATION IS CUMULATIVE AND WILL NOT BE INCREASED BY THE EXISTENCE OF MORE THAN ONE INCIDENT OR CLAIM. THE COMPANY DISCLAIMS ALL LIABILITY OF ANY KIND OF ITS LICENSORS AND SUPPLIERS. IN NO EVENT WILL THE COMPANY OR ITS LICENSORS, MANUFACTURERS AND SUPPLIERS BE LIABLE FOR ANY INCIDENTAL, DIRECT, INDIRECT, SPECIAL, PUNITIVE, OR CONSEQUENTIAL DAMAGES (SUCH AS, BUT NOT LIMITED TO, DAMAGES FOR LOSS OF PROFITS, BUSINESS, SAVINGS, DATA, OR RECORDS) CAUSED BY THE USE, MISUSE, OR INABILITY TO USE THE PRODUCT.

Nothing in these terms shall attempt to exclude liability that cannot be excluded under applicable law. Some countries, states, or provinces do not allow the exclusion or limitation of incidental or consequential damages or allow limitations on warranties, so certain limitations or exclusions may not apply to you. This warranty gives you specific legal rights, and you may have other rights that vary from state to state or province to province. Contact your authorized retailer to determine if another warranty applies.

GET IN TOUCH!

✉ info@myivation.com

☎ 1-866-849-3049

IVATION is a trademark of C&A IP Holdings, LLC, in the U.S.

WI-FI is a trademark of Wi-Fi Alliance in the U.S. and/or other countries.

APP STORE is a trademark of Apple, Inc. in the U.S. and other countries.

GOOGLE PLAY is a trademark of Google, LLC.

All other products, brand names, company names, and logos are trademarks of their respective owners, used merely to identify their respective products, and are not meant to connote any sponsorship, endorsement, or approval.

Distributed by C&A Marketing, Inc., 114 Tived Lane East, Edison, NJ 08837.

Made in China.

© 2021. C&A IP Holdings, LLC. All Rights Reserved.