

TECHNICAL INFORMATION



PRODUCT

P 1 / 20

Models No. ▶ LH1040, LH1040F

Description ▶ Table Top Miter Saw 260mm (10-1/4")

CONCEPT AND MAIN APPLICATIONS

Models LH1040 and LH1040F have been developed as multi-purpose miter saws. Installation of a table on Model LH1040 has enabled miter saw and table saw to be packed in one tool for great versatility. LH1040F features LED built-in job light for accurate tracing of ink line in dark places.

Dimensions: mm (")	
Length (L)	530 (20-7/8)
Width (W)	476 (18-3/4)
Height (H)	535 (21)

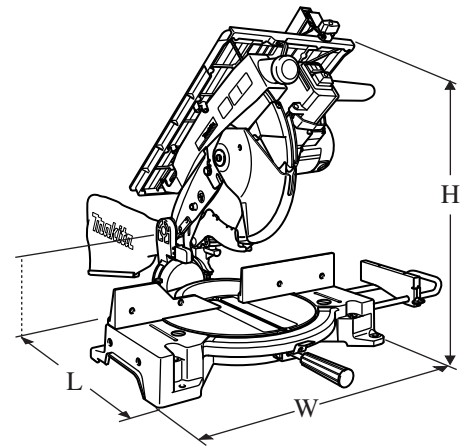

▶ Specification

Voltage (V)	Current (A)	Cycle (Hz)	Continuous Rating (W)		Max. Output(W)
			Input	Output	
110	15	50 / 60	1,650	1,000	2,300
120	15	50 / 60	1,650	1,000	2,300
220	7.9	50 / 60	1,650	1,000	2,300
230	7.5	50 / 60	1,650	1,000	2,300
240	7.2	50 / 60	1,650	1,000	2,300

Model No.	LH1040		LH1040F	
No load speed: min-1 = rpm.	4,800			
Saw blade: mm (")	Diameter	255 - 260 (10 - 10-1/4)		
	Hole diameter	15.88 (5/8) 30.0 (for European countries)		
Capacity: mm (") (with 260 mm saw)	Table saw	40 (1-9/16)		
	Miter saw	See the table below.		
Protection against electric shock	Double insulation			
Electric brake	Yes			
LED job light	No			Yes
Cord length: m (ft)	2.5 (8.2)			
Net weight: kg (lbs)	13.7 (30.2)			

Cutting capacity as Miter Saw

Bevel angle Miter angle	90°	45° Left bevel
90°	69mm x 130mm (2-3/4" x 5-1/8") 93mm x 95mm (3-5/8" x 3-3/4")	35mm x 130mm (1-3/8" x 5-1/8") 53mm x 95mm (2-1/16" x 3-3/4")
45° Left	69mm x 85mm (2-3/4" x 3-3/8") 93mm x 67mm (3-5/8" x 2-5/8")	35mm x 65mm (1-3/8" x 2-9/16") 49mm x 42mm (1-15/16" x 1-5/8")
45° Right	69mm x 85mm (2-3/4" x 3-3/8") 93mm x 67mm (3-5/8" x 2-5/8")	35mm x 91mm (1-3/8" x 3-5/8") 49mm x 67mm (1-15/16" x 2-5/8")

▶ Standard equipment

TCT saw blade 260mm	1 pc	Socket wrench 13	1 pc	Set plate	1 pc
Dust bag	1 pc	Ring 16 (adaptor for saw blades with 25mm hole diameter)	1 pc	Blade cover	1 pc
Holder set	1 pc	Triangular rule	1 pc	Push stick	1 pc
Sub plate ass'y	1 pc			Guide rule	1 pc

Note: The standard equipment listed above may differ from country to country.

▶ Optional accessories

Vertical vise	Holder set
Horizontal vise	Assorted TCT saw blades

► Repair

CAUTION: For your safety, before maintenance or repair, be sure to;

1. Disconnect the machine from the power source.
2. Remove the saw blade from the machine.

[1] NECESSARY REPAIRING TOOLS

Tool No./ Description	Use for
1R035/ Bearing Setting Plate 15.2	Press-fitting Ball bearings
1R045/ Gear Extractor (large)	Disassembling Gear housing cover and Bearing box
1R208/ 90 Degrees Set Square	Squaring Saw blade with Base
1R229/ 1/4" Hex shank bit for M5	Removal/Installation of screws that fasten Bearing box
1R235/ Round Bar for Arbor 6-100* (2 pcs)	Disassembling Blade case
1R269/ Bearing Extractor	Removing Ball bearings
1R291/ Retaining Ring S and R Pliers	Removal/Installation of the Retaining ring
1R306/ Ring Spring Removing Jig**	Disassembling Blade case
1R340/ Wrench for Bearing Retainer	Removal/Installation of Bearing retainer

***Note:** Disassembling can be done also using two Phillips screwdrivers of 6.5X100mm or larger size instead.

****Note:** Disassembling can be done also using 1R201/ Jig for Retaining Ring.

[2] LUBRICATION

- 1) Apply 12g of Makita grease N No.1 to the gear portion.
- 2) Apply an appropriate amount of Makita grease N No.1 to each of the listed below.
Although these slide surfaces are factory-greased with Makita grease N No.1, you apply other type of grease such as Makita grease N No.2 or the like.

Position No.	Parts item	Portion to be lubricated
1	Blade case	Gear portion
		Accepting hole for compression spring 27
		The pivotal portion where arm contacts
24	Center cover	The portion where torsion spring 36 contacts
99	Table support	The elliptic punched hole where lever 54 contacts, when table support is slidden up and down.
		The side where (1) Blade Case contacts, when table support is slidden up and down.
101	Support plate	The elliptic punched hole where pipe 9-126 contacts, when support plates are slidden up and down.

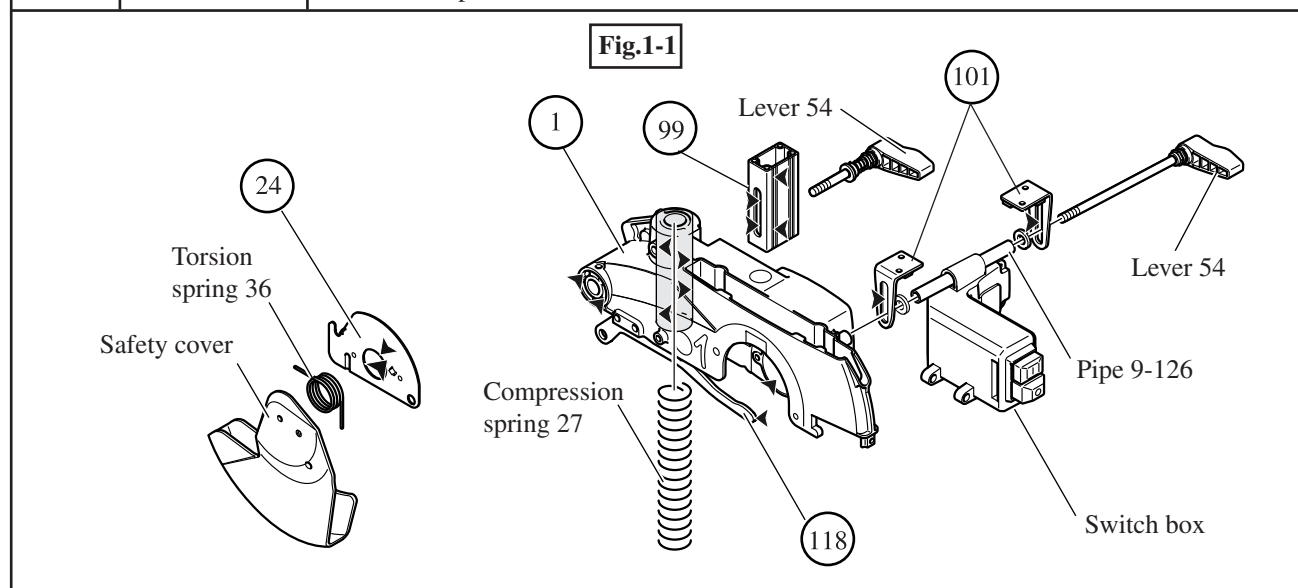

► **Repair**

[2] LUBRICATION

Position No.	Parts item	Portion to be lubricated
124	Hex bolt M10	Threaded portion
126	Rod 16	The surface where (127) Arm Complete contacts.
127	Arm complete	The portion where (145) turn base contacts, when arm complete pivoting.
		Accepting portion for pivoting (1) Blade Case
129	Stopper pin	The groove to which O ring 5 is mounted.
135	Slide plate	The surface where (145) turn base contacts
145	Turn base	Accepting portion for pivoting (127) Arm Complete
147	Base complete	Accepting boss for the shaft of (145) Turn Base
150	Knock spring	Both edge which contacts its accepting portion of (145) Turn Base
151	Grip 32	Tip of the threaded portion with which (150) Knock spring is pushed toward (145) Turn Base
A	Thumb screw	Tip of the threaded portion

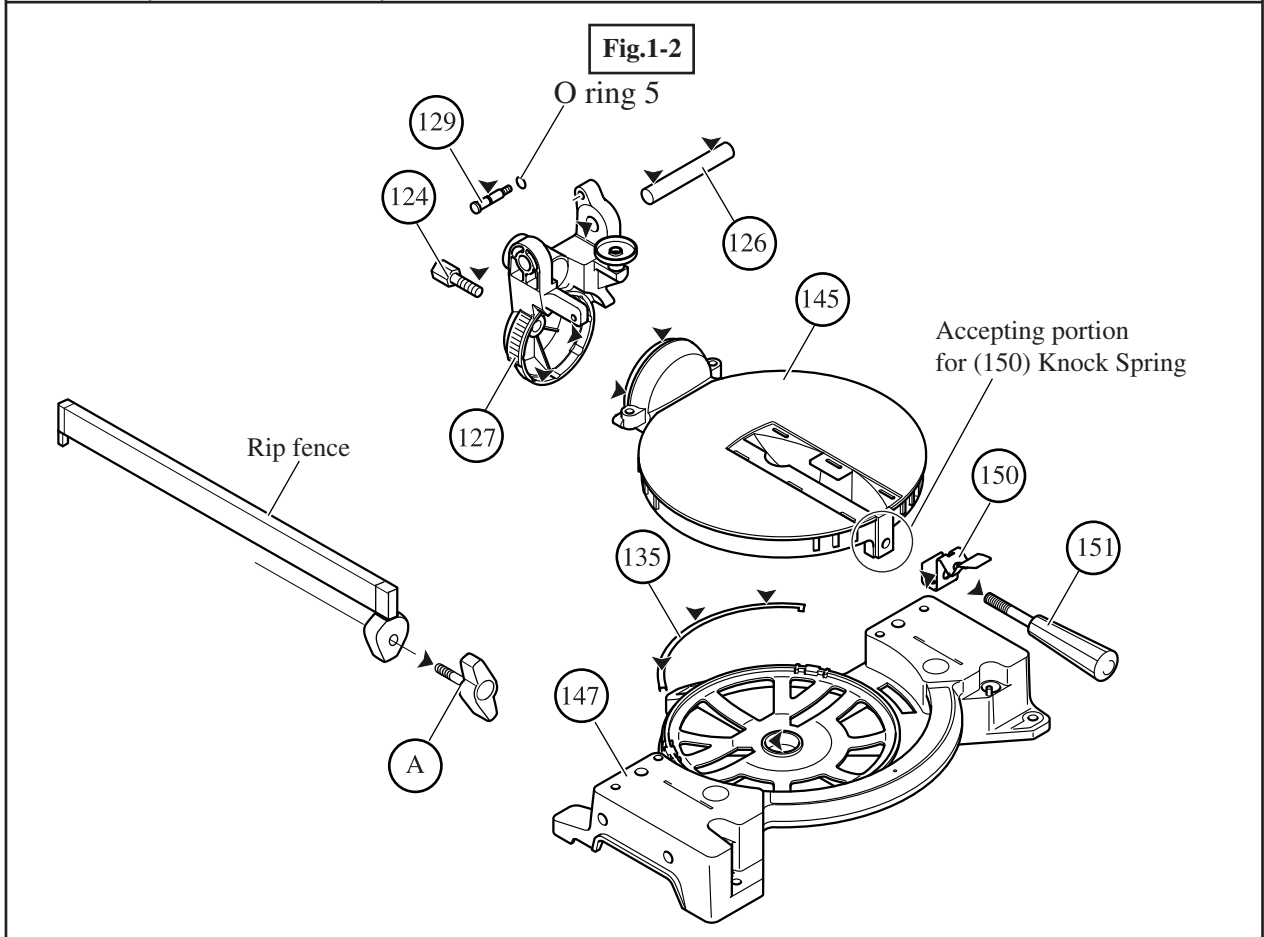

▶ Repair

< 3 > Removing table

1. Lift up table by loosening two 54 levers which are equipped under the table. See Fig.2-1.
2. Lift up the table to the highest level. See Fig.2-1.
3. Remove pan head screw M5x16 and remove cover complete from riving knife. See Fig.2-2.
4. Remove 8 M5x16 countersunk head screws. Then, table can be removed from blade case. See Fig.2-2.
And remove compression spring 27 from blade case. See Fig.2-2.
(In case of model LH1040 without fluorescent job light)
- 4A. While lifting up the table, remove light circuit from the table. Then, table can be removed from blade case.
And remove compression spring 27 from blade case. See Fig.2-2.
(In case of model LH1040F with fluorescent job light)

Fig.2-1

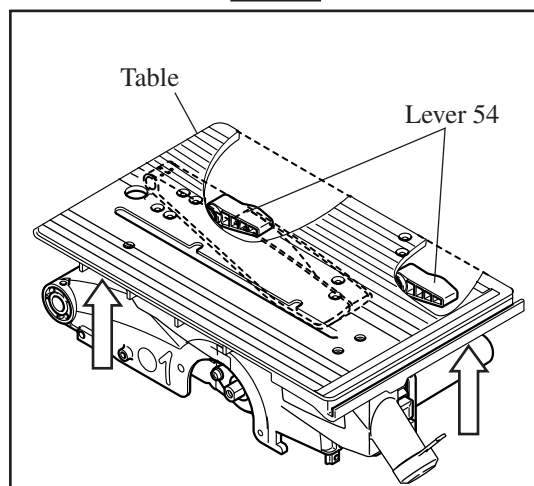
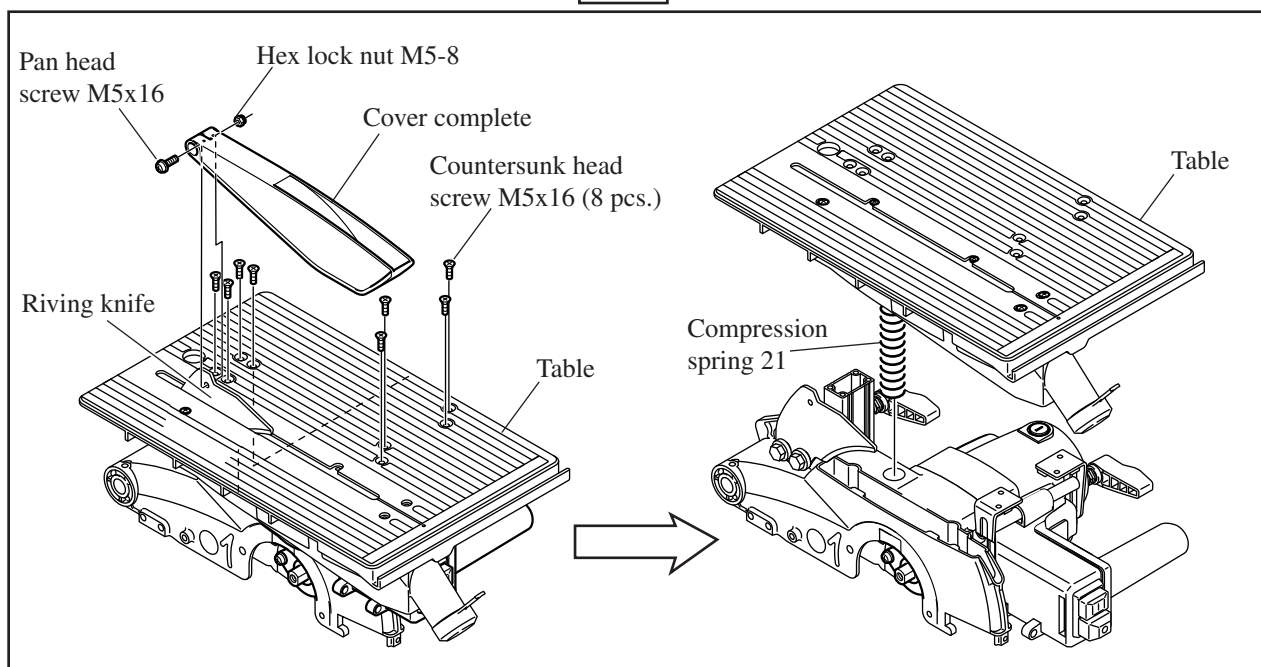

Fig.2-2



< 4 > Mounting table

1. Secure table with 8 M5x16 countersunk head screws. Refer to Fig.2-2.
2. While lifting up table to the highest level, mount compression spring 21 by inserting it from the side.
3. Take the left step with referring to the above Figs.

► Repair

< 5 > Removing blade case section

1. Remove living knife. See Fig.3-1.
2. Remove lever 54, support plate and pipe 9-126. See Fig.3-1.
The pipe 9-126 removed in this step, is used as a jig for removing rod 16 which functions as a pivot for blade case.
3. Loosen lever 54 and press table support down to the surface of blade case. See Fig.3-2.

Fig.3-1

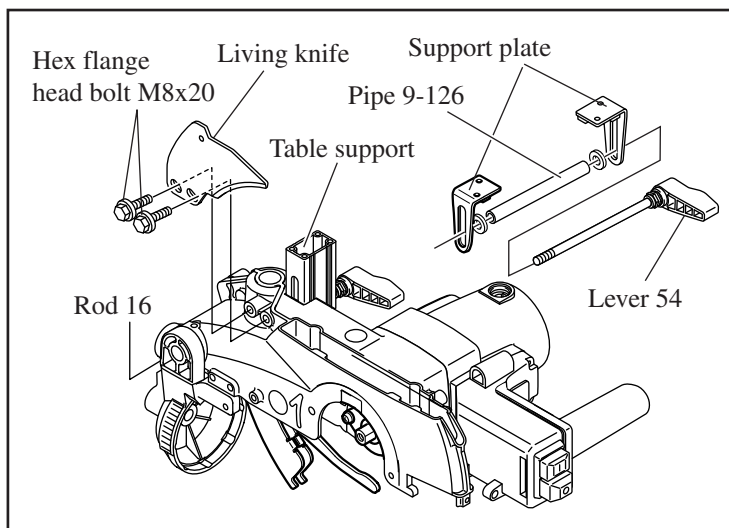
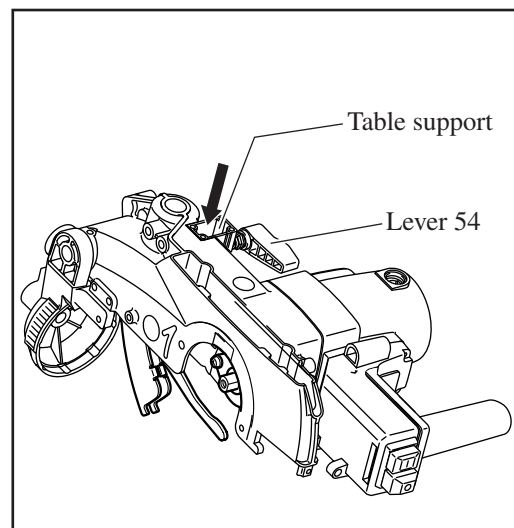

Fig.3-2



4. Remove two M5x16 pan head screws. Now guard with guard holder can be removed from blade case. See Fig.3-3.
5. Remove hex socket button head screw M6 (adhesive type), flat washer 7 and ring 7. Now the linkage of link plate with arm complete has been disconnected. See Fig.3-4.
6. Remove stop ring E-5, flat washer 6 and ring 6. then, link plate can be removed from blade case. See Fig.3-5.

Fig.3-3

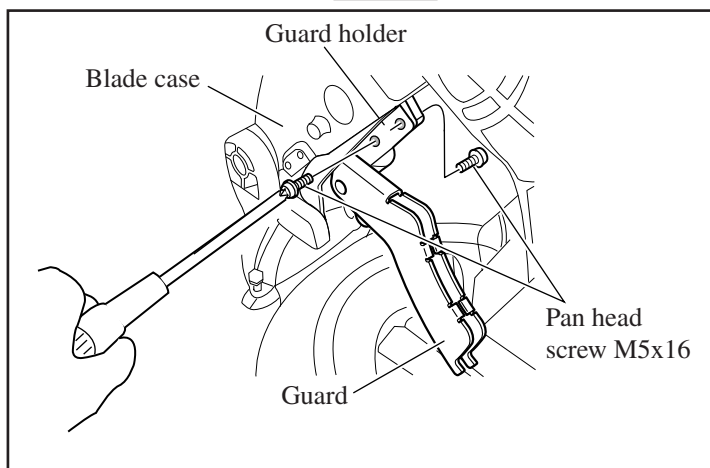

Fig.3-4

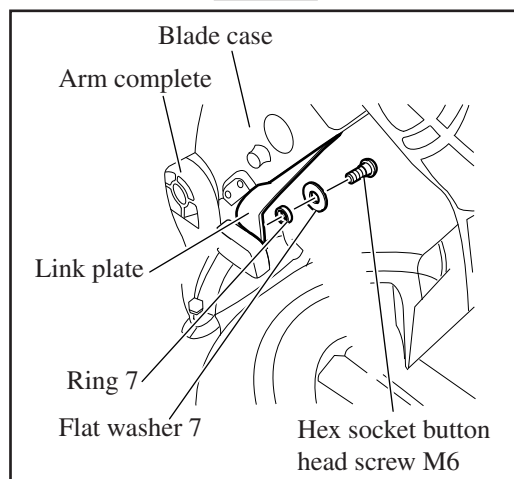
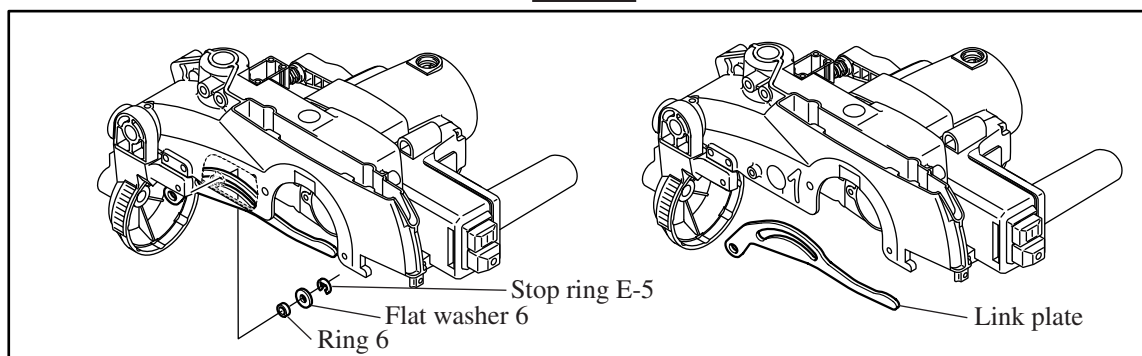

Fig.3-5



► Repair

< 5 > Removing blade case section

7. Lower the blade case section to the possible lowest position, and lock it at the same position with stopper pin. See Fig.3-6.
8. While further pressing the blade case section, insert two screwdrivers into the side hole of blade case. See Fig.3-7. Or insert No.1R238 "Round Bar for Arbor" as illustrated in Fig.3-7A.
9. Loosen hex socket head bolt M6x10 with hex wrench. See Fig.3-7.
10. Apply pipe 9-126 on rod 16, and remove it by striking the pipe with plastic hammer toward the side of hex socket head bolt M6x10. See Fig.3-8. Now blade case section can be separated from arm complete.

Fig.3-6

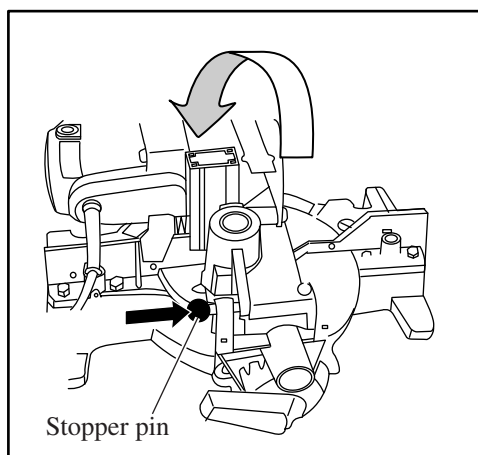

Fig.3-7

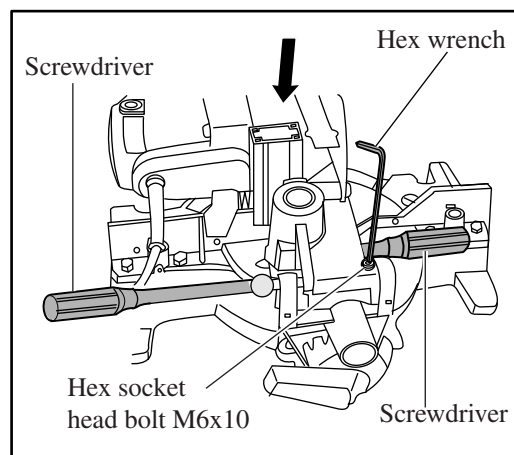

Fig.3-7A

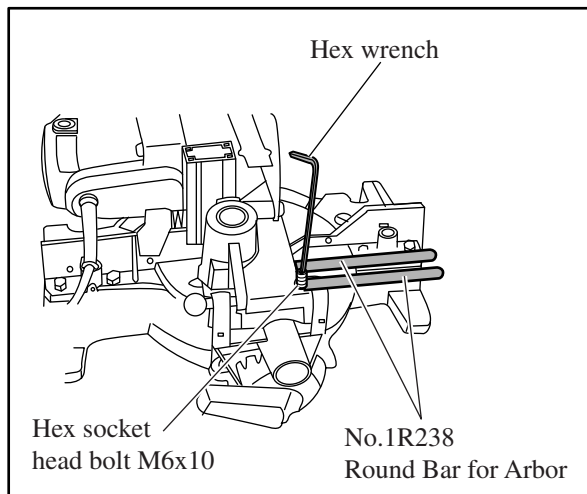
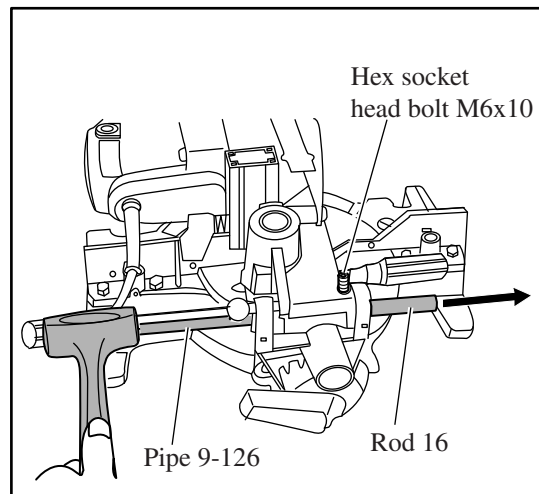

Fig.3-8



<Note>

In order to minimize scratch on the accepting holes for rod 16, remove it toward the side of hex socket head bolt M6x10. See Fig.3-8A.

Fig.3-8A

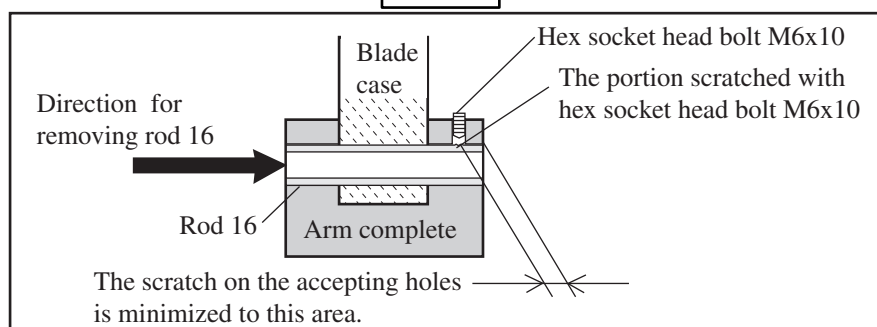

► Repair

< 5 > Removing blade case section

11. Put the removed blade case section on the turn base of arbor press, And set 1R306 "Ring Spring Removing Jig" between the two screwdrivers, inserted in the step of Fig.3-7. See Fig.3-9.
12. Press down 1R306 "Ring Spring Removing Jig" with arbor press. So, spring holder is pressed down and the screwdrivers can be pulled out from blade case.

Fig.3-9

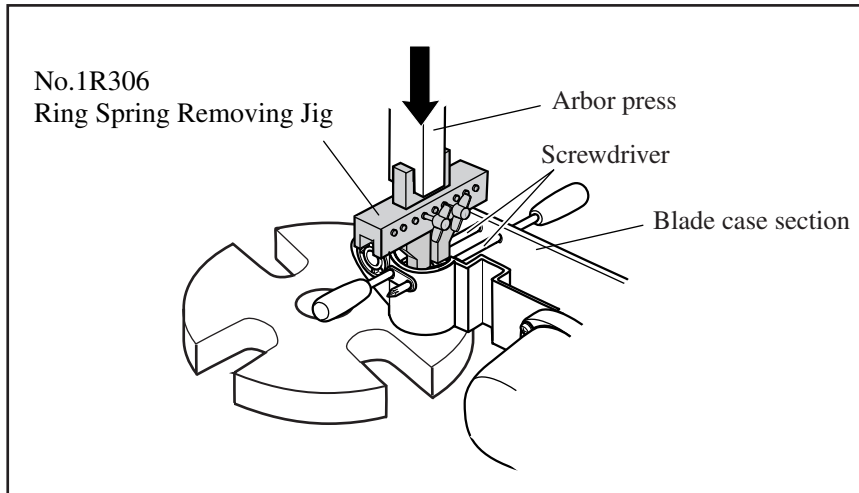

13. Put the removed blade case section on the turn base of arbor press, And set 1R306 "Ring Spring Removing Jig" between the two screwdrivers, inserted in the step of Fig.3-7. See Fig.3-9.
14. Press down 1R306 "Ring Spring Removing Jig" with arbor press in order to lower spring holder, while holding the blade case section firmly, so that it does not tilt or wobble.
15. Slowly lessen the pressure to 1R306 "Ring Spring Removing Jig", while holding the blade case section firmly, so that it does not tilt or wobble. See Fig.3-10.
16. Remove spring holder and compression spring 27 from blade case, when the jig gets free from the force of compression spring. See Fig.3-10.

Fig.3-10

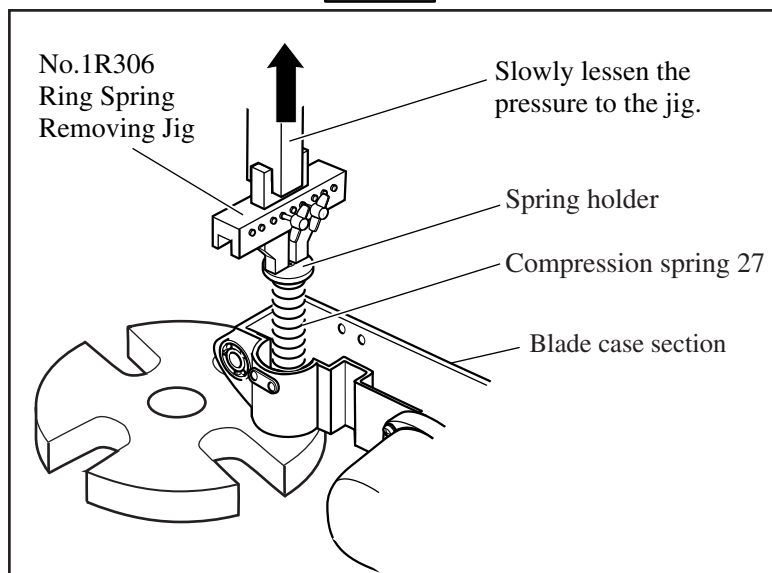

► Repair

< 5 > Mounting blade case section

1. Take the reverse step of removing, while paying attention to the following matters.
 - A. Scrape off the scratched portion of rod 16 with file, before mounting.
Mount rod 16 from the side of hex socket head bolt M6x10 . See Fig.4-1.
 - B. When pulling out two screwdrivers in the final step, press the blade case section down to the possible lowest position. Then, at the same time, spring holder is mounted to the original position automatically.
 - C. Apply the adhesive to hex socket button head screw M6 with which link plate is secured to arm complete.
Refer to Fig.3-4.

Fig.4-1

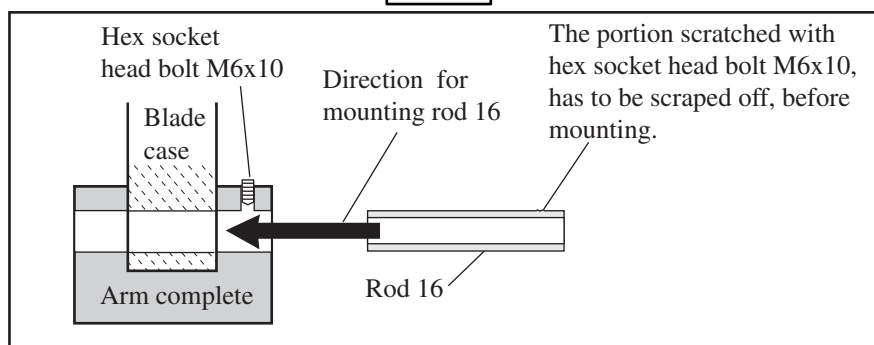

< 6 > Disassembling safety cover section

1. Loosen hex flange head bolt M8x12. Remove socket head flange screw M6 with hex wrench, inserted through the punched hole of safety cover. Now safety cover section can be separated from blade case. See Fig.5-1.
2. The safety cover section can be disassembled by unscrewing pan head screw M5x12. See Fig.5-2.

Fig.5-1

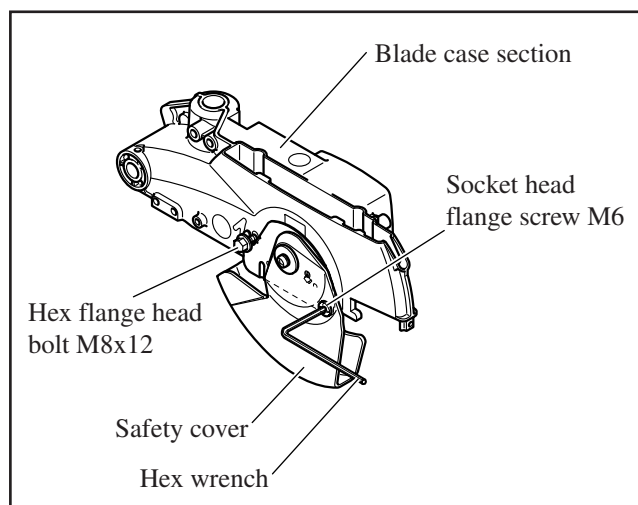
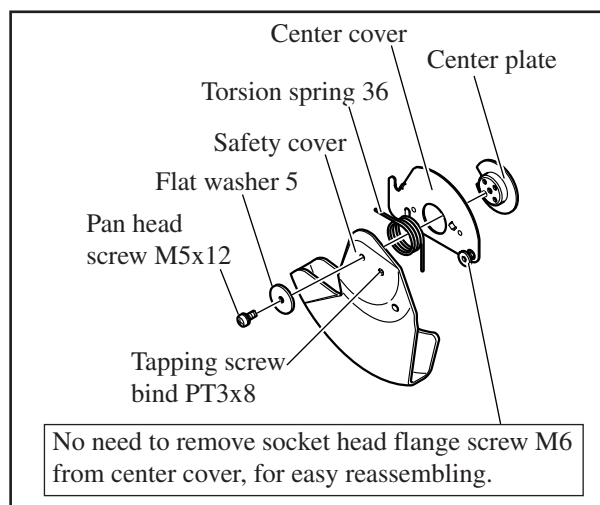

Fig.5-2



< 7 > Assembling safety cover section

1. In case of the disassembling as illustrated in Fig.5-2, tapping screw bind PT3x8 has to be removed from safety cover before reassembling.
2. Drive tapping screw bind PT3x8 again, after mounting torsion spring 36, center cover and center plate.
Refer to Fig.5-2.

► Repair

< 8 > Disassembling motor section

1. Remove carbon brush. See FIG.6-1.
And then, remove table from blade case section as illustrated in Fig.2-1 and Fig.2-2.
2. Remove lever 54 and support plate. See Fig.6-2.
3. After removing four M6x60 pan head screws, motor section can be separated from blade case. See Fig.6-3.

<Note>

Compression spring 9 for shaft lock falls off easily from the machine, when separating motor section from blade case. Be careful, not to lose this spring.

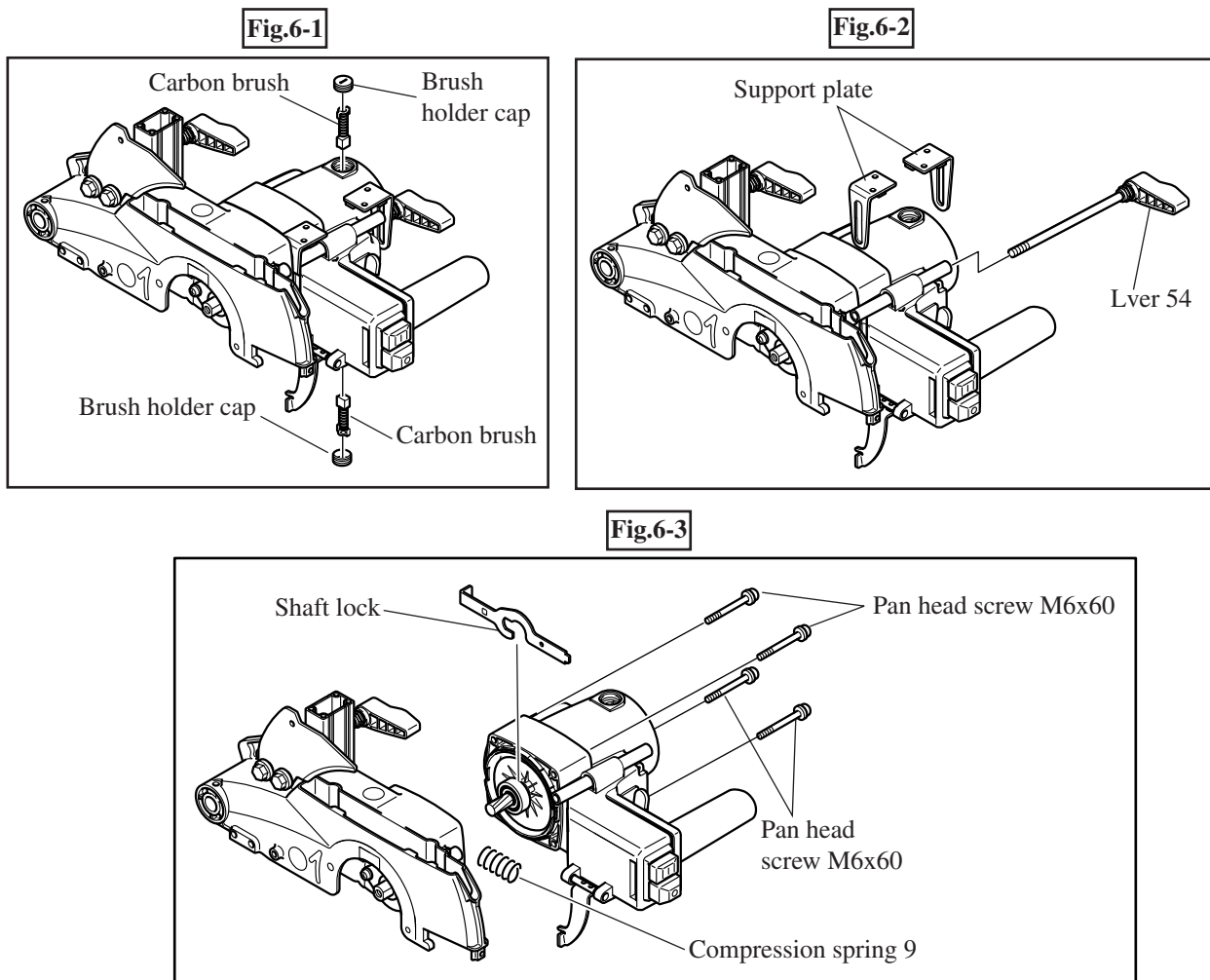

< 9 > Assembling motor section

1. Putting shaft lock into the notch of motor housing, mount armature to motor housing. See Fig.7-1.
2. While pushing shaft lock to the direction designated with black arrow, mount the motor section to blade case in order to avoid pching of shaft lock between motor housing and blade case. See Fig.7-2.
3. Take the reverse step of disassembling after the above process.

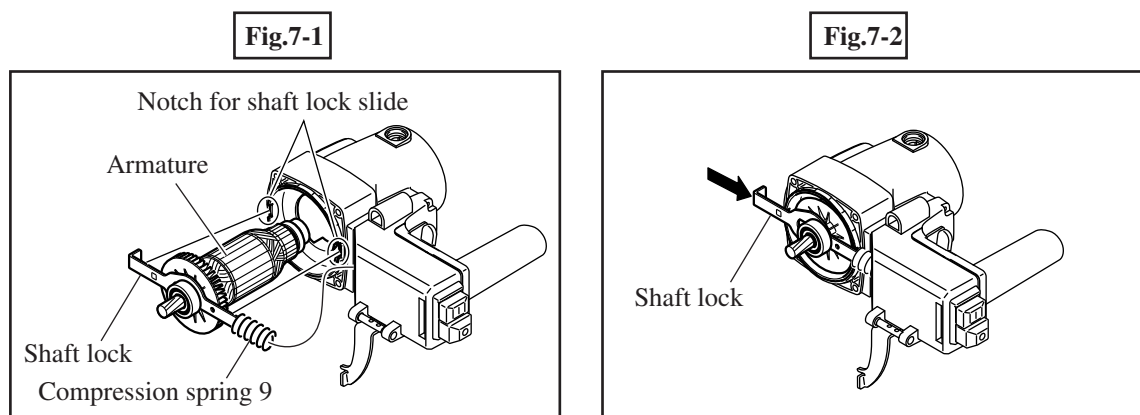

► Repair

< 10> Disassembling safety block mechanism

1. Lock the blade case section at the possible highest position, with stopper pin.
2. Remove lock lever by unscrewing 2 M4x10 pan head screws. Then, lock lever can be removed from lock pin. See Fig.8-1.
3. Remove motor section as shown in <8> Disassembling motor section, when removing lock pin 8. See Fig.8-2.

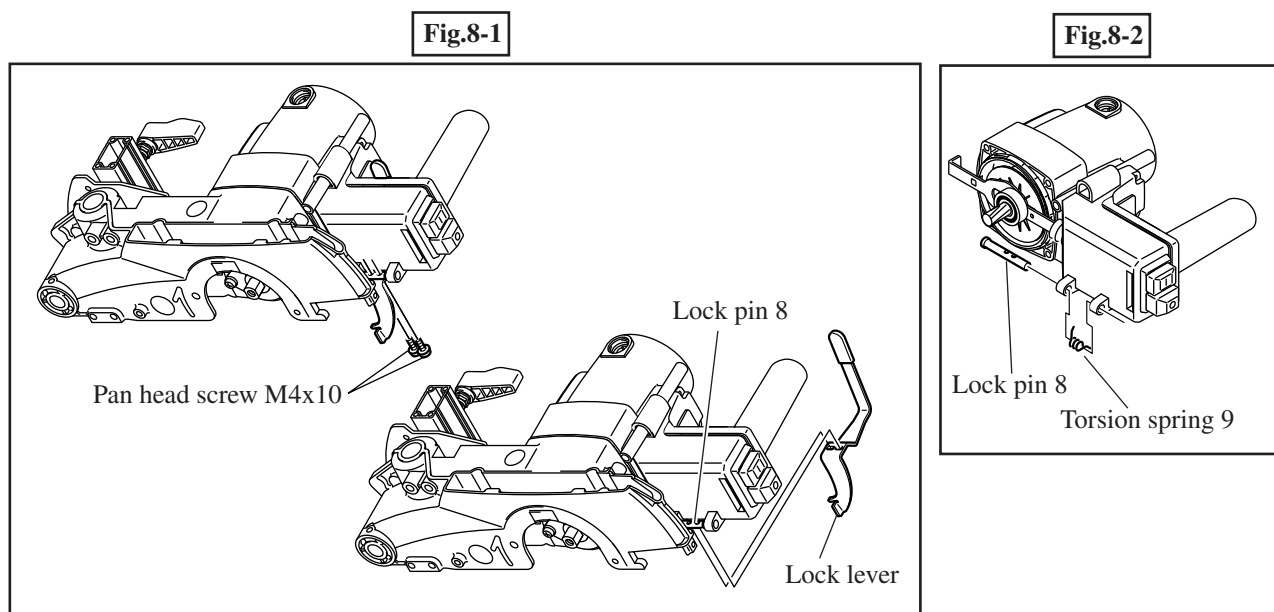

<11> Assembling safety block mechanism

1. Pass lock pin 8 through torsion spring 9, and hold its tail with switch box. See Fig.9-1.
2. While sliding lock lever to switch button side, tighten lock lever with one M4x10 pan head screw preliminarily. See Fig.9-2.
3. Nip the hooked tail of torsion spring 9 and put it on lock lever. See Fig.9-3.

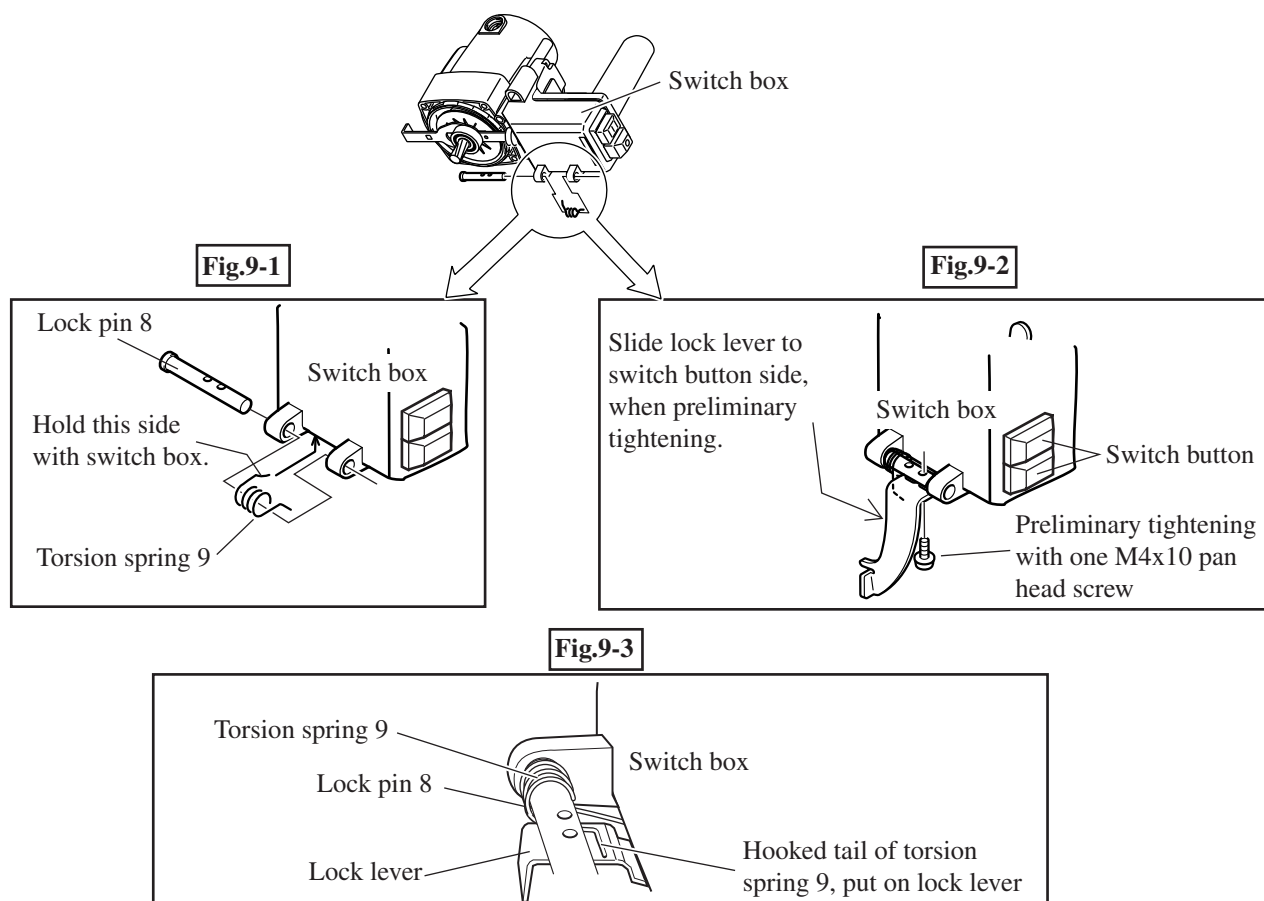

► Repair

<11> Assembling safety block mechanism

- Adjust the position of lock lever so that the distance between lock lever and safety cover is approx. 1mm. See Fig.9-4. And then, finally tighten lock lever with 2 Mx10 pan head screws.

Fig.9-4

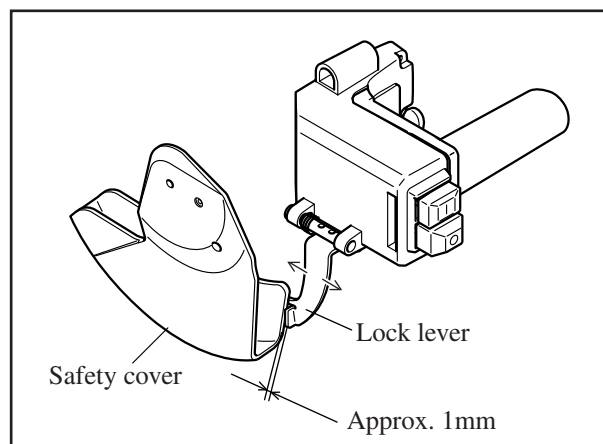

<12> Removing turn base

- Remove grip 32. From the bottom side of base, unscrew pan head screw M5x12. Now knock spring can be removed. See Fig.10-1.
- After removing guide fence, lever up kerf board with screwdriver to remove them. See Fig.10-2.
- Remove hex lock nut M8x13 and flat washer 8. Now turn base can be removed from base. See Fig.10-3.

Fig.10-1

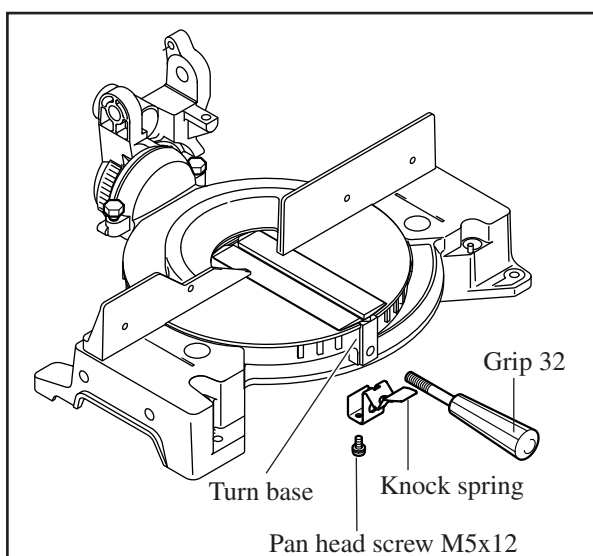
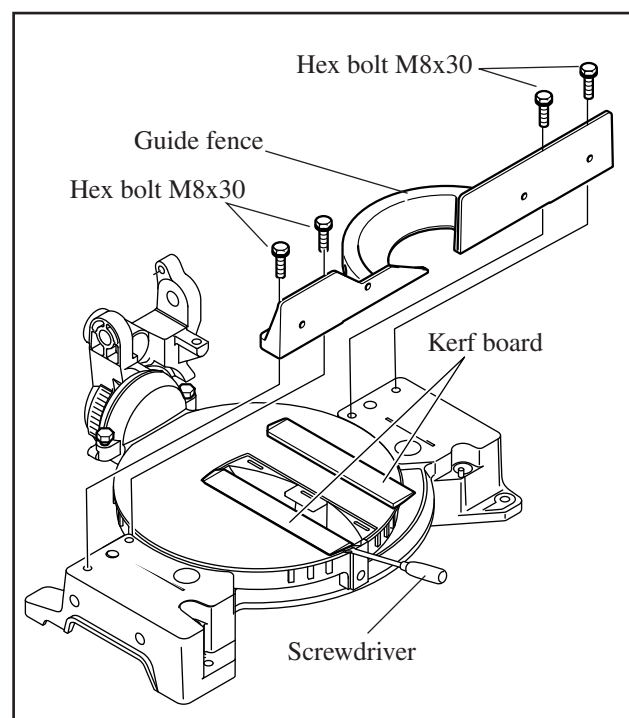

Fig.10-2



► Repair

<12> Removing turn base

3. Remove hex lock nut M8x13 and flat washer 8. Now turn base can be removed from base. See Fig.10-3.

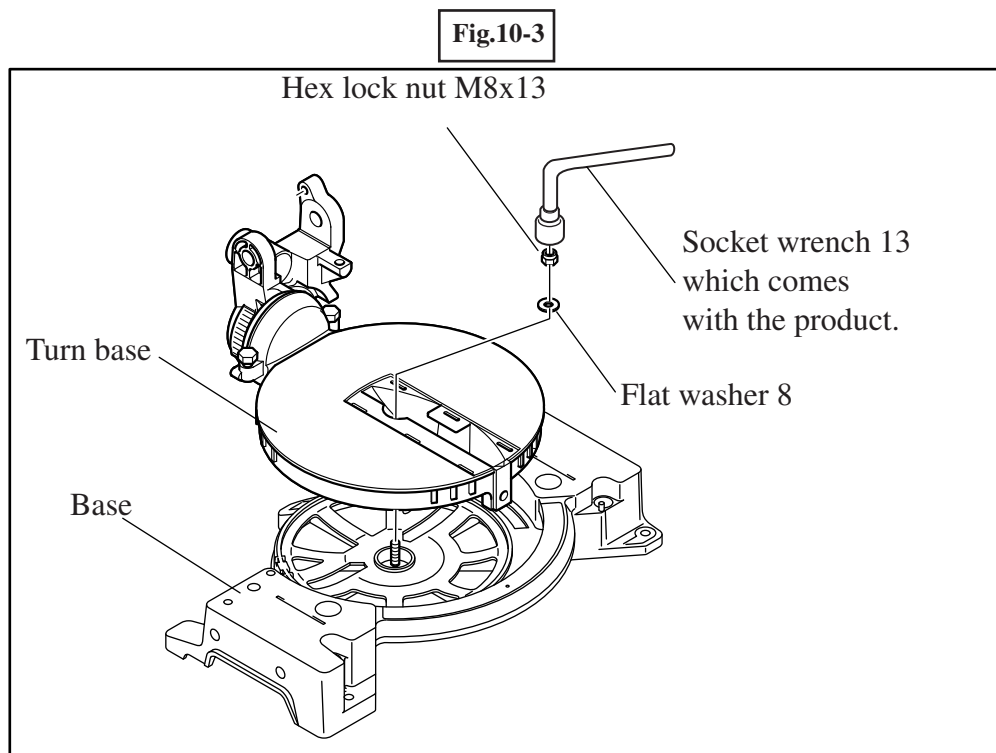

<13> Mounting turn base

1. Mount turn base and flat washer 8, and tighten hex lock nut M8x13 with socket wrench 13. The hex lock nut M8x13 has to be so tightened, that turn base can move without wobbling.
2. Take the reverse step of disassembling after the above process.

<14> Angle adjustment of saw blade

1. Adjusting to 90° to turn base,
While applying 1R208 "90-degree Set Square", turn Hex bolt M8x28 of motor housing side, until both saw blade and turn base contact the jig closely. See Fig.11-1.
2. Adjusting to 45° to turn base,
While applying 1R207 "45-degree Set Square", turn Hex bolt M8x28 of saw blade side, until both saw blade and turn base contact the jig closely. See Fig.11-2.

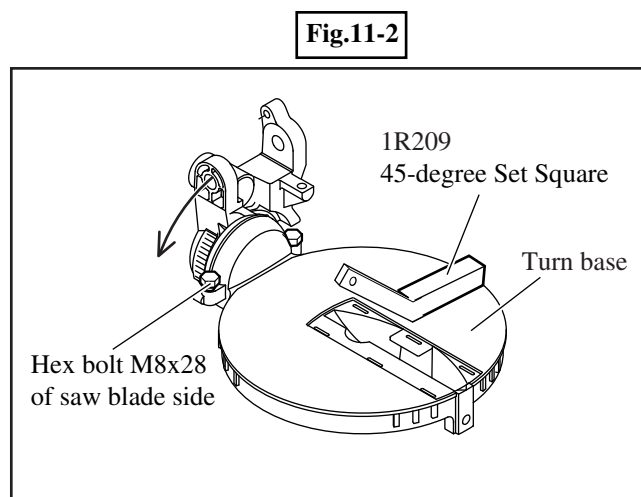
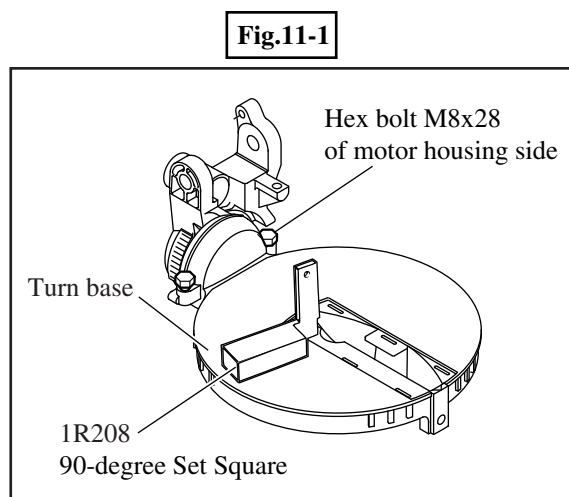

► Repair

<15> Squaring adjustment of guide fence

1. Set the bevel angle 90°.
2. Provisionally tighten M8x30 hex bolt (B) into the smaller screw hole on the left side of guide fence when viewed from operator's position.
3. While checking the angle of guide rule to saw blade using 90 Degrees set square (No.1R208), pivot the guide fence by moving its right end until the angle is 90 degrees.
4. After completion of squaring adjustment, securely tighten four M8x30 hex bolts; first A and D, then B and C.

Fig.12-1

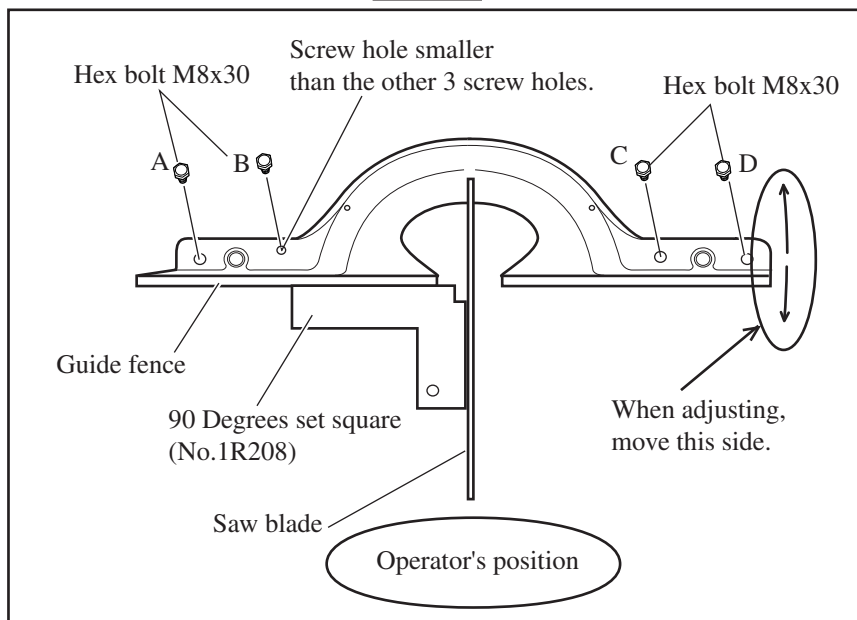

<16> Repairing switch section

Handle cover can not be separated from switch box without removing lock lever of safety lock mechanism. Remove lock lever as illustrated in Fig.8-1.

1. Remove handle cover, Now relay can be replaced. See Fig.13-1.

Fig.13-1

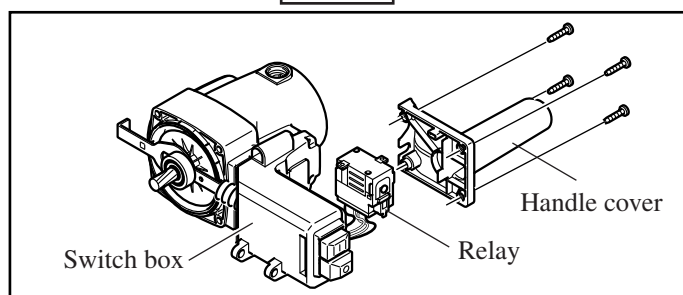

2. Do not forget to mount **clamp plate** and **felt ring 6**, when assembling switch section. And do not remove **sponge sheet** from handle cover, when mounting it to switch box. Because these three parts protect the machine against saw dust. See Fig.13-2.



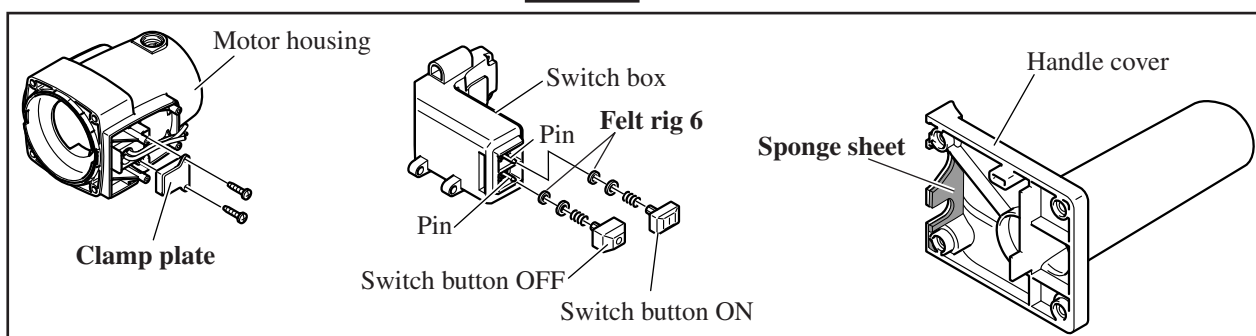





Fig.13-2



▶ Circuit diagram

(1) LH1040F with fluorescent job light for

- * High voltage area in Europe,
- * High voltage area in Saudi Arabia
- * Cyprus
- * Kuwait
- * Bhutan

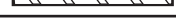
Color index of lead wires' sheath			
Black		Blue	
White		Purple	
Red		Brown	
Yellow		Gray	
Orange			

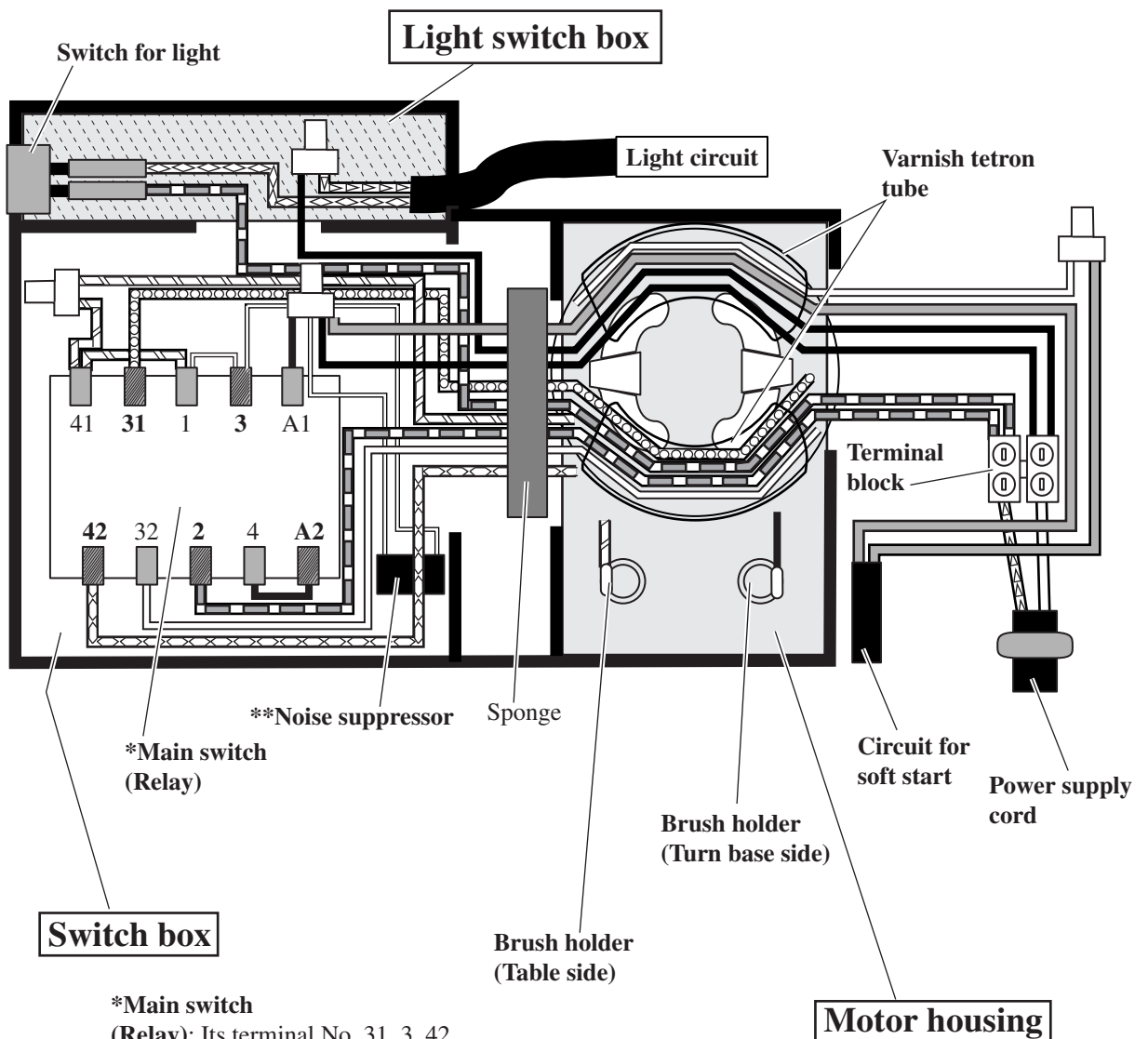

***Main switch (Relay):** Its terminal No. 31, 3, 42, 2 and A2 are equipped with receptacle sleeves.

****Noise suppressor:** The product is supplied without equipping noise suppressor for some countries.

► **Circuit diagram**

(2) LH1040F with fluorescent job light
for Low voltage in Great Britain



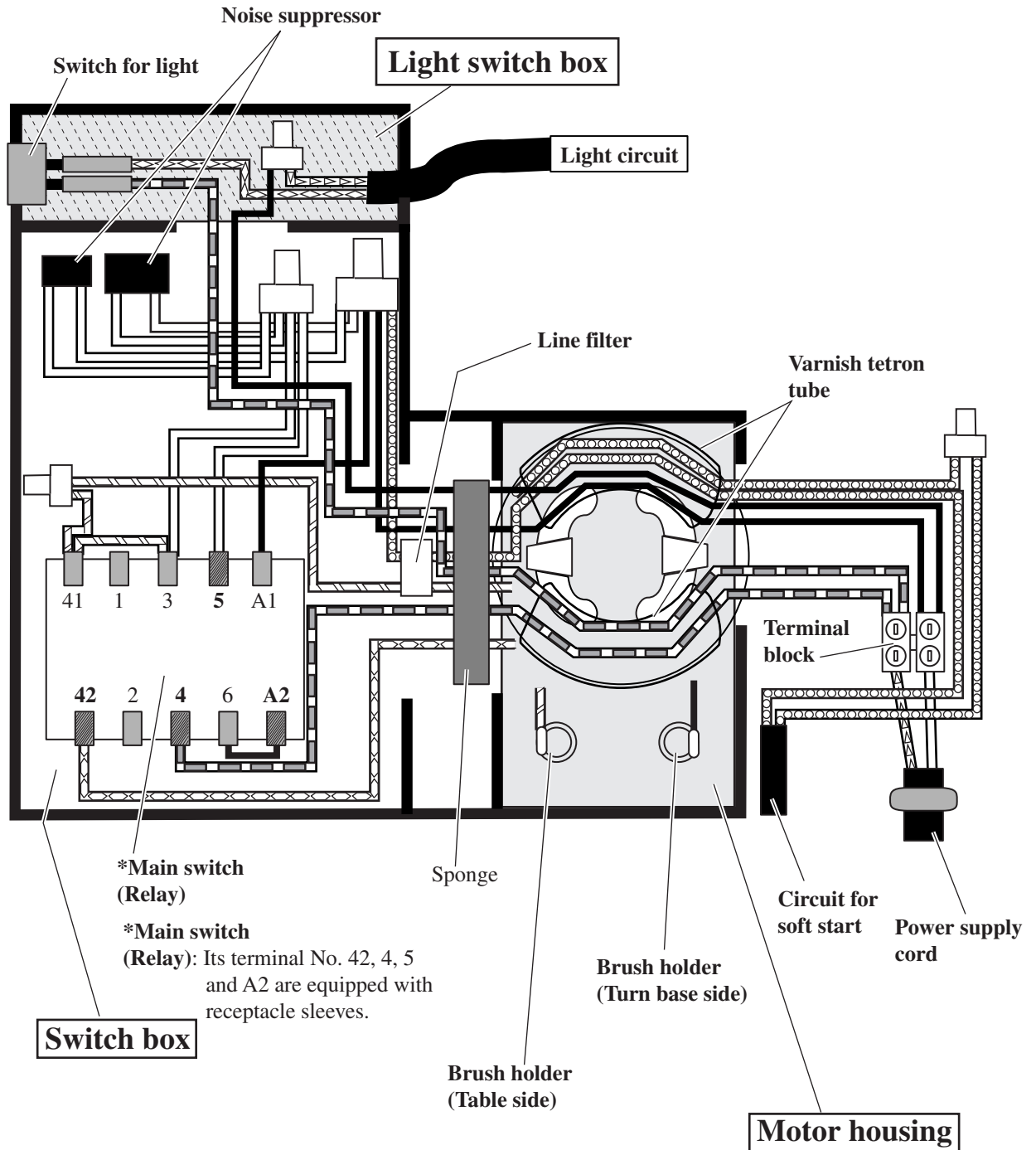



Color index of lead wires' sheath			
Black		Blue	
White		Purple	
Red		Brown	
Orange		Yellow	

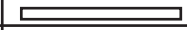

► **Circuit diagram**

(1) LH1040 without fluorescent job light, for

- * High voltage area in Europe,
- * High voltage area in Saudi Arabia
- * Cyprus
- * Kuwait
- * Bhutan

Color index of lead wires' sheath			
Black		Orange	
White		Purple	
Red		Gray	
Yellow			

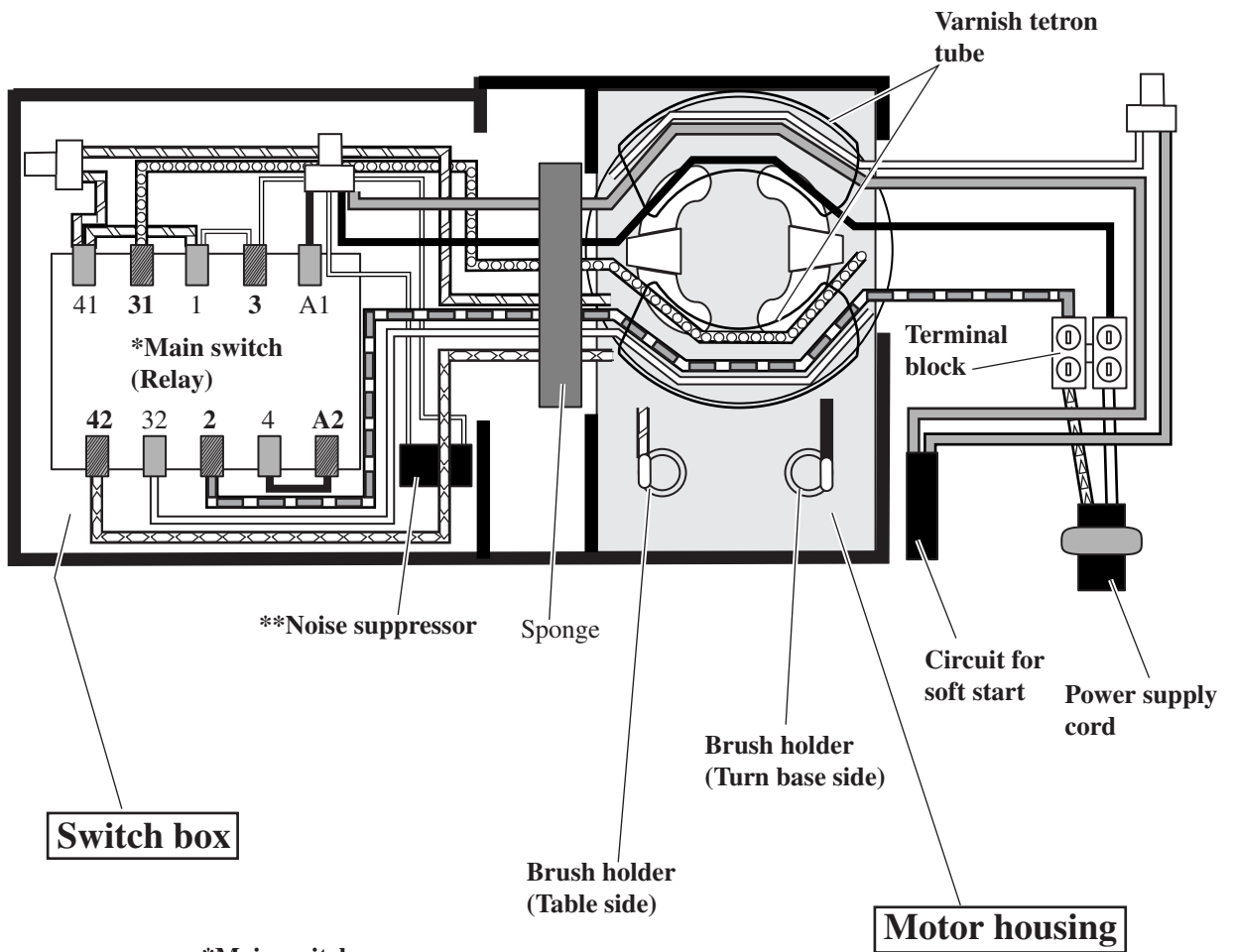









***Main switch**

(Relay): Its terminal No. 31, 3, 42, 2 and A2 are equipped with receptacle sleeves.

****Noise suppressor:** The product is supplied without equipping noise suppressor for some countries.

► **Circuit diagram**

**(2) LH1040 without fluorescent job light
for Low voltage in Great Britain**

Color index of lead wires' sheath			
Black		Blue	
White		Purple	
Red		Brown	
Orange		Yellow	

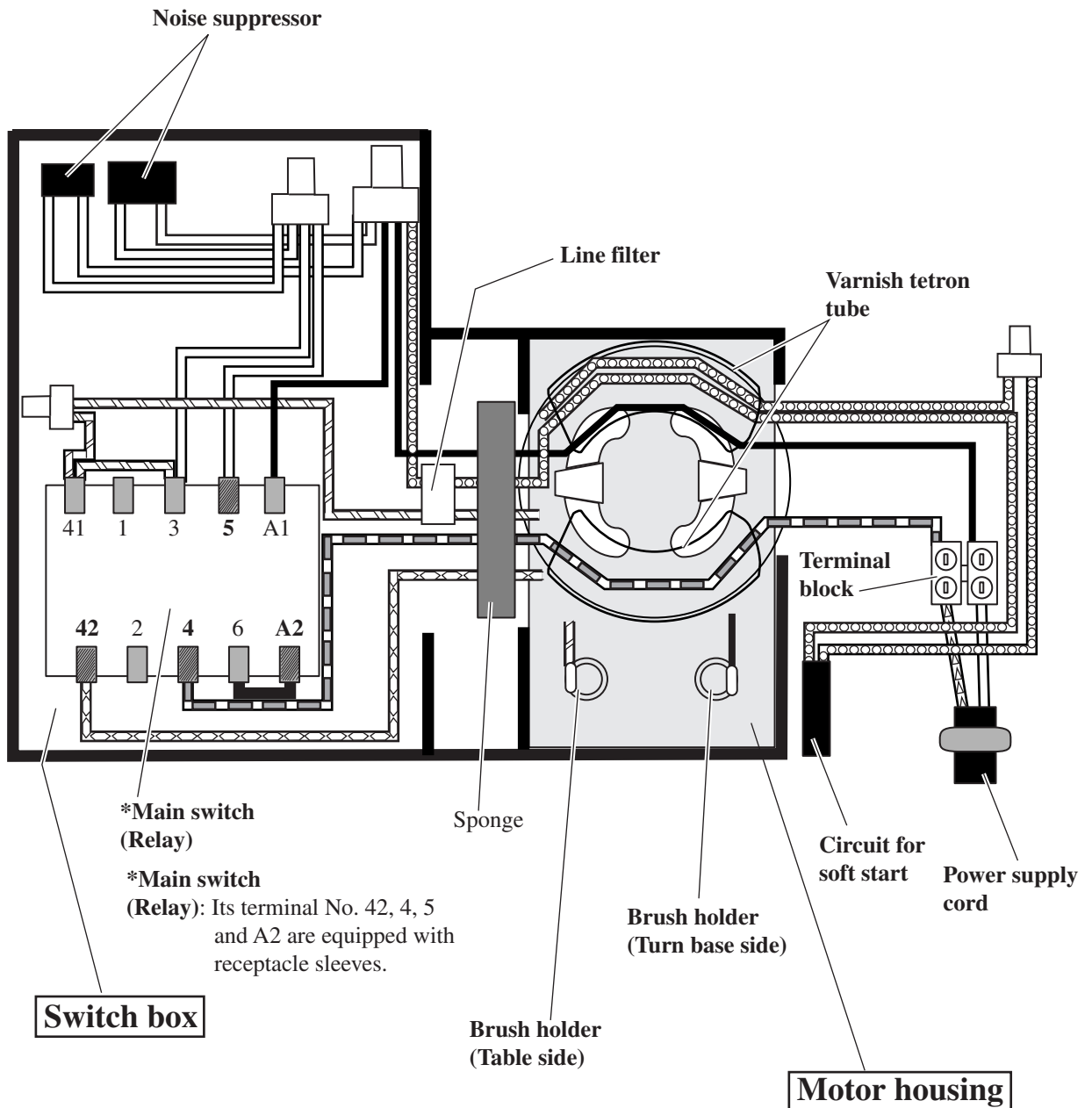

► **Wiring diagram**

under Housing Cover

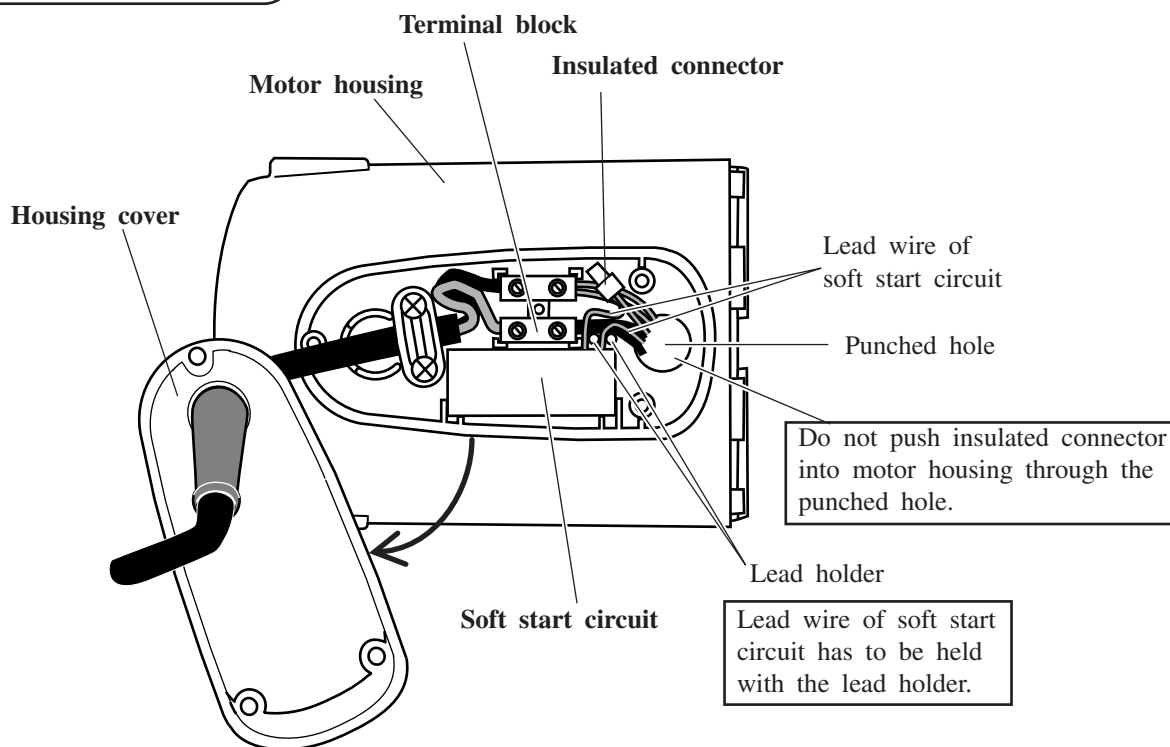

Motor housing

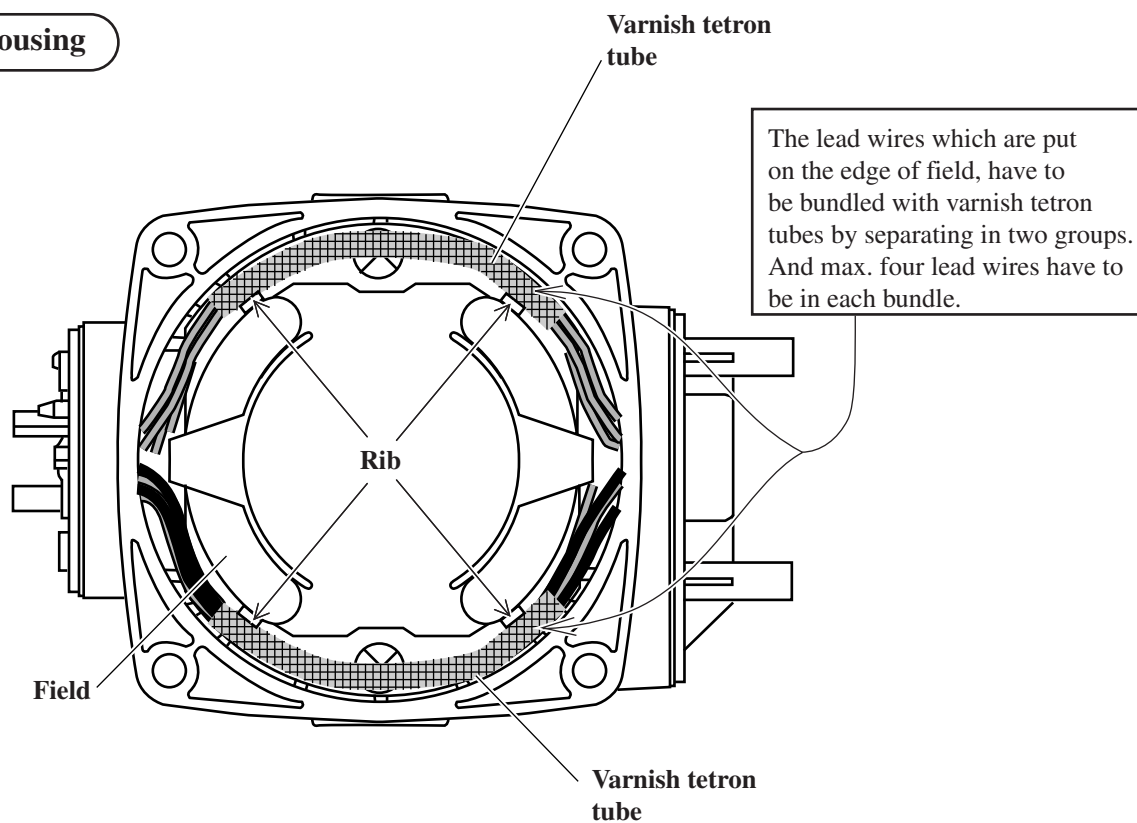

▶ Wiring diagram

Under clamp plate

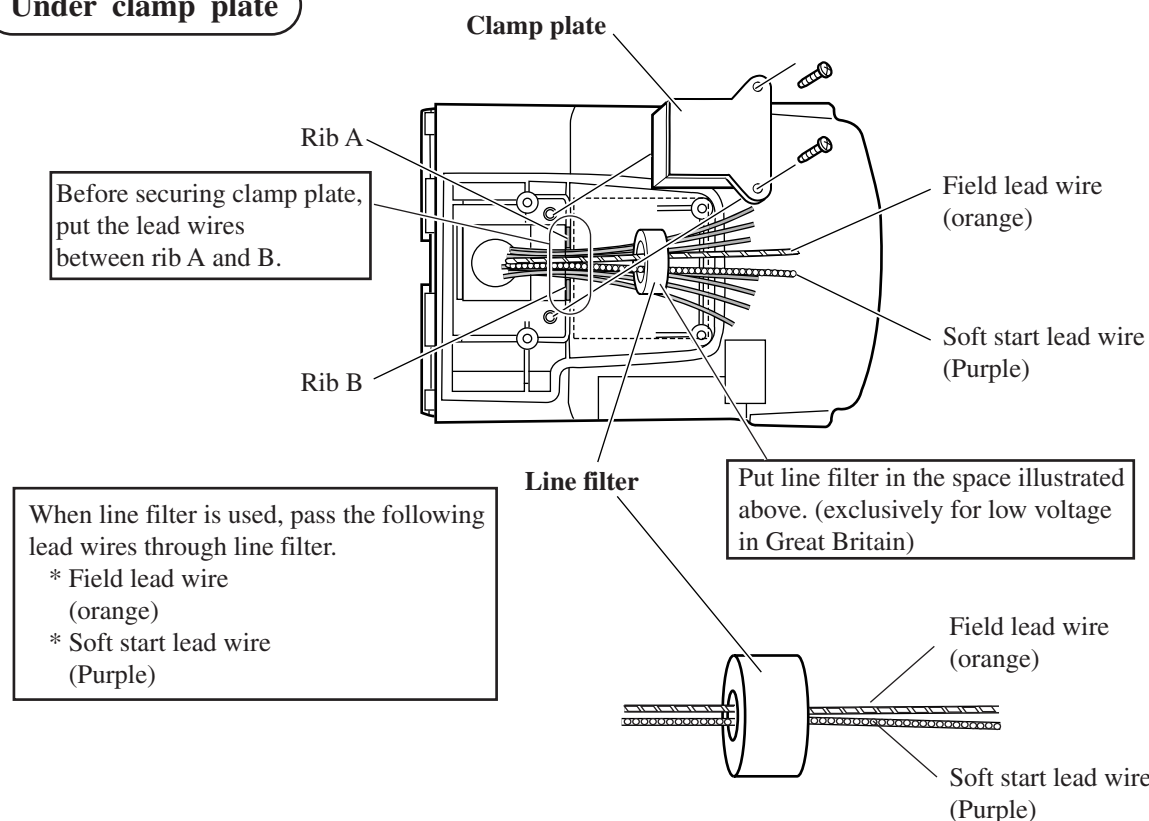

In switch box

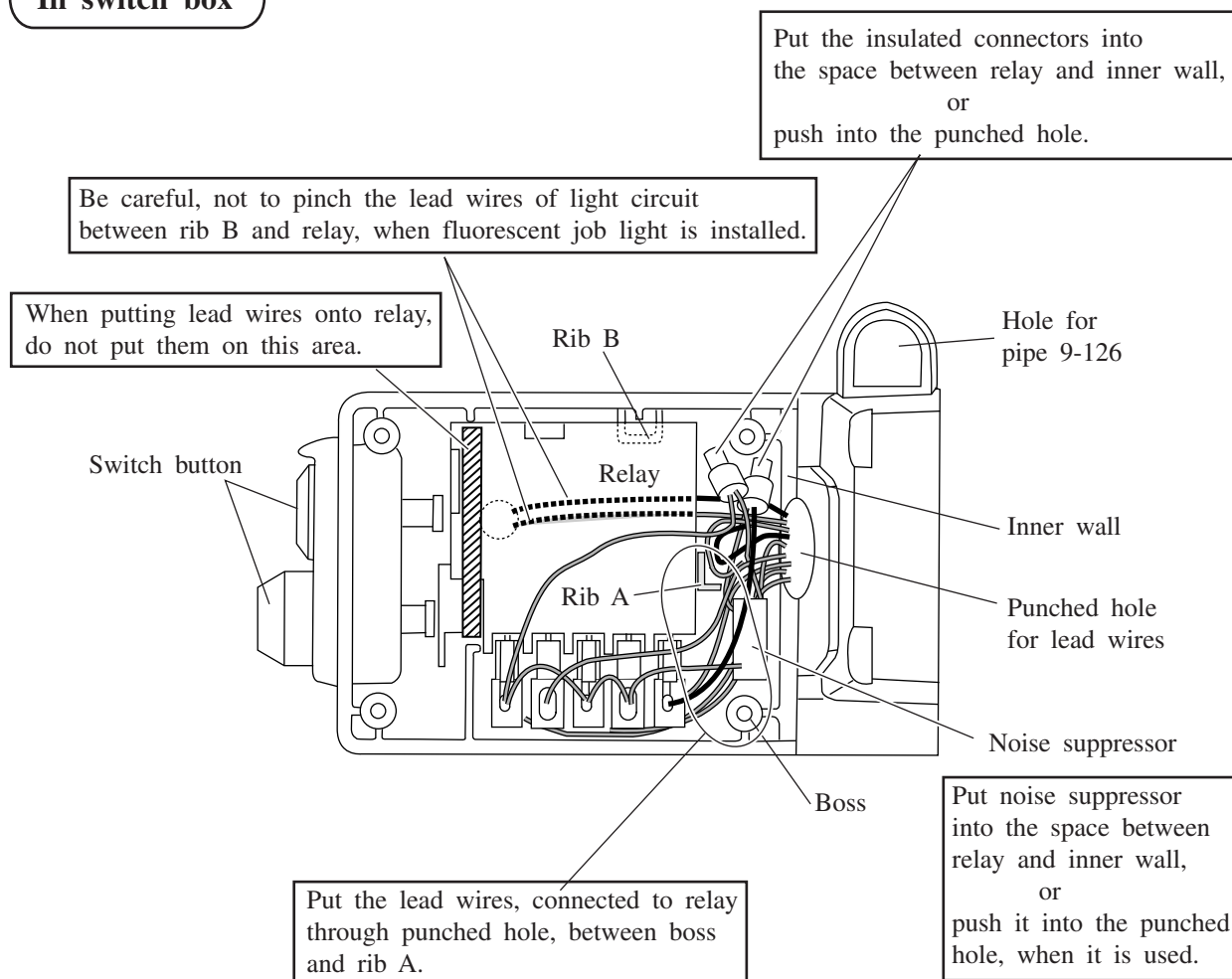

▶ **Wiring diagram**

Light Switch Box

