

[Skip to content](#)

Manuals+

User Manuals Simplified.



MI Electric Scooter Pro User Manual

Home » [Mi](#) » MI Electric Scooter Pro User Manual 

Contents [[hide](#)]

1 Mi Electric Scooter Pro User Manual

1.1 Package Contents

1.2 Product Overview

1.3 Assembly and Set-Up

1.4 Charge Your Scooter

1.5 Connect with Mi Home / Xiaomi Home App

1.6 How To Ride

1.7 Safety Reminder Watch out for safety risks.

1.8 Folding and Carrying

1.9 Daily Care and Maintenance

1.10 Specifications

1.11 Trademark and Legal Statement

1.12 Certifications

1.13 File Downloads

1.14 References

1.15 Related Manuals

Mi Electric Scooter Pro User Manual

Thank you for purchasing Mi Electric Scooter Pro. It is a sports and recreational vehicle with style.

Package Contents

Assembled Electric Scooter

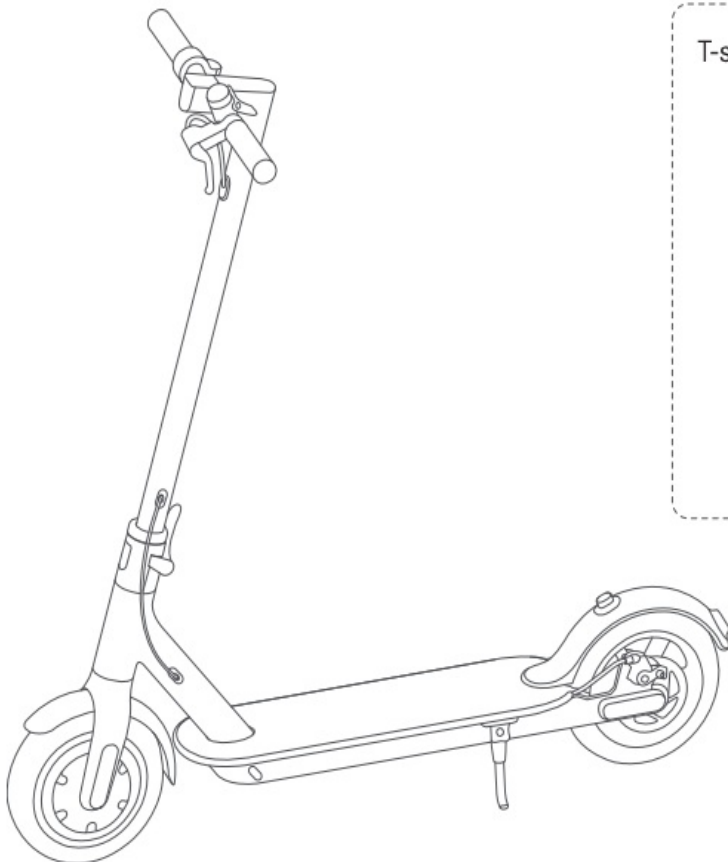

Accessories

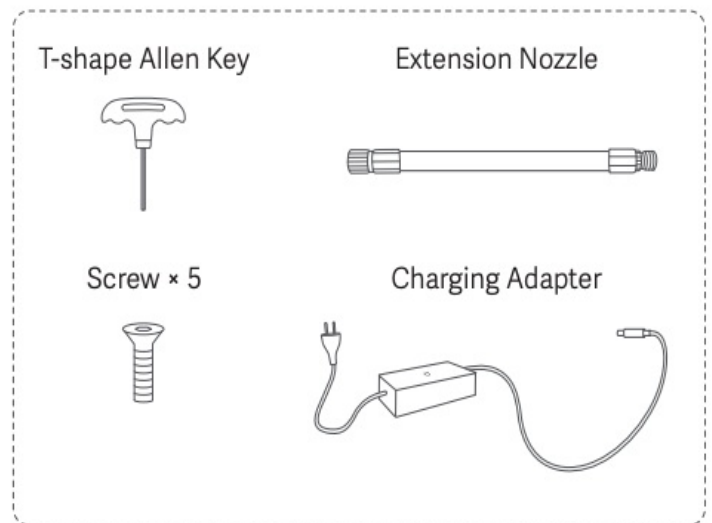

User Manual



Legal Statement



Warranty Notice



Maintenance Card



Quick Start Guide



Carefully check the package contents, if anything is missing or damaged, please contact the local customer service for support.

Product Overview

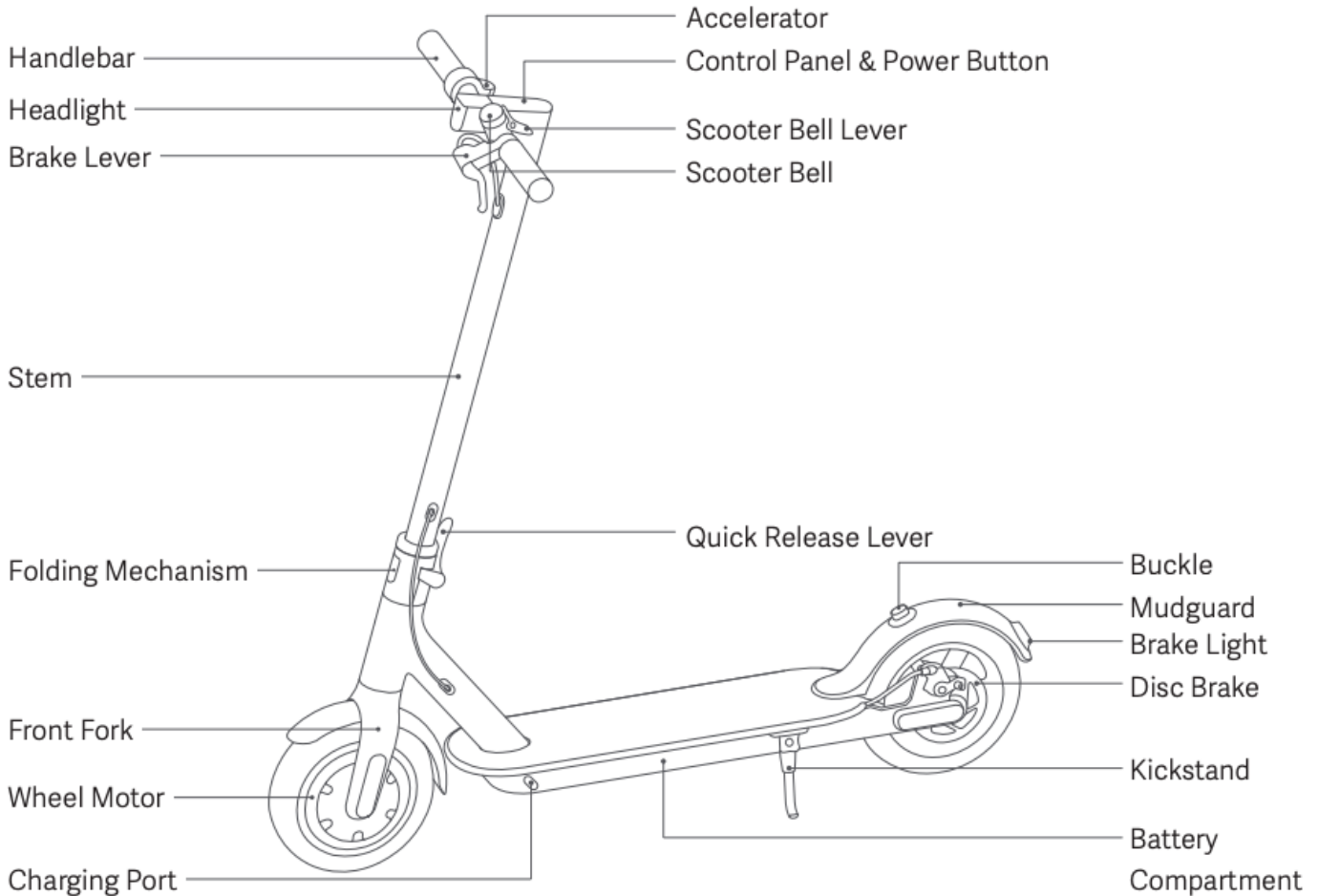

Control Panel & Power Button

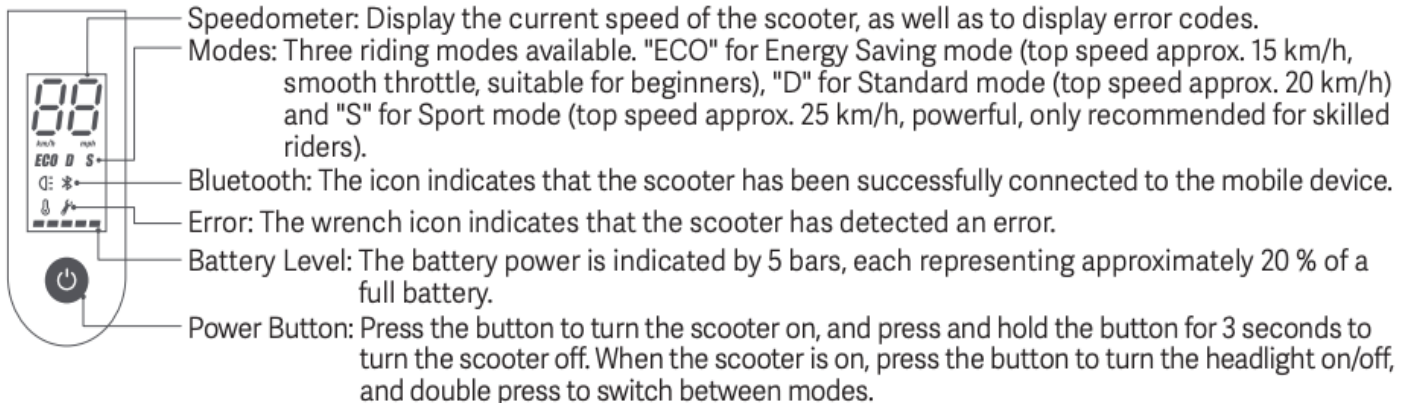

Assembly and Set-Up

1. Fold the handlebar stem up, fasten it, and put down the kickstand.

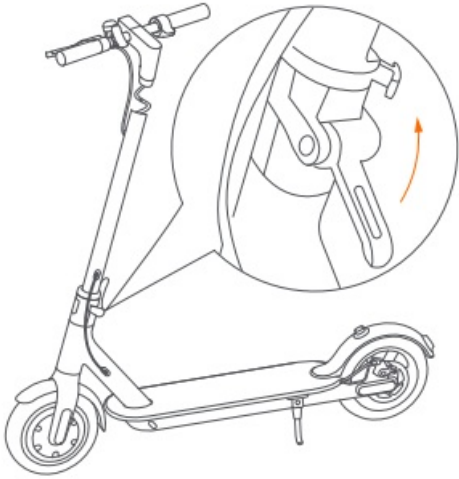

2. Install the handlebar onto the stem.

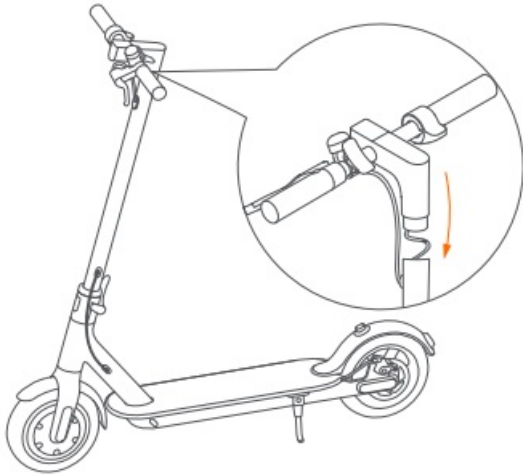

3. Tighten the screws onto both sides of the stem with the T-shaped Allen key.

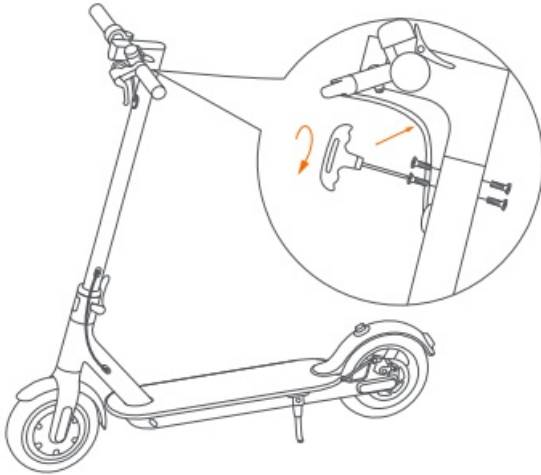

4. After the assembly, press the power button to check if it's working properly.

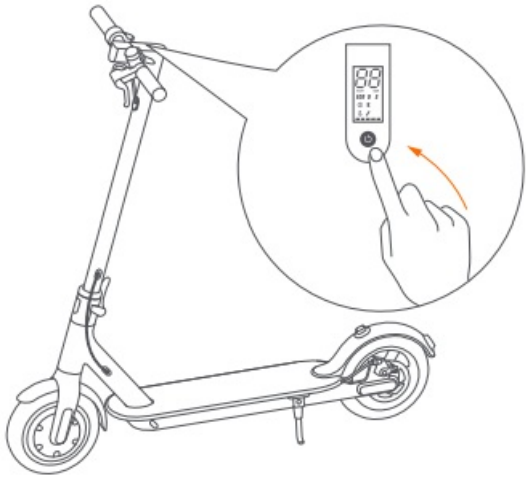

Charge Your Scooter

Charging condition description:

The scooter is fully charged when the LED on the charger changes from red (charging) to green (trickle charge).

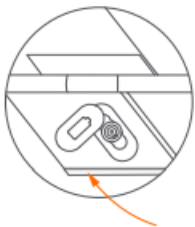
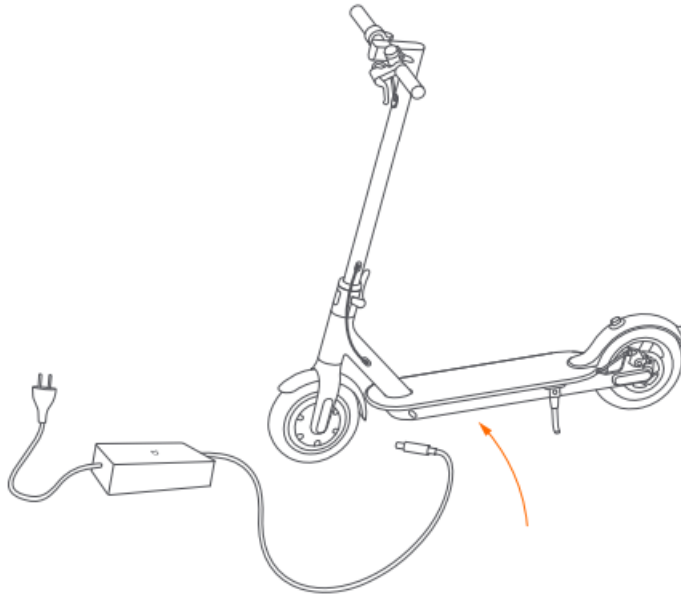

Lift up the rubber flap.



Plug the charging adapter into the charging port.



When charging is completed, put back the rubber flap.

Connect with Mi Home / Xiaomi Home App

This product works with Mi Home / Xiaomi Home app*. Control your device with Mi Home / Xiaomi Home app.

Scan the QR code to download and install the app. You will be directed to the connection setup page if the app is installed already. Or search “Mi Home / Xiaomi Home” in the app Store to download and install it.

Open Mi Home / Xiaomi Home app, tap “+” on the upper right, and then follow prompts to add your device.

* The app is referred to as Xiaomi Home app in Europe (except for Russia). The name of the app displayed on your device should be taken as the default.



Note: The version of the app might have been updated, please follow the instructions based on the current app version.

How To Ride

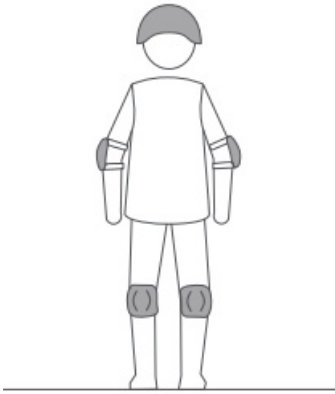

Warning: Wear a helmet, elbow pads and knee pads. Please read the instruction carefully before using. Do not touch the brake system. Refer to the instruction for more information.

1. Turn on the scooter, and check the power indicator.

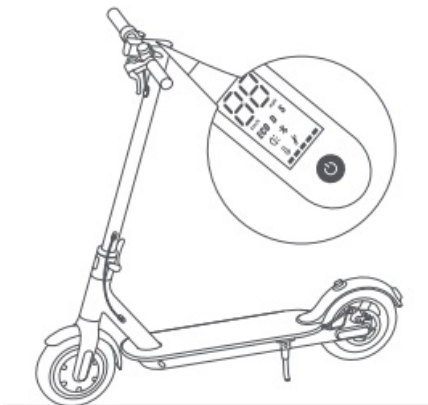

2. Step on the deck with one foot, and slowly kicks off the other on the ground. When the scooter starts to coast, put both feet on the deck and press the accelerator. Note: The accelerator initiates once the coasting speed exceeds 5 km/h.



3. When the scooter is at a full stop, the accelerator automatically turns off. To restart the scooter, it is necessary to repeat step 2.

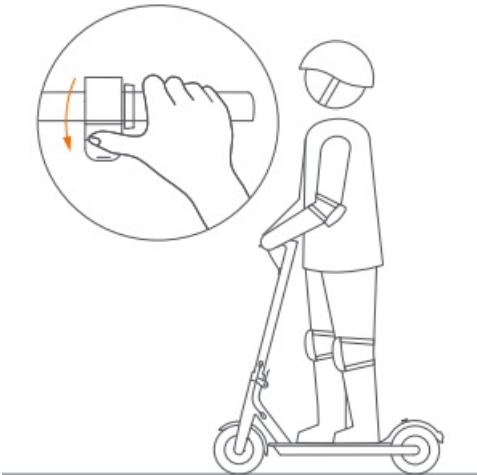

4. Release the accelerator and the kinetic energy recovery system (KERS) initiates automatically to brake slowly; squeeze the brake lever for a sudden brake.

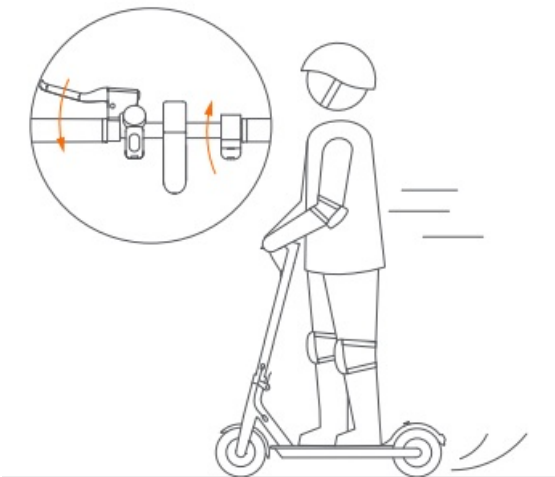

5. Tilt your body to the steering direction as you turn, and slowly turn the handlebar.

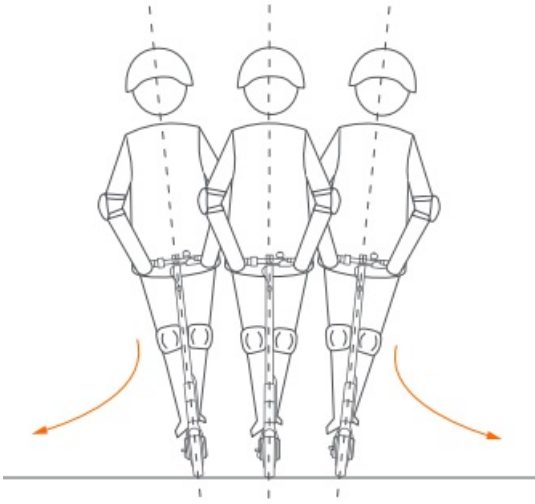

Safety Reminder Watch out for safety risks.



 Do not ride in the rain.



 Keep your speed between 5-10 km/h when you ride through speed bumps, elevator door stills, bumpy roads or other uneven surfaces. Slightly bend your knee to better adjust mentioned surfaces.

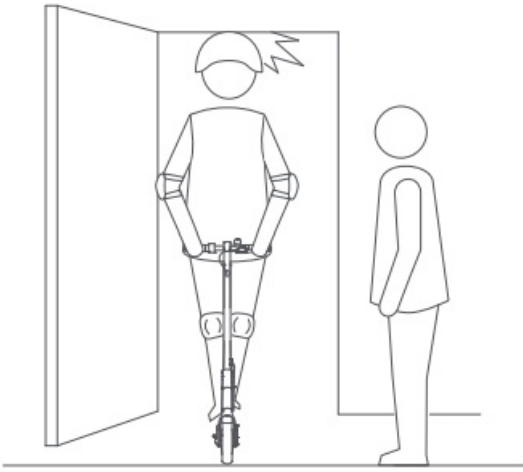

⚠️ Avoid hitting your head on door frames, elevators, and other overhead obstacles.



⚠️ Do not accelerate when going downhill, and brake in time to slow down. When encountering a steep incline, you need to step off the scooter and push, do not risk riding up.

⚠️ To prevent inappropriate use of the scooter, the rear wheel of the scooter must be locked with a padlock when parked.

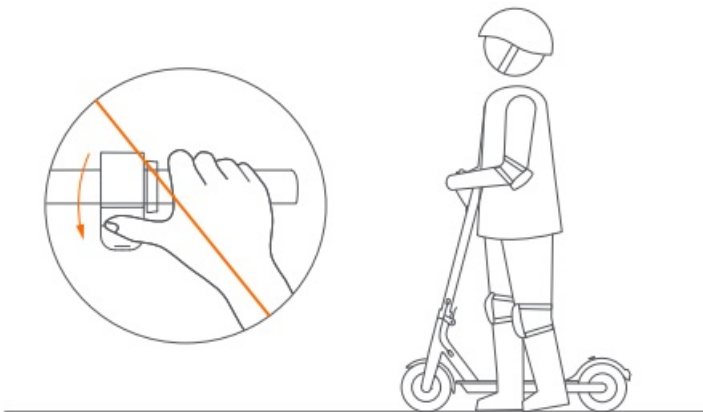

⚠️ Do not press the accelerator when you're walking alongside the scooter.

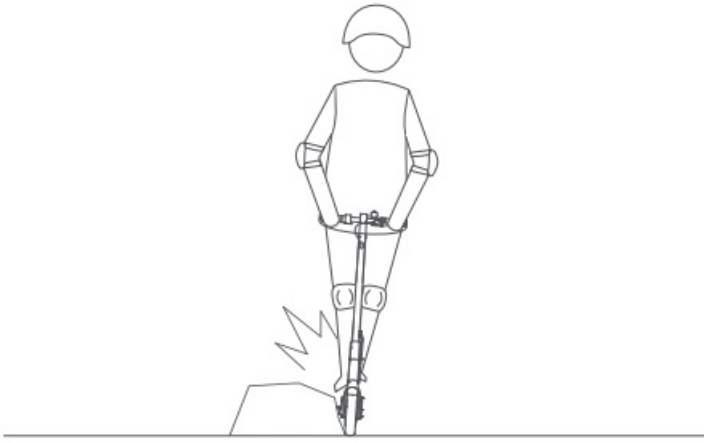

⚠ Always steer clear of obstacles.

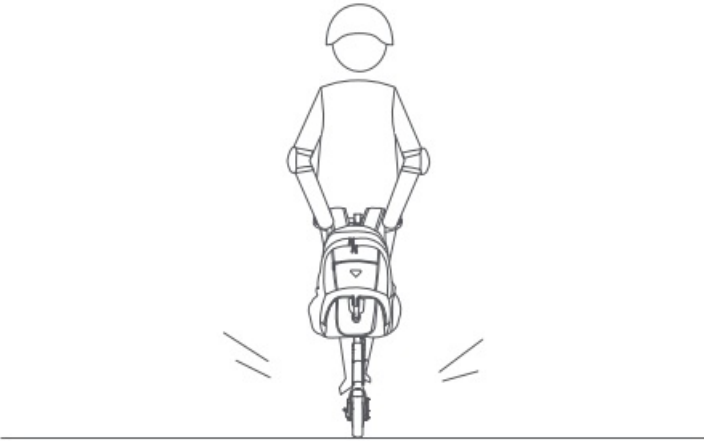

⚠ Do not hang bags or other heavy stuff on the handlebar.



⚠ Do not ride on one foot.

Do not try dangerous actions.

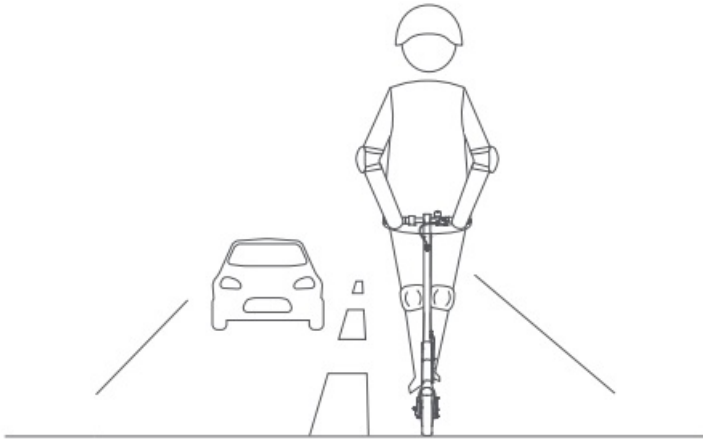

⊗ Do not ride in traffic lanes or residential areas where vehicles and pedestrians are both allowed.

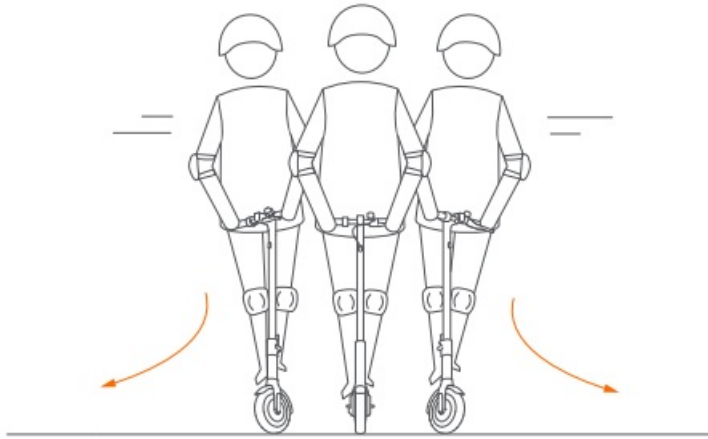

⊗ Do not abruptly change the steering direction at high speed.



⊗ Do not ride through puddles or any other (water) obstacles. In such a case please lower your speed and bypass the obstacle.

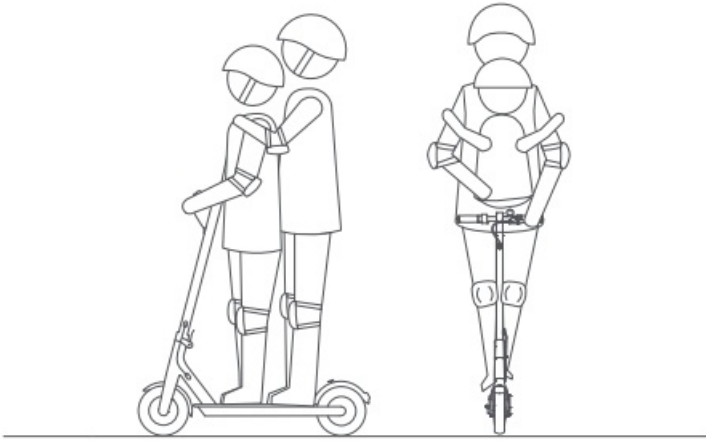

⊗ Do not ride with anyone else, including children.



⊗ Do not keep your feet on the rear mudguard.

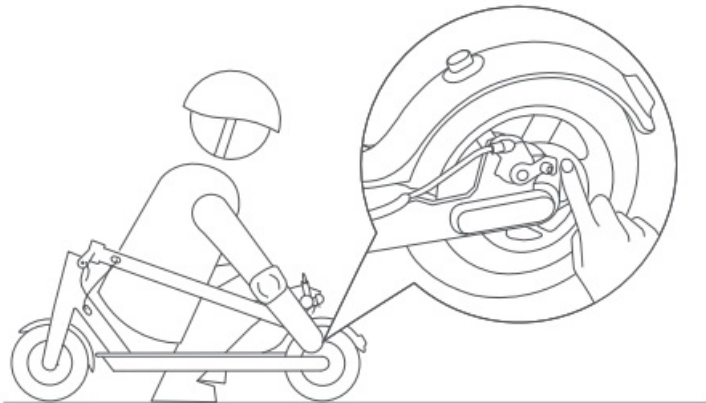

⊗ Do not touch the disc brake.



⊗ Do not let go of the handlebar while riding.

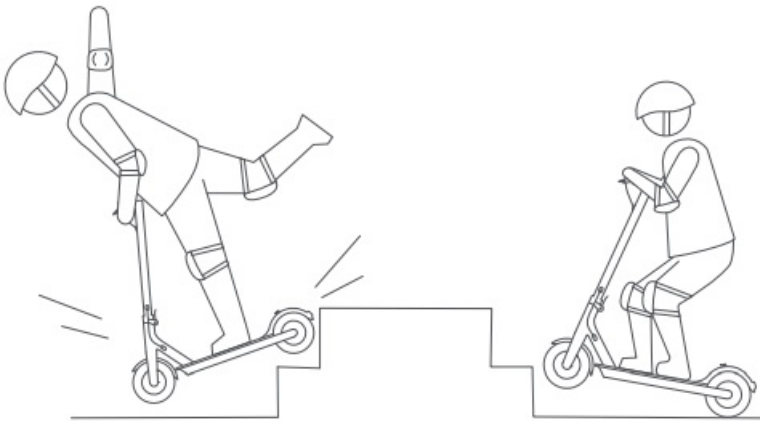

⊗ Do not try riding up or down stairs, nor try jumping over obstacles.

Safety Instructions

- The scooter is intended for riders older than 16 years. Do not ride the Scooter if you suffer from reduced physical, sensorial or mental capabilities. Riders with a lack of experience or knowledge should drive carefully. Children should not play with the Scooter or parts of it nor should cleaning or maintenance be done by children. The use of the machine results in the transmission of vibrations throughout the driver's body.
- This electric scooter is a leisure device. However, when entering a public area, it is considered a vehicle subject to possible risks. For your own safety, please follow the instructions in the manual as well as local traffic laws and regulations.
- At the same time, you should understand that risks cannot be entirely avoided as others may violate traffic regulations and drive incautiously, and you're exposed to road accidents just as when you're walking or biking. The higher the speed the longer the stopping distance. On a smooth surface, the scooter may slip, lose balance, and even result in a fall. Be cautious when riding, don't speed and keep a safe distance from other road users, especially when riding in unfamiliar areas.
- Respect pedestrians' Right of Way. Try not to startle them while driving, especially children. When you ride from behind pedestrians, ring your bell to give them a heads-up and slow your scooter down to pass from their left (applicable to countries where vehicles drive on the right). When you ride across pedestrians, keep to the right at a low speed. When you drive across pedestrians, keep the lowest speed or getting off the vehicle.
- Closely follow the safety instructions in the manual especially in China and countries that lack relevant laws and regulations regarding electric scooters. Xiaomi Communication Co., Ltd. shall not be liable for any financial losses, physical injuries, accidents, legal disputes and other interest conflicts resulted from actions that violate user instructions.
- Riding with high speed or a speed that is not appropriate or adequate for the situation (bad weather conditions, bad surface conditions, or the like) may lead into a potential loss of stability or loss of control. To reduce any risk, you must follow all instructions in this user manual. Be careful when mounting and dismantling the product, it may fall and cause injury.

- Do not lend your scooter to whoever does not know the operations. And when you do lend it to your friends, please take the responsibility to ensure he/she knows the operations and wears the safety gear.
- Check the scooter before every use. When you note loosen parts, low battery alerts, flat tires, excessive wear, strange sounds, malfunctions and other abnormal conditions, stop riding immediately and call for professional support.
- Always place the scooter on its stand on a flat and stable surface. The scooter must be placed with the stand against the slope to prevent it from tipping over. Never place the scooter with the front facing down the slope, as the stand may close and tip the machine. Once the scooter is on its stand, check its stability to avoid any risk of falling (by slip, wind or slight jolt). Do not park the scooter in a busy area, but rather along a wall. If possible, always choose to park your scooter on flat ground.
- Wear a helmet, elbow pads and knee pads in case of a fall to avoid injury. Poor driving can lead to falls or serious accidents. Store the electric scooter indoors when not in use. Read the instruction manual and drive the electric scooter carefully. You should only operate the electric scooter after you have understood and applied all the safety rules. The scooter operator will be responsible for any damage or injury caused by failure to follow the instructions in the owner's manual. For a better driving experience, it is recommended to conduct a regular maintenance of the product. Refer to the user manual for more information. Please read the user manual before charging the battery. DO NOT drive in rain or puddles. Required age of driver: 16 to 50 years. Not allowed for children.
- Do not touch the brake system, it could cause injuries.
- To avoid inappropriate use, it is necessary to start coasting the scooter to activate the motor and the accelerator. When the scooter is stopped, the accelerator does not work.

Folding and Carrying

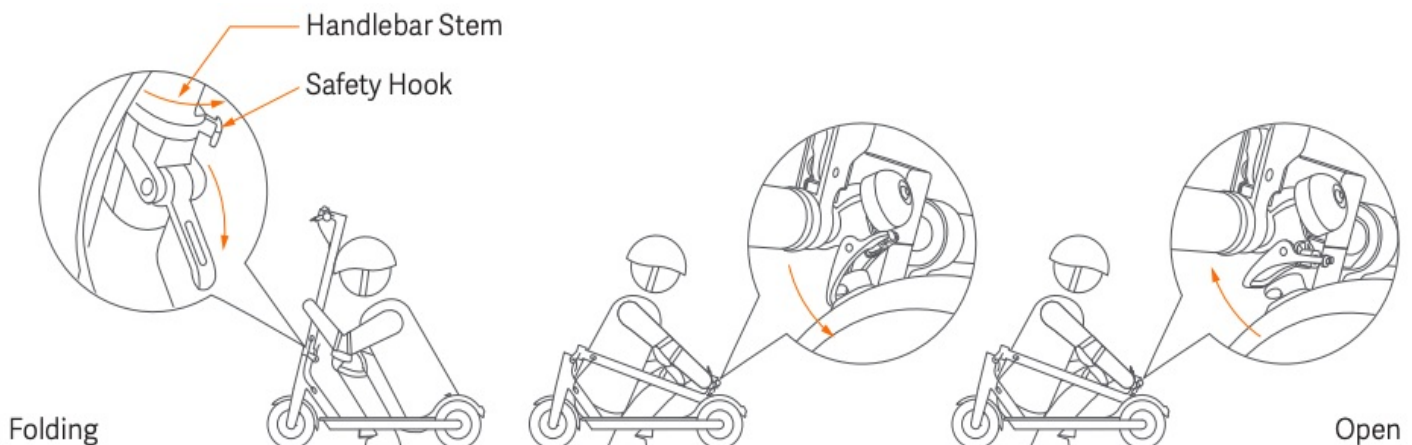

The scooter needs to be turned off before folding. Hold the handlebar stem, turn it counterclockwise to open the safety hook and open the quick release lever. Align the bell and the buckle and hook them. When opening, disengage the bell lever from the buckle on the mudguard. Fold the handlebar stem up, close the quick release lever and turn the handlebar stem clockwise to close the safety hook.

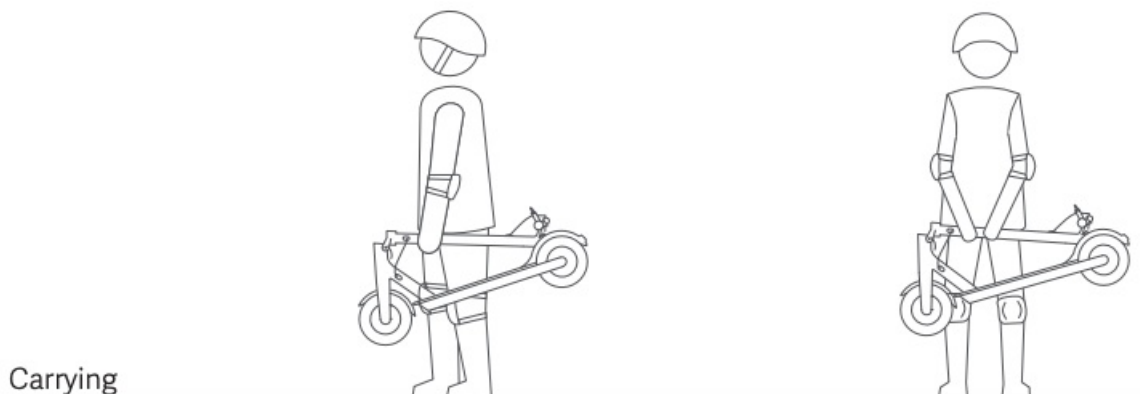

Hold the handlebar stem with either one hand or both hands.

Daily Care and Maintenance

Cleaning and Storage

If you see stains on the scooter's body, wipe them off with a damp cloth. If the stains won't scrub off, put on some toothpaste, and brush them with a toothbrush, then wipe them off with a damp cloth. If you see scratches on plastic parts, use sandpaper or other abrasive materials to polish them.

Notes: do not clean the scooter with alcohol, gasoline, kerosene or other corrosive and volatile chemical solvents to prevent dire damage. Do not wash the scooter with a high-pressure water spray. During cleaning, make sure that the scooter's turned off, the charging cable is unplugged, and the rubber flap is closed as water leakage may result in electric shock or other major problems.

When the scooter's not in use, keep it indoors where it is dry and cool. Do not put it outdoors for long time. Excessive sunlight, overheating and overcooling accelerate tire aging and compromise the scooter and the battery pack's lifespan.

Tire Maintenance

Regularly check the tire pressure (at least every 2-3 months), the recommended tire pressure is 50 psi. Riding with an incorrect tire pressure reduces tire life and safety.

Maintenance and removal of the battery

Do not remove the battery. Removing the battery is complicated and can alter the operation of the machine: You can contact an authorized repairer if the product is still guaranteed. If the product is not guaranteed you can contact any specialized repairer of your choice. You can ask for the list of the authorized repairers to the customer service available at www.mi.com. For any further question, you can contact the customer service available at www.mi.com.

Spare tires supplied with the product are to be mounted on the wheel by a professional repairer. Removing the wheels is complicated and incorrect assembly can lead to instability and malfunctions:

- Please contact an authorized repairer if the product is still under manufacturer guarantee. You can ask for the list of the authorized repairers to the customer service available at www.mi.com.
- If the product is no longer under guaranteed you can contact any specialized repairer of your choice.
- Should you have questions, you can contact Xiaomi's customer service available at www.mi.com.

Do not place the battery in an environment where the ambient temperature is higher than 50°C or lower than -20°C (e.g., do not leave the scooter or the battery pack in a car under direct sunlight for an extended time). Do not throw the battery pack into fire as it may lead to battery failure, battery overheating, and even another fire. If the scooter is expected to be left idle for more than 30 days, please fully charge the battery and place it in a dry and cool place. Keep in mind to recharge it every 60 days to protect the battery from potential damage which is beyond limited warranty.

Scooter shall be only be used with original batteries and charging of the Scooter shall only be done by the original charging adapter supplied with the Scooter (or any battery model or charging adapter model approved by the manufacturer as compatible).

Always charge before exhausting the battery to prolong the battery's lifespan. The battery pack performs better at normal temperature, and poor when it is below 0°C. For instance, when it is below -20°C, the riding range is only half or less at normal state. When the temperature rises, the riding range restores. For detailed information, please refer to Mi Home / Xiaomi Home App.

The external flexible cable of this transformer cannot be replaced; if the cord is damaged, the transformer must be discarded and replaced by a new one. Should you have questions, you can contact Xiaomi's customer service available at www.mi.com.

Note: fully charged Mi Electric Scooter Pro will last for 120-180 days. The built-in intelligent chip will keep a log of its charging and discharging records. The damage caused by prolonged no charge is irreversible and is beyond limited warranty. Once the damage is done, the battery cannot be recharged (non-professionals are forbidden to dismantle the battery pack, as it may cause electric shock, short circuit or even major safety accidents).

In case of accident or breakdown: Please contact an authorized repairer if the product is still under guarantee. If not, you can contact any specialized repairer of your choice. You can ask for the list of the authorized repairers to the

customer service available at www.mi.com. For any question, please contact Xiaomi's customer service available at www.mi.com.

Efforts have been made to simplify wording in the user manual for users. When an action appears too complicated for a user, he is advised to contact an authorized or a specialized repairer or Xiaomi's customer service.

Adjusting the disc brake

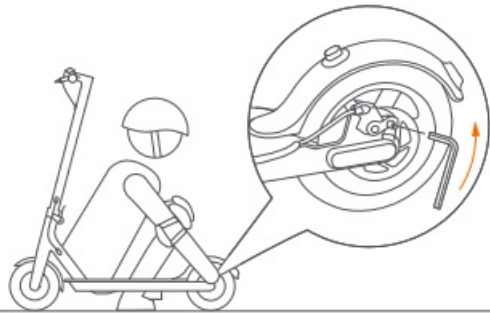

If the brake is too tight, use the 4 mm Allen key to loosen the screw on the caliper. Then slightly adjust the brake line (decrease the exposed length), and tighten the screw again.

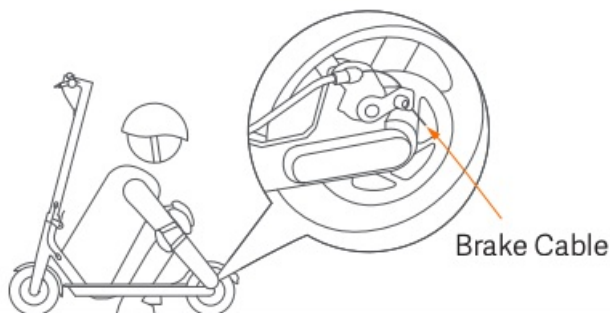

If the brake is too loose, loosen the screw on the caliper. Then slightly adjust the brake line (increase the exposed length), and tighten the screw again.

Tire Valve Stem

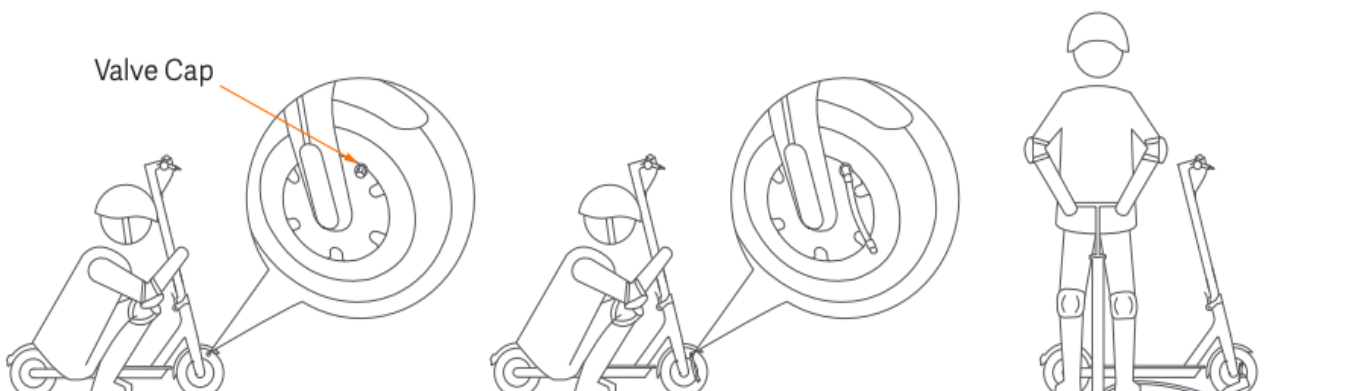

Unscrew the valve cap.

Connect the extension nozzle to the tire valve stem.

Connect the pump to inflate the tire.

Adjust the handlebar

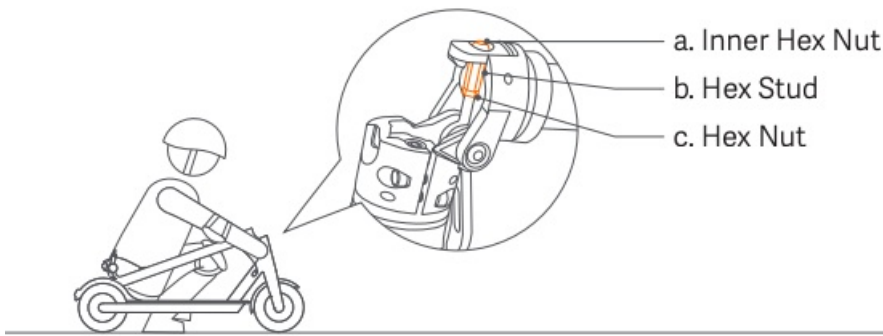

Long-term use of the scooter may result in loose screws, causing the handlebar stem to get unstable. If you notice the handlebar stem gets shaky when riding, follow the steps below.

Tools:

I: 8-10 mm wrench

II: 4 mm Allen key

Note: These tools are to be prepared by the user.

Steps:

1. When in the folded state (see page 12), use tool I to loosen "c" (clockwise).
 2. Use tool I to loosen "b" (clockwise).
 3. Use tool II to adjust "a" (clockwise) to the appropriate position, and use tool I to tighten "b" (counterclockwise).
 4. Fold the handlebar stem up, close the quick release lever and turn the handlebar stem clockwise to close the safety hook.
 5. Shake the handlebar stem to see if the problem has been resolved. If not, repeat step 2 and 3. If it has, continue to step 6.
 6. Return to the scooter to the folded state and use tool I to tighten "c" (counterclockwise).
- * Step 6 is mandatory.

Specifications

Product	Name	Mi Electric Scooter Pro
	Model	DDHBC02NEB
Dimensions	Vehicle: L × W × H (cm) ^[1]	113×43×118
	After Folding: L × W × H (cm)	113×43×49
Net Weight	Vehicle Net Weight (kg)	Approx. 14.2
Riding	Load Range (kg)	100
	Age	16–50
	Body Length (cm)	120–200
Assembled Electric Scooter	Max. Speed (km/h)	Approx. 25
	General Range (km) ^[2]	Approx. 45
	Max. Climbing Angle (%)	Approx. 20
	Suitable Surfaces	Cement, asphalt and dirt roads, with benches of less than 1 cm or crevices narrower than 3 cm.
	Operating Temperature (°C)	-10~+40
	Storage Temperature (°C)	-20~+45
	Ip Rating	IP54
	Charging Time (h)	Approx. 8
Battery Pack	Rated Voltage (VDC)	37 V =
	Max. Input Voltage (VDC)	42 V =
	Rated Capacity (Wh)	474
	Intelligent Battery Management System	Unusual temperature/short circuit/under voltage/overcurrent/dual overcharge/dual over-discharge protections
Wheel Motor	Rated Power (kW)	0.3
	Max. Power (kW)	0.6
Charging Adapter	Output Power (kW)	0.071
	Input Voltage (V)	100–240 ~
	Output Voltage (V)	42 V =
	Output Current (A)	1.7
Tire	Tires	Material: Natural rubber, synthetic rubber + cord Size: 8-1/2*2.0
	Tubes	Material: Butyl rubber Size: 8-1/2*2.0 A/V straight nozzle
Bluetooth	Frequency Band (s)	2.4000-2.4835GHz
	Max. RF Power (mW)	100

[1] Vehicle height: from the ground to the top of the scooter.

[2] General range: measured when there is no wind and at 25°C, the scooter's fully charged to ride at a constant speed of 15 km/h on a flat surface with a load of 75 kg.

Trademark and Legal Statement

 is the trademark of Xiaomi Inc. All rights reserved. Ninebot is a registered trademark of Ninebot (Tianjin) Technology Co., Ltd., all other trademarks and trade names are those of their respective owners.

This manual is produced and copyrighted by Ninebot (Beijing) Technology Co., Ltd. No entity nor individual may use, duplicate, modify, copy, spread any part of this manual, or bundle or sell with other products without the written consent of Ninebot (Beijing) Technology Co., Ltd.

All the described functions and instructions were up to date at the time of printing this manual. However, the actual product may vary due to improved functions and design.

Manufactured for: Xiaomi Communications Co., Ltd.

Manufactured by: Ninebot (Changzhou) Tech Co., Ltd. Address: 16F-17F, Block A, Building 3, No.18, Changwu Mid Rd, Wujin Dist., Changzhou, Jiangsu, China.

Certifications

European Union Compliance Statement

Battery recycling information for the European Union



Batteries or packaging for batteries are labeled in accordance with European Directive 2006/66/ EC and amendment 2013/56/EU concerning batteries and accumulators and waste batteries and accumulators. The Directive determines the framework for the return and recycling of used batteries and accumulators as applicable throughout the European Union. This label is applied to various batteries to indicate that the battery is not to be thrown away, but rather reclaimed upon end of life per this Directive.

In accordance with the European Directive 2006/66/EC and amendment 2013/56/EU, batteries and accumulators are labeled to indicate that they are to be collected separately and recycled at end of life. The label on the battery may also include a chemical symbol for the metal concerned in the battery (Pb for lead, Hg for mercury, and Cd for cadmium). Users of batteries and accumulators must not dispose of batteries and accumulators as unsorted municipal waste, but use the collection framework available to customers for the return, recycling, and treatment of batteries and accumulators. Customer participation is important to minimize any potential effects of batteries and accumulators on the environment and human health due to the potential presence of hazardous substances.

Before placing electrical and electronic equipment (EEE) in the waste collection stream or in waste collection facilities, the end user of equipment containing batteries and/or accumulators must remove those batteries and accumulators for separate collection.

Waste Electrical and Electronic Equipment (WEEE) Directive



“All products bearing this symbol are waste electrical and electronic equipment (WEEE as in directive 2012/19/EU) which should not be mixed with unsorted household waste. Instead, you should protect human health and the environment by handing over your waste equipment to a designated collection point for the recycling of waste electrical and electronic equipment, appointed by the government or local authorities. Correct disposal and recycling will help prevent potential negative consequences to the environment and human health. Please contact the installer or local authorities for more information about the location as well as terms and conditions of such collection points”.

Restriction of Hazardous Substances Directive (RoHS)

This Ninebot (Changzhou) Tech Co., Ltd. product, with included parts (cables, cords, and so on) meets the requirements of Directive 2011/65/EU on the restriction of the use of certain hazardous substances in electrical and electronic equipment (“RoHS recast” or “RoHS 2”).

Radio and Telecommunications Terminal Equipment Directive



Segway Europe B.V.

EU Contact Address for regulatory topics only: Hogehilweg 8, 1101CC, Amsterdam, The Netherlands

This device meets the EU requirements on the limitation of exposure of the general public to electromagnetic fields

by way of health protection.

Hereby, [Ninebot (Changzhou) Tech Co., Ltd.] declares that the radio equipment type [DDHBC02NEB] is in compliance with Directive 2014/53/EU. The full text of the EU declaration of conformity is available at the following internet address: <http://www.mi.com/global/service/support/declaration.html>.

Importer:

Beryko s.r.o.

Na Roudné 1162/76, 301 00 Pízen

www.beryko.cz

File Downloads



Mi Electric Scooter Pro
User Manual

User Manual [Download](#) [optimized]

Electric Scooter Pro [Download](#)



Mi Electric Scooter Pro User Manual

User Manual [Download](#) [optimized]

Electric Scooter Pro [Download](#)

References

-  [Mi Global Home](#)
-  [Xiaomi United States - Xiaomi United States](#)
-  [Beryko.cz](#)
-  [Xiaomi United States - Xiaomi United States](#)
-  [Xiaomi Global Official Website Mi.com - Mi Global Home](#)

Related Manuals

1. [Mi Electric Scooter Pro 2 User Guide](#) Mi Electric Scooter Pro 2 Mercedes-AMG Petronas F1 Team Edition...
2. [Mi Electric Scooter Pro Manual](#) Mi Electric Scooter Pro Manual – Download [optimized]Mi Electric Scooter...
3. [Mi Electric Scooter User Manual](#) Mi Electric Scooter User Manual Thank you for purchasing Mi...
4. [Mi Electric Scooter Essential User Manual](#) Mi Electric Scooter Essential User Manual Package Contents User Manual...
5. [Mi Electric Scooter Manual](#) Mi Electric Scooter Manual – Download [optimized]Mi Electric Scooter Manual...
6. [Mi Electric Shaver User Manual](#) Mi Electric Shaver S500 User Manual We, SOOCAS (Shenzhen) Technology...