



TYGER ARMOR

BEFORE INSTALLATION

READ INSTRUCTIONS CAREFULLY BEFORE STARTING INSTALLATION. REMOVE CONTENTS FROM BOX AND VERIFY ALL PARTS ARE PRESENT. ASSISTANCE IS RECOMMENDED. FAILURE TO IDENTIFY DAMAGE BEFORE INSTALLATION COULD LEAD TO A REJECTION OF ANY CLAIM. IF ANY DAMAGE FOUND, PLEASE TAKE A PICTURE FOR THE CLAIM PURPOSE. PLEASE ALSO SEND THE PICTURES, ORDER NUMBER, AND DETAILS OF THE ISSUE TO SUPPORT@TYGERAUTO.COM.

Torque Value

Fastener Size	Class 8.8 Tightening Torque (ft-lbs)	Class 10.9 Tightening Torque (ft-lbs)
6mm	6-7	6-7
8mm	15-16	22-23
10mm	31-32	44-45
12mm	54-55	78-79
14mm	87-88	125-126

TG-AM2F20548

Parts List

- x1** Driver/Left Side Armor
- x1** Passenger/Right Side Armor
- x18** 8mm Plastic Washers
- x18** 8mm x 24mm x 2mm Flat Washers
- x18** 8mm Nylon Lock Nuts

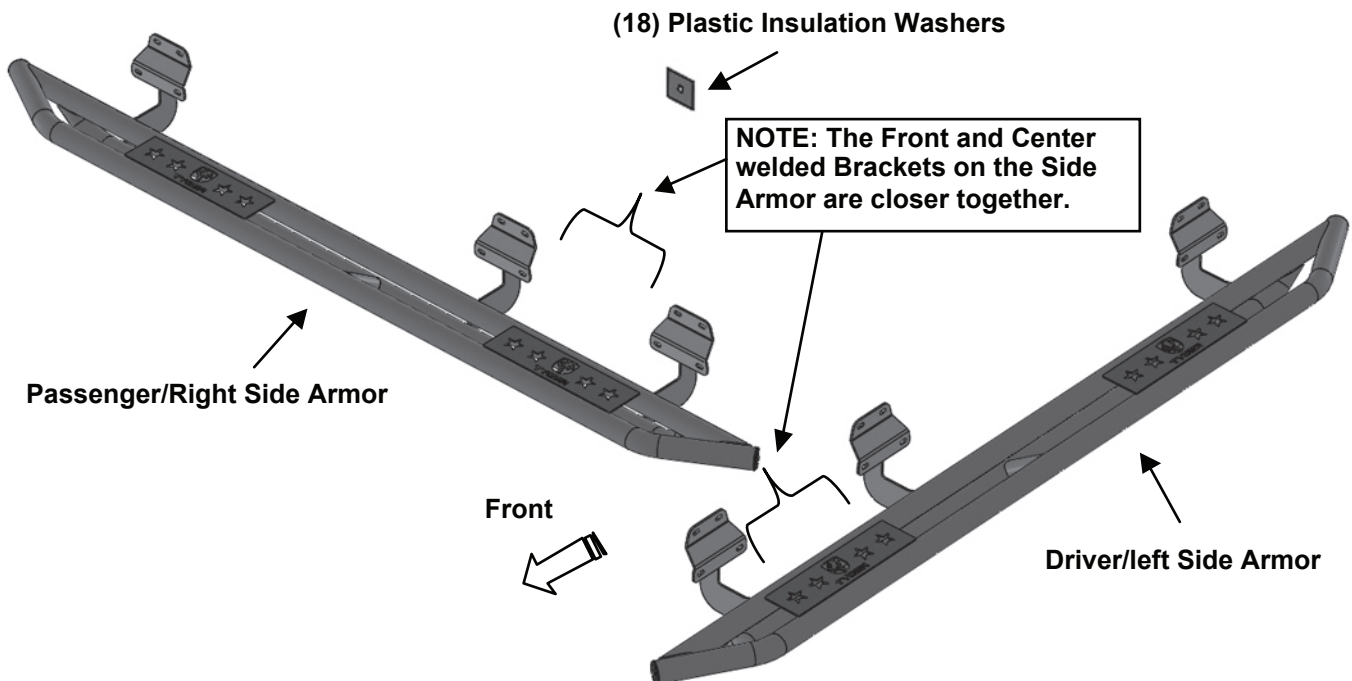



STEP 1

Start the installation under the passenger side of the vehicle. Locate the front factory running board mounting location along the inner side of the body, (Fig 1).

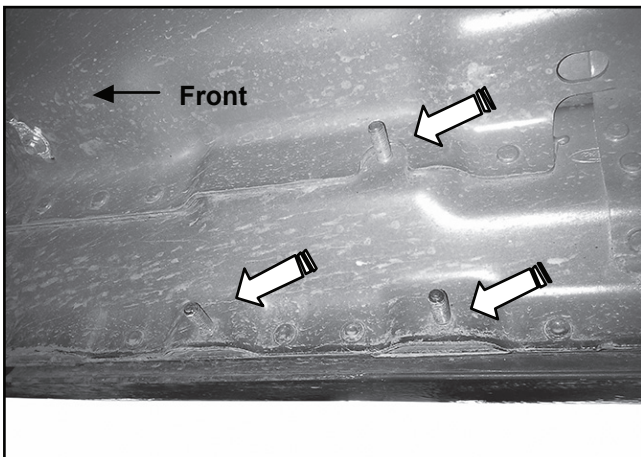

(Fig 1) Passenger side front mounting location

STEP 2

Slide (1) Plastic Washer over each of the (3) factory mounting studs in the body panel, (Figs 2-4).

IMPORTANT: The Plastic Washers are designed to prevent corrosion between the aluminum body panel and the steel mounting brackets. Do not install the Brackets without the Plastic Washers.

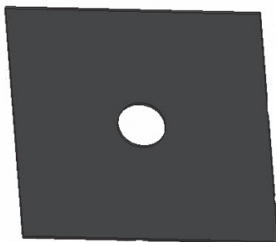

(Fig 2) Plastic Insulation Washer

STEP 3

Move along to the center mounting location and repeat Step 2 to install (3) Plastic Retainers onto the (3) factory mounting studs.

STEP 4

Continue to the rear end of the body panel and repeat Step 2 to install the remaining (3) Plastic Retainers onto the last (3) factory mounting studs.

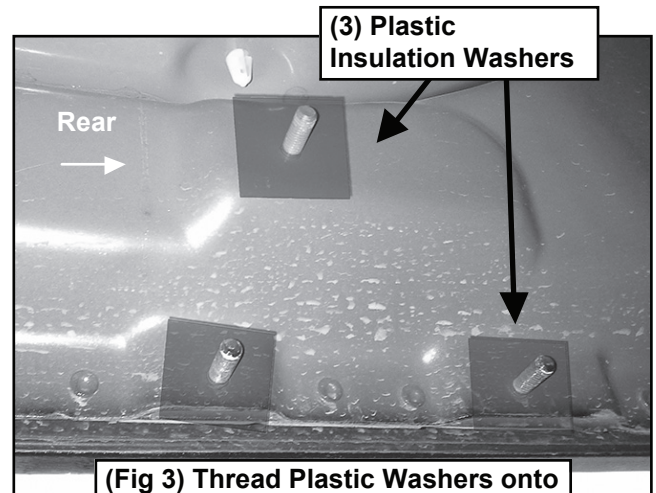

(Fig 3) Thread Plastic Washers onto all mounting studs. Passenger side rear mounting location pictured

(3) 8mm Flat Washers
(3) 8mm Nylon Lock Nuts

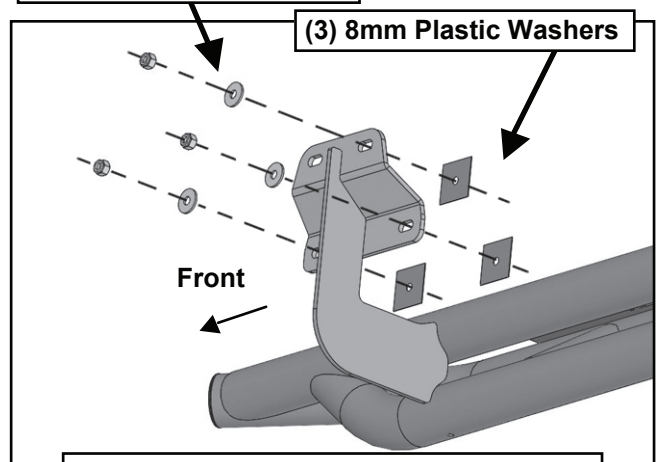

(Fig 4) Passenger/right front installation



STEP 5

Select the Passenger/right Side Armor.

NOTE: Use the illustration above to help identify the passenger Side Armor. The Front and Center Brackets on the Side Armor are closer together.

STEP 6

With assistance, hold the Passenger/right Side Armor up to the vehicle and over the mounting studs and Plastic Washers. Attach the Side Armor to the studs with (9) 8mm Flat Washers and (9) 8mm Nylon Lock Nuts, (Figs 4-6). Do not tighten hardware at this time.

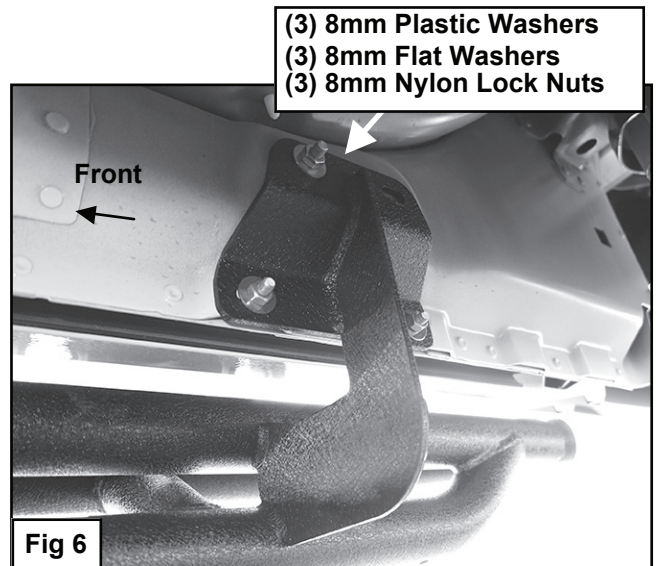
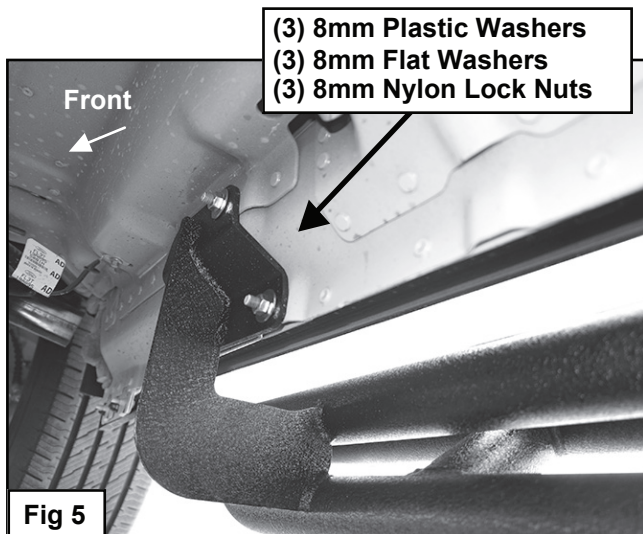

STEP 7

Level and adjust the Passenger/right Side Armor as desired and tighten all hardware.

STEP 8

Repeat Steps 1-7 to install the driver/left Side Armor assembly.

STEP 9

Do periodic inspections to the installation to make sure that all hardware is secure and tight.