

# SandPRO™ POOL FILTER SYSTEM OWNER'S MANUAL

ENGLISH

MODELS 35D (item 4706), 50D (item 4710), 75D (item 4711) and 550D (item 4728)

## IMPORTANT SAFETY RULES

Read all instructions BEFORE assembling and using  
this product. KEEP THIS MANUAL.



MODEL 35D (item 4706)



MODEL 50D (item 4710)



MODEL 75D (item 4711)

*Sand not included. USE ONLY #20 Silica Sand with a particle size of 0.45 mm – 0.55 mm*

## IMPORTANT DO NOT RETURN PRODUCT TO STORE

For technical assistance and missing parts, call Customer Service toll-free

**1.888.339.2546**

(press 135 at any time)

Monday through Thursday, 8:00 am to 5:00 pm MST

Friday, 8:00 am to 2:00 pm MST

Please visit our website, [www.game-group.com](http://www.game-group.com), for potential updates to these instructions.

---

**YOUR POOL FILTER SYSTEM HAS BEEN ENGINEERED AND MANUFACTURED TO OUR HIGHEST STANDARD FOR DEPENDABILITY, EASE OF OPERATION AND SAFETY. WITH PROPER CARE, IT WILL GIVE YOU YEARS OF DURABLE, TROUBLE-FREE PERFORMANCE. THANK YOU FOR YOUR PURCHASE.**

---

---

**READ ALL INSTRUCTIONS BEFORE ASSEMBLING AND USING THIS PRODUCT. FAILURE TO FOLLOW INSTRUCTIONS CAN CAUSE SEVERE AND/OR FATAL INJURY.**

---

**IMPORTANT  
DO NOT RETURN PRODUCT TO STORE**

For technical assistance and missing parts, call Customer Service toll-free

**1.888.339.2546**

(press 135 at any time)

Monday through Thursday, 8:00 am to 5:00 pm MST

Friday, 8:00 am to 2:00 pm MST

---

Please visit our website, [www.game-group.com](http://www.game-group.com), for potential updates to these instructions.

---

## TABLE OF CONTENTS

1. Safety Warnings . . . . .	4
2. General Information . . . . .	4
3. Technical Specifications . . . . .	5
4. Parts List/Reference . . . . .	6
5. Getting Started . . . . .	7
6. Assembly Instructions . . . . .	8
7. Connecting the Filter System. . . . .	10
8. Valve Operations . . . . .	12
9. Filter Operations. . . . .	13
10. Maintenance . . . . .	14
11. Troubleshooting. . . . .	15
12. Limited Warranty Statement . . . . .	17
13. Appendix: Exploded Parts Diagram . . . . .	18

---

## IMPORTANT

---

Clean, safe swimming pool water is a combination of two factors; filtration and water chemistry balance. One without the other will not give clean water.

The sand filter removes suspended particles but does not sanitize your pool. Pool chemistry is a specialized area and you should consult your local pool supply retailer or service specialist for details.

Operate your filtration system each day to achieve at least one complete turnover of your pool water.

Maintain a free chlorine level of 1 to 3 ppm and a pH range of 7.2 to 7.6 to keep your pool properly sanitized. Insufficient chlorine or an out of balance pH level will permit algae and bacteria to grow and make it difficult for your filter to clean the pool water.

---

## 1. SAFETY WARNINGS

---

**READ ALL WARNINGS BELOW. FAILURE TO DO SO COULD RESULT IN SERIOUS PERSONAL INJURY OR DEATH.**

---

- RISK OF SUCTION ENTRAPMENT HAZARD, WHICH, IF NOT AVOIDED CAN RESULT IN SERIOUS INJURY OR DEATH.
- Do not block pump suction at the pump or in the pool as this can cause severe injury or death.
- Electrical wiring MUST be installed by a trained professional and adhere to local code and regulations.
- Avoid electric shock. DO NOT USE power extension cords.
- Connect ONLY to a Ground-Fault Circuit Interrupter (GFCI) power outlet. Consult a qualified, professional electrician for safe and proper installation of the required electrical outlet.
- Incorrectly installed equipment may fail, causing severe injuries or damage to the pump-filter system.
- Never place or submerge the filter and/or pump in water.
- Trapped air in the pump-filter system may cause the tank cover to be blown off which can result in death, serious injury, or damage to the pump-filter system. Ensure all air is out of system before operating.
- NEVER use the valve lever as a handle to carry or lift the filter.
- NEVER change the position of the 4 way valve while the system is operating. ALWAYS unplug the system first.
- Install this product per your local electrical code and at least 10 feet (3.05m) away from the pool to prevent children from using the system to access the pool.
- Never PLUG or UNPLUG this unit from an electrical source while standing in water or with wet hands.
- NEVER service this unit with the electrical power cord connected.
- Do not use any petroleum based lubricant. Petroleum based products will destroy plastic parts.
- Do NOT operate the system while the pool is in use.
- KEEP CHILDREN AWAY from all electrical equipment.
- NEVER ALLOW CHILDREN TO OPERATE THIS EQUIPMENT.

---

**THESE SAFETY WARNINGS ARE NOT INTENDED TO INCORPORATE ALL POSSIBLE INSTANCES FOR RISK AND/OR SEVERE INJURY.**

---

## 2. GENERAL INFORMATION

---

This manual provides information relating to the installation, utilization and maintenance of the Pool Filter System. The pump included with the filtration system is a horizontal, self-priming centrifugal pump. For the pump to function correctly, the water temperature must not exceed 104°F/40°C. The filter included in the filtration system is equipped with a container drainage system, pressure gauge and built-in container components. The filter container comes ready to plug-in and is supplied with a user-friendly 4 way valve, an approved filter pump with hair and lint basket and a plastic base for ready on-site mounting.

### How Sand Filtration Works

The Pool Filter System is designed to use special silica sand to remove dirt particles from pool water. Filter sand is loaded into the filter tank and functions as a permanent dirt and debris removing medium. Pool water, which contains dirt particles, is pumped through the intake hose leading from the pool to the filter tank and is directed by the filter control valve to the top of the filter tank. As water is pumped through the filter sand, dirt particles are trapped by the bed of sand and filtered out. The cleaned/filtered water is then returned from the bottom of the filter tank, through the control valve and back to the pool through the return hose. This sequence is continuous and automatic and provides total recirculation of pool water through your filter and hose connections.

After a period of time, the accumulated dirt in the filter causes a resistance to the flow of water and an increase in pump pressure (psi). When this happens, it is time to clean (backwash) the filter. To backwash the system, you must change the valve to the backwash position. When in backwash mode, the water flow is automatically reversed through the filter so that it is directed to the bottom of the tank, up through the sand, which flushes any trapped dirt and debris out through the waste line. Once the filter is backwashed and cleaned of dirt, the control valve should be moved into the rinse position to allow the sand to settle. After rinsing, the filter valve should be changed back to the filtration position to resume normal filtering.

## Powering the Filter Pump

It should be noted that the Pool Filter System does not have an on/off switch. Rather, power to the filter pump is connected and disconnected by means of plugging in and unplugging the power cord from the power source. It is important that you read and follow the instructions on proper power supply sources (see Section 5, Power Source Requirements) to avoid overloading the pump motor and/or electric shock.

## Sand & Initial Preparation

The Pool Filter System requires a specific type of sand (not included) for optimum operation: namely, silica sand with a particle size of 0.45 mm - 0.55 mm. You can purchase this sand at most pool supply stores. While the sand will come packaged, it is important that the sand be cleaned prior to running the filter system in filtration mode (see Section 9, Filter Operations).

## Installation

Read and understand this manual carefully before installation. Failure to follow all instructions may result in electric shock, serious personal injury or death.

### 3. TECHNICAL SPECIFICATIONS

---

<b>SandPRO 35D (item 4706, 1/3 hp)</b>		<b>NOTE: Requires 25 lbs (11.3 kg) not included</b>
<b>Item</b>	<b>U.S. Units</b>	<b>Metric Units</b>
Pump Flow Rate	2220 GPH	8.4 m3/hr
Design Flow Rate	660GPH	2.5 m3/hr
MAX Operating Pressure	40 psi	2.75 Bar
Filtration Area	0.53 ft2	0.05 m2
Rated Voltage	110 V	110 V
Sand Volume	25 lbs	11.3 kg

---

---

<b>SandPRO 550D (item 4728, 1/2 hp)</b>		<b>NOTE: Requires 25 lbs (11.3 kg) not included</b>
<b>Item</b>	<b>U.S. Units</b>	<b>Metric Units</b>
Pump Flow Rate	2,400 GPH	9.1 m3/hr
Design Flow Rate	912 GPH	3.5 m3/hr
MAX Operating Pressure	40 psi	2.75 Bar
Filtration Area	0.76 ft2	0.07m2
Rated Voltage	110 V	110 V
Sand Volume	25 lbs	11.3 kg

---

---

<b>SandPRO 50D (item 4710, 1/2 hp)</b>		<b>NOTE: Requires 50 lbs (22.6 kg) not included</b>
<b>Item</b>	<b>U.S. Units</b>	<b>Metric Units</b>
Pump Flow Rate	2,400 GPH	9.1 m3/hr
Design Flow Rate	912 GPH	3.5 m3/hr
MAX Operating Pressure	40 psi	2.75 Bar
Filtration Area	0.76 ft2	0.07m2
Rated Voltage	110 V	110 V
Sand Volume	50 lbs	22.6 kg

---











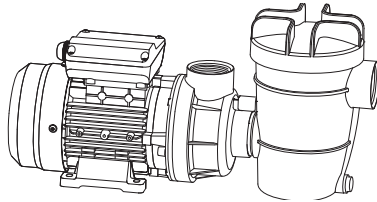
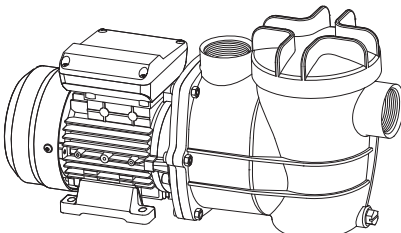

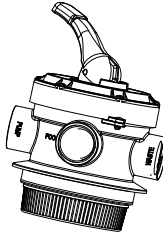
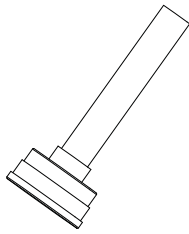
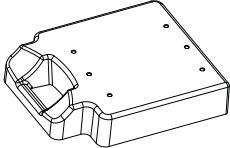
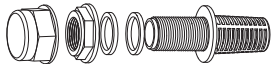
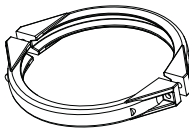
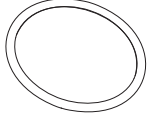

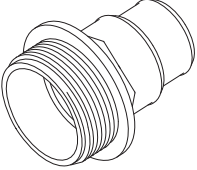
---

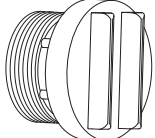
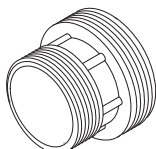
<b>SandPRO 75D (item 4711, 3/4 hp)</b>		<b>NOTE: Requires 75 lbs (34 kg) not included</b>
<b>Item</b>	<b>U.S. Units</b>	<b>Metric Units</b>
Pump Flow Rate	3,120 GPH	11.8 m3/hr
Design Flow Rate	1,392 GPH	5.3 m3/hr
MAX Operating Pressure	40 psi	2.75 Bar
Filtration Area	1.16 ft2	0.11 m2
Rated Voltage	110 V	110 V
Sand Volume	75 lbs	34 kg

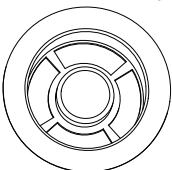
---

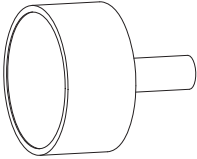
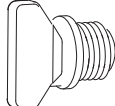
#### 4. PARTS LIST/REFERENCE (some parts may be pre-assembled)

Before starting installation, check to make sure all parts are present in package. Parts listed as description (quantity)

Pump, Strainer Housing, Basket & Lid (1) <i>(only model 35D, item 4706, shown assembled)</i>	Pump, Strainer Basket & Lid (1) <i>(shown assembled)</i>	Filter tank (1)
		
4 Way Valve (1)	Manifold (1)	Base Plate (1)
		
Filter Drain Plug Assembly (1)	Flange Clamp (1)	Tank Large O-Ring (1)
		
Hose Clamp & Tip (2)	Hose Adapter (5)	Hose Adapter O-Ring (3)
		
Waste (Backwash) Plug (1)	Short Intex adapter (2)	Short Intex Adapter Gasket (2)
		
Sand Shield (1)	1 1/4" (32mm) Hose (1)	Pressure Gauge (1)
		
Pressure Gauge Plug (1)	Pump Mount Screw & Washer (4)	Flange Screw & Nut (2)
		
		Pump Drain Plug & Gasket (1)
		

Owner's Manual

**Note:** Some parts may be pre-installed at the factory. Parts not shown to scale.

## 5. GETTING STARTED

---

### Unpacking Your Filter System

This product requires assembly.

Carefully remove the product and all parts. Make sure all items listed in the Parts List/Reference are included. Please note that some parts may be pre-assembled.

Inspect everything carefully to make sure nothing is damaged.

Do not discard packing material until you have satisfactorily operated the product.

If any parts are missing or damaged, please call the number listed on the front page of this manual.

NOTE: Some parts may be located within the filter tank. To access these parts you must remove the tank cover.

### Tools & Equipment Required

The following items are not included with your new filter system, but will be required for proper installation and operation:

- ¼" Blade screwdriver
- #2 Phillips screwdriver
- Silicone based lubricant
- Ground-Fault Circuit Interrupter (GFCI) power outlet – Must be installed by a certified electrician
- One 1½" (38mm) backwash hose

---

### **IMPORTANT: REQUIRES #20 SILICA SAND (NOT INCLUDED) SEE TABLE ON PAGE 5**

---

The above equipment list is based on the assumption that your above-ground pool is assembled, filled with water and that your pool is equipped with the necessary filtration hoses needed to operate with a filter (cartridge or otherwise). If your pool is not assembled, please refer to the pool's installation manual for details. If you do not have hoses for your pool's intake and return, you will need to purchase the hoses from a pool supply store.

This Pool Filter System is designed to connect to pools with standard 1¼" or 1½" (32mm or 38mm) diameter hose connectors and has 2¼" (57mm) hose adapters for INTEX® pools. If your pool has a hose connector with a different size and/or type, you may need to purchase an adapter at your local pool supply store or hardware retailer.

### Know Your Pool

Before you begin installation, it is a good idea to know certain specifications of your pool:

- How big is your pool?
- How many liters/gallons does it hold?
- What size hose does it use? (i.e. 1¼" dia, 1½" dia or 2¼" dia (32mm, 38mm or 57mm))
- What kind of hose connection does it use? ( i.e. threaded/unthreaded)

### Filter Location

The Pool Filter System needs to be located on a 2 x 3 ft (0.6 x 0.9 m) completely level, hard surface lower than the pool's water level and away from the pool to prevent access to children. The hard surface may be made of concrete, gravel, patio pavers, etc.

### Power Source Requirements

This system is equipped with a standard electrical cord and plug which should only be connected to a power outlet that has been installed by a professional electrician and adheres to local codes and regulations. To AVOID electric shock, serious personal injury or death, power cord extensions should NOT BE USED. DO NOT handle power cords or equipment with wet hands, while standing in water or while wet.

## 6. ASSEMBLY INSTRUCTIONS (some parts may be pre-assembled)

Follow the steps below and the corresponding diagrams for assembly.

- NOTE: This step is for model 35D only.** Be sure o-ring is in place and seated properly on the strainer housing threads. Thread the strainer basket housing (5 full turns maximum) into the pump motor. Do not overtighten. Secure with the clip.
- Place the strainer basket into the strainer housing. Be sure that the opening in the basket is aligned with the opening in the housing. Secure lid.

**Note: The filter system should be in its permanent location before filling the tank with sand. Otherwise the unit may difficult to move.**

- Secure the pump to the filter base with the mounting screws. The side of the pump **WITHOUT** the metal ID plate should face towards the groove.
- Installing the drain valve.
  - Place a gasket onto the threaded body of the drain valve. Place the valve through the drain hole in the bottom of the tank (from the inside, threaded section to the outside).
  - Place a gasket on the outside of the drain valve, pressing it to the tank and screw on the threaded collar.
  - Ensure all of the components are tight, then screw the drain cap onto the valve.
- Place the filter tank into the notch located in the base plate.
- Place the manifold assembly into the tank.
- Filling the filter tank with sand.

**CAUTION: AVOID BREATHING IN DUST. USE A BREATHING MASK APPROVED FOR DUST & SAND AND EYE PROTECTION WHILE FILLING THE TANK.**

- Fill the tank 1/3 full with water.
- Place the sand shield on the center stem of the manifold. This will ensure that when filling the tank, no sand will enter the manifold assembly.
- Carefully fill the filter tank with the correct amount of #20 silica sand noted below.
  - SandPRO 35D (item 4706, 1/3 hp) requires 25 lbs (11.3 kg)
  - SandPRO 550D (item 4728, 1/2 hp) requires 25 lbs (11.3 kg)
  - SandPRO 50D (item 4710, 1/2 hp) requires 50 lbs (22.6 kg)
  - SandPRO 75D (item 4711, 3/4 hp) requires 75 lbs (34 kg)Do not exceed the recommended quantity/weight of sand.

**IMPORTANT: Remove the sand shield after adding sand. Keep for future use.**

- Securing the 4 way valve to the tank.

**IMPORTANT: Be sure center pipe of the manifold is nested in the 4 way valve.**

- Install the tank o-ring onto the bottom of the 4 way valve.

**NOTE: Apply a silicone grease or pool lube around the seal before installing it onto the valve. This will allow for an easier installation and provide a better seal.**

- Place the valve onto the tank. Install flange clamp around tank and valve flange. Tighten just enough so that the valve may be rotated on tank for final positioning. Align the valve so the PUMP port is facing the pump motor OUTLET.
- Connecting the pump to the valve.
    - Attach adapters to the OUTLET on the pump and the PUMP port on the valve.
    - Connect the ports with the filter hose. Secure with the hose clamps. Place tips over the ends of the hose clamps.
    - Tighten screws on the clamp until there is less than a 1/4" (6.3mm) gap between the 2 halves.
  - Remove the pressure gauge plug and attach the pressure gauge. Do not overtighten. Keep the plug for future use.
  - Screw the plug into the WASTE (backwash) port. Remove when backwashing.

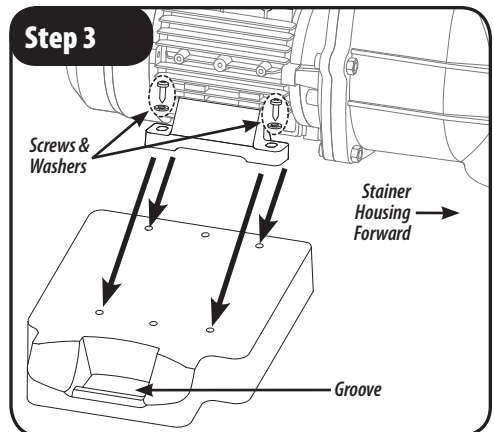
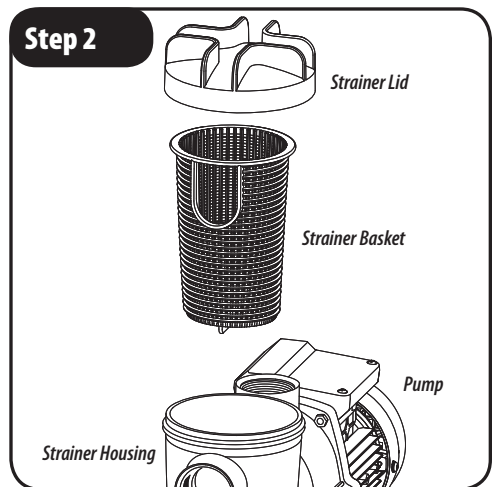
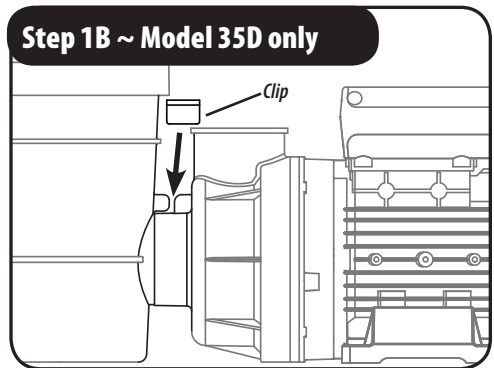
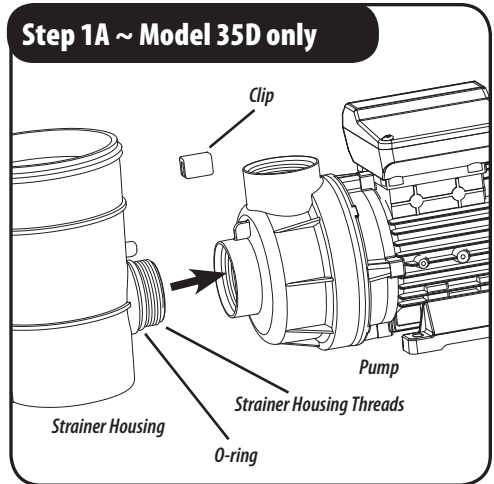

### Step 4

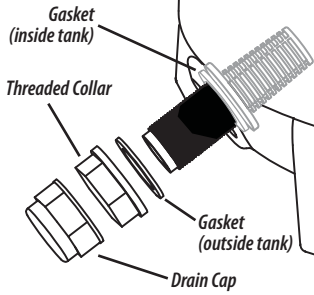

### Step 7

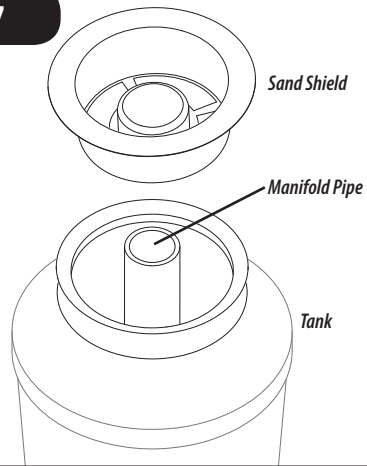

### Step 8

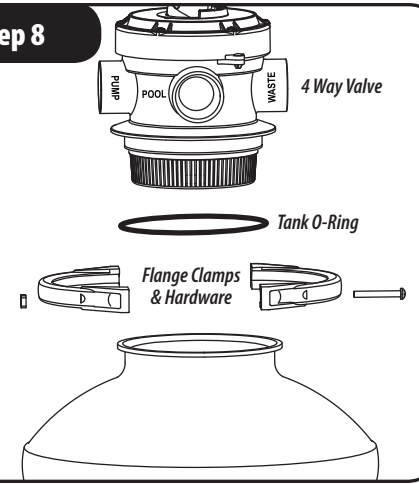

### Step 5

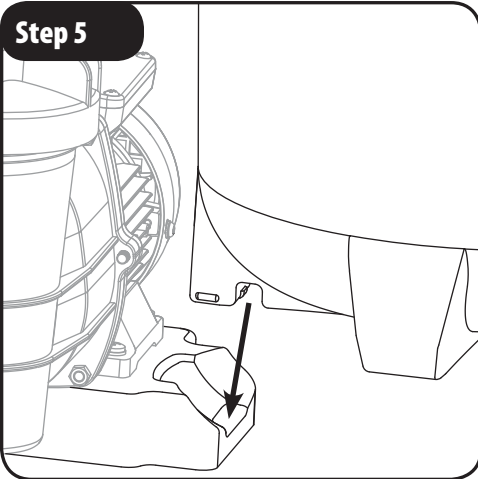

### Step 6

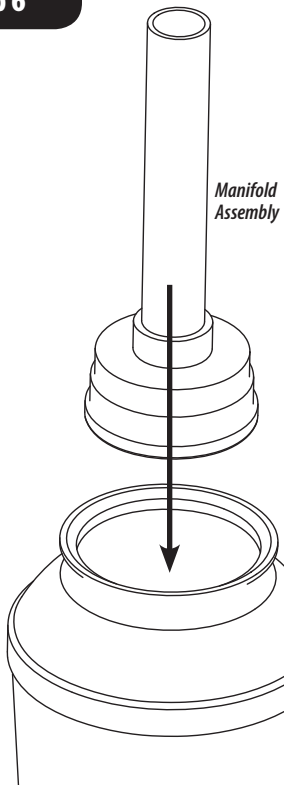

### Step 9

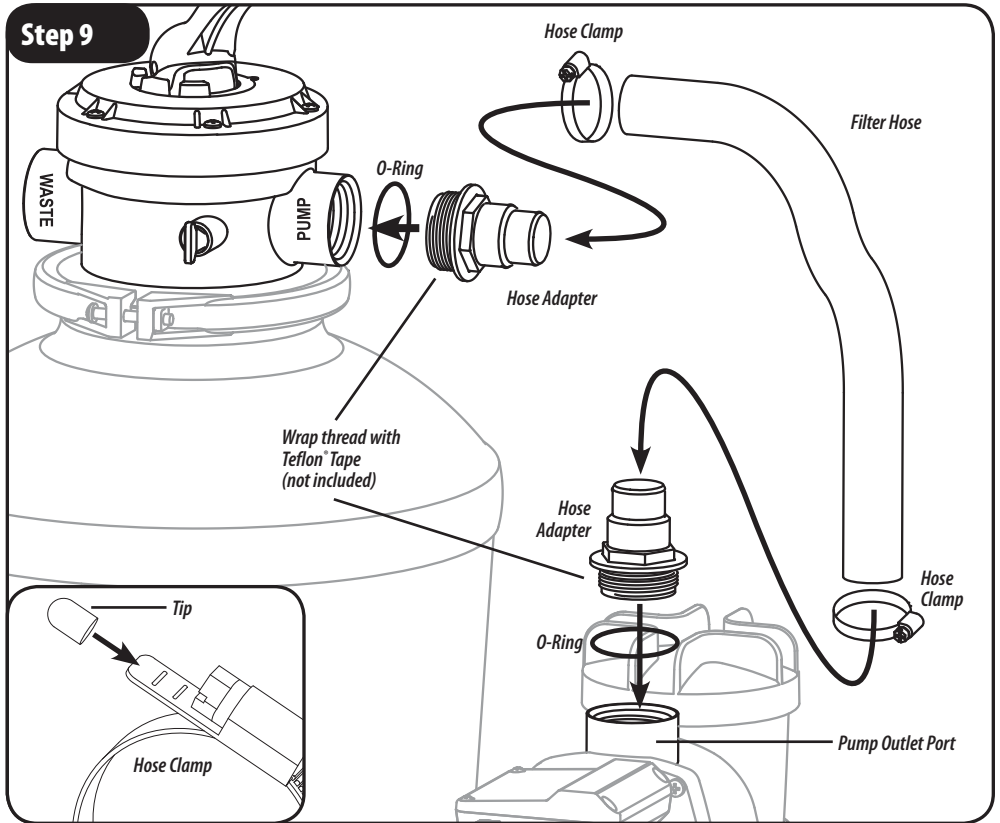

### Step 10

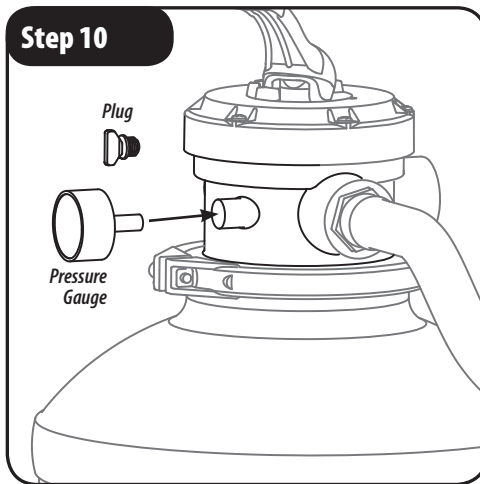

### Step 11

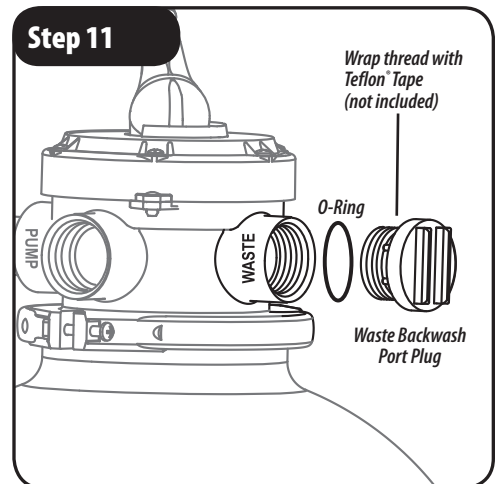

## 7. CONNECTING THE FILTER SYSTEM

---

**STOP: BEFORE YOU BEGIN TO CONNECT HOSES TO THE FILTER AND PUMP, MAKE CERTAIN THAT NO WATER CAN FLOW THROUGH THE INTAKE OR RETURN HOSES CONNECTED TO THE POOL. SOME POOLS HAVE SHUT OFF VALVES IN THEIR INTAKE AND RETURN PORTS, OTHERS DO NOT. IF YOU DO NOT HAVE A SHUT OFF VALVE, BLOCK THE PORTS WITH A REMOVABLE PLUG TO PREVENT WATER FROM PASSING INTO AND THROUGH THE HOSES.**

---

### NOTE

For Pools with 1¼" or 1½" (32mm or 38mm) Diameter Unthreaded Hoses use the standard adapters.

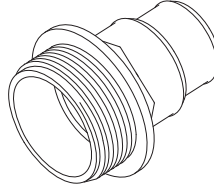

For Pools with 2¼" (57mm) Diameter Threaded Hose Connectors use the threaded adapters for Intex® pools.

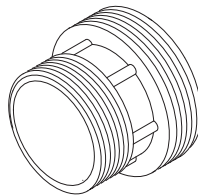

*These instructions assume that the pool is already assembled with hoses attached to the water intake and return ports on the pool.*

1. Attach a hose connector to the front of the strainer housing and the valve POOL port. Make certain that the 1½" (38mm) dia o-ring is in the adapter before securing.
2. Attach the pool outlet hose to the hose connector on the strainer housing. Refer to your pool manual if you are unsure about the inlet/outlet hoses. Secure hose with a hose clamp or thread onto the adapter.
3. Attach the pool return hose (inlet of pool) to the POOL port adapter on the 4 way valve. Secure hose with a hose clamp or thread onto the adapter.

**Note: Be sure not to secure the return hose to the waste/backwash port.**

4. Completed Filter-Pump Installation.

**IMPORTANT: Ensure ALL hose connections are tight and the hoses are NOT kinked or bent at severe angles. If the hoses are leaking, check to make sure ALL of the parts with o-rings have them attached and are screwed on tightly. DO NOT overtighten hose clamps (35 in/lb max torque).**

---

**CAUTION: DO NOT POWER PUMP AT THIS POINT.**

---

## FOR POOLS WITH 1¼" OR 1½" (32MM OR 38MM) DIAMETER UNTHREADED HOSES

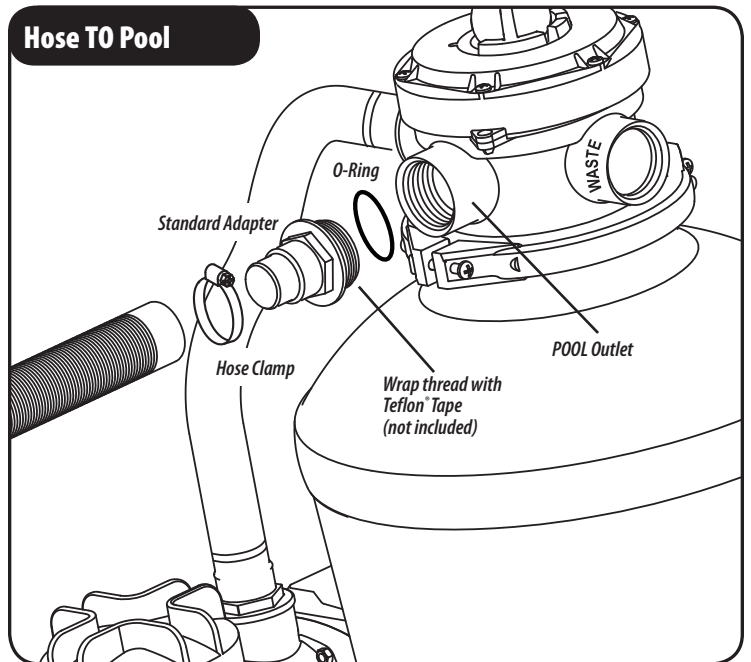
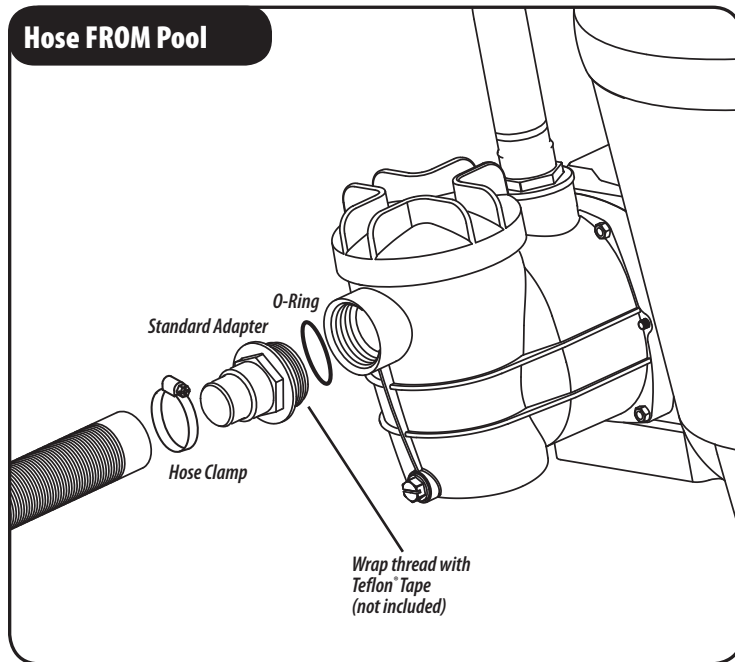

## FOR POOLS WITH 2¼" (57MM) DIAMETER THREADED HOSE CONNECTORS

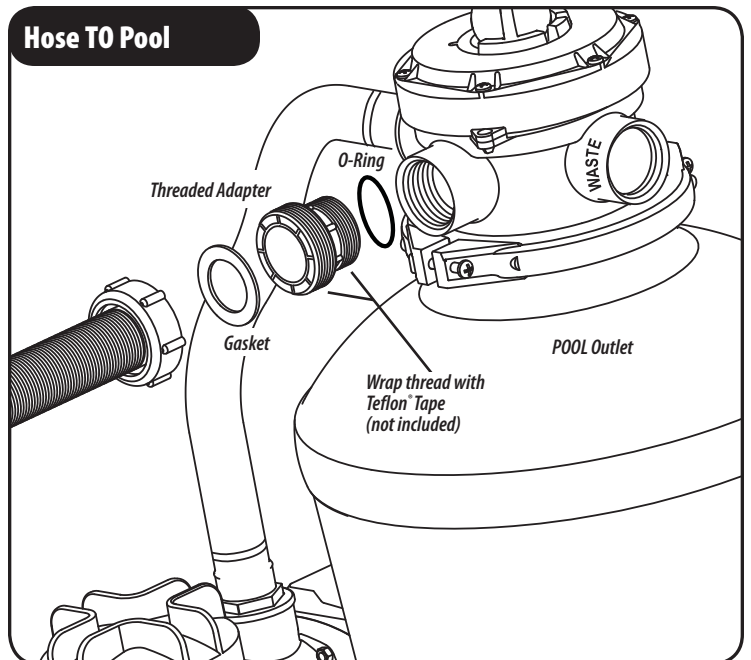
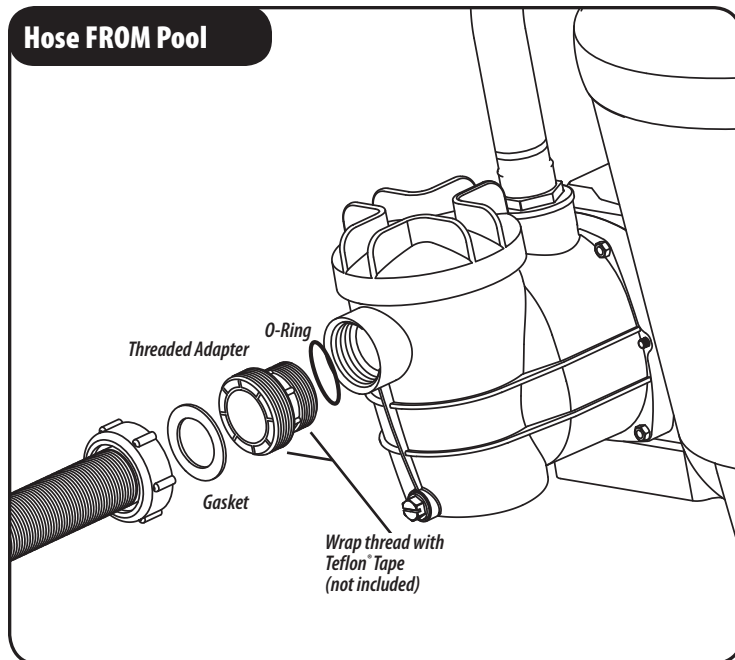

## 8. VALVE OPERATIONS

Make yourself familiar with your filter system's valve settings and functions.

### Filter Valve Settings & Functions

Setting	Complete Water Flow/Function
Filtration	Vacuum, regular pool filter action. This is the setting the filter will be set to most of the time. In this position, water is directed through the top of the filter where it compresses and flattens the sand. Contaminants are trapped by the sand as water makes it way to the bottom strainer, out of the filter and back to the pool.
Rinse	Rinse for no longer than 30 seconds right after backwashing to clean and resettle filter bed. This should always be done immediately after backwashing, new sand addition or filter start-up. In this position, water is directed to the top of the tank where it reseats the sand and flushes the valve while sending water out of the waste line. This reduces the chance of contaminant blow back to the pool when the valve is switched back to the filtration setting after backwashing. Run.
Backwash	Clean filter of captured debris. This is the position needed to clean the filter and sand. You'll know it is time to backwash when the pressure gauge rises (5 - 10 psi) above its normal reading s(5 - 10 psi) when the filter is clean. In this position, water is directed through the bottom strainer, reversing the flow through the tank. This causes the sand to separate and lift while releasing trapped debris out the waste line.
Winterize/ Drain	Bypass the filter. This position is ideal for vacuuming pools with large amounts of debris or after an algae treatment. In this position, water bypasses the filter and sends all the water and contaminants out of the waste line. <b>CAUTION: Running the pump in this position will drain water from your pool. Observe water level to prevent running the pump dry.</b>

### Changing Valve Positions

The 4 way valve is designed to provide the required flow rate for each action described above. Always make sure the power source to the filter is unplugged before changing valve positions. In other words, the pump should not be running when you change valve settings (i.e. moving from FILTRATION position to the BACKWASH position). Changing valve positions while the pump is running could result in irreparable damage to the valve and its inner workings. To change valve positions, press down firmly on the valve lever and rotate to the desired setting.

**IMPORTANT: ALWAYS unplug power source to pump before changing valve positions. Changing valve positions while the pump is running could result in irreparable damage to the valve and its inner workings.**

---

**CAUTION: NEVER USE THE VALVE LEVER AS A HANDLE TO CARRY OR LIFT THE FILTER.**

---

## 9. FILTER OPERATIONS

---

### Start Up

Once the filter system has been properly assembled, the sand chamber filled with sand and the hoses connected, you may begin with filtration. However, we recommend that you clean and prepare the new sand that is in the sand chamber first. Cleaning the sand prior to filtering your pool will remove most of the dust and tiny sand particles that may exist in the sand. If you move straight to filtering, these particles will end up in your pool.

### Cleaning the Sand

1. Disconnect the pump from the power source.
2. Start with the 4 way valve in the CLOSED position.
3. If you haven't done so already, fill your pool with water. Ensure that the water level is at least 1 - 2 inches (2.54 - 5.08cm) above the top of the hose intake and return ports in the pool.
4. Release the shut off valve at the intake port in the pool. If you plugged the intake port, remove the plug to allow the water to flow into the intake hose.
5. With the filter-pump system installed in a location level lower than your pool's water level – water will automatically flow into the filter system.
6. Allow the filter tank to fill with water.
7. Check for leaks and make any necessary adjustments.
8. Follow the backwash process below.

### Backwash Process

1. Disconnect the pump from the power source (if not disconnected already).
2. Remove Backwash Drain Plug.
3. Connect standard adapter to backwash port.
4. Attach backwash hose (not included) to adapter.
5. Place the 4 way valve in the BACKWASH position.
6. Reconnect to the power source.

---

### CAUTION: SEE SECTION 5, POWER SOURCE REQUIREMENTS

---

7. Run filter in backwash mode until discharge water is clear.
8. Disconnect the pump from the power source.
9. Place the 4 way valve in the RINSE position.
10. Reconnect to the power source.
11. Allow filter to run for 60 seconds to remove any remaining residue from pump and valve.
12. Disconnect the pump from the power source.
13. Place the 4 way valve in the FILTRATION position.
14. Reconnect to the power source.

Your filtration system is running and ready for further operation.

**NOTE: When the filter pump is properly connected to the power source, the pump will begin to push the water through the bed of sand and out of the backwash hose. In this process, water will be drained from your pool as it cleans the bed of sand within the tank. You may want to put a garden hose in the pool to add water while the pump is running so that the water level does not fall below the intake return ports. While the sand is being cleaned, run your fingers through the water exiting the backwash hose. When you can no longer feel or see sandy grit in the water, the sand cleaning process is complete.**

### Backwash Do's and Don'ts

Be aware and make note of the filter pressure when the sand is clean. Backwash when you see an increase of 5–10 psi on the pressure gauge.

- Do backwash long enough to get the job done right. Let the system backwash until the water exiting the waste line is clear. Note that backwashing can remove 50–300 gallons (189 - 1,135 liters) of water from your pool so pay attention. Also, be aware of local codes regarding pool water disposal as some communities outlaw drainage.
- Don't backwash excessively. Sand filters operate more efficiently during mid-cycle. Some level of debris in the sand bed actually helps filtration and makes the filter more effective. Too much backwashing will reduce efficiency.
- Don't vacuum the pool in backwash mode. This can plug up the strainer at the bottom of the filter which will result in inefficient operation. In addition, you may have to remove all of the sand to get it unclogged.

## 10. MAINTENANCE

The chart below outlines the recommended maintenance schedule for your Pool Filter System.

Intervals	Maintenance Items
Weekly	Backwashing, regardless of the pressure or how dirty the filter might be
	Cleaning of the Debris/Lint filter in the hair and lint strainer (directions below)
Annually	Winterize the system before the first frost (directions below)
	Add sand at the beginning of each swim season as needed

### Adding New Sand

**CAUTION: USE BREATHING FILTER/MASK APPROVED FOR DUST & SAND AND ADEQUATE EYE PROTECTION WHILE FILLING SAND CONTAINER. AVOID BREATHING IN DUST.**

1. Place the sand shield on the center stem of the manifold. This will ensure that when filling the tank, no sand will enter the manifold assembly.
2. Place 4 way valve in the RINSE position for 1 - 3 minutes after initial start up or after adding new sand. By doing this you can avoid blowing small particles and impurities from the new sand into your pool.

**CAUTION: BEFORE LOOSENING ANY THREADED CONNECTIONS ON THE FILTRATION SYSTEM, BE SURE THAT THE INTAKE AND RETURN HOSES ARE CLOSED OR PLUGGED TO PREVENT WATER FLOW OVER THE MOTOR.**

### Cleaning the Hair and Lint Filter

1. Disconnect the pump from the power source.
2. Close the shutoff valves or block the water flow at the pool intake and return ports.
3. Remove the trainer lid on the pump. Take out the strainer basket, clean it and replace it. Be sure to align the hole in the basket towards the front of the housing. Replace the lid and tighten. **DO NOT OVERTIGHTEN.**
4. Open the shutoff valves or unblock the water flow at the pool intake and return ports.
5. Place the 4 way valve in the FILTRATION position.
6. Reconnect to the power source.

**IMPORTANT: NEVER operate the pump without the hair and lint strainer basket in place – this can cause damage to the motor and pump assembly.**

### Winterizing the System

1. Disconnect the pump from the power source.
2. Close the shut off valves or block the flow of water at the pool intake and return ports.
3. Disconnect the filtration system from the pool, drain the tank and hoses.
4. Store the filter system in a location protected from frost and freezing temperatures.
5. Place valve handle in WINTER position for storage.

### Safety Notes

If there is any indication that safe operation is no longer possible, the device is to be disconnected from the power supply and secured against accidental use.

This is the case when:

- The device has visible damage
- The device no longer appears functional
- After long periods of storage in poor conditions
- Electrical components, cords, etc. appear frayed, worn or broken
- Guards or shields are missing or broken

## 11. TROUBLESHOOTING

Problem	Cause	Solution
Pressure is too low	Hair and lint strainer basket is dirty	Clean the hair and lint strainer.
Air in the pump	Poor seal on the intake side of the pump	Tighten hose clamps and connection fittings.
Water flows into the drainpipe	Dirt around the seal of the 4 way valve	Remove the 4 way valve from tank and clean the seal.
Leaking filter	Faulty Seal	Check the seal, replace if needed.
	Clamp not tight	Tighten clamp. DO NOT overtighten hose clamps (35 in/lb max torque).
Pump does not run	Not plugged in	Check the socket and power cord.
	GFCI/or main circuit breaker tripped	Switch on the breaker. If it is immediately tripped again, there is a defect in pump or controls.
	Faulty Pump Motor	Replace the pump/motor assembly.
Sand in pool	If the sand is newly replaced, the undersized grains are still present	Backwash several times until the backwash water is clear.
	Sand in central valve (from backwash)	Purge into drainpipe for 30 seconds.
	Filter's bottom strainer is damaged	Replace the filter bottom strainer.
Air in system	Water level is low or system recently opened for service	While pump is running, loosen, but do not remove, the pressure gauge or pressure gauge plug to release air. Then retighten the gauge or plug.

---

**REPAIRS ON THE PUMP SHOULD ONLY BE PERFORMED  
BY PROFESSIONALLY TRAINED, QUALIFIED TECHNICIANS.**

---



## 12. LIMITED WARRANTY STATEMENT

---

The manufacturer warranties safe operation and reliability only under the following conditions:

The filter system is installed and operated according to the assembly and operating instructions.

Only original replacement parts are used.

Consumable parts do NOT fall under the warranty

Expendable parts do NOT fall under the warranty. These include:

- All O-Rings
- Pressure Gauge
- Hair & Lint Strainer Basket
- Mechanical Seal, Complete
- Filter-to-Pump Hose

### General Terms

This Limited Warranty applies to the enclosed product (the "Product") distributed by Great American Duck Races, Inc., an Arizona corporation (doing business as Great American Merchandising and Events) ("GAME").

GAME warrants that the Product will be free from defects in materials and workmanship under normal use for a period of one (1) year from the date of purchase. (Your dated sales or delivery receipt, showing the date of your Product purchase, is your proof of the purchase date.) During the warranty period, GAME will repair or replace any defective parts, including freight, at no charge for the first ninety (90) days. After ninety (90) days, GAME will repair or replace defective parts at no charge, freight costs to be paid by the purchaser.

All defective parts that are replaced by GAME will be replaced, at GAME's discretion, with either new parts or used parts that meet or exceed performance specifications for new parts. All parts removed from the Product under this warranty will become the property of GAME. Repair or replacement of any parts will not serve to extend the one (1) year warranty period.

This Limited Warranty does not apply to expendable parts. This Limited Warranty does not extend to any product (a) from which the serial number has been removed or (b) that has been damaged or rendered defective (i) as a result of accident, misuse, abuse or other external causes; (ii) by operation outside the usage parameters stated in the manual that shipped with the Product; (iii) by the use of parts not manufactured or sold by GAME; or (iv) by modification or service by anyone other than GAME or an authorized GAME distributor.

If a defect is identified within the warranty period, please contact GAME.

**EXCEPT FOR THE LIMITED WARRANTY SET FORTH ABOVE, GAME EXPRESSLY DISCLAIMS ALL OTHER WARRANTIES, WHETHER EXPRESS OR IMPLIED, ORAL OR STATUTORY (INCLUDING, WITHOUT LIMITATION, WARRANTIES OF MERCHANTABILITY AND FITNESS FOR A PARTICULAR PURPOSE). ANY IMPLIED WARRANTIES THAT MAY BE IMPOSED BY LAW ARE LIMITED TO THE TERMS OF THE ABOVE LIMITED WARRANTY.**

### Limitation of Liability

**EXCEPT FOR THE LIMITED WARRANTY DESCRIBED ABOVE, IN NO EVENT WILL GAME HAVE ANY LIABILITY OF ANY KIND WHATSOEVER (WHETHER UNDER CONTRACT, TORT, OR ANY OTHER THEORY OF LEGAL LIABILITY) TO ANY PERSON WITH RESPECT TO THE PRODUCT (INCLUDING, WITHOUT LIMITATION, (A) ANY USE OR MISUSE OF THE PRODUCT, (B) ANY FAILURE OR MALFUNCTION OF THE PRODUCT, (C) ANY BODILY INJURY, DEATH, LOSS OF OR DAMAGE TO ANY PROPERTY, OR ANY OTHER DAMAGES RELATED TO OR RESULTING FROM THE PRODUCT OR ITS USE (INCLUDING, WITHOUT LIMITATION, ANY SPECIAL, INCIDENTAL, CONSEQUENTIAL OR PUNITIVE DAMAGES, LOST PROFITS, LOSS OF USE), EVEN IF GAME OR GAME'S AUTHORIZED REPRESENTATIVES HAVE BEEN ADVISED OF THE POSSIBILITY OF ANY SUCH DAMAGES.**

### Severability

Any provision of this Limited Warranty which is prohibited or unenforceable in any jurisdiction will, as to such jurisdiction, be ineffective to the extent of such prohibition or unenforceability without invalidating the remaining portions hereof or affecting the validity or enforceability of such provision in any other jurisdiction.

### Venue and Choice of Law

This Limited Warranty is applicable in all countries. This Limited Warranty will be governed by the laws of the State of Arizona (regardless of any conflict of laws rules), and any disputes arising from this Limited Warranty will be resolved in Phoenix, Arizona.

### Entire Agreement

This Limited Warranty is understood to be the complete and exclusive agreement between GAME and the purchaser of the Product, superseding all prior agreements, oral or written, and all other communications between such parties relating to the Product. No employee or representative of GAME or any other party is authorized to make any warranty in addition to the limited warranty set forth above.

**To obtain warranty service, please call, write, or email us at [products@game-group.com](mailto:products@game-group.com).**

**This warranty gives you specific legal rights, and you may also have other rights which vary from state to state.**

### 13. APPENDIX: EXPLODED PARTS DIAGRAM

Key	Part Name	Qty	Part
1	Pump/Motor Assembly	1	
	4S1063 (model 35D, item 4706) includes 1, 1A, 1B, 2, 3, 23		
	4S1064 (model 50D, item 4710) includes 1, 2, 3, 23		
	4S1065 (model 75D, item 4711) includes 1, 2, 3, 23		
1A	Strainer Housing (model 4706 only)	1	NA
1B	Housing Clip (model 4706 only)	1	NA
2	Strainer Basket	1	4S1057
3	Strainer Lid	1	4S1058
4	Filter tank	1	
	4S1060 (model 35D, item 4706)		
	4S1061 (model 50D, item 4710)		
	4S1062 (model 75D, item 4711)		
5	4 Way Valve	1	4S1050
6	Base Plate	1	4S1066
7	Flange Clamp	1	4S1053
8	Drain Plug Assembly	1	4S1054
9	Manifold	1	
	4S1051 ((model 35D, item 4706)		
	4S1068 (model 75D, item 4711)		
10	Tank Large O-Ring	1	4S1053
11	Hose Clamp	2	4S1052
12	Waste (Backwash) Plug	1	NA
13	Hose Adapter	5	4S1052
14	Hose Adapter O-Ring	3	4S1052
15	Short Intex Adapter	2	4S1067
16	Short Intex Adapter Gasket	2	4S1067
17	1 1/4" (32mm) Hose	1	4S1055
18	Sand Shield	1	NA
19	Pressure Gauge Plug	1	NA
20	Pressure Gauge	1	4S1056
21	Pump Mount Screw and Washer	4	4S1066
22	Flange Screw & Nut	2	4S1053
23	Pump Drain Plug & Gasket	1	4S1059

#### Item 4706

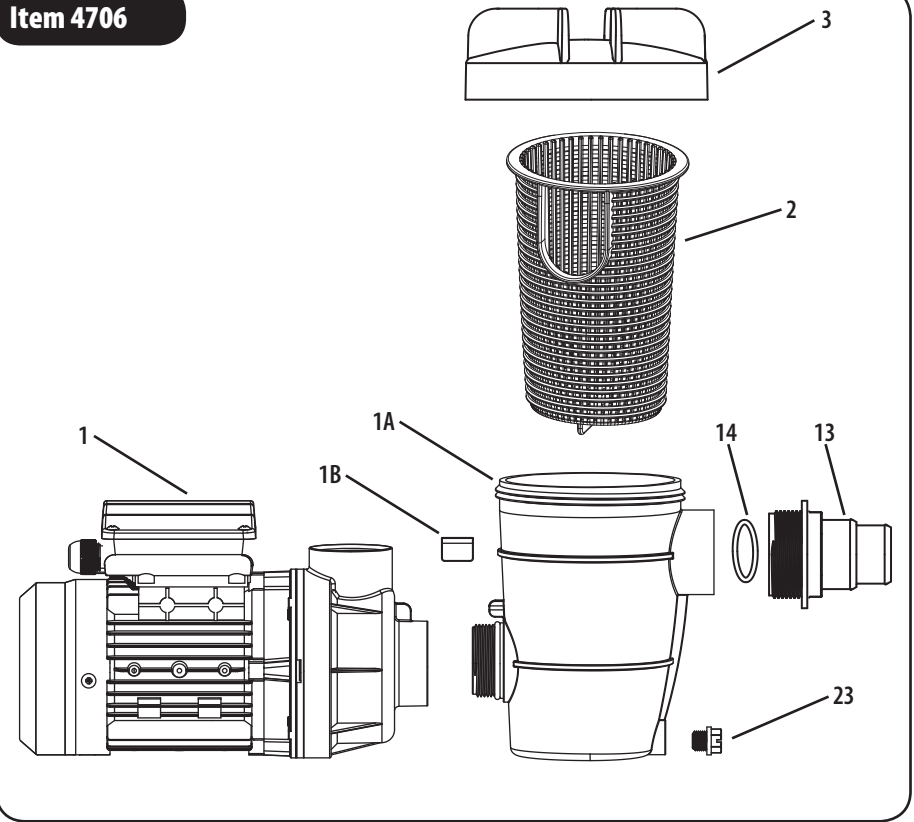

#### Items 4710, 4711 & 4728

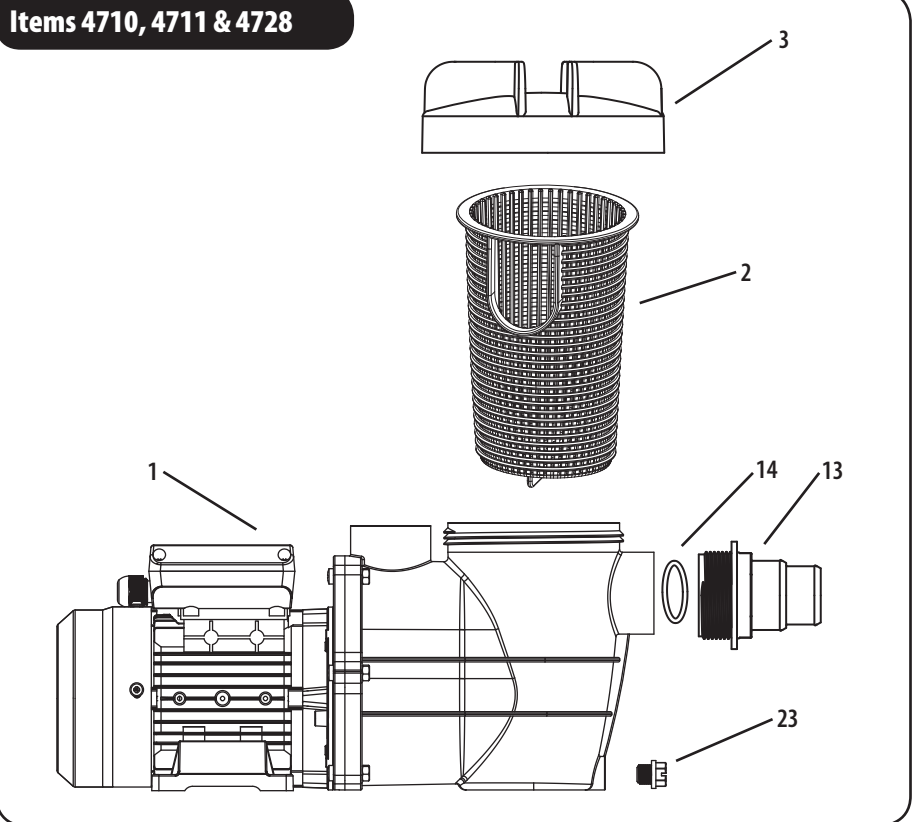

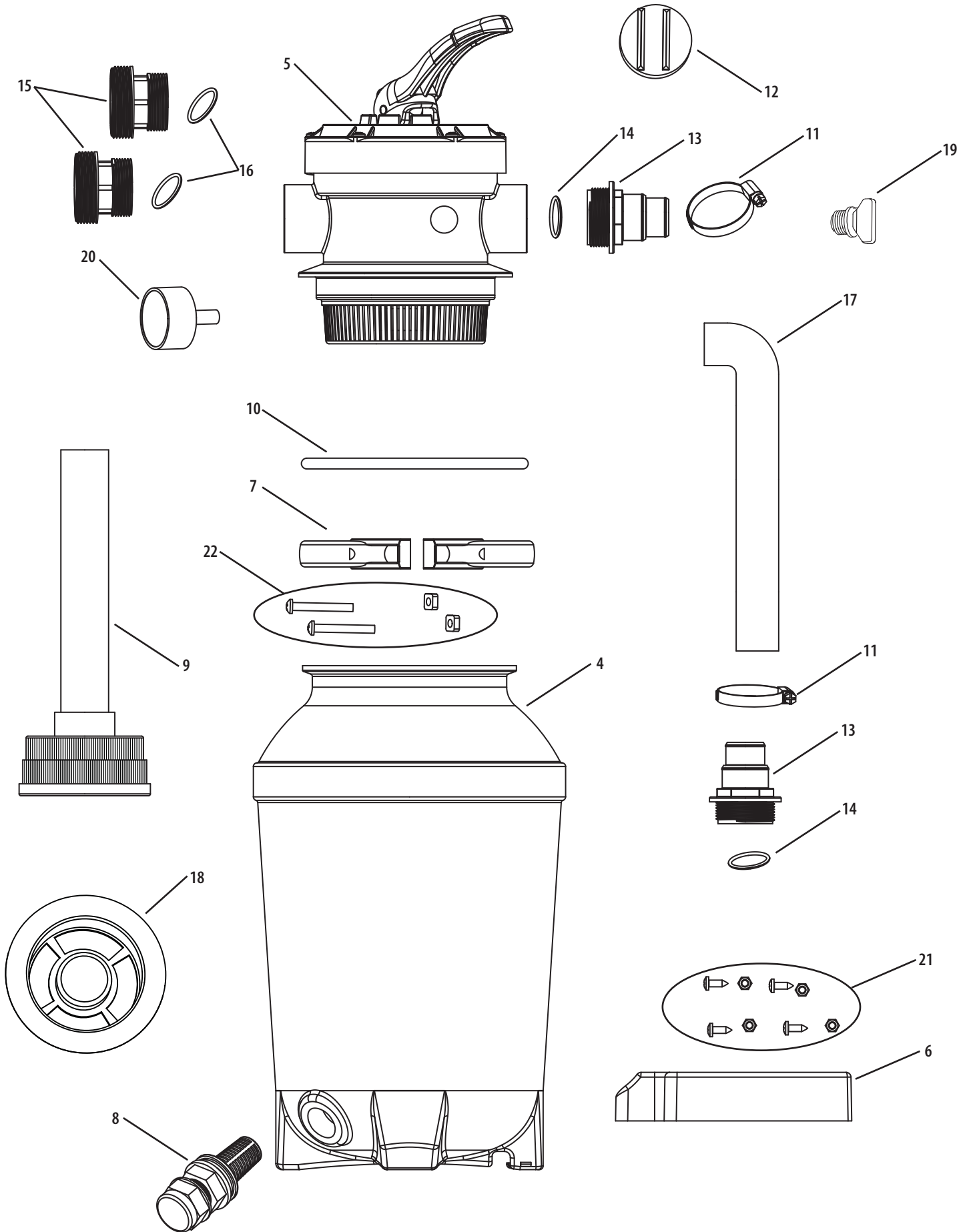

**IMPORTANT**  
**DO NOT RETURN PRODUCT TO STORE**

For technical assistance and missing parts, call Customer Service toll-free

**1.888.339.2546**

(press 135 at any time)

Monday through Thursday, 8:00 am to 5:00 pm MST

Friday, 8:00 am to 2:00 pm MST

---

Please visit our website, [www.game-group.com](http://www.game-group.com), for potential updates to these instructions.

---

**Look for other GAME products at your favorite store  
or visit our website, [www.game-group.com](http://www.game-group.com).**



/GAMEproducts



*The Fun Solutions People®*

Great American Merchandise & Events™  
16444 N. 91st Street  
Scottsdale, AZ 85260-1567 U.S.A.

tel: 888.382.5988, 602.957.3825  
fax: 602.957.7665  
email: [products@game-group.com](mailto:products@game-group.com)  
[www.game-group.com/retailers](http://www.game-group.com/retailers)

Intex® is a registered trademark of Intex Recreation Corp. GAME is not affiliated with, sponsored by, or otherwise associated with Intex Recreation Corp.

Bestway® is a registered trademark.