

levoit

USER MANUAL

Tower True HEPA Air Purifier

Model: LV-H133

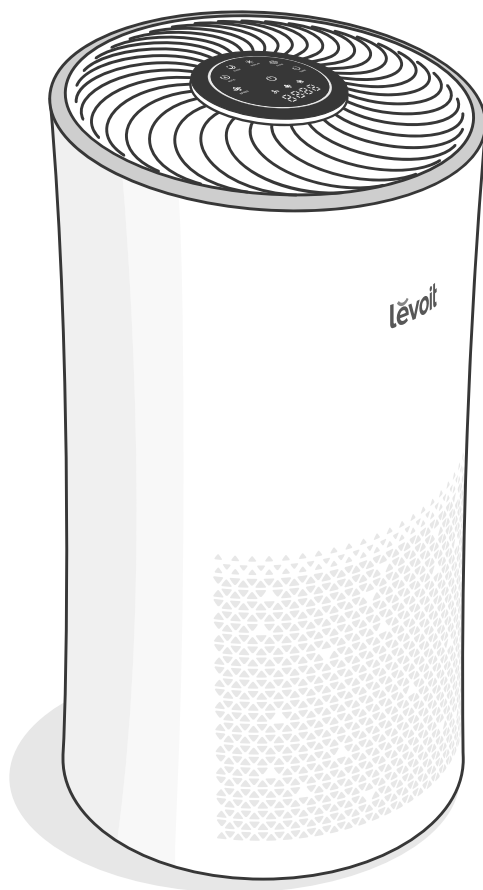

Questions or Concerns?

Please contact us Mon–Fri, 9:00 am–5:00 pm PST/PDT
at support@levoit.com or at **(888) 726-8520**.

Thank you for purchasing the
**TOWER TRUE HEPA AIR
PURIFIER BY LEVOIT.**

If you have any questions or concerns, please reach out to us at **support@levoit.com**. We hope you enjoy your new air purifier!

Find Us Online

Search for **@LevoitLifestyle** • **#LevoitLove** • **#LevoitLifestyle** on social media for tips, special deals, giveaways, inspiration, and more.

Table of Contents

Package Contents	3
Specifications	3
Safety Information	4
Getting to Know Your Air Purifier Controls	7
Getting Started	8
Using Your Air Purifier	9
About the Filter	11
Care & Maintenance	12
Troubleshooting	15
Warranty Information	17
Customer Support	18

Package Contents

1	x	Air Purifier
1	x	True HEPA Combination Filter (Pre-Installed)
1	x	User Manual

Specifications

Power Supply	AC 120V, 60Hz
Rated Power	47W
Effective Range	≤ 442 ft ² / 41 m ²
Operating Conditions	Temperature: 14°–104°F / -10°–40°C
	Humidity: ≤ 85% RH
Noise Level	25–54dB
CADR (Clean Air Delivery Rate)	466 m ³ /h / 274 CFM
Standby Power	< 0.8W
Dimensions	12.5 x 12.5 x 23.6 in / 31.8 x 31.8 x 60 cm
Weight	21 lb / 9.5 kg

READ AND SAVE THESE INSTRUCTIONS

SAFETY INFORMATION

To reduce the risk of fire, electric shock, or other injury, follow all instructions and safety guidelines.

General Safety

- **Only** use your air purifier as described in this manual.
- **Do not** use your air purifier outdoors.
- Keep your air purifier away from water, and wet or damp areas. **Never** place in water or other liquids.
- Keep your air purifier away from heat sources.
- **Do not** use where combustible gases, vapors, metallic dust, aerosol (spray) products, or fumes from industrial oil are present.
- Keep 5 ft / 1.5 m away from where oxygen is being administered.
- Supervise children when they are near the air purifier.
- **Do not** place anything into any opening on the air purifier.
- **Do not** sit or place heavy objects on the air purifier.
- Keep the inside of the air purifier dry. To prevent moisture buildup, avoid placing in rooms with major temperature changes.
- **Always** unplug your air purifier before servicing (for example, changing the filter).
- **Do not** use your air purifier if it is damaged or not working correctly, or if the cord or plug is damaged. **Do not** try to repair it yourself. Contact **Customer Support** (see page 18).

- **WARNING:** To reduce the risk of fire or electric shock, **do not** use this air purifier with any solid-state speed controls (such as a dimmer switch).
- Not for commercial use. Household use **only**.

Plug & Cord

- Keep the air purifier near the outlet it is plugged into.
- **Never** place the cord near any heat source.
- **Do not** cover the cord with a rug, carpet, or other covering. **Do not** place the cord under furniture or appliances.
- Keep the cord out of areas where people walk often. Place the cord where it will not be tripped over.
- Your air purifier has a polarized plug (one prong is wider than the other), which fits into a polarized outlet only one way. This is a safety feature to reduce the risk of electric shock. If the plug does not fit, reverse the plug. If it still does not fit, **do not** use the plug in that outlet. **Do not** bypass this safety feature.

GETTING TO KNOW YOUR AIR PURIFIER

Function Diagram

- A. LED Display / Control Panel
- B. Air Outlet
- C. Housing
- D. Power Cord
- E. Air Intake
(triangles at the bottom)
- F. Air Quality Sensor
- G. Air Quality Sensor Cover
- H. Filter
- I. Filter Cover

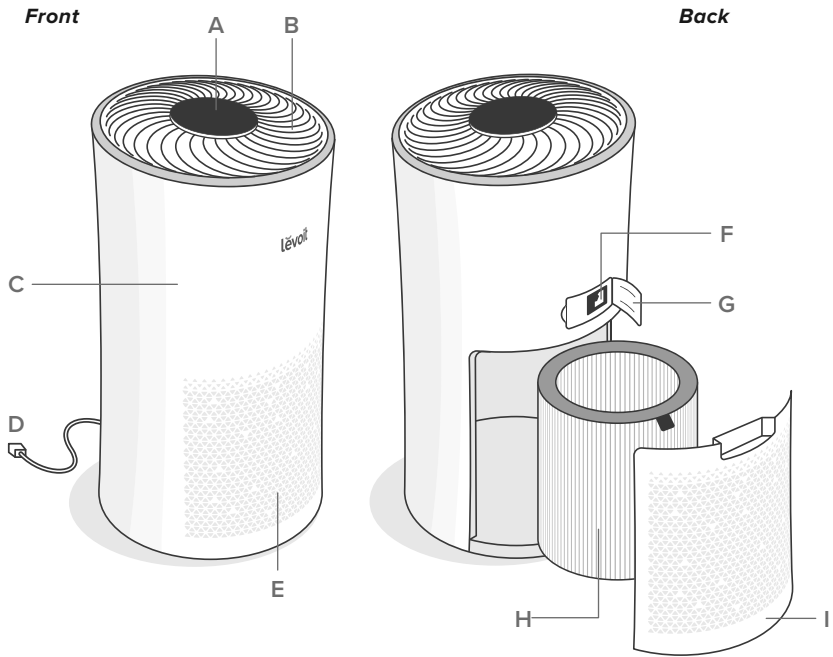

GETTING TO KNOW YOUR AIR PURIFIER (CONT.)

LED Display

- A. Fan Speed Button
- B. Auto Mode Button
- C. Sleep Mode Button
- D. Display Off Button
- E. Check Filter Indicator
- F. Timer Button
- G. On/Off Button
- H. Air Quality Indicator
- I. Timer Display
- J. Fan Speed Indicator



CONTROLS



On/Off Button

Turns the air purifier on/off.



Fan Speed Button

Cycles through fan speeds: low, medium, and high.

Fan Speed Indicator	Fan Speed
	Low
	Medium
	High



Auto Mode Button

Turns Auto Mode on/off (see page 9).



Sleep Mode Button

Turns Sleep Mode on/off (see page 10).



Display Off Button

- Turns the display off.
- Press any button (except) to turn the display back on.



Check Filter Indicator

Lights up red to remind you to check the filter (see page 12).



Timer Button

Sets the timer (see page 10).

GETTING STARTED

1. Remove the filter cover. Pull the filter from the housing. [Figure 1.1]
2. Take the filter out of its plastic packaging, then reinstall it into the housing. Make sure the pull tabs on the filter are facing out. [Figure 1.2]
3. Replace the filter cover by lining up the cover's feet with the slots in the bottom of the housing. [Figure 1.3]
4. Push the cover securely closed. [Figure 1.4]

Note:

- If you are not planning to use the air purifier for a long period of time, keep the filter clean by leaving it inside its plastic packaging until it is ready to be used.

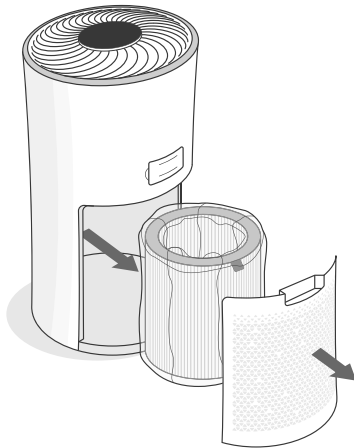

Figure 1.1

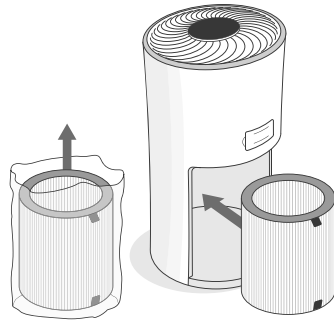

Figure 1.2

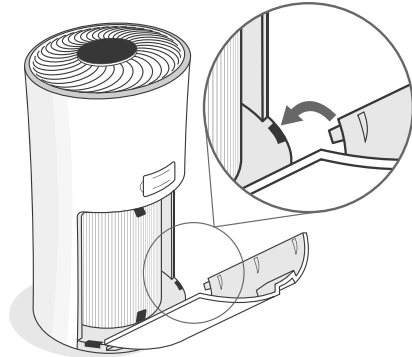

Figure 1.3

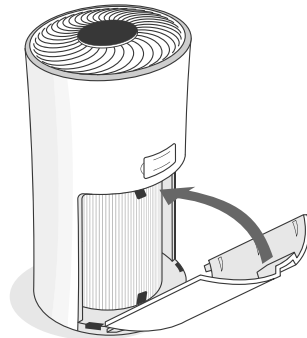





Figure 1.4

USING YOUR AIR PURIFIER

General Operation

1. Place the air purifier on a level surface. [Figure 2.1] Leave 15 in / 38 cm of clearance on all sides of the purifier. [Figure 2.2]
2. Plug in. Tap  to turn on the air purifier. The fan will start automatically.
3. Optionally, tap  to change fan speed. You can also select Auto Mode or Sleep Mode, or set a timer.
 - a. For best results, or to address a specific air quality issue such as smoke, run the air purifier at high speed for 15–20 minutes before using a lower speed or Auto Mode.
 - b. To effectively clean air, keep windows and doors closed while the air purifier is on.
4. Tap  to turn off the air purifier.

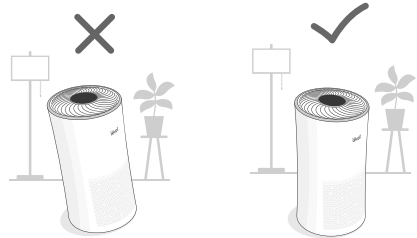

Figure 2.1

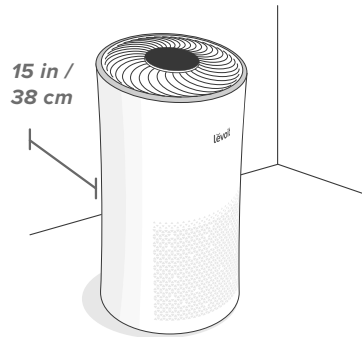





Figure 2.2

Auto Mode

Auto Mode adjusts the fan speed automatically based on air quality. For example, if the air quality is bad, the fan will be set to high speed.

- Tap  to turn Auto Mode on/off.
- Tapping  or  will also exit Auto Mode.

Air Quality Indicator Chart		
Indicator Color	Air Quality	Fan Speed
Blue	Very Good	Sleep Mode
Green	Good	Low
Orange	Moderate	Medium
Red	Bad	High

Air Quality Indicator



This indicator uses an automatic sensor to display the air quality. This sensor uses an infrared light to detect airborne particles

The air purifier will take 30 seconds to detect the air quality each time it is turned on. During this time, the air quality indicator color will be blue. After 30 seconds, the air quality indicator color will change based on the detected air quality.

USING YOUR AIR PURIFIER (CONT.)



Sleep Mode

Sleep Mode uses the lowest possible fan speed to operate quietly.

- Tap  to turn Sleep Mode on/off.
- Tapping  or  will also exit Sleep Mode.

Timer

You can set a timer between 1–12 hours.

1. Tap  repeatedly (or press and hold ) to set a time.
2. Once you choose a time, the timer will flash 5 times and start counting down.
3. The air purifier will automatically power off once the timer is finished.
4. To cancel a timer, tap  repeatedly until the timer reads “- - - -”. The timer will flash 5 times to confirm cancellation.

Note:

- *You can change the fan speed at any time while the timer is counting down. The timer will work with any mode.*
- *Pressing  or unplugging the air purifier will cancel the timer.*

Memory Function

The air purifier will remember its programmed settings while turned off and resume those settings when turned back on. The air purifier must remain plugged in for the memory function to work.

Note: *The air purifier will not remember timers.*

ABOUT THE FILTER

The True HEPA Combination Filter uses a 3-stage filtration system to purify air.

A. Nylon Pre-Filter

- Captures large particles such as dust, lint, fibers, hair, and pet fur.
- Maximizes the life of the True HEPA Filter by protecting it.

B. True HEPA Filter

- Removes at least 99.97% of airborne particles as small as 0.3 micrometers (μm) in diameter.
- Traps fine particles such as dust mites, pet dander, mold spores and pollen.

Note: Levoit air purifiers reduce airborne particles 0.3 microns or larger and make no claims to help reduce COVID-19 viruses.

C. High-Efficiency Activated Carbon Filter

- Physically adsorbs smoke, odors, and fumes.
- Filters compounds such as formaldehyde, benzene, ammonia, hydrogen sulfide, and volatile organic compounds (VOCs).

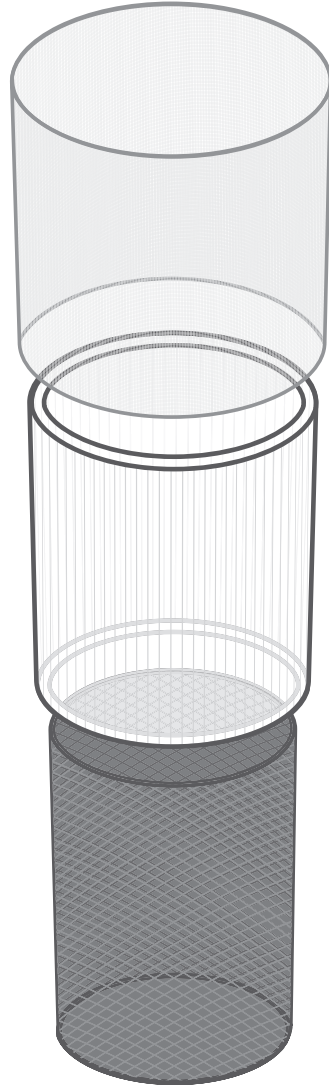

CARE & MAINTENANCE

Cleaning the Air Purifier

1. Wipe the outside of the air purifier with a dry cloth. **Do not** clean with water or any other liquid, to avoid risk of electric shock.
2. Clean the outside of the filter with a brush or vacuum hose each month to prevent buildup of hair or dust. Do not clean the filter with water or other liquids.

Cleaning the Air Quality Sensor

If the air quality sensor is blocked by accumulated dust, the air quality indicator may not work correctly.

1. Unplug the air purifier.
2. Open the sensor cover.
3. Clean the sensor lens with a damp cotton swab. [Figure 3.1]
4. Dry the sensor lens with a dry cotton swab.
5. Close the sensor cover.

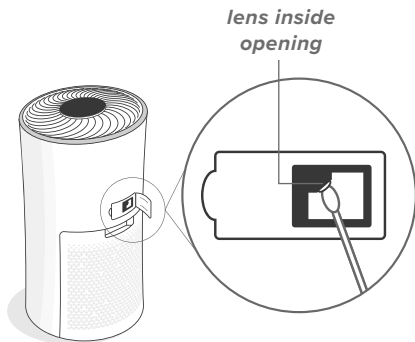

Figure 3.1



Check Filter Indicator

The icon will light up as a reminder to check the filter. The indicator is automatic. You may not need to change your filter yet, but you should check it when the icon lights up.

Resetting the Check Filter Indicator

Reset the Check Filter Indicator when:

- The icon lights up.
 1. Replace the filter (see page 13).
 2. Turn on the air purifier.
 3. Press and hold the icon for 3 seconds.
 4. The light will turn off after the filter indicator is successfully reset.
- The filter was changed before the icon lit up.
 1. Press and hold the icon for 3 seconds until the icon lights up.
 2. Press and hold the icon again for 3 seconds.
 3. The light will turn off after the filter indicator is successfully reset.

Storage

If not using the air purifier for an extended period of time, wrap the filter in plastic packaging and store in a dry place to avoid moisture damage.

CARE & MAINTENANCE (CONT.)

When Should I Replace the Filter?

The filter should be replaced every 6–8 months. You may need to replace your filter earlier or later depending on how often you use your air purifier. Using your air purifier in an environment with relatively high pollution may mean you will need to change the filter more often, even if  is off.

You may need to replace your filter if you notice:

- Increased noise when the air purifier is on
- Decreased airflow
- Unusual odors
- A visibly clogged filter

Note: To maintain the performance of your air purifier, **only** use official Levoit filters. To buy replacement filters, visit Levoit's online store. Go to [levoit.com](https://www.levoit.com) for more information.

Replacing the Filter

1. Unplug the air purifier, then remove the filter cover. [Figure 4.1]

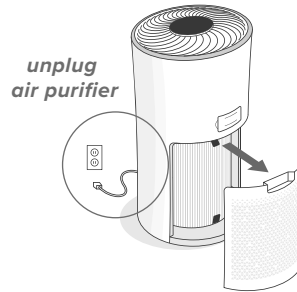

Figure 4.1

2. Remove the old filter. [Figure 4.2]

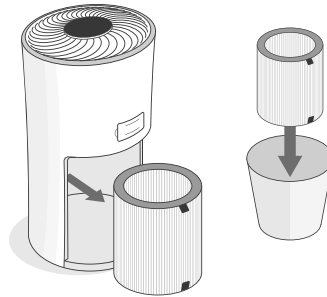

Figure 4.2

CARE & MAINTENANCE (CONT.)

3. Clean any dust or dirt from inside the housing. [Figure 4.3]

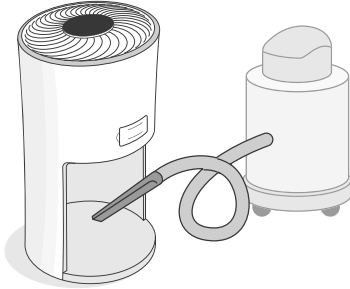



Figure 4.3

5. Replace the filter cover onto the housing. [Figure 4.5]
6. Plug in and turn on the air purifier. Press and hold  for 3 seconds to reset it.

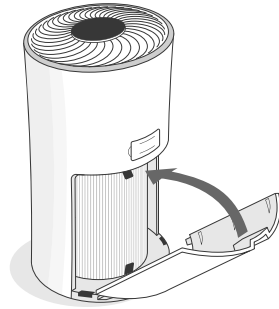

Figure 4.5

4. Unwrap the new filter and place it into the housing. Make sure the pull tabs are facing out. [Figure 4.4]

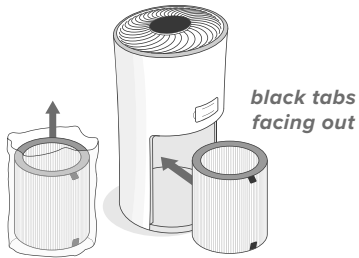











Figure 4.4

TROUBLESHOOTING

Problem	Possible Solution
Air purifier will not turn on or respond to button controls.	Plug in the air purifier.
	Check to see if the power cord is damaged. If it is, stop using the air purifier and contact Customer Support (see page 18).
	Plug the air purifier into a different outlet.
	Air purifier may be malfunctioning. Contact Customer Support (see page 18).
Air purifier makes an unusual noise when the fan is on.	Make sure the filter is properly in place with plastic packaging removed (see page 8).
	Replace the filter (see page 13).
	Air purifier may be damaged, or a foreign object may be inside. Stop using the air purifier and contact Customer Support (see page 18). Do not try to repair the air purifier.
Airflow is significantly reduced.	Make sure the filter's plastic packaging is removed.
	Tap  to increase the fan speed.
	Leave at least 15 in / 38 cm of clearance on all sides of the air purifier.
	Replace the filter (see page 13).
Poor air purification quality.	Tap  to increase the fan speed.
	Make sure no objects are blocking the top or sides of the air purifier for proper airflow.
	Close doors and windows while running the air purifier.
	Make sure the filter is removed from its plastic packaging and properly in place (see page 8).
	Make sure the room is smaller than $\leq 442 \text{ ft}^2 / 41 \text{ m}^2$. The air purifier may not be as effective in larger rooms.
	Replace the filter (see page 13).

TROUBLESHOOTING (CONT.)

Problem	Possible Solution
The air purifier is producing an unpleasant odor.	<p>Replace the filter (see page 13).</p> <p>Make sure that the air purifier is in a room where the relative humidity is less than 85% RH. Higher humidity levels may cause mildew to grow on the filter.</p>
 is still illuminated after replacing the filter.	Reset  (see page 12).
 has not turned on within 8 months.	 is a reminder for you to check the filter and will light up based on how much the air purifier has been used (see page 12). If you don't use your air purifier often,  will take longer to turn on.
 turned on before 6 months.	 is a reminder for you to check the filter and will light up based on how much the air purifier has been used (see page 12). If you run your air purifier frequently,  will turn on sooner.

If your problem is not listed, please contact **Customer Support** (see page 18).

WARRANTY INFORMATION

Product Name	Tower True HEPA Air Purifier
Model	LV-H133
Default Warranty Period	1 year
<i>For your own reference, we strongly recommend that you record your order ID and date of purchase.</i>	
Date of Purchase	
Order ID	

Terms & Policy

Arovast Corporation warrants all products to be of the highest quality in material, craftsmanship, and service, effective from the date of purchase to the end of the warranty period.

Arovast Corporation will replace any product found to be defective due to manufacturer flaws based on eligibility. Refunds are available within the first 30 days of purchase. Refunds are only available to the original purchaser of the product. This warranty extends only to personal use and does not extend to any product that has been used for commercial, rental, or any other use for which the product is not intended. There are no warranties other than the warranties expressly set forth with each product.

This warranty is non-transferrable. Arovast Corporation is not responsible in any way for any damages, losses, or inconveniences caused by equipment failure by user negligence, abuse, or use noncompliant with the user manual or any additional safety, use, or warnings included in the product packaging and manual.

This warranty does not apply to the following:

- Damage due to abuse, accident, alteration, misuse, tampering, or vandalism.
- Improper or inadequate maintenance.
- Damage in return transit.
- Unsupervised use by children under 18 years of age.

Arovast Corporation and its subsidiaries assume no liability for damage caused by the use of the product other than for its intended use or as instructed in the user manual. Some states do not allow this exclusion or limitation of incidental or consequential losses so the foregoing disclaimer may not apply to you. This warranty gives you specific legal rights and you may also have other rights which may vary from state to state.

ALL EXPRESSED AND IMPLIED WARRANTIES, INCLUDING THE WARRANTY OF MERCHANTABILITY, ARE LIMITED TO THE PERIOD OF THE LIMITED WARRANTY.

Extend Your Warranty by 1 Year

Register your product at www.levoit.com/warranty to extend your 1-year warranty by an additional year.

Please fill out all required fields and include your order ID, place of purchase, and purchase date, if applicable.

Defective Products & Returns

If you discover your product is defective within the specified warranty period, please contact Customer Support via support@levoit.com with a copy of your invoice and order ID. **DO NOT** dispose of your product before contacting us. Once our Customer Support Team has approved your request, please return the product with a copy of the invoice and order ID.

CUSTOMER SUPPORT

If you encounter any issues or have any questions regarding your new product, feel free to contact our helpful Customer Support Team.

Arovast Corporation

1202 N. Miller St., Suite A
Anaheim, CA 92806

Email: support@levoit.com

Toll-Free: (888) 726-8520

Support Hours

Mon–Fri, 9:00 am–5:00 pm PST/PDT

*Please have your order invoice and order ID ready before contacting Customer Support.

Connect with us @LevoitLifestyle



lěvoit

levoit.com

JJ0320MC-M1_0320LV-H133