



GOOD GRIPS®

V-Blade Mandoline Slicer



OXO's very versatile V-Blade Mandoline slices fruits and vegetables with ease. Familiarize yourself with its variety of blades and cutting options. For safe operation, always use the Food Holder.

CAUTION!

The OXO GOOD GRIPS V-Blade Mandoline Slicer blades are very sharp. Handle them with care when using the Mandoline and when cleaning the components. Always use the Food Holder to prevent injury. Do not leave the OXO V-Blade Mandoline or any components within reach of children.



GOOD GRIPS®

V-Blade Mandoline



I. What's Included	pg. 2
II. Quick Start Guide to Slicing	
a. Straight or Crinkle Cutting	5
b. Julienning or French Frying	6
III. Use & Care	
a. Switching V-Blades	8
b. Switching Julienne Blades	10
c. Disassembly & Cleaning	12
d. Reassembly & Storage	15
IV. Accessories	17

WHAT'S INCLUDED

MAIN BODY

A ▶
Mandoline Body

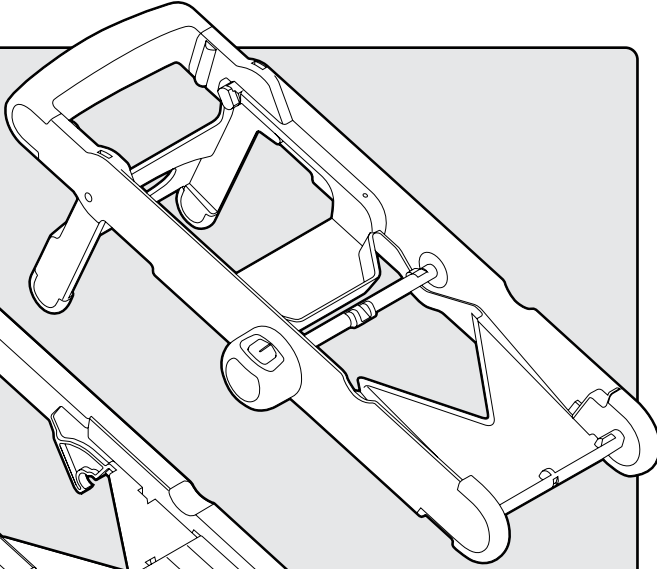

B ▶
Bottom Runway/
Under Deck Storage

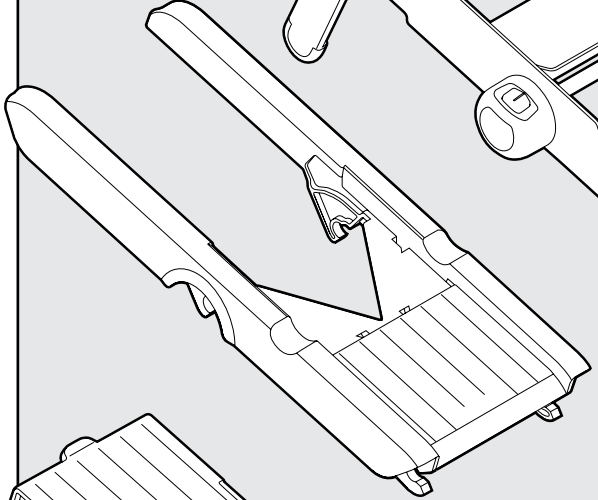

C ▶
Top Runway/
Under Deck Storage

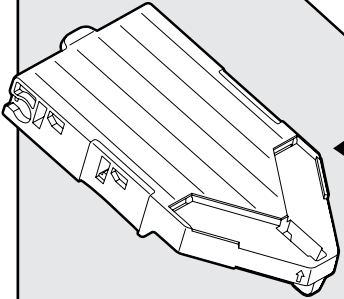

D ▶
Slicing Insert

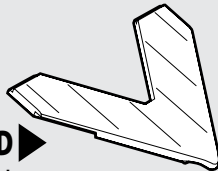

E ▶
Straight V-Blade

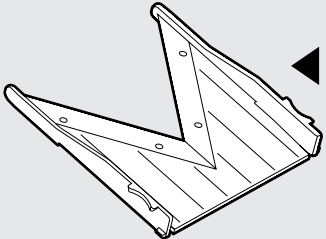

F ▶
Crinkle V-Blade

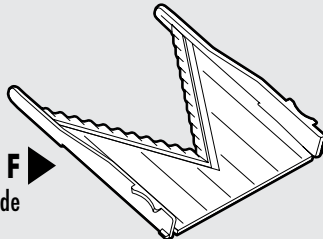

JULIENNE BLADES

G ▶
Julienne Blade (3 mm)

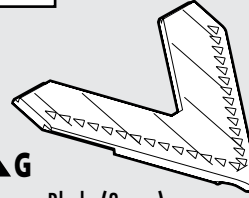

H ▶
French Fry Blade (6 mm)

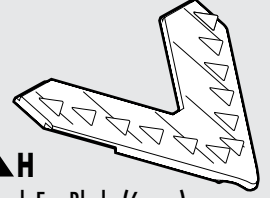

FOOD HOLDER

I ▶
Food Holder

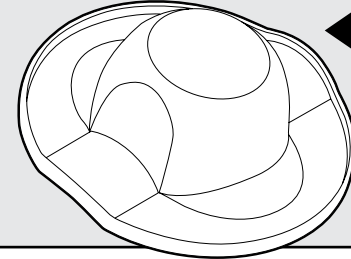

QUICK START GUIDE TO SLICING

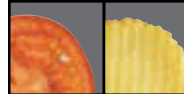

STRAIGHT OR CRINKLE CUTTING

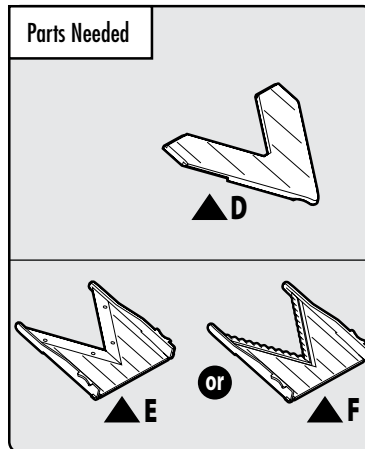

Straight or crinkle cutting requires slicing insert (D) and either the straight V-Blade (E) or the crinkle V-Blade (F). (For details on switching blades, see pg. 8.)

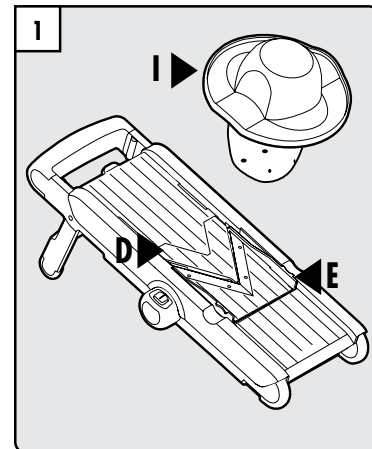

Load slicing insert (D) and either the straight V-Blade (E) or crinkle V-Blade (F) into mandoline. Secure food onto food holder (I).

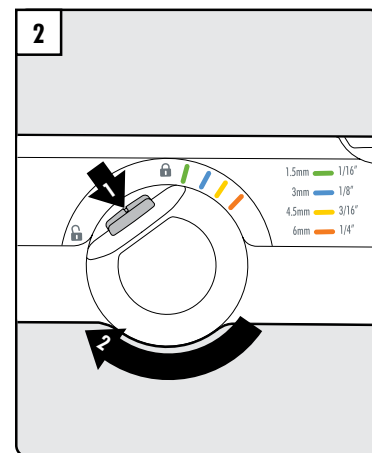

Press button on dial and turn to select desired slice thickness.

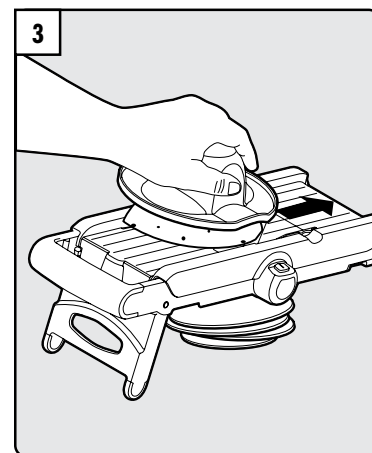

Using food holder (I), run food over blade to make slices.



JULIENNING OR FRENCH FRYING

Parts Needed

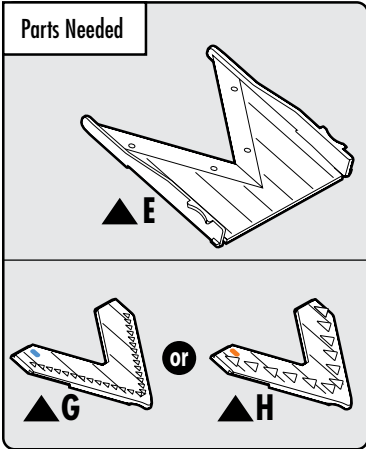

Julienning requires straight V-Blade (E) and either the julienne blade (G) or French fry blade (H). (For details on switching blades, see pg. 8 for straight blade and pg. 10 for julienne and French fry blades.)

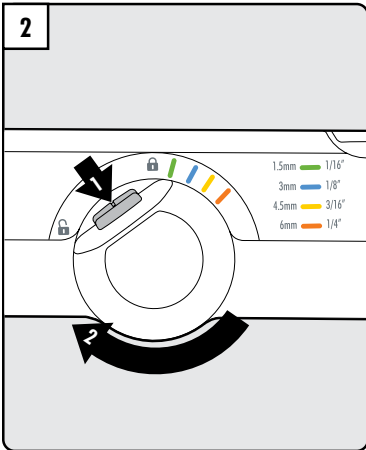

Press button on dial and turn to select the required slice thickness. (Both julienne and French fry blades are color coded to correspond with the dial settings.)

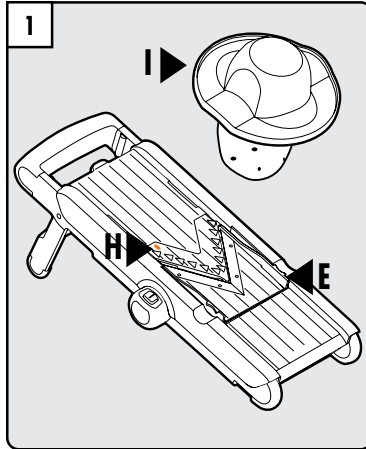

Load straight V-Blade (E) and either the julienne blade (G) or French fry blade (H) into mandoline. Secure food onto food holder (I).

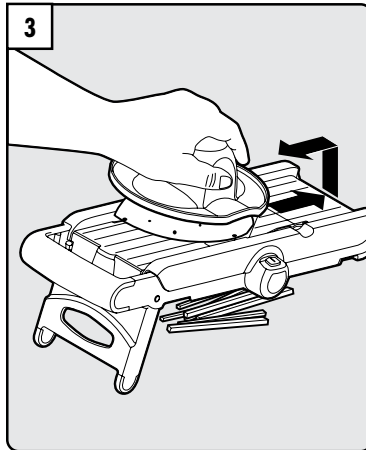

Using food holder (I), run food over blades to make julienne slices. Lift food off mandoline and return to starting position between cuts.

USE & CARE

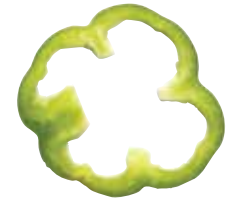

SWITCHING V-BLADES

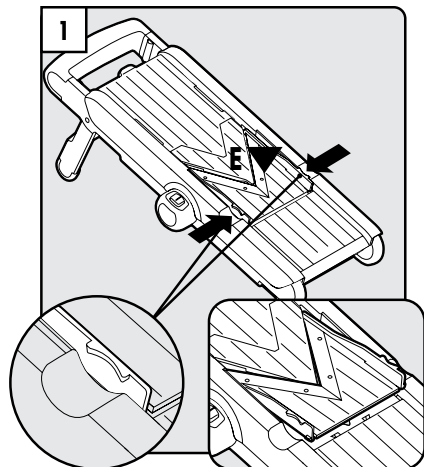

Pinch tabs of straight V-Blade (E) until it releases.

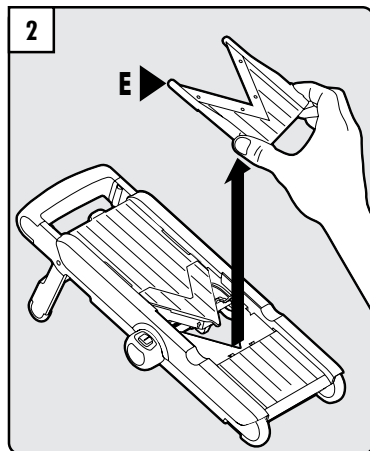

Remove straight V-Blade (E).

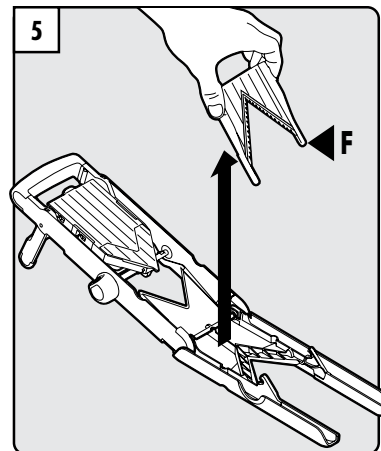

Remove crinkle V-Blade (F) from storage.

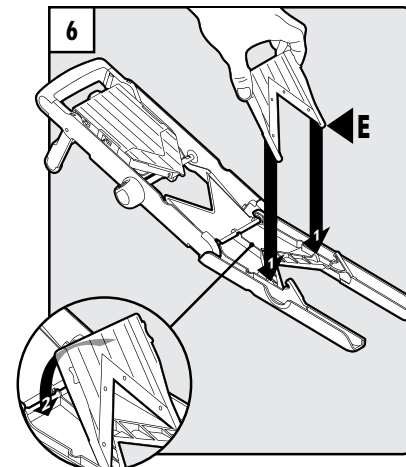

Place straight V-Blade (E) in storage by first sliding tips into sockets then pressing down V-Blade until it catches.

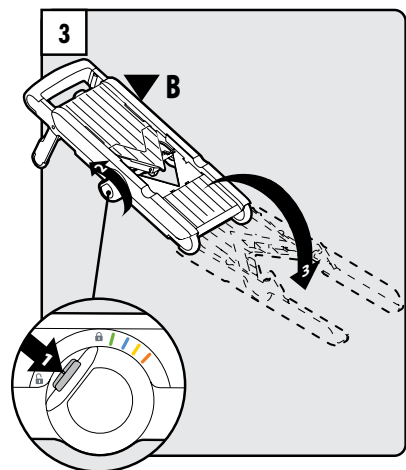

Press button on dial and turn to unlock position. Flip open bottom runway (B).

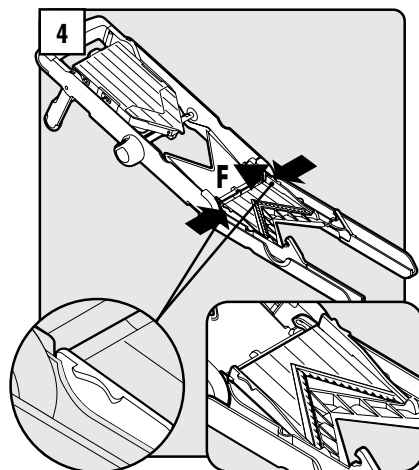

Pinch tabs of crinkle V-Blade (F) in storage until it releases.

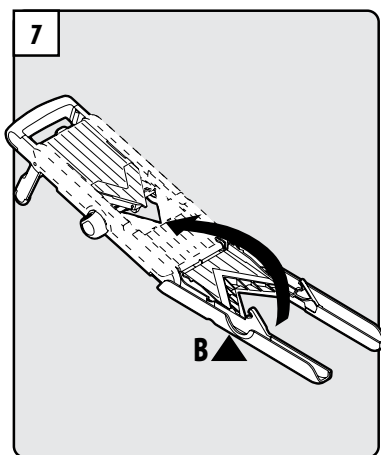

Flip close bottom runway (B).

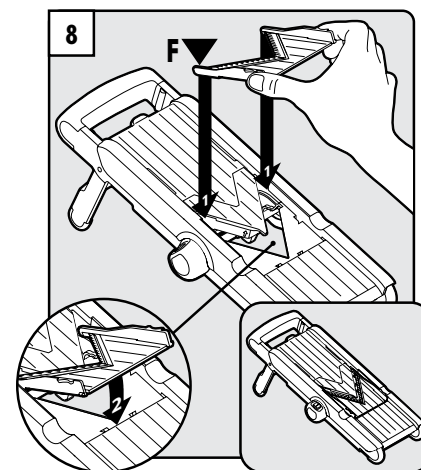

Insert crinkle V-Blade (F) by first sliding tips into side ramps then pressing down V-Blade until it catches.

SWITCHING JULIENNE BLADES

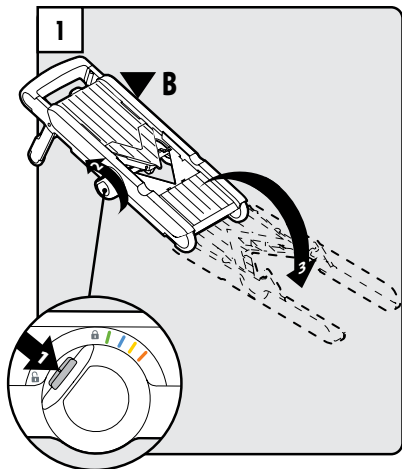

Press button on dial and turn to unlock position.
Flip open bottom runway (B).

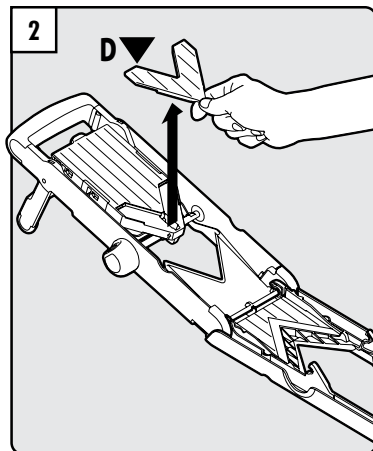

Remove slicing insert (D) by pulling up tip.

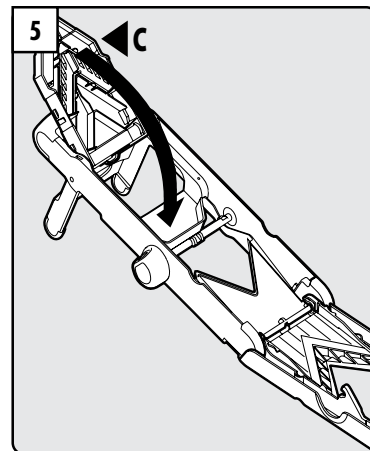

Flip close top runway (C).

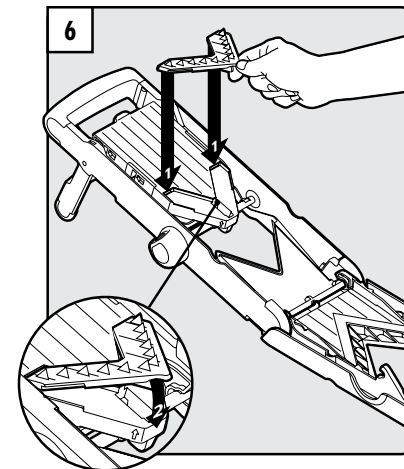

Insert desired julienne blade (G) or French fry blade (H) by first sliding in ends then pressing down tip until it snaps into place.

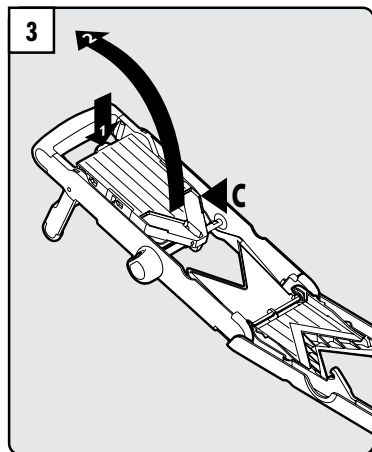

Flip open top runway (C) by pressing tab at top.

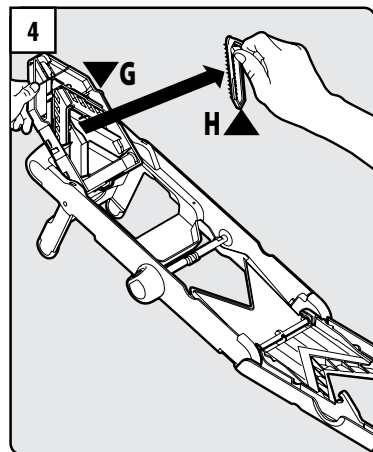

Release desired julienne blade (G) or French fry blade (H) from under deck storage by pulling respective tab.

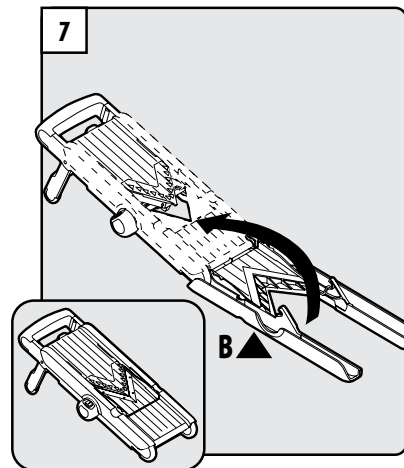

Flip close bottom runway (B).

DISASSEMBLY & CLEANING

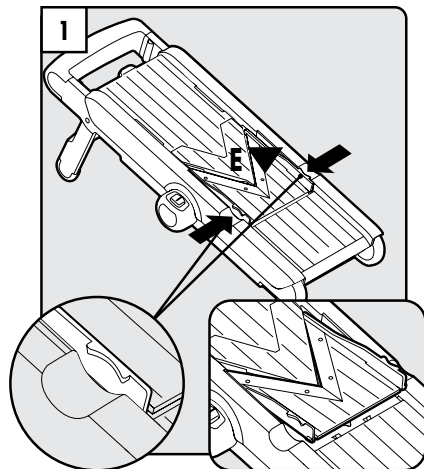

Pinch tabs of straight V-Blade (E) until it releases.

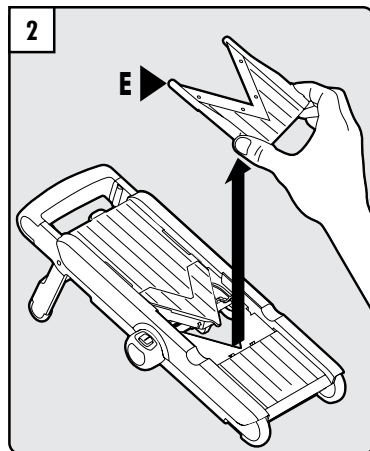

Remove straight V-Blade (E).

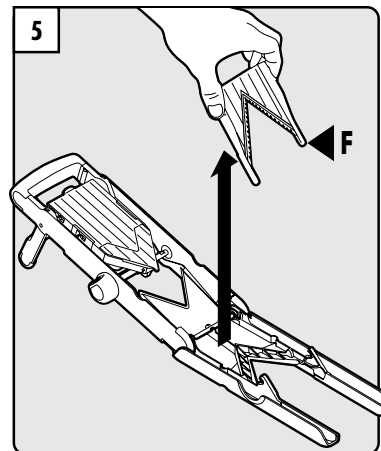

Remove crinkle V-Blade (F) from storage.

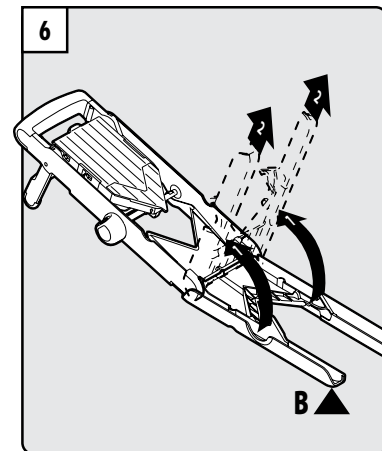

Flip up bottom runway (B) and remove by pulling straight up and off.

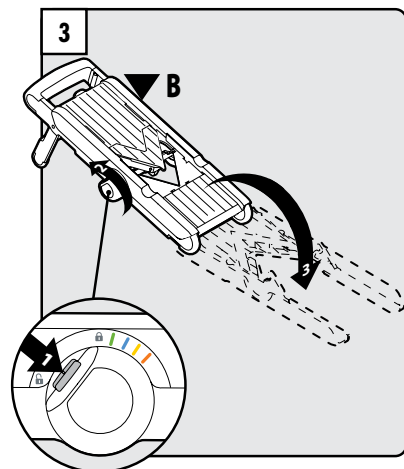

Press button on dial and turn to unlock position. Flip open bottom runway (B).

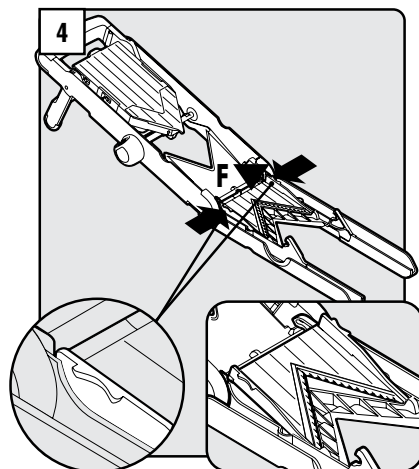

Pinch tabs of crinkle V-Blade (F) in storage until it releases.

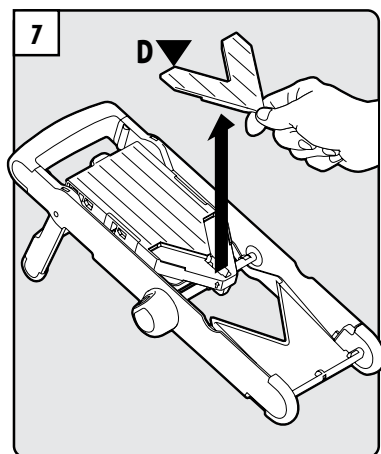

Remove slicing insert (D) by pulling up tip.

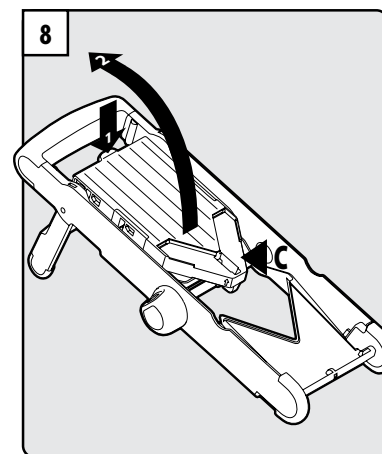

Flip open top runway (C) by pressing tab at top.

REASSEMBLY & STORAGE

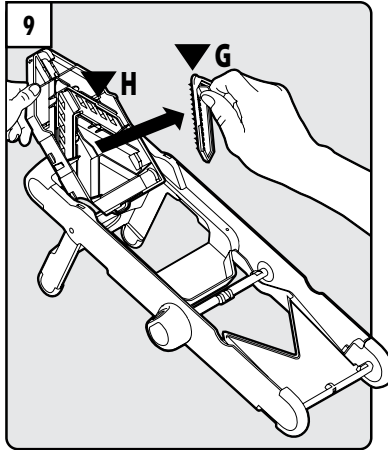

Pull tabs to remove both julienne blade (G) and French fry blade (H) from under deck storage.

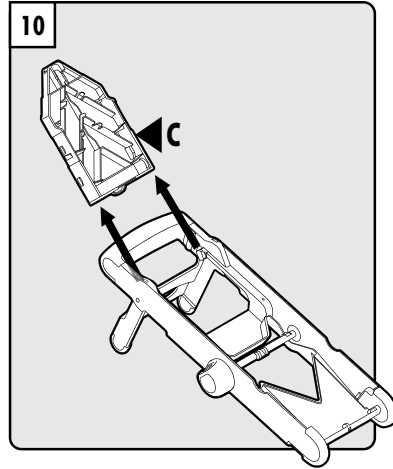

Slide out top runway (C) in fully open position.

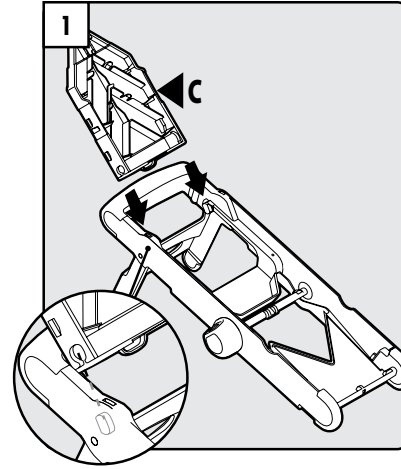

Attach top runway (C) by sliding into tabs in fully open position.

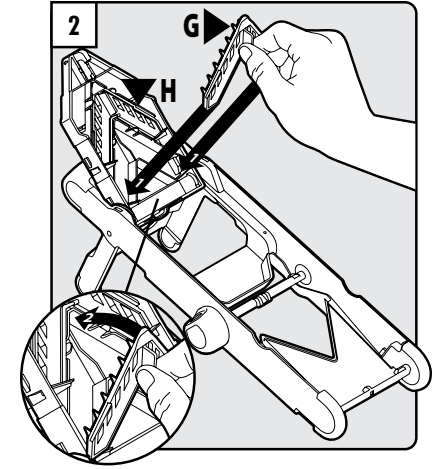

While top runway (C) is open, attach both julienne blade (G) and French fry blade (H) to under deck storage by first inserting bottom ends then snapping in top.

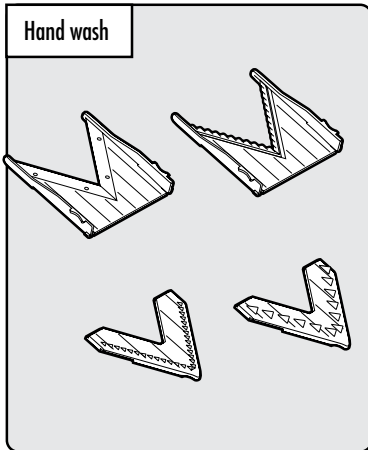

Hand wash blades.

CAUTION: Blades are sharp. Wash with care.

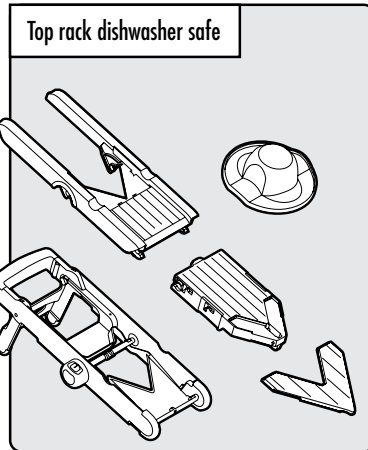

Wash all other parts in top rack of dishwasher.

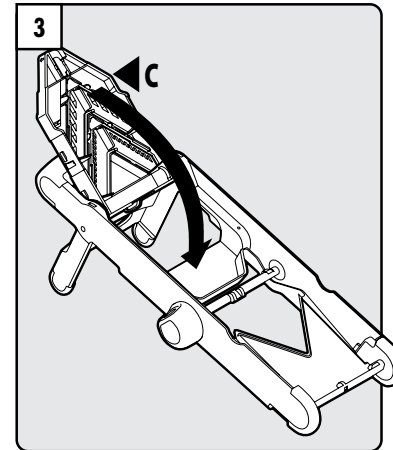

Flip close top runway (C).

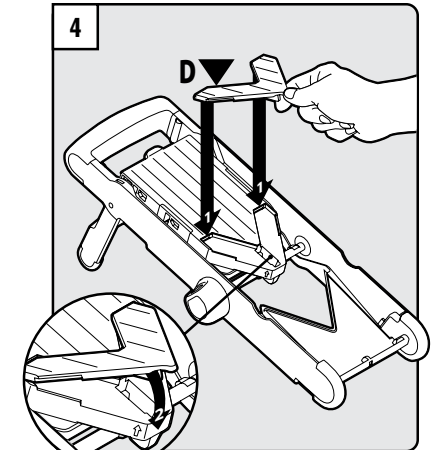

Attach slicing insert (D) by first inserting ends then snapping down tip.

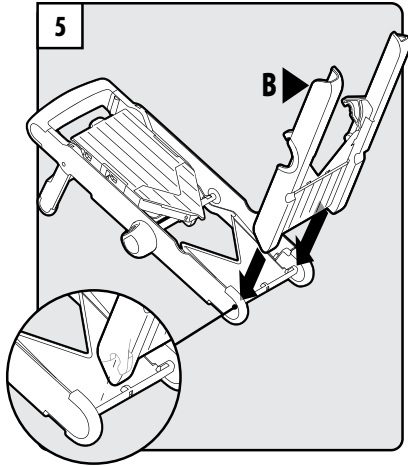

Attach bottom runway (B) by keeping upright and sliding hooks onto pivot bar.

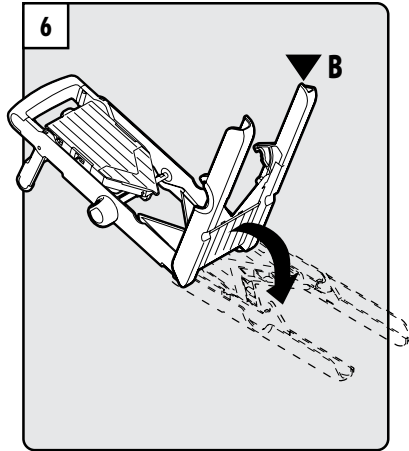

Flip open bottom runway (B).

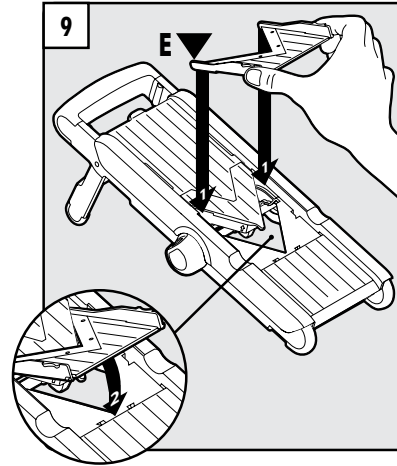

Insert straight V-Blade (E) by first sliding tips into side ramps then pressing down V-Blade until it catches.

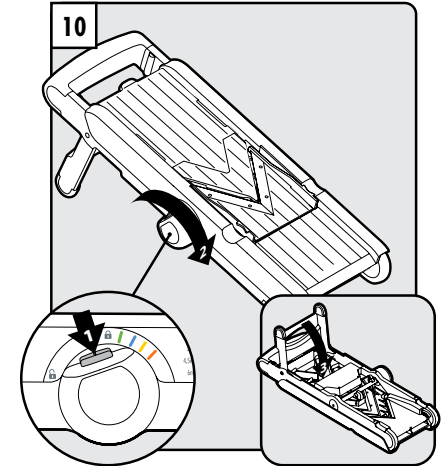

Press button on dial and turn to lock position. Fold in legs.

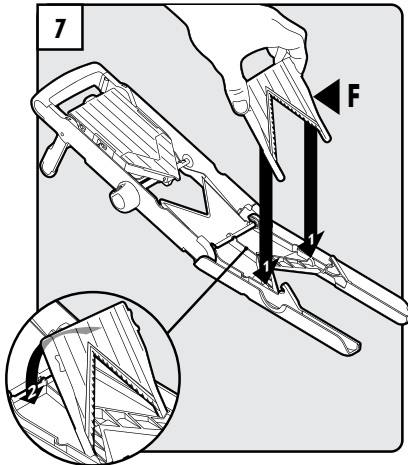

Place crinkle V-Blade (F) in storage by first sliding tips into sockets then pressing down V-Blade until it catches.

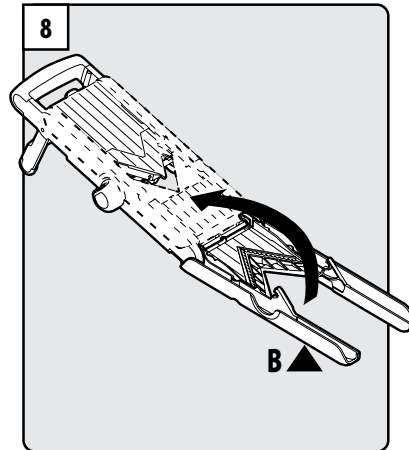

Close bottom runway (B).

ACCESSORIES

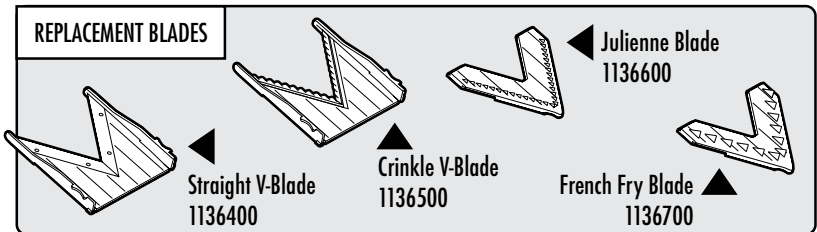

Available at oxo.com