

BODYRider

BRF700 BRF701 UPRIGHT FAN BIKE

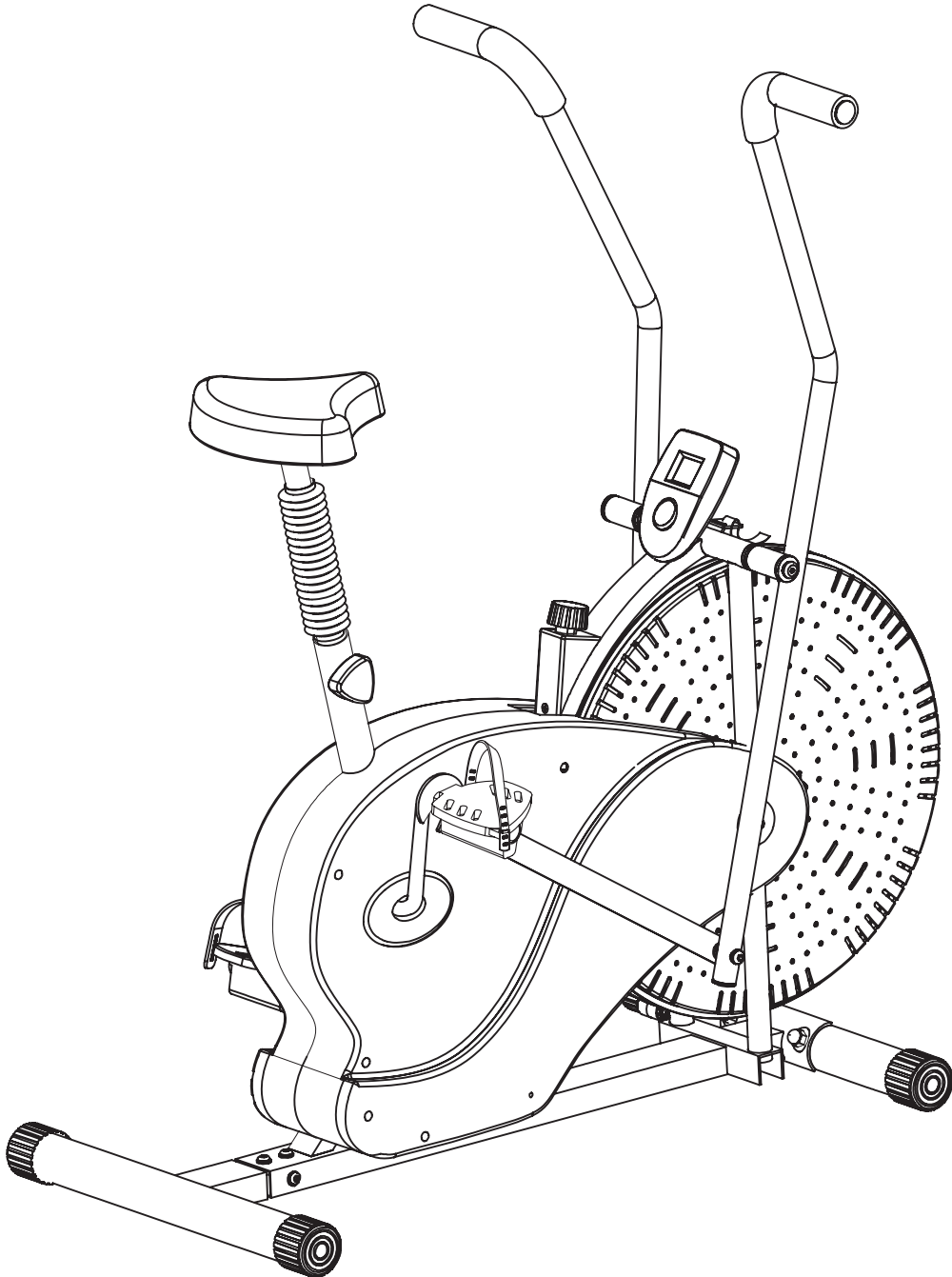

This product is intended for indoor, home use only and is not to be used in a commercial setting.

OWNER'S MANUAL

**PLEASE KEEP THESE INSTRUCTIONS FOR FUTURE USE & REFERENCE.
DO NOT DISCARD.**

WARNING: SERIOUS INJURIES AND EVEN DEATH CAN OCCUR IF THE PROPER SAFETY PRECAUTIONS ARE NOT FOLLOWED.

The diagram below highlights and reviews many of the important Safety and Warning labels also found on the unit. Please ensure any user of the unit familiarizes themselves with these Safety and Warning guidelines before use.

⚠ WARNING !

The use of this exercise equipment involves a **RISK OF PHYSICAL INJURY** as well as property damage, which can be minimized by observing the following guidelines:

1. **ALWAYS** wear comfortable clothing and shoes with good traction.
2. **ALWAYS** make sure all nuts and bolts are secured before use. **TIGHTEN PEDAL HINGE BOLTS EVERY 30 DAYS.**
3. **STOP EXERCISING** if you become dizzy, nauseous, have irregular heartbeats or breathing difficulties. Contact your physician immediately.
4. **ALWAYS** keep a large mat under the equipment to protect the floor or carpet.
5. **ALWAYS** use your equipment in a warm, dry, level, well-lit and ventilated indoor area.
6. **ALWAYS** keep body and clothing free and clear of moving parts.
7. **ALWAYS** keep your equipment clean and free of dust, moisture, debris and loose objects.
8. **NEVER** use the equipment if you are injured or have a physical condition that impairs your balance. **DO NOT** exercise under the influence of medication or alcohol.
9. **NEVER** allow small children or pets to approach the equipment. It is not a toy.
10. **NEVER** use the equipment if you exceed its weight limit of 250 lbs.
11. **NEVER** use the equipment if it does not function properly.

⚠ WARNING !

DO NOT REMOVE THE SEAT FOR ANY REASON

Exercising on this unit without the seat installed can result in **SERIOUS INJURY**. Ensure the seat is fully locked in place by tightening the knobs prior to use.

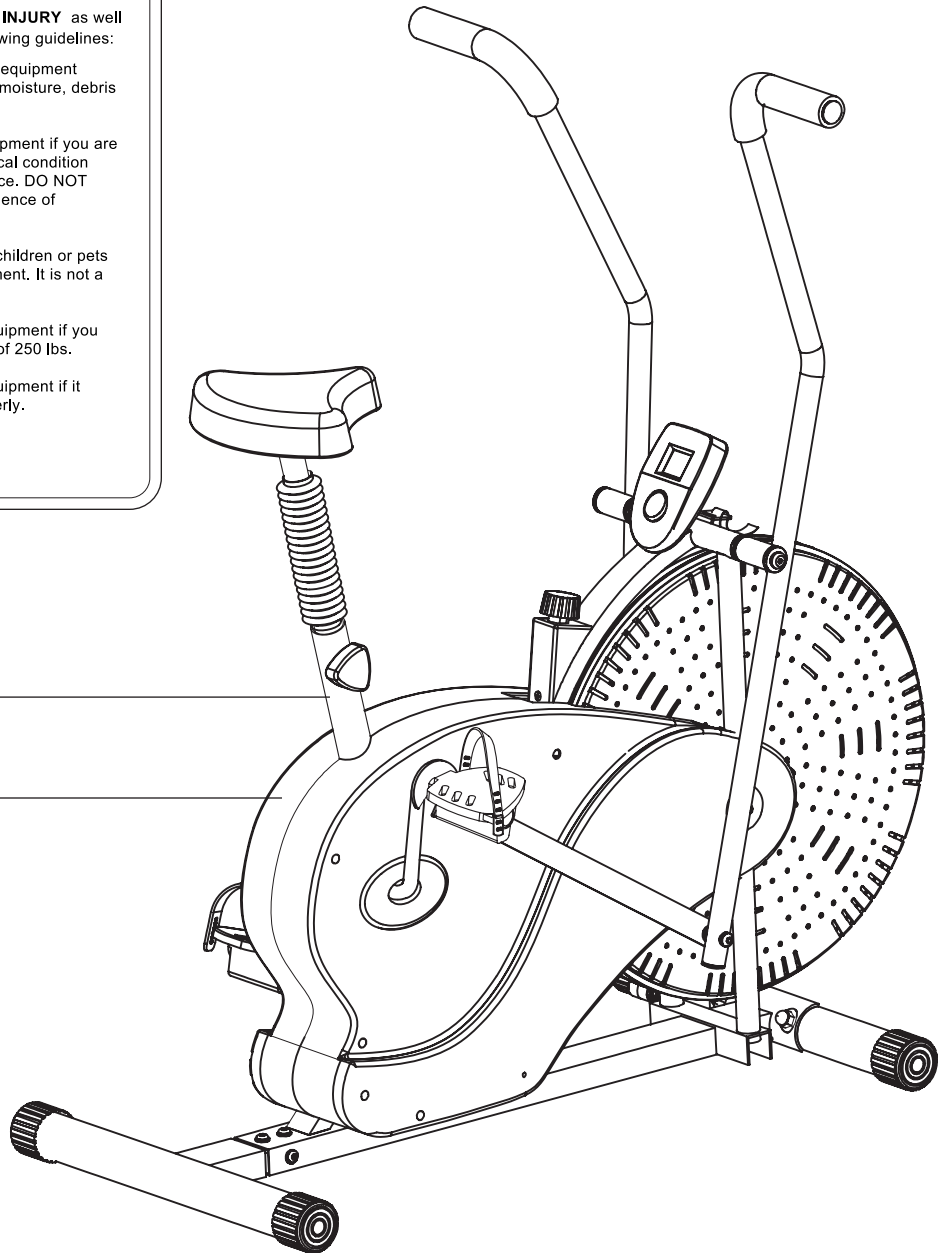

General Information

Safety

Before you undertake any exercise program, please be sure to consult with your doctor.

Frequent strenuous exercise should be approved by your doctor and proper use of your product is essential.

Excessive or incorrect training may result to health injuries.

Please read this manual carefully before commencing the assembly of your product or starting to exercise.

- Please keep all children away from this item when in use. Do not allow children to climb or play on this item when it is not in use.
- Supervise teenagers while they use this unit.
- For your own safety, always ensure that there is at least 3 feet of free space in all directions around your product while you are exercising.
- Regularly check to see that all nuts, bolts and fittings are securely tightened. Periodically check all moving parts for obvious signs of wear or damage.
- Any adjustment devices that could interfere with the user's movement on this unit should not be left projecting.
- Clean only with a damp cloth, do not use solvent cleaners. Lubricate the moving parts of your unit every 30 days with a silicone-based grease or product. If you are in any doubt, do not use your product; contact CUSTOMER SUPPORT.
- Before use, always ensure that your product is positioned on a solid, hard-flat surface.
- Do not place on carpet. If necessary, use a rubber mat underneath to reduce the possibility of slipping.
- Always wear appropriate clothing and footwear such as training shoes when exercising. Do not wear loose clothing that could become caught in moving parts during exercise.
- Do not use this unit if it is not functioning properly or if it is not fully assembled.
- Do not use this unit for commercial purposes. This unit is for home use only.
- Before use, you must read and understand all instructions & warnings stated in this Owner's Manual as well as posted on the equipment.
- It is the facility owner's responsibility to properly instruct users on the proper operation of the equipment and to warn them of the potential hazards.
- If at any time during exercise you feel faint, dizzy or experience pain, stop and consult your physician.

Assembling Tools

- Ruler with both Metric and English measurements
- 2 x Adjustable Wrenches
- 1 x Philips ("Crosshead") Screw Driver

Weight Limit

Your product is suitable for users weighing :
250 pounds or less

Storage and Use

Your product is intended for use in clean dry conditions. You should avoid storage in excessively cold or damp places as this may lead to corrosion and other related problems.

Warranty

Body Flex Sports warrants your product for a period of 1 year for the frame and 90 days on all parts if the item is used for the intended purpose, properly maintained and not used commercially.

Any alterations or incorrect assembly of the product will void this warranty.

Proof of purchase must be presented for any warranty validation (no exceptions). This warranty applies to the original purchaser only and is not transferable.

This warranty does not cover abuse or defects caused during use, storage or assembly. During the warranty period, Body Flex Sports reserves the right to:

1. provide replacement parts to the purchaser in an effort to repair the item.
2. repair the product returned to our warehouse (at the purchaser's cost).
3. replace the product if neither of the two previously mentioned actions effect repair. This warranty does not cover normal wear and tear on upholstery.

Questions

If you have any questions concerning the assembly of your item or if any parts are missing, please **DO NOT RETURN THE ITEM TO THE STORE OR CONTACT THE RETAILER.**

Our dedicated customer service staff can help you with any questions you may have regarding the assembly of this unit and can also mail you replacement parts.

Customer Support

Customer Support is open 9:00 a.m. to 5:00 p.m. (Pacific Time) Monday through Friday.

Please contact us by any of the following means :

Body Flex Sports, Inc.
21717 Ferrero Parkway, Walnut, CA 91789
Telephone: 1 (888) 266 - 6789
Fax: 1 (909) 598 - 6707
Email: info@bodyflexsports.com

Before Assembly

⚠ WARNING

1. Take a few minutes to familiarize yourself with the parts and hardware included with your product.
2. Assembly may require two people.
3. Check the frame for any damage and check any wiring (if present) for rips or tears. If you detect damage, rips, or tears, please contact our Customer Support Team before beginning any assembly.
4. Make sure all the hardware needed is included.
5. It is very important to follow the assembly instructions correctly and to make sure all parts are attached correctly and firmly tightened when the assembly process is complete.
6. Parts that are not tightened correctly will seem loose and can cause irritating noises and will cause damage to the equipment.

PLEASE NOTE : Many of the parts and hardwares listed on the parts list are already pre-assembled or installed on the unit.

Nylon Lock Safety Nuts

1. It is only necessary to tighten the bolts and nuts to “finger tight” during the assembly process. This will make it easier to complete certain steps by allowing more tolerance for all the parts to fit properly.
2. Do not tighten all the nuts onto the bolts securely until after you have completed assembly of your product.
3. Use wrenches, pliers, or ratchet and sockets to tighten the bolts and nuts.
4. The Nylon Nut should thread onto the Hex Bolt until the end of the Hex Bolt has passed through the Nylon insert inside the Nut. Please follow this guideline everytime you see this *Nylon Nut icon* throughout the assembly steps.

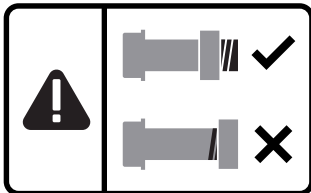

Tools Required For Assembly

Tool	Description/Purpose
Ruler (with both Metric and English measurements) QTY: 1	Use to measure the length or size of hardware including bolts to ensure you are using the correct part.
Adjustable or flat wrenches QTY: 2	Use to securely install parts including nuts and bolts.

Part Listing

The following parts list describes all of the parts illustrated on the exploded diagram on the following page.

PLEASE NOTE: most of these parts are already pre-assembled on your unit.

Description

1B Main Frame
2A Front Stabilizer
3 Rear Stabilizer
4LA Left Handlebar
4RA Right Handlebar
5E Seat Tube (enhanced)
6L Left Linkage
6R Right Linkage
7L Left Pedal
7R Right Pedal
8 Monitor
9 Seat
10 Washer (M8)
11 Nylon Nut (M8)
12A Bellows
13 Bolt (M10x18 mm)
14 Spring Washer (M10)
15 D Shape Washer (M10)
16 Handlebar Axle ($\Phi 15.8 \times 305$ mm)
17 Knob (M12x17 mm)
18 Bolt (M8x43 mm)
19 Washer (M8)
20 Nylon Nut (M8)
21 Big Washer (d17.5x $\Phi 34 \times 2$ mm)
22 Bushing ($\Phi 12.8 \times \Phi 21 \times 8$ mm)
23L Left Nylon Nut w/Black inner nylon ring (M10)
23R Right Nylon Nut w/White inner nylon ring (M10)
24 Bolt (M8x16 mm)
25 Spring Washer (M8)
26 Carriage Bolt (M10x57 mm)
27 Arc Washer (M10)
28 Cap Nut (M10)
29 Special Washer ($\Phi 16 \times \Phi 28 \times 0.3$ mm)
30 Round Cap (50)
34 Bushing ($\Phi 8.3 \times \Phi 18 \times 5$ mm)
35 Bearing (TY-6201)
36 Tension Control

Description

37A Monitor Wire (Lower)
37B Monitor Wire (/Upper)
38 Friction Belt (L1030x1200xB18xH1.5 mm)
39 Bushing ($\Phi 28 \times 4 \times \Phi 24$ mm)
40 Foam Grip ($\Phi 23 \times \Phi 33 \times 275$ mm)
41 Round Cap (25 mm)
42 Screw (ST4.8x18 mm)
43L Left Chain Cover
43R Right Chain Cover
44 Screw (ST4.8x19 mm)
45 Screw (ST4.8x45 mm)
46 Screw (ST4.8x30 mm)
47 Screw (ST4.8x16mm)
48 Left Nut for Crankshaft
49 Washer for Crankshaft
50 Left Crankshaft Bearing Collar
51 Crankshaft Bearing Set
52 Bearing Brace
53 Right Crankshaft Bearing Collar
54 Washer (d20x40x3 mm)
55 Chain wheel with Crankshaft
56 Chain (1/4"x1/8")
58 Spring ($\Phi 1.8 \times \Phi 10 \times 32 \times N9$ mm)
59 Nut (M10x1xH9.5xS15 mm)
60 Adjustable Bolt (M6x36x $\Phi 10 \times 5$ mm)
61 Nut (M6xH5xS10 mm)
62 U Bracket(30x10x1.5 mm)
63 Nut (M10x1xH5xS17 mm)
64 Fan Wheel Axle ($\Phi 10 \times 150 \times M10 \times 1.0 \times 39 \times 26$ mm)
65 Bushing
66 Fan Wheel ($\Phi 503 \times 85$ mm)
67 Gear Shaft
68 Nut (M10x1xH5xS17 mm)
69 Sensor
70 Washer (d10x $\Phi 20 \times 2$ mm)
71 Crank Cover (85x64x4 mm)

Exploded View

The following diagram is provided to help you familiarize yourself with the parts and hardware that will be used during the assembly process.

PLEASE NOTE : Not all of the parts and hardware you see here will be used while you are assembling the machine because some of these items are already pre-installed. Please use this page only as a reference guide for parts and hardware.

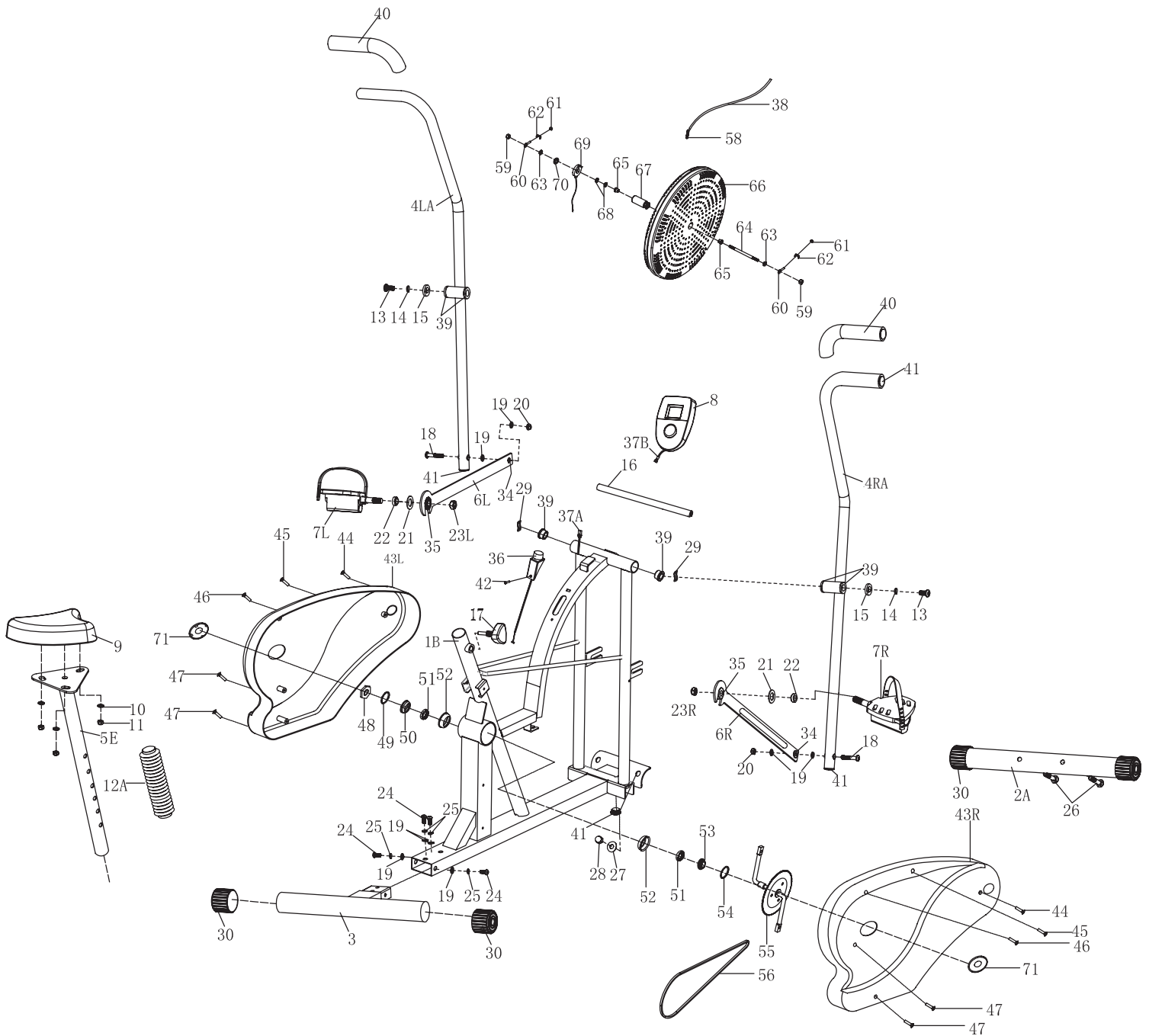

Hardware and Tool List

The following hardware is used to assemble your unit. Please take a moment to familiarize yourself with these items.

PLEASE NOTE: Most of these parts are already *pre-assembled* on your unit. Do not be alarmed if you see parts on this page that are not included in your hardware packet.

Bolts



#13 Bolt (M10x18 mm)
[2 pieces]
Pre-assembled

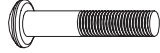

#18 Bolt (M8x43 mm)
[2 pieces]



#24 Bolt (M8x16 mm)
[4 pieces]

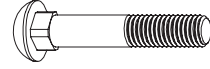

#26 Carriage Bolt (M10x57 mm)
[2 pieces]

Washers

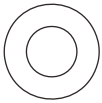

#10 Washer (M8)
[3 pieces]
Pre-assembled



#14 Spring Washer (M10)
[2 pieces]
Pre-assembled

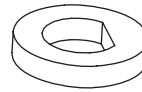

#15 D Shape Washer (M10)
[2 pieces]
Pre-assembled

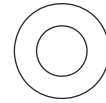

#19 Washer (M8)
[8 pieces]

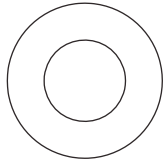

#21 Big Washer
[2 pieces]



#25 Spring Washer (M8)
[4 pieces]



#27 Arc Washer (M10)
[2 pieces]



#29 Special Washer
[2 pieces]
Pre-assembled

Nuts



#11 Nylon Nut (M8)
[3 pieces]
Pre-assembled



#20 Nylon Nut (M8)
[2 pieces]



#23L Left Nylon Nut
w/ BLACK inner nylon ring
[1 piece]



#23R Right Nylon Nut
w/ WHITE inner nylon ring
[1 piece]



#28 Cap Nut (M10)
[2 pieces]

Others

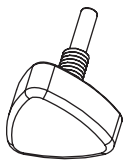

#17 Knob (M12)
[1 piece]



#22 Bushing
[2 pieces]

Tools (Included)

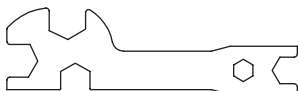

S10-S13-S15-S17-S19
[1 piece]



6mm Allen Wrench
[2 pieces]

Assembly STEP 1

FRONT STABILIZER ASSEMBLY

Secure the Front Stabilizer (#2A) to the Main Frame (#1B) with two Carriage Bolts (#26), two Arc Washers (#27) and two Cap Nuts (#28).

Hardware Required

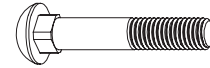

#26 Carriage Bolt (M10x57 mm)
[2 pieces]



#27 Arc Washer (M10)
[2 pieces]



#28 Cap Nut
[2 pieces]

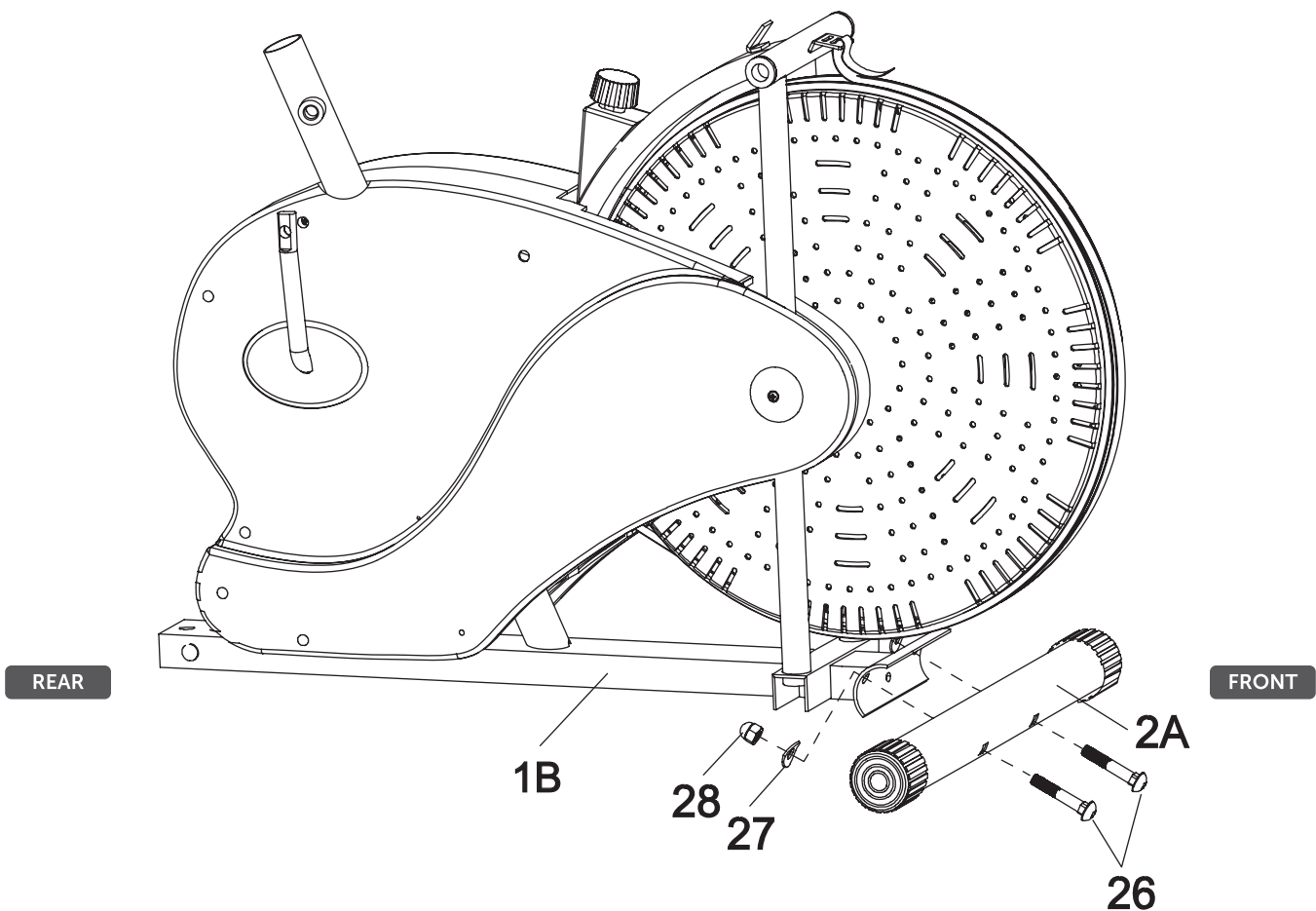

Assembly STEP 2

REAR STABILIZER ASSEMBLY

Secure the Rear Stabilizer (#3) to the Main Frame (#1B) with four Bolts (#24), four Spring Washers (#25) and four Washers (#19).

Hardware Required

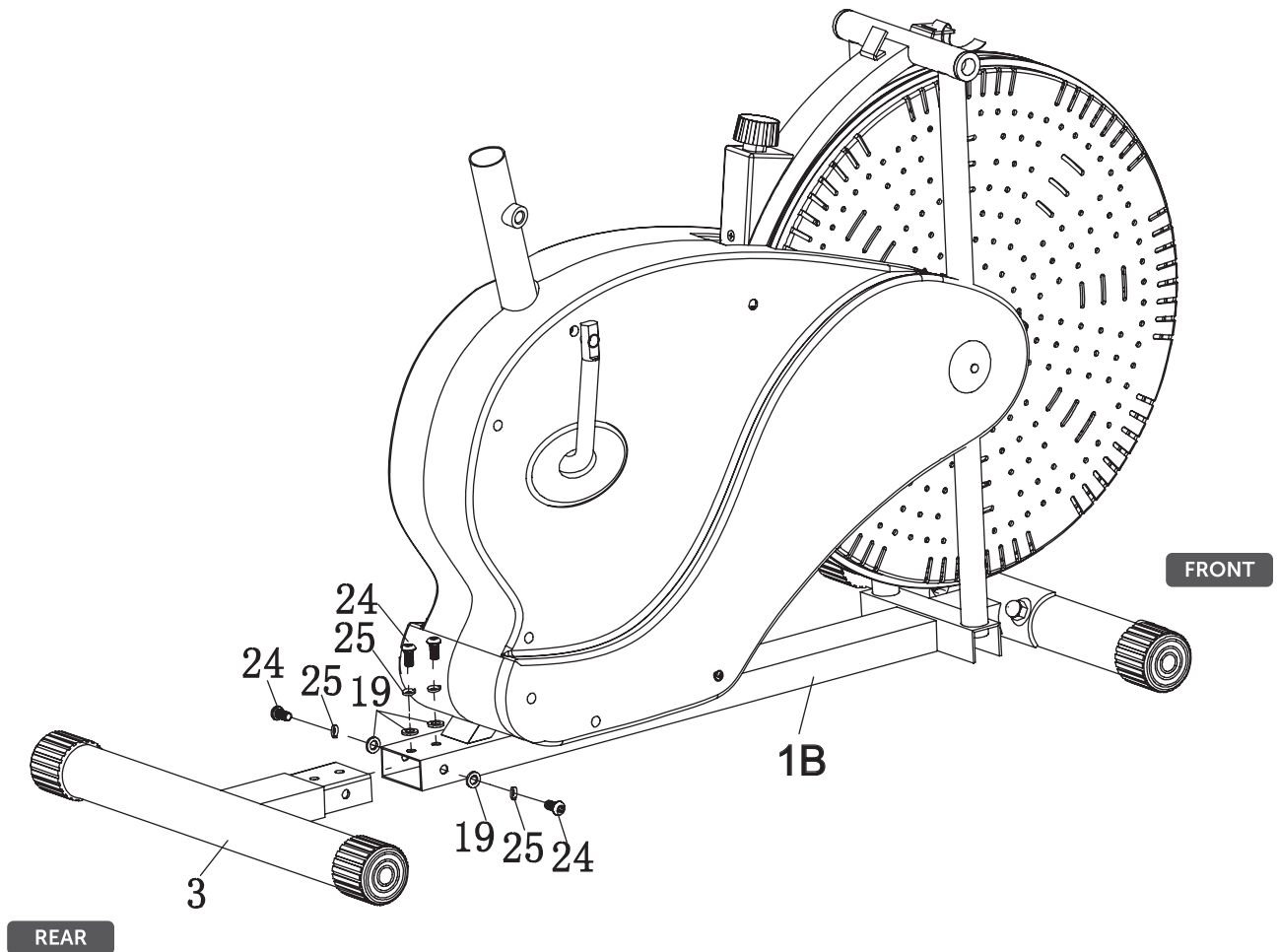
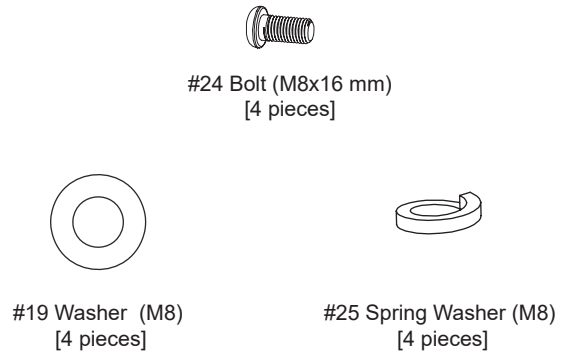





Assembly STEP 3A

Attach the Right Pedal (#7R) to the Right Linkage (#6R) using a Bushing (#22) and a Big Washer (#21) in between. Then screw the Right Pedal (#7R) tightly into the right crank and then secure it with the Right Nylon Nut (#23R)*. Repeat this process on the left side**.

Please Note :

- Left Hand Side: Turn **COUNTERCLOCKWISE** to tighten the Left Pedal (#7L) on the left crank. Then turn **CLOCKWISE** to tighten the Left Nylon Nut (#23L) [BLACK inner nylon ring] to secure the left pedal assembly.
- Right Hand Side: Turn **CLOCKWISE** to tighten the Right Pedal (#7R) on the right crank. Then turn **COUNTER-CLOCKWISE** to tighten the Right Nylon Nut (#23R) [WHITE inner nylon ring] to secure the right pedal assembly.

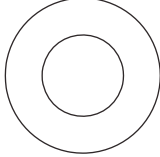
Hardware Required

	
#23L Left Nylon Nut w/ BLACK inner nylon ring [1 piece]	#23R Right Nylon Nut w/ WHITE inner nylon ring [1 piece]
	
#21 Big Washer [2 pieces]	#22 Bushing [2 pieces]

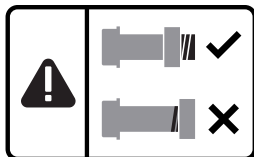
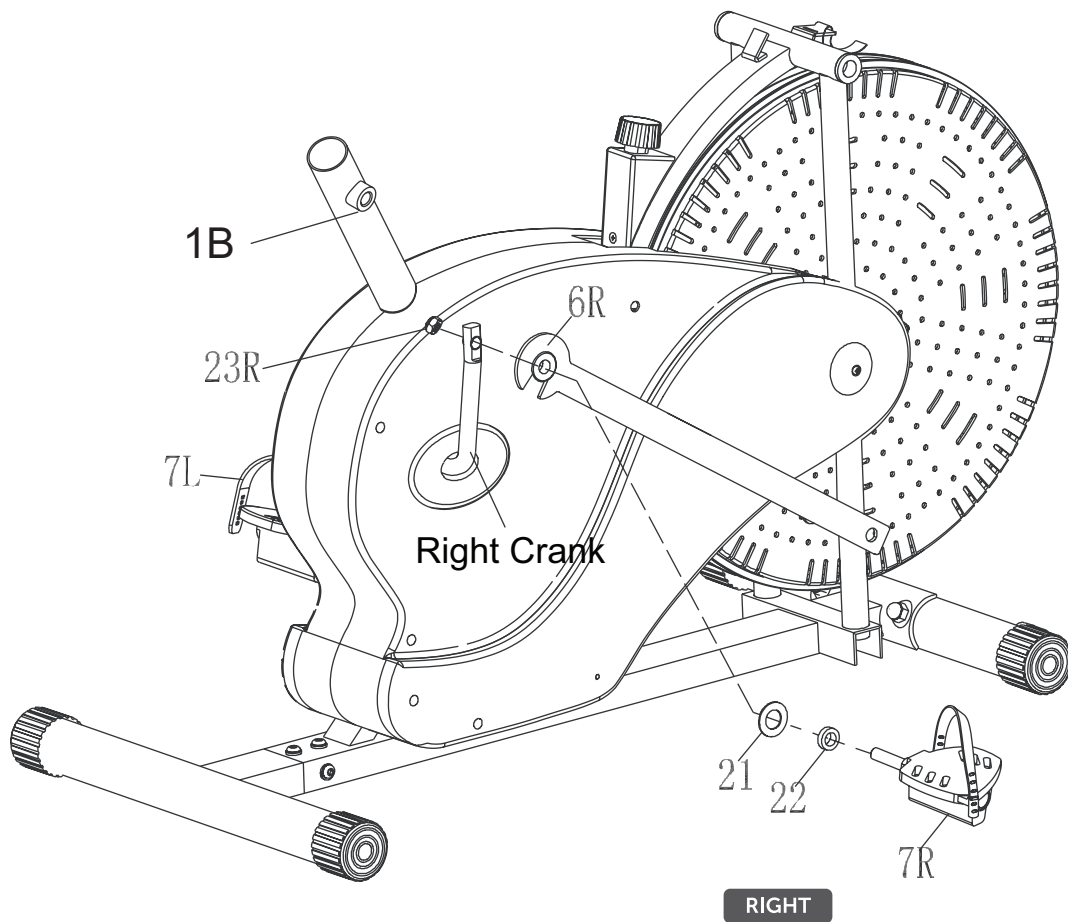

Assembly STEP 3B

**LEFT Side:

FOR PROPER ASSEMBLY, please ensure that the Left Linkage (#6L) is assembled to the outer edge (away from shroud) of the Left Crank.

The order of parts (from inner side to outer) should look like the exploded diagram below in the following sequence: **Left Nylon Nut (#23L) > Left Crank > Left Linkage (#6L) > Big Washer(#21) > Bushing (#22) > Left Pedal (#7L)**

**RIGHT Side:

FOR PROPER ASSEMBLY, please ensure that the Right Linkage (#6R) is assembled to the outer edge (away from shroud) of the Right Crank.

The order of parts (from inner side to outer) should look like the exploded diagram below in the following sequence: **Right Nylon Nut (#23R) > Right Crank > Right Linkage (#6R) > Big Washer(#21) > Bushing (#22) > Right Pedal (#7R)**

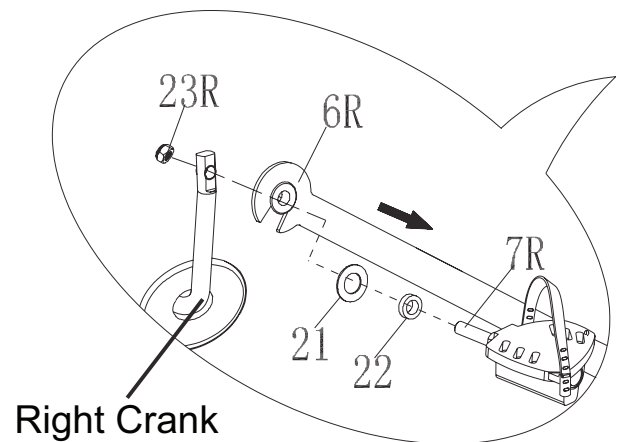
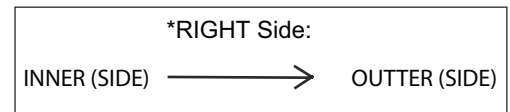
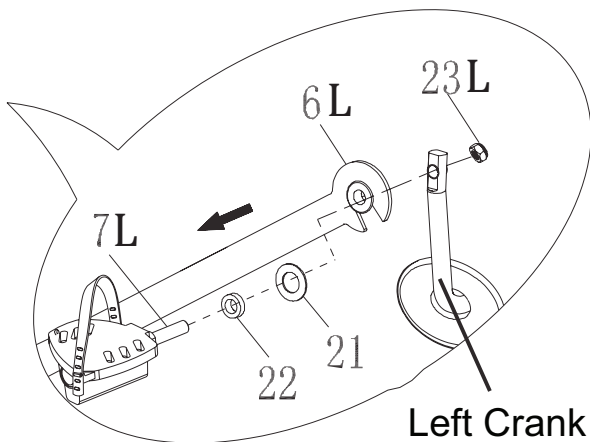
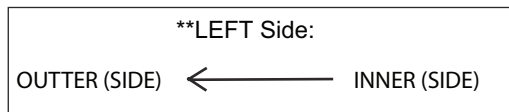

Please Note :

LEFT SIDE: Please ensure that the notched side of Bushing (#22) is facing Big Washer (#21) from the left side so that Bushing (#22) can be inserted into Big Washer (#21) and the two pieces fit flushed together. Please refer to the exploded diagram for correct orientation and positioning.

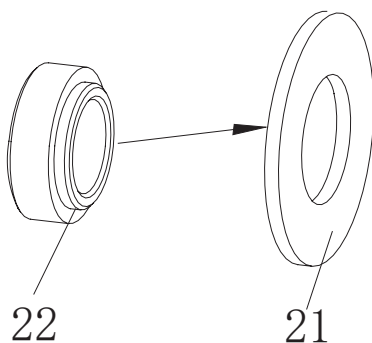

Please Note :

RIGHT SIDE: Please ensure that the notched side of Bushing (#22) is facing Big Washer (#21) from the right side so that Bushing (#22) can be inserted into Big Washer (#21) and the two pieces fit flushed together. Please refer to the exploded diagram for correct orientation and positioning.

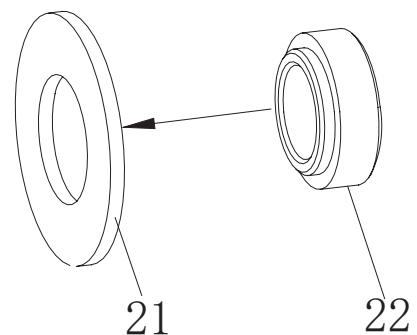

Assembly STEP 4A

Remove the two Special Washers (#29), two D Shape Washers (#15), two Spring Washers (#14), and two Bolts (#13) that are pre-assembled on the Handlebar Axle (#16). Set them aside close by as they will be used in this step.

Insert the Handlebar Axle (#16) through the Main Frame (#1B), making sure the Handlebar Axle (#16) is centered. If you encounter too much friction, try using WD40 or Vaseline as a lubricant.

Next, on the right side, slide one Special Washer (#29) on Handlebar Axle (#16) followed by Right Handlebar (#4RA) and secure with one D Shape Washer (#15)** [please see close-up diagram/note below], one Spring Washer (#14), and one Bolt (#13). Repeat this process on the left side using Left Handlebar (#4LA).

Carefully cut off the zip tie on the bushing of the Right Linkage (#6R). With the help of an assistant, on the right side as shown in drawing below, insert one Bolt (#18) through the Right Handlebar (#4RA) followed by one Washer (#19) and then the Bushing (#34) of Right Linkage (#6R).

Secure these together from the other "inner" side of Right Linkage (#6R) using one other Washer (#19) and one Nylon Nut (#20). Repeat this process on the left side with the Left Handlebar (#4LA).

Hardware Required

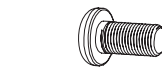

#13 Bolt (M10x18 mm)
[2 pieces]

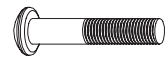

#18 Bolt (M8x43 mm)
[2 pieces]



#20 Nylon Nut (M8)
[2 pieces]



#14 Spring Washer (M10)
[2 pieces]



#15 D Shape Washer (M10)
[2 pieces]



#19 Washer (M8)
[4 pieces]



#29 Special Washer
[2 pieces]

[***When assembling D Shape Washer (#15), please ensure the flat edge matches and is flush with the corresponding flat edge of Handlebar Axle (#16) as marked in close-up diagram below.]

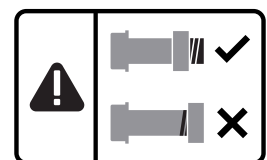
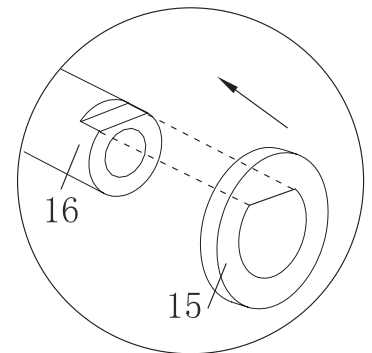
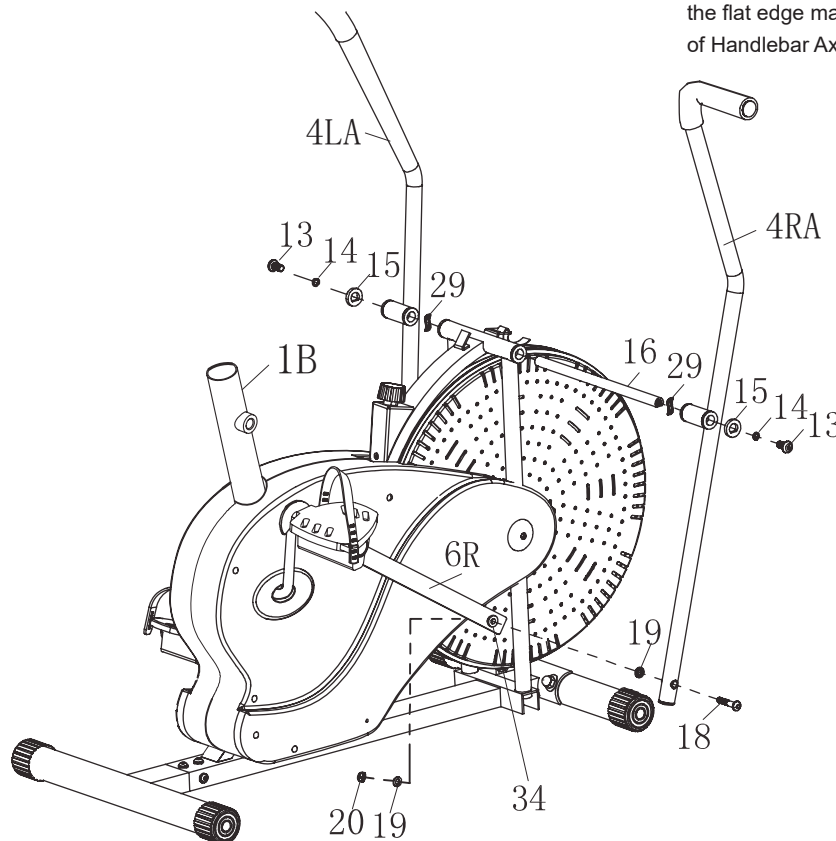

Assembly STEP 4B

**LEFT Side:

Please ensure that the Left Handlebar (#4L) is assembled to the outer edge (away from shroud) of the Left Linkage (#6L).

The order of parts (from inner side to outer) should look like the exploded diagram below in the following sequence:
Nylon Nut (#20) > Washer (#19) > Bushing (#34) of Left Linkage (#6L) > Washer (#19) > Left Handlebar (#4L) > Bolt (#18)

*RIGHT Side:

Please ensure that the Right Handlebar (#4R) is assembled to the outer edge (away from shroud) of the Right Linkage (#6R).

The order of parts (from inner side to outer) should look like the exploded diagram below in the following sequence:
Nylon Nut (#20) > Washer (#19) > Bushing (#34) of Right Linkage (#6R) > Washer (#19) > Right Handlebar (#4R) > Bolt (#18)

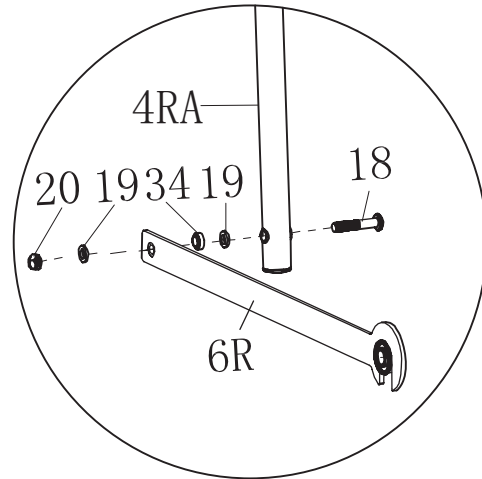
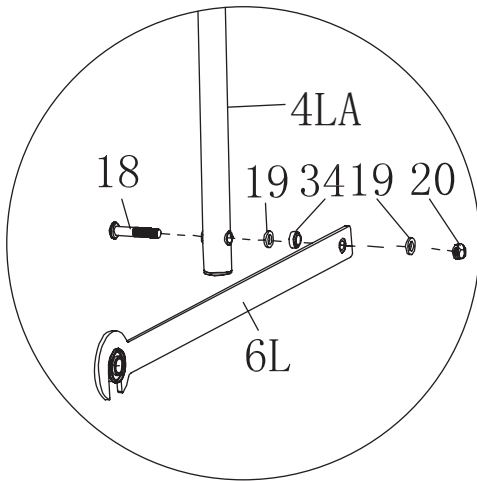
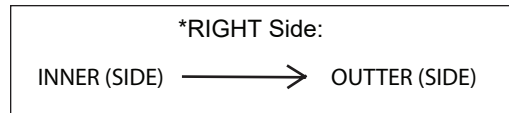
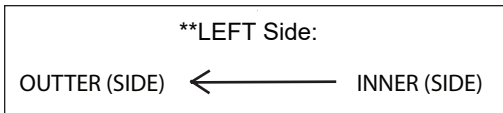

Assembly STEP 5

Remove the three Washers (#10) and three Nuts (#11) that are pre-assembled on the Seat (#9). Then, attach the Seat (#9) to the Seat Tube (enhanced) (#5E) and secure it with three Washers (#10) and three Nuts (#11) that were previously removed.

Attach Bellows (#12A) to the Seat Tube (enhanced) (#5E) as shown in illustration below.

Insert the Seat Tube (enhanced) (#5E) into the opening of the post that is protruding from the Main Frame (#1B) a minimum of 4 inches to engage the lowest hole. Please ensure that the hole on the Seat Tube (enhanced) (#5E) is facing the same side as the hole located on the Main Frame (#1B) and insert the Knob (#17) through the Main Frame (#1B) post and through the hole on the Seat Tube (enhanced) (#5E). Please refer to the illustration below.

Always ensure that the Knob (#17) is securely tightened and engaged through the hole on the Main Frame (#1B) and the hole setting most comfortable to you on the Seat Tube (enhanced) (#5E) for your safety.

Hardware Required

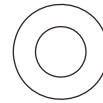

#10 Washer (M8)
[3 pieces]



#11 Nylon Nut (M8)
[3 pieces]

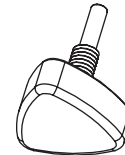

#17 Knob (M12)
[1 piece]

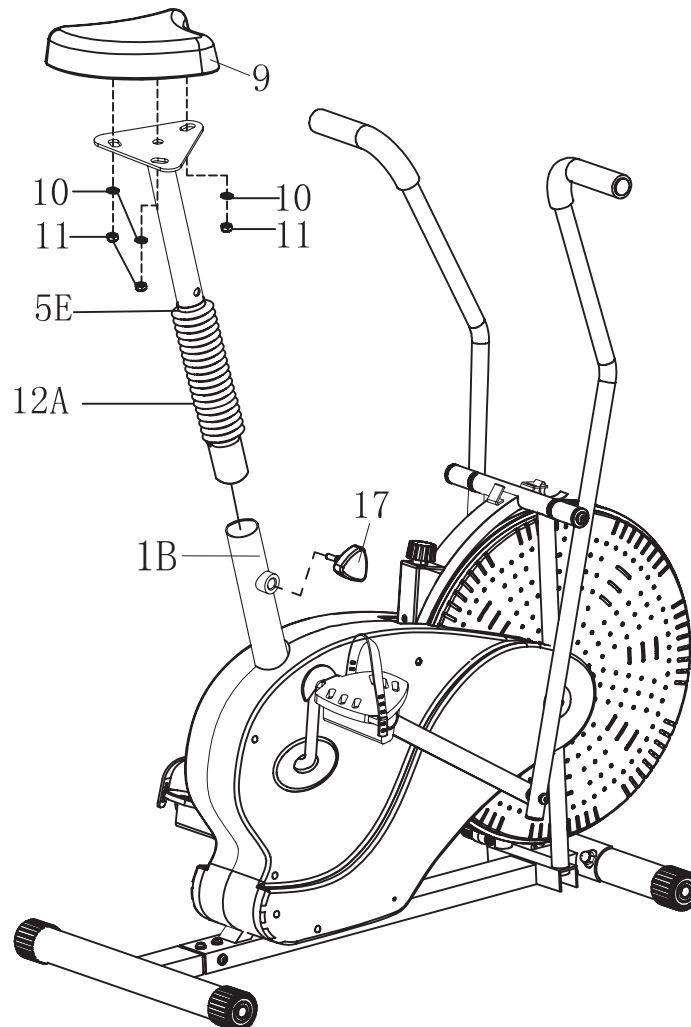

Assembly STEP 6

Attach the Monitor (#8) to the Main Frame (#1B) and then connect the Monitor Wire (#37A) to the Monitor Wire (#37B).

Hardware Required

No Hardware Required

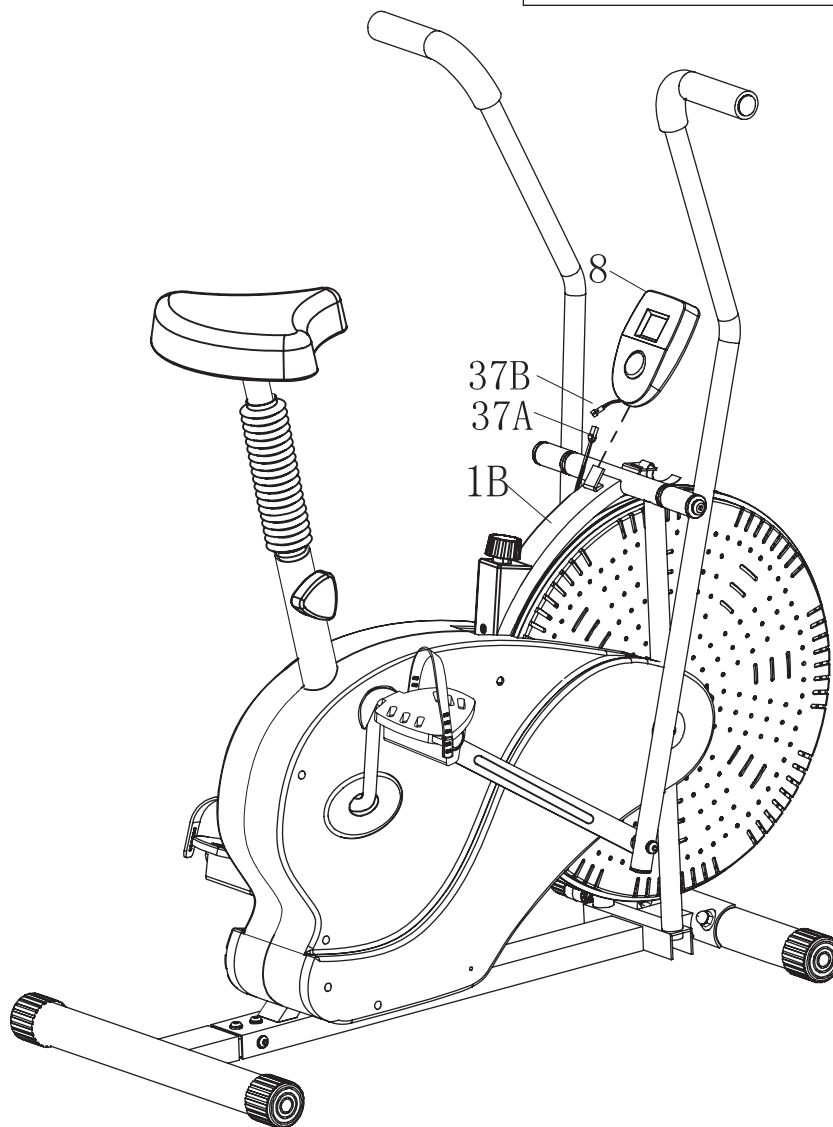

THE ASSEMBLY PROCESS IS NOW COMPLETE.

However, for your own safety, please make sure to read this entire Owner's Manual which includes safety instructions and warnings, as well as any safety/warning labels affixed to the product before use. For your safety, please visually and functionally inspect and test the unit after assembly is complete.

Tension Adjustment

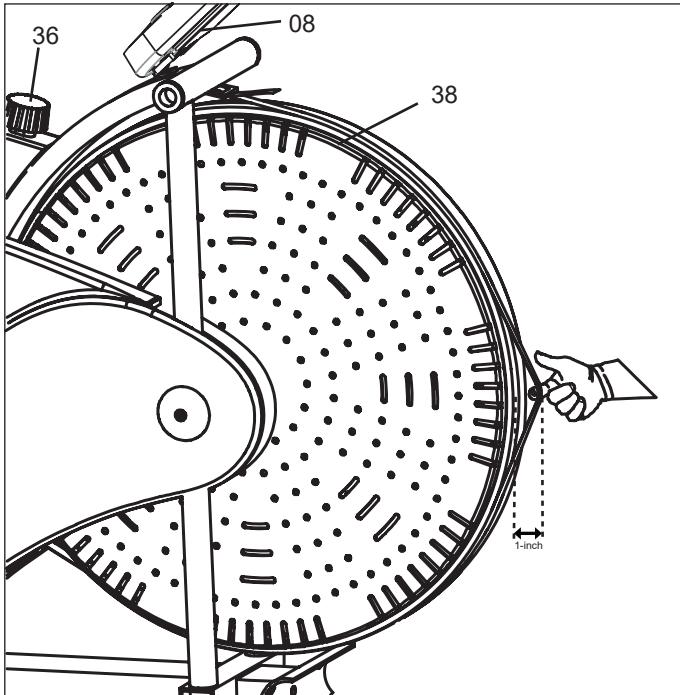

1-inch Distance

(use this measurement as a “test” when you gently tug on Friction Belt (#38) away from flywheel)

NOTE:

In order to clearly show parts used in Tension Adjustment process, this drawing has been modified and does not show all parts nor full assembly.

WARNING:

If the Friction Belt (#38) is tightened to an extremely tight/taut setting against the flywheel, you may risk damaging, over-wearing, over-stressing and/or breaking the Friction Belt (#38).

Please see below for more details to prevent damage and breakage.

1. FOR TENSION ADJUSTMENT:

Simply turn the Tension Control (#36).

- To increase tension (+ higher resistance and more difficult), turn clockwise.
- To decrease tension (- lower resistance and less difficult), turn counter-clockwise.

***WARNING: Please turn the Tension Control (#36) gently. **DO NOT** use excess force to avoid damaging any parts of your unit.

2. FOR CALIBRATING TENSION ADJUSTMENT SYSTEM:

- Gently turn Tension Control (#36) counter-clockwise and keep turning until the knob can no longer turn (i.e. decrease the tension fully).
- Adjust the Friction Belt (#38) so that when you gently tug it out away from flywheel, there is a 1" distance of slack between the Friction Belt (#38) and the flywheel as shown in diagram.

***WARNING: It is important you check for this minimum of 1-inch distance to avoid damaging, over-wearing, over-stressing and/or breaking the Friction Belt (#38).

NOTE:

It is normal for the Friction Belt (#38) to periodically loosen due to regular use. Repeat the below process anytime you feel it may be necessary to recalibrate the tension adjustment system.

Computer Operation



Key Function

MODE :

Press to select the display function of your choice.

The unit can be reset by changing battery or pressing the **MODE** key for 3 seconds.

Operation Procedures

FUNCTION

- TIME** : Displays the total amount of time using the machine.
SPEED : Displays current speed.
DISTANCE : Displays the distance traveled.
CALORIES : Displays the amount of calories burned.
ODOMETER : Displays total accumulated distance. ODO will reset when MODE is pressed for 3 seconds or when batteries are changed.
SCAN : The monitor will then rotate displaying through the following functions: time,speed,distance, calories and odometer. Each function will display for 4 seconds.

NOTE:

1. If the display is faint or shows no figures ,please replace the batteries.
2. The monitor will automatically shut off if there is no signal received after 4 minutes .
3. The monitor will auto-power on when exercise and/or motion input is detected.
4. The monitor will automatically start calculating when you start to exercise and will stop calculating when you stop exercising for 4 seconds .

Specifications

FUNCTIONS	AUTO SCAN	Every 4 seconds
	TIME	00:00-99:59 min
	SPEED	0.0-99 mi/h
	CALORIES	0.0-999.9 KCal
	DISTANCE	0.0-999.9 mi.
	BATTERY TYPE	2 pcs of AA
	OPERATING TEMP	32°F - 104°F
	STORAGE TEMP	32°F - 160°F

***IMPORTANT NOTE :**

Please remember that the functions in this computer are only meant to be tools to monitor your workout progress; they are not meant to provide medical information or be used for medical purposes. Please consult a physician before beginning any workout program.

Computer Operation

NOTES (Regarding the Computer Monitor):

Warning: This device complies with Part 15 of the FCC Rules. Operation is subject to the following two conditions:

- (1) This device may not cause harmful interference.
- (2) This device must accept any interference received, including interference that may cause undesired operation.

Caution:

This equipment has been tested and found to comply with the limits for a Class B digital device, pursuant to part 15 of the FCC Rules. These limits are designed to provide reasonable protection against harmful interference in a residential installation. This equipment generates, uses and can radiate radio frequency energy and, if not installed and used in accordance with the instructions, may cause harmful interference to radio communications. However, there is no guarantee that interference will not occur in a particular installation. If this equipment does cause harmful interference to radio or television reception, which can be determined by turning the equipment off and on, the user is encouraged to try to correct the interference by one or more of the following measures:

- Reorient or relocate the receiving antenna.
- Increase the separation between the equipment and receiver.
- Connect the equipment into an outlet on a circuit different from that to which the receiver is connected.
- Consult the dealer or an experienced radio/TV technician for help.

Safety and Maintenance

Safety & Warning

- Make sure all nuts, bolts, and screws are tightened prior to use.
- Be sure that all adjustment locking devices and safety devices are properly engaged prior to use!
- Never over-tighten the above-mentioned devices and parts to avoid damage to the unit.
- Check for loose parts and components and make proper adjustments prior to use.
- Check to see if there are any tears or bends in the welding or metal prior to use. If tears or bends are found, DO NOT use the unit and contact our CUSTOMER SUPPORT.
- Extreme care must be taken to not allow your feet, fingers, hair, clothing, and/or any loose items to be snagged into any portion of the bike when the unit is in motion. Failure to follow these instructions could result in serious injury, including the loss of fingers.
- Always wait for the pedals and other moving parts (which can gain great momentum during riding) to come to a complete stop before dismounting the unit to avoid serious injury.

How To (Emergency) Stop

NOTE : Always wait for the pedals and/or any other moving parts (which can gain great momentum during riding) to come to a complete stop before dismounting the unit to avoid serious injury.

- To reduce speed on the bike, you may use the combinations of your feet on the Left/Right Pedals (**#7L/R**) and your hands on the Left/Right Handlebars (**#4LA/#4RA**) to gently and safely apply counter-momentum.
- Wait for the pedals to come to a complete stop.
- Now you may safely dismount the unit

How To Move/Transport The Bike For Storage

NOTE :

To safely move, transport, and/or store the unit, please seek the help of capable assistants (minimum of 2 people).

- Position one person on each side of the bike (one on the left, and one on the right).
- Have each person use the hand closest to the Seat (**#9**) to grip it. Then, grip the other hand from underneath the respective Handlebar (**#4LA or #4RA**). (These are the safest areas to avoid injury during this process.)
- Have both people simultaneously lift the unit to move/transport the unit to the desired area.

How To Adjust The Seat

- Using one hand to hold Seat Tube (enhanced) (**#5E**), unscrew Knob (**#17**) using the other hand.
- Slide and adjust Seat Tube (enhanced) (**#5E**) to the desired hole setting to your preferred height.
- Holding Seat Tube (enhanced) (**#5E**) at this setting, re-insert/re-screw Knob (**#17**), ensuring it engages and fully inserts through the holes of Main Frame (**#1B**) and Seat Tube (enhanced) (**#5E**). Please make sure to securely tighten Seat Tube (enhanced) (**#5E**) but not over-tighten.
- Before sitting on the cycle, press down firmly and pull up slightly on the seat to make sure it is engaged and secure.

Maintenance & Care

- Please review all safety instructions and warnings in this entire Owner's Manual, as well as any safety/warning labels affixed to the product before use.
- Do not use solvent cleaners. If you are in any doubt, do not use your cleansing product; contact CUSTOMER SUPPORT.
- The specific parts on your unit which may see possible signs of wear after prolonged use are listed as follows (please check these parts before each use):
Tension Control (**#36**); Left/Right Pedals (**#7L/#7R**); Left/Right Handlebars (**#4LA/#4RA**).
- For any replacement warning labels, please contact our CUSTOMER SUPPORT at

1 (888) 266-6789 or 1 (909) 598-9876, or mail in a written request to:

Body Flex Sports Inc.
21717 Ferrero Parkway
Walnut, CA 91789

More detailed information about how to reach our CUSTOMER SUPPORT may be found on Page 2 of the Owner's Manual under the "CUSTOMER SUPPORT" section.

Troubleshooting

(AFTER COMPLETE ASSEMBLY)

Troubleshoot Area	Solution
Calories/Distance/ Time (Etc.)	<p>If the computer is <u>not displaying the CALORIES/DISTANCE/TIME/(ETC.) functions</u> (or you are getting inaccurate readings), please adjust the following:</p> <ol style="list-style-type: none">1. Check to ensure all computer sensor wires are properly connected and are not damaged.2. You may need to refer to installation/assembly directions for the sensor wires in this manual.
Computer Display	<p>If the <u>computer display is blank & not displaying any data</u> (or does not appear to power on), please adjust the following:</p> <ol style="list-style-type: none">1. Check to ensure all sensor wires are all properly connected and are not damaged.2. Check to ensure the AC Adapter* or Batteries* are properly plugged in or fully charged.3. Check your product manual to determine if your model uses either AC Adapter or batteries to power your unit.

Warm-Up Instructions

Before use, you must read and understand all instructions & warnings stated in this Owner's Manual as well as posted on the equipment. Before beginning any exercise program including the following flexibility exercises, please consult with your physician.

The following flexibility exercises are provided to you as a means to prevent injury while you are exercising. A proper warm-up routine decreases the chance of injuring your muscles while you are exercising. Please take the time to do these flexibility exercises before and after each time you exercise.



Groin Stretch

1. Sit with your knees flexed and soles of feet together.
2. Hold your ankles and bend at your hips (keep your back straight) as you press your knees toward the floor with your elbows.

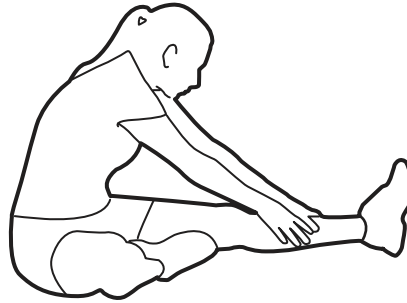

Hamstring Stretch

1. Sit with your left leg extended and bend your right leg at the knee as you place the sole of your right foot against the inner thigh of your extended leg.
2. Flex the foot of your extended leg (toes pointed toward ceiling) and gently bend forward from your hips; keep your back straight.
3. Reach your hands on your extended leg as far as possible and then switch legs and repeat.

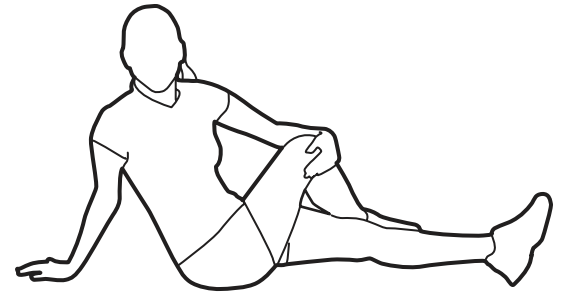

Trunk Twister

1. Sit with your leg extended and bend your right knee as you cross your right leg over your left leg. Your right foot of your extended leg foot should be flat on the floor alongside your left knee.
2. Place your left arm on the outside of your right leg and pull against that leg while twisting your trunk as far as possible to the right. Place your right hand on the floor behind your buttocks. Reverse leg positions and repeat.

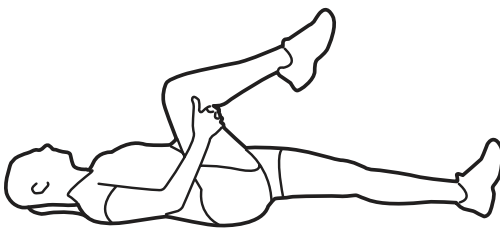

Groin Stretch

1. Lie on your back and raise your right leg as you clasp both hands under the back of the knee. Keep your left leg straight.
2. Gently pull your right leg toward your trunk without raising your upper body. Switch leg positions and repeat.

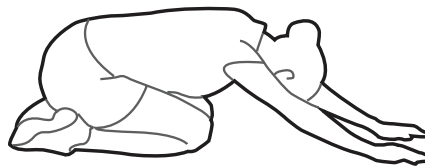

Trunk Flexion, Prone

1. Assume the depicted position on your hands and knees. Stretch your hands out in front of you and then slowly start to pull them back in toward your body as you tuck your chin and arch your back upward.
2. Return to the starting position slowly.

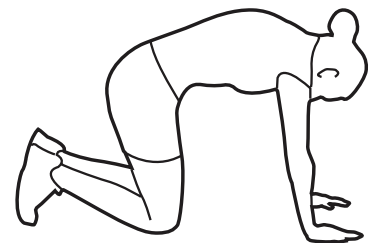

Warm-Up Instructions



Shoulder Stretch

1. Bring your right hand over your right shoulder to the upper back and bring your left hand under your left shoulder to the upper back.
2. Try to reach your fingertips. If you are not able to reach your fingertips, use a towel as an extension of your hands and gently pull one hand toward the other.
Reverse arm positions and

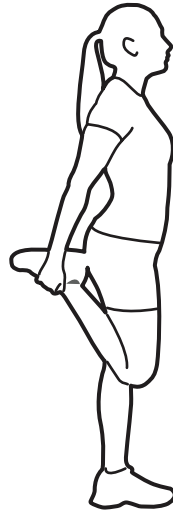

Quadriceps Stretch

1. Stand on your left leg and hold onto a support with your left hand.
2. Flex your right leg behind you, grasp your ankle or foot with your right hand and pull your foot toward your buttocks. Keep your back straight and right knee pointed down.
Repeat on the other leg.

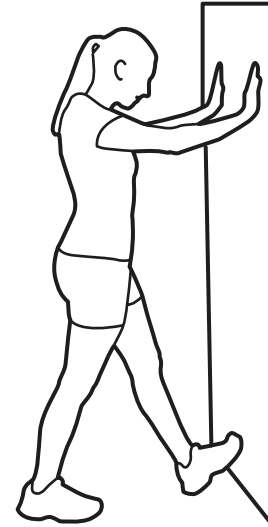

Calf Twister

1. Place both hands against a wall to aid your balance. Press the ball of your left foot against the wall and keep the heel of the same foot rested on the floor (make sure your left knee is bent).
2. Slowly start to straighten your left knee and you will feel the muscles in your left calf stretch.
Switch leg positions and repeat.

This page is left blank intentionally

THANK YOU FOR YOUR PURCHASE
MODEL NO.: BRF700 / BRF701

Please fill in the information below and keep this manual along with your sales receipt as proof of purchase.

Serial Number :

Date of Purchase :

Retailer :

Body Flex Sports Inc.
21717 Ferrero Parkway
Walnut, CA 91789

Phone: 1 (888) 266-6789
Fax : 1 (909) 598-6707
Email : info@bodyflexsports.com