

Tank RV Water Heater Chauffe-eau De Réservoir VR

Installation and Operation Manual Manuel d'installation et d'utilisation



WARNING

If the information in these instructions is not followed exactly, a fire or explosion may result causing property damage, personal injury or death.

- Do not store or use gasoline or other flammable vapors and liquids in the vicinity of this or any other appliance.
- **WHAT TO DO IF YOU SMELL GAS**
 - Evacuate all persons from the vehicle.
 - Shut off the gas supply at the gas container or source.
 - Do not touch an electrical switch, or use any phone or radio in the vehicles.
 - Do not start the vehicle's engine or electric generator.
 - Contact the nearest gas supplier or qualified service technician for repairs.
 - If you can not reach a gas supplier or qualified service technician, contact the nearest fire department.
 - Do not turn on the gas supply until the gas leak(s) has been repaired.
- Installation and service must be performed by a qualified installer, service agency or the gas supplier.

**WARNING**

If the information in these instructions is not followed exactly, a fire or explosion may result causing property damage, personal injury or death.

- Do not store or use gasoline or other flammable vapors and liquids in the vicinity of this or any other appliance.
- WHAT TO DO IF YOU SMELL GAS
 - Evacuate all persons from the vehicle.
 - Shut off the gas supply at the gas container or source.
 - Do not touch an electrical switch, or use any phone or radio in the vehicles.
 - Do not start the vehicle's engine of electric generator.
 - Contact the nearest gas supplier or qualified service technician for repairs.
 - If you can not reach a gas supplier or qualified service technician, contact the nearest fire department.
 - Do not turn on the gas supply until the gas leak(s) has been repaired.
- Installation and service must be performed by a qualified installer, service agency or the gas supplier.

Please read these instructions carefully and follow all instructions, guidelines, and warnings included in this product manual in order to ensure that you install, use, and maintain the product properly at all times. These instructions **MUST** stay with this product. By using the product, you hereby confirm that you have read all instructions, guidelines, and warnings carefully and that you understand and agree to abide by the terms and conditions as set forth herein. You agree to use this product only for the intended purpose and application and in accordance with the instructions, guidelines, and warnings as set forth in this product manual as well as in accordance with all applicable laws and regulations. A failure to read and follow the instructions and warnings set forth herein may result in an injury to yourself and others, damage to your product, or damage to other property in the vicinity. This product manual, including the instructions, guidelines, and warnings, and related documentation, may be subject to changes and updates.

CONTENTS

1 Explanation of Symbols and Safety Instructions	05
1.1 Recognize Safety Information	05
1.2 Understand Signal Words	05
1.3 Supplemental Directives	05
1.4 General Safety Messages	06
2 Intended Use	06
3 General Information	07
3.1 Unit Specifications	07
3.2 Component Locations	08
3.3 Technical Parameters	09
4 Installation	10
4.1 Preparing the Installation Location	11
4.2 Blocking the Water Heater	11
4.3 Installing the Water Hose	12
4.4 Installing the Gas Pipe	12
4.5 Installing the Wired Controller	13
4.6 Wiring the 120 VAC Power Supply	14
4.7 Wiring the 12 VDC Power Supply	15
4.8 Installing the Unit	18
4.9 Performing Leak Testing	19
5 Operation	20
5.1 Operating instructions	20
5.2 Wired controller operation	21
5.3 Thermostat Manual Reset	22
5.4 Shutting Down the Water Heater	23
5.5 High Altitude Use	23
6 Maintenance and Care	23
6.1 Performing Preventative Maintenance	24
6.2 Electronic Ignition Module Cleaning	24
6.3 Maintaining the Water Heater Tank	24
6.4 Operation and Maintenance T & P Pressure Relief Valve	26
6.5 Draining and Storage Instructions	27
6.6 Winterizing	28
6.7 Using After-Market Water Heating Element Devices	27
7 Troubleshooting	29
7.1 Fault Description and Troubleshooting	29
7.2 Non-defect When the Following Conditions Occur	30
8 Wiring Diagrams	31
9 Replacement Parts: Components	32
Warranty Policy	33
French	34

1 Explanation of Symbols and Safety Instructions

This manual has safety information and instructions to help you eliminate or reduce the risk of accidents and injuries.

1.1 Recognize Safety Information

 This is the safety alert symbol. It is used to alert you to potential physical injury hazards. Obey all safety messages that follow this symbol to avoid possible injury or death.

1.2 Understand Signal Words

A signal word will identify safety messages and property damage messages, and also will indicate the degree or level of hazard seriousness.



DANGER

Indicates an imminently hazardous situation which, if not avoided, will result in death or serious injury.



WARNING

Indicates a hazardous situation that, if not avoided, could result in death or serious injury.



CAUTION

Indicates a hazardous situation which, if not avoided, could result in property damage and minor or moderate injury.



NOTICE

This symbol indicates important information where there is no risk to people or property.

1.3 Supplemental Directives

To reduce the risk of accidents and injuries, please observe the following directives before proceeding to install or operate this appliance:

- Read and follow all safety information and instructions.
- Read and understand these instructions before installing, operating, or servicing this product.
- Installation and service must be performed by a qualified Service Technician, Service Center, OEM, or Gas Supplier.
- The installation must comply with all applicable local or national codes, including the latest edition of the following standards:

U.S.A.

- ANSI/NFPA70, National Electrical Code (NEC)
- ANSI/NFPA 1192, Recreational Vehicles Code
- ANSI Z223.1 National Fuel Gas Code
- Federal Mobile Home Construction & Safety Standard, Title 24 CFR, part 3280, or when this Standard is not applicable, the Standard for Manufactured Home Installations (Manufactured Home Sites, Communities and Set-Ups), ANSI A255.1
- ANSI Z21.10.1, Gas Water Heaters
- A119.5, Park Trailers

Canada

- CSA C22.1, Parts I & II, Canadian Electrical Code
- CSA Z240 RV Series, Recreational Vehicles
- CAN/CGA B149 Installation Codes
- CAN/CSA-Z240 MH Series, Mobile Homes
- CSA 4.1 (latest edition)

1.4 General Safety Messages



WARNING

This product can expose you to lead, which is known to the state of California to cause cancer and birth defects or other reproductive harm. For more information, go to www.P65warnings.ca.gov.



WARNING

Fire and/or explosion hazard

Failure to obey the following warnings could result in death or serious injury:

- Follow the information in this manual exactly.
- Do not store or use gasoline or other flammable vapors and liquids in the vicinity of this or any other appliance.



WARNING

Burn hazard, fire, explosion, and/or carbon monoxide hazard.

Keep the water heater area clear of combustible cleaning materials, gasoline, and other flammable vapors and liquids. Failure to obey this warning could result in death or serious injury.



FREEZE WARNING

Drain or fill with RV approved antifreeze if subject to freezing temperatures when storing for winter.



Disposal

Place the packaging material in the appropriate recycling waste bins, whenever possible. Consult a local recycling center or specialist dealer for details about how to dispose of the product in accordance with all applicable national and local regulations.

2 Intended Use

This Water Heater is designed and intended for use in a recreational vehicle (hereinafter referred to as "RV") for which it is supplied. This product is designed to heat water and is not intended to be used as a space heater for hydronic heating. This Water Heater is only suitable for the intended purpose and application in accordance with these instructions.

This manual provides information that is necessary for proper installation, operation, and maintenance of the Water Heater. Poor installation and/or improper operating or maintenance will result in unsatisfactory performance and a possible failure. The manufacturer accepts no liability for any injury or damage to the product resulting from:

- Incorrect assembly or connection, including excess voltage.
- Incorrect maintenance or use of spare parts other than original spare parts provided by the manufacturer.
- Alterations to the product without express permission from the manufacturer.
- Use for purposes other than those described in this manual.

3 General Information

This section provides reference information regarding the recommended installation tools and materials, the unit components, and the model identification associated with the different water heater models.



NOTICE

The images used in this document are for reference purposes only. Components and component locations may vary according to specific product models. Measurements may vary ±0.38 in. (10 mm).

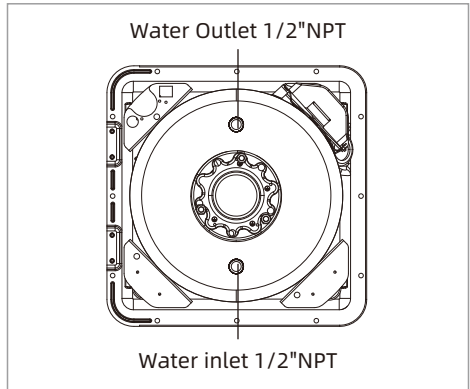

Model	FSGE-HS6	FSGE-HS10
A	15.0" (380 mm)*	18.5" (470 mm)
B	15.0" (380 mm)	18.5" (470 mm)
C	21.4" (544 mm)	20.6" (523 mm)
D	12.8" (324 mm)	16.3" (414 mm)

* FSGE-HS6 adjustable door frame: 15" or 18" Width.

3.1 Unit Specifications

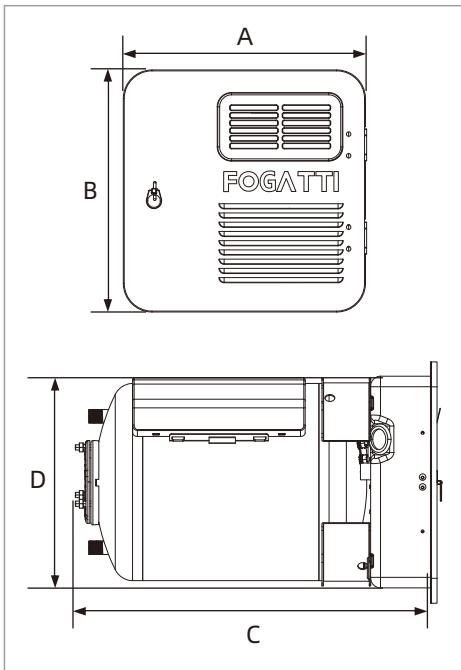

3.2 Component Locations

This section provides the component locations for each Water Heater model.

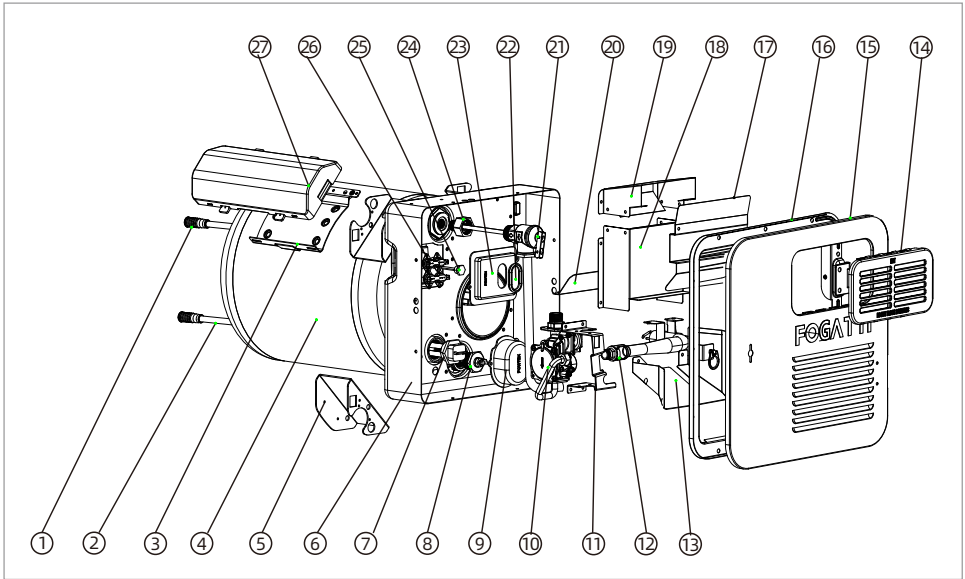

- | | |
|---------------------------|---|
| ① Water level pipe | ⑮ Panel assembly |
| ② Water diffuser | ⑯ Cabinet flange cover |
| ③ Controller bracket | ⑰ Deflector plate |
| ④ Water storage tank | ⑱ Top exhaust hood |
| ⑤ Metal bracket | ⑲ Front exhaust hood |
| ⑥ Metal shell | ⑳ Deflector plate |
| ⑦ Heating tube | ㉑ Temperature and Pressure Relief Valve |
| ⑧ Titanium rod | ㉒ Rubber grommet |
| ⑨ Heat pipe covers | ㉓ Thermostat cover |
| ⑩ Gas valve | ㉔ TP safety valve joint |
| ⑪ Regulator valve support | ㉕ Temperature probe |
| ⑫ Burner | ㉖ Thermostat |
| ⑬ Diversion hood | ㉗ Controller |
| ⑭ Smoke exhaust net | |

3.3 Technical Parameters

Water Heater Specifications Table

Model		FSGE-HS6	FSGE-HS10
Capacity (Gallons)		6 gallons	10 gallons
Range of adjustment		104 °F (40 °C); 122 °F (50 °C); 140 °F (60 °C);	
Max. Heat Input (Btu/hr)		12,000	12,000
Orifice Drill Size		40mil for LPG	
Max. Inlet Gas Pressure		13" wc (3.23 kpa)	
Min. Inlet Gas Pressure		8" wc (1.99 kpa)	
Total Input Current (A)		< 16	
Rated Gas Inlet Pressure		LPG 11" wc 2.74 kpa	
Ignition method		Pulse continuous ignition	
Nominal Input Voltage		12V DC (ignition and gas heating)	
Connector Specification	Gas inlet	5/8" UNF	
	Cold water inlet	1/2" NPT	
	Hot water outlet	1/2" NPT	
Electric supply		AC 120 V / 60 Hz	
Rated gas heating electric power (W)		7W ± 1W	
Rated electric heating power (W)		1440 W	
Max. Temperature		140 °F (60 °C)	

4 Installation



DANGER: CARBON MONOXIDE POISONING HAZARD.

This product can produce carbon monoxide, which has no odor and can be life-threatening. Avoid improper adjustment, alterations, service, or maintenance. Follow instructions for the proper installation of this appliance. Failure to obey this danger notification can result in improper installation causing carbon monoxide poisoning that will result in death or serious injury.



WARNING: FIRE AND/OR ELECTRICAL SHOCK HAZARD.

Failure to obey the following warnings could result in death or serious injury:

- Make sure there are no obstacles (wires, pipes, etc.) inside of the RV roof or walls at the installation locations.
- Shut off the gas supply, disconnect the 120 VAC power from RV, and disconnect the positive (+) 12 VDC terminal from supply battery before drilling or cutting into the RV.



WARNING: ELECTRICAL GROUNDING INSTRUCTIONS.

This appliance is equipped with a three-prong (grounding) plug for your protection against shock hazards and should be plugged directly into a properly grounded three-prong receptacle. Do not cut or remove the grounding prong from this plug. Failure to obey this warning could result in death or serious injury.



WARNING

The appliance should be located in an area where leakage of the tank or connections will not result in damage to the area adjacent to the appliance or to lower floors of the structure. When such locations cannot be avoided, it is recommended that a suitable drain pan, adequately drained, be installed under the appliance. The pan must not restrict combustion air flow.

This section describes how to install the Water Heater and control switch. Please consider the following directives prior to beginning installation:

- This appliance must be installed by a qualified professional installer.
- The water heater tank must be supported at the same level as the bottom of the sidewall cutout. Provide adequate clearance at the rear of the unit for easy service access to the water connections.
- If the appliance is installed where a connection or tank leakage can damage an adjacent area, install a drain pan (which can be drained outside of the RV) under the Water Heater.
- To install the Water Heater on carpeting, install the Water Heater onto a metal or wood panel that extends at least 3 in. (7.62 cm) beyond the total width and depth of the Water Heater.

4.1 Preparing the Installation Location

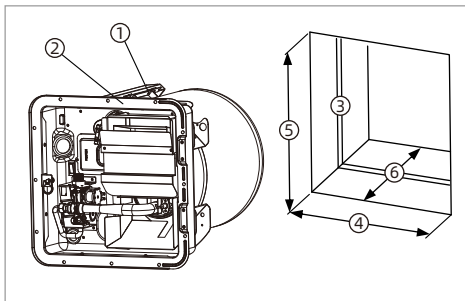

- ① Water Heater
- ② Flange
- ③ Cutout Frame
- ④ Cutout Width
- ⑤ Cutout Height
- ⑥ Cutout Depth

1. Plan the location of the Water Heater within the RV.
2. Erect the side walls and cut the square opening. Refer to the following tables for cutout and clearance specifications for basic water heater models.

Model	Cutout Width	Cutout Height	Cutout Depth
FSGE-HS6	13.0 in (330 mm)	13.0 in (330 mm)	21.4 in (544 mm)
FSGE-HS10	16.5 in (419 mm)	16.5 in (419 mm)	20.6 in (523 mm)

The cutout width and height tolerance is $\pm 1/8$ in. (± 3.0 mm) on all models.

The following table shows the requirements for the minimum clearance from combustible construction.

Sides	Back	Top	Bottom
0 in (0 mm)	0 in (0 mm)	0 in (0 mm)	0 in (0 mm)

The following figure and table show the minimum required clearances between the water heater vent and any projection or plastic part on the side of the RV.

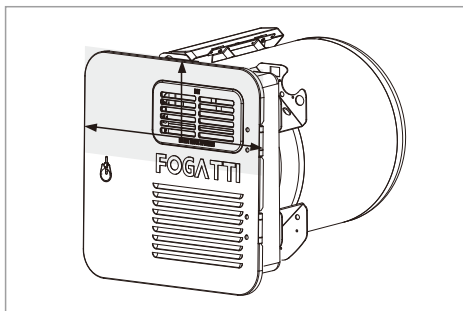

Sides	Top
3 in (76 mm)	12 in (305 mm)

3. Frame the cutout with 2 x 2 lumber or equivalent.
4. Bend all flanges 90° along the scored lines.
5. Block the Water Heater.

4.2 Blocking the Water Heater

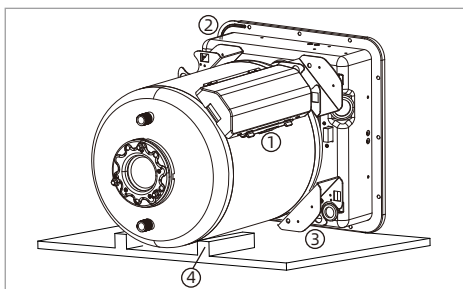

- ① Water Heater
- ② Cutout Frame
- ③ Floor
- ④ Wood Block

1. Place the Water Heater into the cutout location.
2. At the back of the cutout, measure the distance between the side of the cutout and the side of the Water Heater.
3. Remove the Water Heater from the cutout location.
4. Mark the appropriate measured distance taken in step 2 on each side along the back of the cutout.
5. Place a block of 2 x 2 lumber (minimum) that is at least 6 in. (15 cm) long at each marked location.
6. Secure the wood blocks to the floor.

4.3 Installing the Water Hose

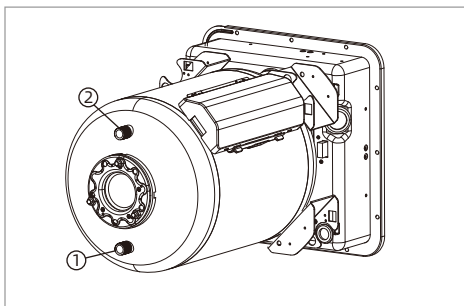

- ① Cold Water Inlet ② Hot Water Outlet

1. Position the Water Heater onto the planned location on the floor of the RV.
2. Remove the thread protector from the 1/2 in. (1.27 cm) hot water outlet.
3. Apply pipe sealant to the threads of the 1/2 in. (1.27 cm) National Pipe Tapered (NPT) hot water outlet hose.
4. Connect the 1/2 in. (1.27 cm) (NPT) hot water outlet hose to the proper fitting on the Water Heater using a suitable fitting.



NOTICE

Allow flexibility in the water and gas hoses so you can pull the unit forward through the wall 1 in (2.54 cm) past the skin.

5. Remove the thread protector from the 1/2 in. (1.27 cm) cold water inlet.
6. Apply sealant to the threads of the 1/2 in (1.27 cm) (NPT) cold water inlet hose.
7. Connect the 1/2 in (1.27 cm) (NPT) cold water inlet hose to the proper fitting on the Water Heater using a suitable plastic fitting.



CAUTION

If a water heater is installed in a closed water supply system, such as one having a backflow preventer in the cold water supply line, means shall be provided to control thermal expansion. Contact the water supplier or local plumbing inspector on how to control this situation.

4.4 Installing The Gas Pipe

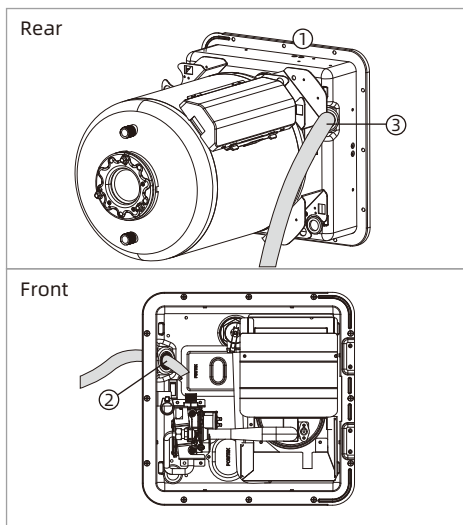

- ① Water heater ② Over the line sheath
 ③ Gas pipe

1. Connect the 5/8 in. (15.87 mm) flared L.P. gas pipe to the Water Heater.
2. Slide the grommet onto the 5/8 in. (15.87 mm) tubing.
3. Flare the gas pipe as necessary.

**NOTICE**

If the 5/8 in. (15.87 mm) gas pipe is already flared, cut the grommet on one side. Place the split grommet over the gas pipe and press it into the opening in the housing.

4. Pull the 5/8 in. (15.87 mm) gas pipe and grommet through the opening in the water heater housing.
5. Connect the flare fitting and press the grommet into the opening. Caulk around the grommet if the grommet was cut during the gas pipe installation.
6. Turn on gas and check all fittings and connections for leaks, using a soap and water solution. Correct even the slightest leak immediately.

**WARNING**

- It is imperative that grommet and gas pipe through grommet be caulked air tight. If not tightly sealed, moisture and potential harmful flue products could vent through opening and into living area of trailer.
- Do not use an open flame to check for leaks!

4.5 Installing the Wired Controller

Recommends that the Water Heater unit be connected directly to a 12 VDC battery or to the filtered side of an AC/DC converter. Avoid connections to the unfiltered side of an AC/DC converter whenever possible. Use a minimum of 18-gauge wire, UL and CSA listed.

**NOTICE**

The 12 VDC control wiring in the Water Heater is 18-gauge stranded wire rated for 105 °C (221 °F). This 18-gauge wire should be sufficient for the 12 VDC control wire coming from the Water Heater to the switch and the 12 VDC power source; however, consult all local and national codes relating to your specific installation to verify.

4.5.1 Preparing the Wired Controller Installation Location

**WARNING: FIRE AND/OR ELECTRICAL SHOCK HAZARD.**

Failure to obey the following warnings could result in death or serious injury:

- Make sure there are no obstacles (wires, pipes, etc.) inside of the RV roof or walls at the installation locations.
- Shut off the gas supply, disconnect the 120 VAC power from RV, and disconnect the positive (+) 12 VDC terminal from supply battery before drilling or cutting into the RV.

When planning the location of the control switch(es), be sure to choose an easily accessible area for both use and service.

4.5.2 Completing the Wired Controller Installation

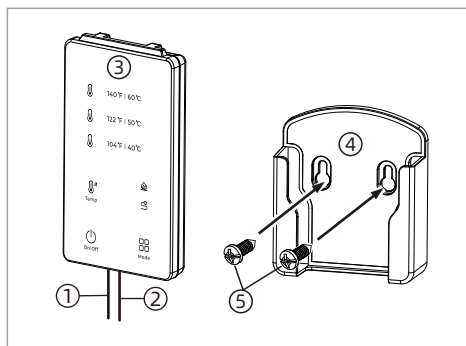

- ① Red wire ② White wire
 ③ Wired controller ④ Wired controller base
 ⑤ 2-ST4X16

1. Mount the controller base in a suitable location using two ST4×16mm screws.
2. After mounting the base, complete the wiring of the controller.
 - Red Wire: Connect the controller’s red wire to the appliance’s blue wire (Signal Wire - for communication only).
 - White Wire: Connect the controller’s white wire to the appliance’s black wire (GND), which should also be connected to the negative terminal of the 12V DC power supply.



NOTICE

- For new installations, use the provided 2-core shielded cable with plug-and-play connection, and route the cable to the appliance.
- For replacement of an old unit, you may reuse the existing wiring by connecting it through terminals. Also, use the included red power adapter cable to supply +12V power to the appliance.

- For detailed wiring instructions, refer to section 4.7 of this manual.



NOTICE

- Only the original wired controller provided by this company must be used. Use of third-party or non-original controllers may cause malfunction or create safety hazards.

4.6 Wiring the 120 VAC Power Supply



WARNING: FIRE HAZARD.

When a cord and plug connection to the power supply are used on a water heater, the power cord must be UL listed as suitable for damp locations, hard or extra hard usage. The cord must be a flexible type such as S, SO, ST, STO, SJ, SJT, SJTO, HS or HSO described in the National Electric Code ANSI/NFPA 70. The length of the external cord to the water heater, measured to the face of the attachment plug, shall be no less than 2 ft (60.96 cm) and no more than 6 ft (182.88 cm). The supply cord must be a minimum of 14 AWG. The attachment plug must be rated at 15 A. Failure to obey this warning could result in death or serious injury.



NOTICE

Do not route wires around sharp objects or where it could be smashed.

**NOTICE**

When using Romex® with a bare earth ground, be sure to position the ground wire so it does not contact the heating element terminals. Damage to the ground wire can occur.

**NOTICE**

Refer to "Wiring Diagrams" for a comprehensive wiring schematic.

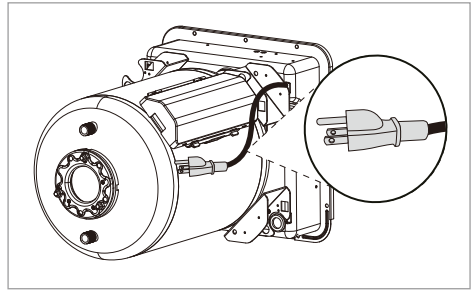

Consider the following before wiring the control switch:

- The three-prong plug must be secured to a UL approved, dedicated, minimum 15 A-rated, three prong receptacle.
- All wiring must comply with applicable electrical codes.
- Use electrical metallic tubing, flexible metal conduit, metal clad cable, or nonmetallic-sheathed cable with a grounding conductor.
- Wires must have a capacity of 1400 W or greater.
- The wiring method must conform to applicable sections of article 551 of National Electrical Code
- ANSI/NFPA 70.
- The receptacle must be located per all applicable codes and away from any water.

**WARNING**

The 120V AC power supply must be connected. If the power supply is not connected correctly, the water heater will not start and the controller will be damaged, which may result in serious injury or death.



4.7 Wiring the 12 VDC Power Supply (Updated for Three-Wire System)

**WARNING: ELECTRICAL SHOCK HAZARD**

Disconnect all power before performing any work. Always use a certified and properly grounded 12V power supply that is isolated from the RV. Follow all applicable codes, regulations, and instruction materials when performing service work. Failure to follow instructions could result in serious injury or death.

- Wiring connected to or in proximity to the appliance must be rated for a minimum temperature of 140 °F (60 °C). Use only insulated terminals for all electrical connections.
- This appliance requires a 12 V DC power source that provides a stable voltage between 10 V and 17 V to operate correctly.

Updated Wiring Configuration:

The wiring system has been upgraded to a three-wire design to simplify installation and improve reliability:

- Red: +12V Power Supply (direct connection to the power supply positive terminal)
- Black: GND (shared ground for both the appliance and the controller; connect to the power supply negative terminal and the controller's white wire)
- Blue: Signal Wire (used exclusively for controller communication)

This replaces the previous 4-wire configuration, which used separate GND lines and signal/power separation between the appliance and the controller.

Wiring Preparation Tips:

1. Select a distribution branch rated greater than 3A (preferably 15A) to provide 12V to the appliance from the RV's distribution panel.

NOTE: The appliance features a built-in 10A fuse, accessible for service from the front. It may be installed on a dedicated or shared circuit.

2. (Optional) You may add a 12V switch in the RV's living area for convenience, although the unit already includes an external power switch.

If added, ensure any inline fuse or switch is rated for at least 3A.

3. Locate the wiring entry point at the rear of the appliance. Ensure the entry is not within the appliance footprint and all edges are protected to prevent abrasion.
4. Determine the appropriate wire gauge (AWG) based on the wire length:
 - 16 AWG: up to 40 feet (12 meters)
 - 14 AWG: up to 66 feet (20 meters)
5. Feed the wires from the power source to the entry point and make all secure connections using insulated connectors, as shown in the wiring diagram.



WARNING

The 12V DC power supply must be connected correctly. Incorrect wiring (especially reversed polarity or missing connections) will prevent the heater from starting and may damage the controller, resulting in serious injury or death.

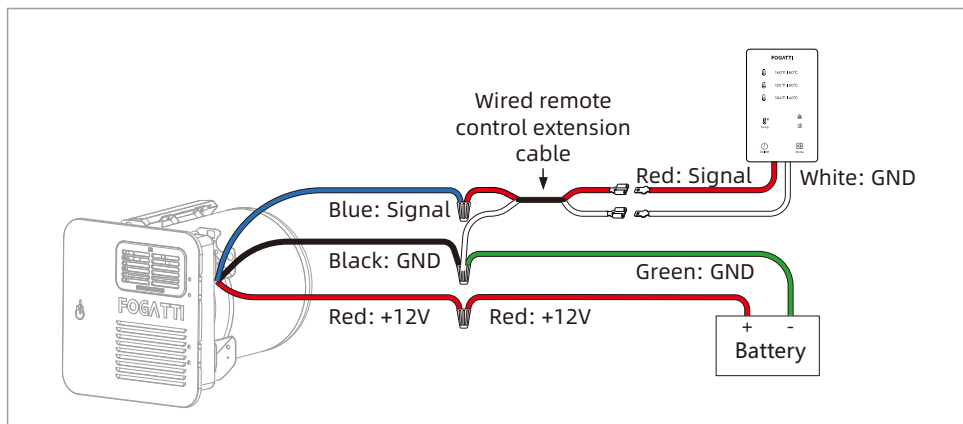

Replacing an Existing RV Water Heater

In addition to standard installation, this appliance supports fast replacement of older RV water heaters. This method enables you to reuse existing wiring, thereby minimizing the time required for rewiring.



WARNING

Before beginning any work, disconnect all power sources to the RV. Improper handling of electrical wiring can result in serious injury or death. Always follow applicable safety codes and use insulated tools and connectors.

Quick Replacement Steps:

1. Remove the original RV water heater.

Identify and clearly label the three original connection wires that will be reused. These are typically color-coded as follows:

- Red: +12V DC Power (positive)
- Green: GND (negative / chassis ground)
- Blue: Signal Wire (controller communication line)

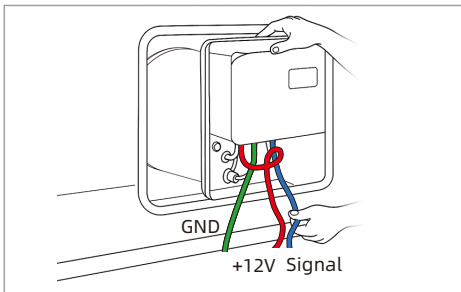

2. Remove the old wired controller.

Unplug the existing controller connector and label the four exposed wires. These typically include:

- Red (x2): One for +12V IN (from RV power), one for +12V OUT (to the appliance).
- Blue: Signal wire (same as the original blue wire connected to the appliance)

- Green: GND wire (same as the original GND connected to the appliance)

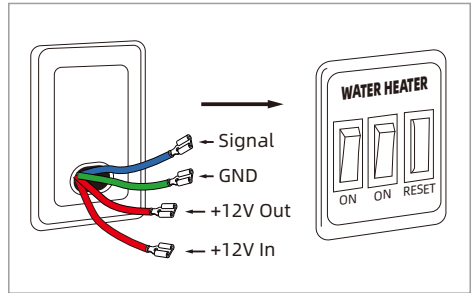

3. Reconnect wires to the new appliance and controller:

- Connect the blue signal wire from the appliance to the red wire on the new controller (signal wire input).
- Connect the GND wire (green) from the appliance to the white wire on the new controller (GND/Negative).
- Use the included T-tap or quick-connect terminals to join the +12V IN and +12V OUT wires together (red to red).

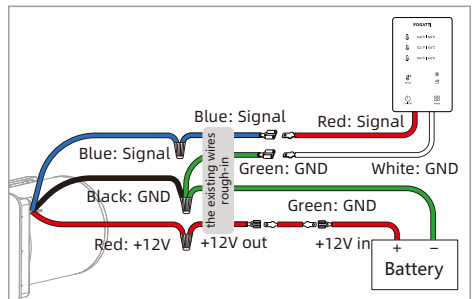

WARNING

Ensure correct polarity and continuity before powering the unit. Reversed or incorrect wiring may prevent the system from functioning or cause damage to the controller.

4.8 Installing the Unit



WARNING: CARBON MONOXIDE, FIRE AND/OR EXPLOSION HAZARD.

Failure to obey the following warnings could result in death or serious injury:

- Be sure the unit is vented and sealed properly to avoid the collection of carbon monoxide inside of the RV.
- All combustion air must be supplied from outside of the RV. All combustion products must be vented to the outside of the RV.
- Do not vent the water heater with a venting system that serves another appliance.
- Do not vent the water heater to an outside enclosed porch area.
- Protect building material from flue gas exhaust.
- Install the water heater on an exterior wall with access to a door opening to the outdoors.
- Do not alter the water heater for a positive grounding system.
- Do not high-potential test (HI-POT) the water heater unless the DSI control board has been disconnected (DC HI-POT).
- Do not use a battery charger to supply power to the water heater at any time or when testing.



CAUTION

- Do not modify the water heater in any way.
- Do not lift, push, or misalign the main burner tube. Damage to the burner and the water heater can occur.



WARNING: Vertical Installation Only

- This appliance must be installed in an upright (vertical) position only.
- Do not install the unit on its side under any circumstances.
- Improper orientation may cause internal overheating, which could result in malfunction, equipment damage, or a serious fire hazard.
- Always follow the specified installation orientation to ensure safe and reliable operation.



NOTICE

Install in recreation vehicles only. RVs are recreation vehicles designed for temporary living quarters for recreation, camping, or travel using their own power or towed by another vehicle.

1. The door of the rv water heater is fixed to the mounting flange by a latch. You need to rotate the door lock to open the door.
2. Remove the access door from the box, separate the components.

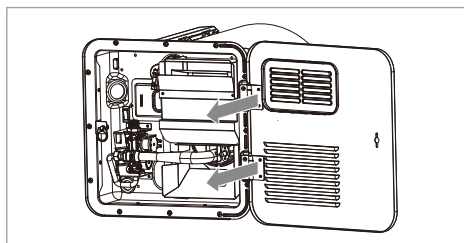

3. Caulk thoroughly around the opening and the flange slots.

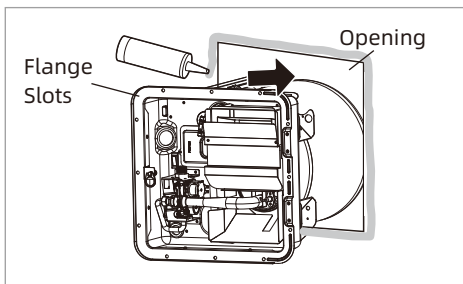
**NOTICE**

Butyl tape 1-1/4 in. x 1/8 in. (32 mm x 3 mm) may be substituted for caulking material.

4. Press this product into the opened hole. Secure the water heater to the car body with 12 screws (ST5x25 mm) Air and water should be isolated from the openings to prevent entry into the interior of the RV.

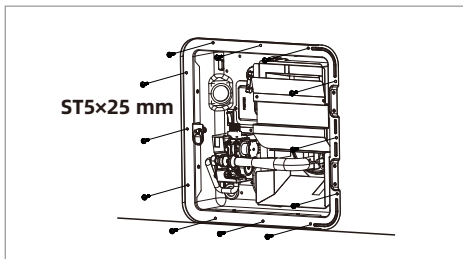

5. Apply a liberal amount of sealant around the door frame to fill any gaps to the RV wall wipe any excess sealant.

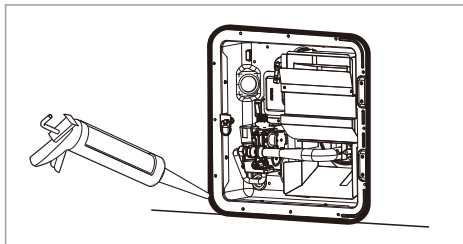

6. Install the water heater door.

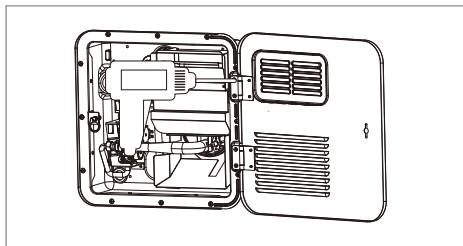

4.9 Performing Leak Testing

**WARNING: FIRE AND/OR ELECTRICAL SHOCK HAZARD.**

Do not use matches, candles, or other sources of control when checking for gas leaks. Failure to obey this warning could result in death or serious injury.

**NOTICE**

Isolate the Water Heater from the gas supply piping system before performing any pressure test equal to or greater than 0.5 PSI (34.5 mbar).

1. Turn on the gas and check the Water Heater and all of the connections for gas leaks using leak detection solution.
2. Fill the water heater tank with water.
3. Check the tank and all water hose connections for leaks.

5 Operation



WARNING: CARBON MONOXIDE, FIRE AND/OR EXPLOSION HAZARD.

Failure to obey the following warnings could result in death or serious injury:

- Do **not** store or use gasoline or other flammable vapors and liquids in the vicinity of this or any other appliance.
- Should overheating occur, or the gas supply fail to shut off, turn the operating switch to the OFF position and close the gas valve to stop the gas supply.
- Use with L.P. gas only.
- Shut off gas appliances and pilot lights when refueling.
- Turn gas off at the L.P. tank when the vehicle is in motion. This disables all gas appliances and pilot lights.
- Gas appliances must never be operated while the vehicle is in motion. Unpredictable wind currents may be created which could cause flame reversal in the burner tub, which could result in fire damage. The thermal cut off fuse could also be unnecessarily activated resulting in a complete shutdown of the water heater requiring replacement of the thermal cut off.



WARNING: Burn hazard, fire, explosion, and/or carbon monoxide hazard.

Keep the water heater area clear of combustion cleaning materials, gasoline, and other flammable vapors and liquids. Failure to obey this warning could result in death or serious injury.



CAUTION: FIRE HAZARD.

Do **not** smoke or have any flame near an open faucet. Failure to obey this caution could result in minor or moderate injury.



CAUTION: Explosion hazard.

If water heater has not been used for more than two weeks, hydrogen gas may form in the water line. Under these conditions, to reduce the risk of injury, open the hot water faucet for several minutes at the kitchen sink before you use any electrical appliance connected to hot water system. If hydrogen gas is present, you will probably hear sounds like air escaping through the pipe as water begins to flow. Failure to obey this warning could result in death or serious injury.

5.1 Operating instructions

- Users should confirm whether the water heater is installed correctly before the first use, and carefully check whether the connection is correct without leakage.
- Confirm that the power switch to the water heater is turned on, turn the latch to close the door.

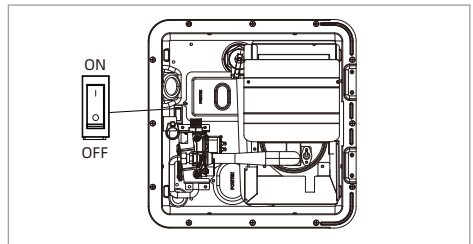

- During and after the operation of the water heater, the temperature at the exhaust outlet and the surrounding part is high. Please do not touch either with your hands to avoid burns.
- Before showering or bathing, test the water temperature with your hands to avoid burns.



NOTICE

It is imperative that the water heater tank be filled with water before operating the water heater. Operation of the water heater without water in the tank may result in damage to the tank and /or controls. This type of damage is not covered by the limited warranty.

5.2 Wired controller operation

- The thermostat is adjusted to its lowest temperature position when shipped from the factory.
- Wired controller to adjust desired temperature.
- Procedures for adjusting the thermostat for energy efficient operation at the minimum water temperature setting consistent with the consumer’s needs.
- There is a hot water scald potential if the thermostat is set too high.
- Valves for reducing point of use temperature by mixing cold and hot water are available.

Consult a licensed plumber or the local plumbing authority.

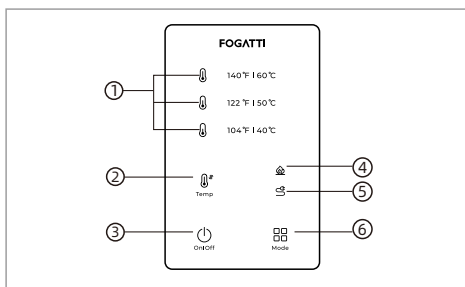

- ① Temperature display
- ② Temperature adjustment button
- ③ ON/OFF button
- ④ Gas heating display
- ⑤ Electric heating display
- ⑥ Heating mode button



ON/OFF button:

1. switch between on and off status.
2. On/Off Indicator: When the power is turned on, the indicator will be permanently on. When the power is off, the indicator will be shut off.
3. In the case of a system failure, pressing this button clears the fault code.
4. Fault indication: When a failure occurs, the "On/Off button indicator" flashes a matching number of times to show the various problems.



Temperature adjustment button:

At each press, the preset temperature of 104 °F (40 °C), 122 °F (50 °C) and 140 °F (60 °C) can be selected and switched in cycles.



Heating mode button:

At each press, select gas heating mode, electric heating mode, gas and electric simultaneous heating mode cycle switching.



Temperature indicator:

The temperature display lights up in red when heating. The temperature display lights up in green when heated to the preset temperature.



Heating mode display:

When gas heating is selected, the gas heating indicator will be on. When electric heating is selected, the electric heating indicator will be on. When the gas and electric heating mode is selected, the gas and electric heating indicator will be on.

Power supply display:

For one second, all lights are turned on. The mode of the most recent power outage is also displayed, as are the lights for the selected temperature.

Buzzer:

1. When the heater is powered on or a proper key operation is made, the buzzer makes a "B" sound.
2. After a fault, the buzzer will sound continuously for 30 seconds and may be deactivated by hitting any key.
3. When the heater reaches the preset temperature, the buzzer will sound once and enter into heat preservation state.

5.2.1 Gas Heating Mode



WARNING: Burn hazard, fire, explosion, and/or carbon monoxide.

Keep the water heater area away from combustible cleaning materials, gasoline, and other flammable vapors and liquids. Failure to comply with this warning may result in death or serious injury.

When the power switch turns to the ON position, click the switch button, select the temperature that needs to be heated, and then select the gas heating mode, the gas heating indicator lights up, and the water heater starts to try to ignite. If for some reason there is no ignition, the switch indicator on the remote controller flashes twice and beeps an alarm.

5.2.2 Electric Heating Mode

When the power switch turns to the ON position, click the switch button, select the temperature that needs to be heated, and select the electric heating mode, the electric heating indicator lights up, and the relay closes and passes 120 VAC to the heating tube. If the water heater fails, the switch indicator on the wire controller flashes twice and beeps an alarm.

5.2.3 Gas and Electric Simultaneous Heating Mode

When the power switch turns to the ON position, click the switch button, select the temperature that needs to be heated, and then select the gas-electric heating mode, the gas and electric heating indicator lights up. If the gas fails to ignite, the gas mode will lock, the switch indicator flashes 3 times, and beeps the alarm because the electric heating mode is still running; If the electric heating mode is locked and the gas heating mode is operating normally, the switch indicator will flash 4 times and beep the alarm.

5.3 Thermostat Manual Reset

If the Water Heater fails to operate due to high-water temperature, a lockout condition will occur. Investigate the cause of overheating and correct the issue before resetting the Water Heater.

Investigate the cause of the overheating then perform the following to reset the Water Heater:

1. Allow water to cool.
2. Place the control switch in the OFF position and wait 30 seconds.
3. Turn the control switch to the ON position.
4. Open the door panel and press the button as shown below to reset the thermostat.

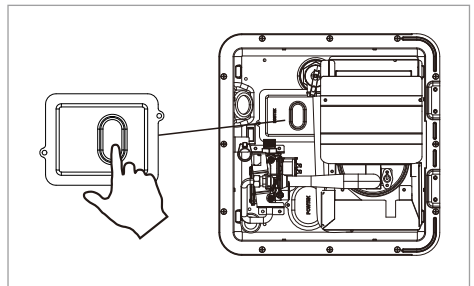

If the lockout condition persists:

1. Read the Maintenance and Care Instructions and the Electronic Control Maintenance in this manual.
2. Contact a Service Center.

5.4 Shutting Down the Water Heater

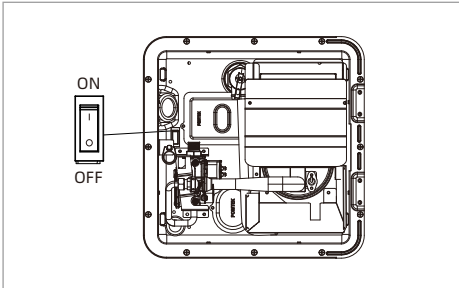

NOTICE

Perform these steps before performing any service on the Water Heater.

1. Place the control switch in the OFF position.
2. Turn the power switch to the OFF position.

5.5 High Altitude Use

For Canada: 0~4500 ft above sea level;

For US: 0~5000 ft above sea level.

If it exceeds 5000 ft, it shall comply with the requirements of Canadian installation regulations CSA B149.1 and American installation regulations ANSI Z223.1/NFPA54, and the input rate will decrease by 4% for every 1000 ft increase in altitude.

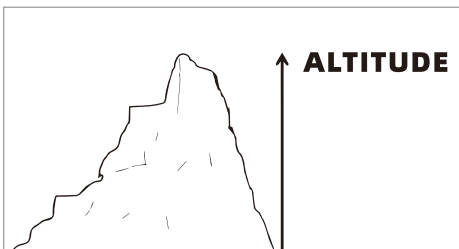

6 Maintenance and Care



WARNING: Carbon monoxide poisoning hazard.

Gas flames consume oxygen, which must be replaced to assure proper combustion. Provide fresh air during testing, service, and maintenance of this appliance. Failure to obey this warning can result in death or serious injury.



WARNING: Fire or explosion hazard.

Failure to obey the following warnings could result in death or serious injury:

- When performing any maintenance or care, shut off the gas supply at the L.P. container before disconnecting a gas line.
- Keep the control compartment clean and free of gasoline, combustible material and any flammable liquids and vapors.



NOTICE

- During service of the controls, label all wires before disconnecting any wires.
- Verify proper operation after servicing.

Have the gas pressure tested periodically. The pressure should be set at 11 in. (27.94 cm) of water column with three appliances running.

Have the gas pressure tested periodically. The pressure should be set at 11 in. (27.94 cm) of water column with three appliances running.

Drain the Water Heater at regular intervals (at least one time during the year).

Drain the Water Heater before storing the RV for the winter or when the possibility of freezing exists.

Keep the vent and combustion air grill clear of any obstructions.

Periodically check the main burner flame.

6.1 Performing Preventative Maintenance

Spiders, mud wasps, and other insects can build nests in the burner tube. This will cause poor combustion, delayed control, or flame outside of the combustion tube and the burner assembly.

Listen for a change in burner sounds or look for changes in flame appearance from a hard blue flame to a soft lazy flame or one that is very yellow. These are indications of an obstruction in the burner tube or the burner assembly.

Inspect and clean the burner tube on a regular basis. Run a flexible wire brush down the burner tube to remove obstructions or clean the burner tube and the burner assembly.

1. Inspect the main burner orifice.
2. Clean and adjust the main burner.
3. Ensure the main burner and the valve manifold are aligned with each other.
4. Inspect the electrode for cracked porcelain.
5. Ensure the electrode gap between the electrode and the ground is 0.125 in. (0.3175 cm).
6. Check for intermittent functionality of the DSI control board. If the DSI control board is experiencing intermittent functionality, remove the DSI control board and clean the terminal block with a pencil eraser.

6.3 Maintaining the Water Heater Tank



CAUTION: Scalding hazard.

Turn off the water heater and allow time for the water to cool before removing the drain plug to flush the water heater tank. Failure to obey this caution could result in minor or moderate injury.

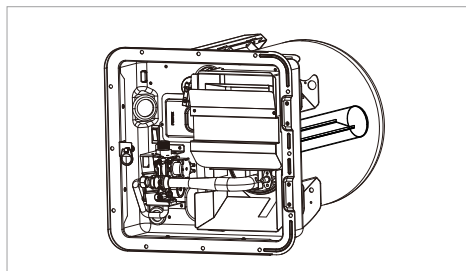

6.2 Electronic Ignition Module Cleaning

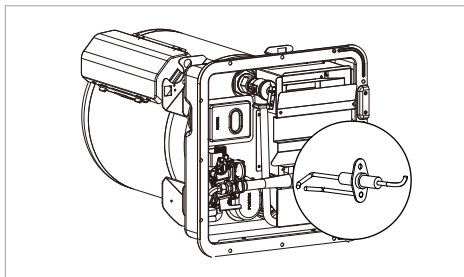

6.3.1 Winterizing the Unit



NOTICE

- To ensure the best performance of the Water Heater and to extend the life of the tank, periodically drain and flush the water heater tank.
- Drain and flush the tank before long term storage or freezing weather.

1. Turn off the main water supply (the pump, the water supply, or the water hook up source) then lift the handle on the T & P relief valve. This will allow water to flow out of the drain opening.

2. Drain the water heater tank by removing the drain plug.

After draining the tank, because of the placement of the drain plug, approximately two quarts of water will remain in the tank. This water contains most of the harmful corrosive particles. To remove these harmful corrosive particles, flush the tank with either air or water. Whether using air or water pressure, it may be applied through the inlet or outlet on the rear of the tank or the T&P relief valve. (If using the T&P relief valve, the handle must be pulled straight out). The pressure will force out the remaining water and the corrosive particles.

If you use water pressure, pump fresh water into the tank with the assistance of the on-board pump or use external water for 90 seconds to allow the fresh water to agitate the stagnant water on the bottom of the tank and force deposits through the drain opening. Continue adding water and draining until the particles have been cleared from the water remaining in the tank. If sporadic water flow is encountered, open the T & P relief valve to allow air into the tank. Using a small gauge wire or coat hanger, poke through the drain opening to eliminate any obstructions.

3. Replace the drain plug and close the T&P relief valve.

**NOTICE**

The two quarts of water remaining in the tank after draining the tank will not cause damage to the tank should freezing occur.

6.3.2 Flushing the Tank

Use this procedure for general flushing of the water heater tank.

1. Turn off the main water supply (the pump or water hook up source).
2. Remove the drain plug to drain the water from the tank.

**NOTICE**

If the water drains sporadically or trickles out of the drain hole, open the T&P relief valve then use a small gauge wire or coat hanger to remove any obstructions from the drain hole.

With the tank drained, approximately two quarts of water remain at the bottom of the tank. This water contains most of the corrosive particles. To remove these particles, use an "RV Water Heater Flushing Tool." The wand of this flushing tool allows the water jet to clean at different angles inside of the tank. Cleaning at different angles inside of the tank will suspend and flush the corrosive particles out of the drain coupling.

3. Continue flushing the tank until the water being flushed from the drain coupling is draining as clear water.
4. Replace the drain plug.

6.3.3 Flushing to Remove Unpleasant Odor

A rotten egg odor (hydrogen sulfide) may be produced when the electro-galvanic action of the cladding material releases hydrogen from the water. If sulfur is present in the water supply, the two will combine and produce an unpleasant smell.

1. Turn off the main water supply.
2. Remove the drain plug to drain the water heater tank.
3. Reinstall the drain plug.

4. Remove the T&P relief valve.
5. Mix a solution of four parts white vinegar to two parts water.
6. With a funnel, carefully pour the solution into the tank.
7. Cycle the Water Heater with the vinegar/water solution, letting it run under normal operation four to five times.
8. Remove the drain plug and thoroughly drain all of the water from the tank.
9. Flush the Water Heater to remove any sediment. You may flush the tank with air pressure or fresh water. Pressure may be applied through either the inlet or outlet valves on the rear of the tank or through the T&P relief valve coupling located on the front of the unit. If flushing through the T&P relief valve, lift the handle and apply the air pressure.

6.4 Operation and Maintenance T & P Pressure Relief Valve



WARNING: EXPLOSION OR SCALDING HAZARD.

Failure to obey the following warnings could result in death or serious injury.

- Do not tamper with the T&P relief valve.
- Do not place a valve, plug or reducing coupling on the outer part of the T&P relief valve.
- No valves shall be placed between the pressure relief valve and the tank.



NOTICE

- The T & P relief valve is a safety component and must **not** be removed for any reason other than replacement.
- Tampering with the T & P relief valve will void the warranty.

Temperature and Pressure Relief Valve Drain Operation Instruction

The user must check the temperature and pressure relief valve at least once a year. When checking, turn off the water heater's power supply and gas. Turn on the water inlet switch to create pressure in the water system. Then gently open temperature and pressure relief valve handle until there is water out and then gently close, if there is no water out, indicating that the valve is invalid, this time should immediately turn off the water heater water switch and ask the service personnel to deal with. Before operating the handle, check the discharge line connecting the valve to ensure that the water drained from the valve can be drained to a suitable place.

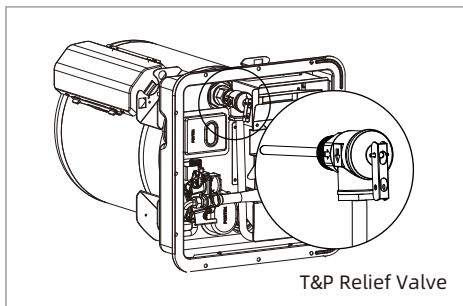

The T & P relief valve is not serviceable. If the T & P relief valve is found to be faulty, replace the valve.

This water heater is equipped with a T&P relief valve that complies with the standard for Relief Valves and Automatic Gas Shutoff Devices for Hot Water Systems, ANSI Z21.22.

If a discharge line is used, do not use a reducing coupling or other restriction smaller than the outlet of the T & P relief valve. Allow both the valve and the line to completely drain.

A T & P relief valve dripping while the Water Heater is running does not mean it is defective. During normal expansion of water, as it is heated in the closed water system of an RV, may cause the T&P relief valve to drip. The water heater tank is designed with an internal air gap at the top of the tank to reduce the possibility of dripping. Over time, the expanding water will absorb this air and it must be restored. Due to variations in water quality, the T&P relief valve may have a shorter life and may need replacement within the Water Heater warranty period. If corrosion is detected, it will not be covered under warranty.

Water Weeping or Dripping From Pressure Relief Valve

You may experience water weeping or dripping from your water heater's Pressure and Temperature (T & P) Relief Valve when your water heater is operating. Water weeping or dripping from the T & P Valve does not always mean the T & P Valve is defective. As water is heated, it expands. The water system in a recreational vehicle is a closed system and does not allow for the expansion of heated water. When the pressure of the water system exceeds the relieving point of the T & P Valve, the valve will relieve the excess pressure.

Recommends that a check valve not be installed directly at the inlet to the water heater tank. This will increase weeping of the pressure relief valve.

Replacement T & P Relief Valve Parts

- Do not install anything less than a combination T & P relief valve certified by a nationally recognized testing laboratory that maintains periodic inspection of product of listed equipment or materials, as meeting requirements for Relief Valves and Automatic Gas Shutoff Devices for Hot Water Supply Systems, ANSI Z21.22. The Valve must have a maximum set pressure not to exceed 150 PSI (1034.21 kPa).

- Install the valve into the provided opening marked for this purpose on the Water Heater.
- Installation must conform with local codes or in the absence of local codes, American National Standard for Recreational Vehicles, ANSI A119.2/NFPA 501C.
- For an external electrical source, ground this unit in accordance with National Electrical Code ANSI/NFPA70.

6.5 Draining and Storage Instructions

If RV is to be stored during winter months, the water heater must be drained to prevent damage from freezing.

1. Turn off electrical power to water heater either at the switch from the electrical element or a breaker.
2. Shut off gas supply to water heater.
3. Turn off pressure pump on water system.
4. Open both hot and cold water faucets.
5. Remove anode rod from tank. The anode rod is accessible at the front of the water heater.
6. Follow RV manufacturer's instructions for draining entire water system.



NOTICE

Be certain to refill water heater with water and remove all air from tank and lines before re-lighting or before turning on electrical power.

6.6 Winterizing

If your water heater plumbing system is equipped with a bypass kit, use it to close off the water heater, drain the water heater completely and leave the water heater closed off (out of the system) in the bypass position particularly if you are introducing antifreeze into the plumbing system. Antifreeze can be very corrosive to the anode rod creating premature failure and heavy sediment in the tank. If the plumbing system is not equipped with a bypass kit, and you intend to winterize by adding antifreeze to the system, remove the anode rod (storing it for the winter) and replace it with a 3/4" drain plug.

6.7 Using After-Market Water Heating Element Devices



WARNING: EXPLOSION AND OR BURN INJURY.

Failure to obey the following warnings could result in death or serious injury:

- Do not use after-market heating elements. After market heating elements can lack critical safety controls.
- Do not use bug screens, anode rods or other non-approved devices with this water heater.
- The use of after-market heating elements can lead to uncontrolled water tank heating and tank explosion.



NOTICE

- The use of any after-market heating element devices may result in damage to components or the water heater.
- Any alteration, such as the addition of an after-market heating element device, will void the warranty.

7 Troubleshooting

7.1 Fault Description and Troubleshooting



NOTICE: Air in the Gas Line

During the first installation or after replacing gas components, there may be residual air inside the gas pipeline. It may take multiple ignition attempts before propane gas reaches the water heater. This is normal and not a malfunction. Once the air is purged, the unit should ignite and operate properly.



NOTICE

- The fault indicator light refers to the power button light on the wired controller.
- The flashing of the indicator light indicates an abnormal operating condition.
- If the issue is resolved and the system returns to normal, the heater may continue to operate.
- If the problem persists and the heater fails to function, please contact technical support.

■ Fault Codes

LED Blink Pattern	Failure name	Problem Description
1-time Blink	Water probe failure	The water probe is either open or short-circuited. All solenoid valves and heating elements are shut off. The indicator light blinks once per cycle and a continuous buzzer sounds.
2-time Blink	Ignition / Flame Failure	Detected failure in ignition, unexpected flame-out during operation, or false flame signal before ignition. The gas system shuts down. The indicator light blinks twice rapidly, and the buzzer sounds.
3-time Blink	Valve or Thermostat Failure	A valve short or open circuit was detected before or during operation. Gas operation stops. The indicator light blinks three times, and the buzzer sounds.
4-time Blink	Heating Element Failure	The heating element is missing or faulty. Electric heating is disabled. The indicator light blinks four times, accompanied by an audible alert.
6-time Blink	Electronic Anode Failure	A short circuit was detected in the electronic anode. Both gas and electric heating are disabled. The system requires a power reset and restoration of the anode before it can function again.

■ Fault Reset Method

If any of the above error codes appear:

1. Make sure the water and gas supplies are normal.
2. Press the power button on the wired controller to turn off the heater.
3. Wait 5 seconds, then turn it back on.
4. If the error persists, please contact after-sales service.

7.2 Non-defect When the Following Conditions Occur:

Phenomenon	Reason and handling method
White smoke at exhaust	When the outdoor temperature is too low, the exhausted smoke encounters outdoor cold air and condenses into a white mist.
Failure to provide hot water during winter	The water temperature is too low, the water flow exceeds the heating capacity of the water heater. Please adjust the amount of water appropriately.
After opening, hot water does not come immediately	On the one hand, the time lag between the hot water valve and machine body may be the reason. On the other hand, the existed cold water within pipeline takes time to be showered out, the longer the pipeline, the longer time it takes.



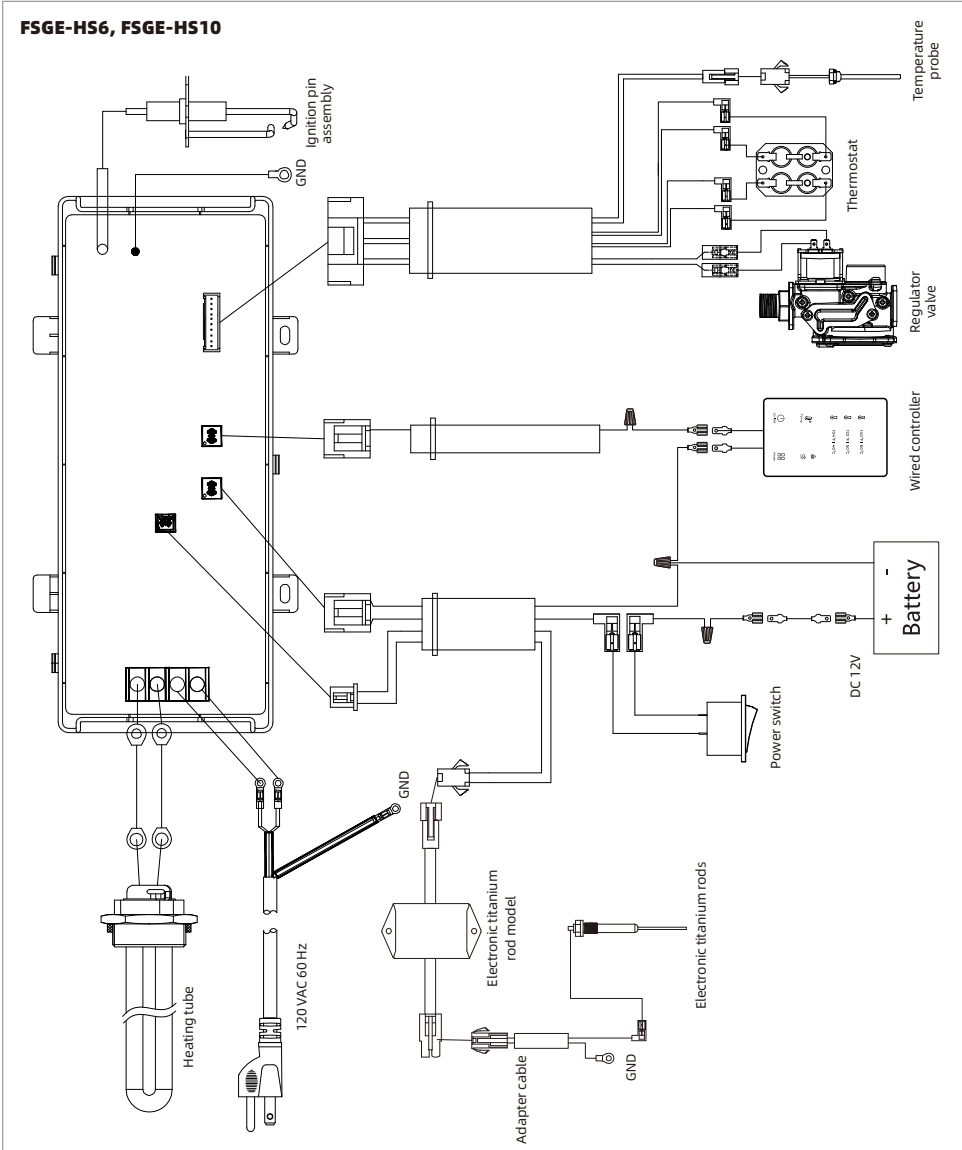



8 Wiring Diagrams

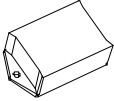
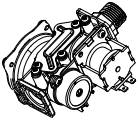
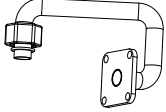
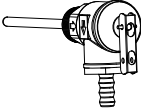

NOTICE

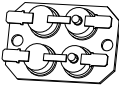
Label all wires prior to disconnecting when servicing controls. Wiring errors can cause improper and dangerous operation. Verify proper operation after servicing.

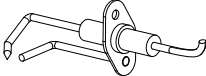
9 Replacement Parts: Components

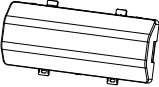
Parts	Photo	Parts	Photo
Lock		Electronic titanium rod module	
Gas control valve		Intake connecting pipe	
Temperature and Pressure Relief Valve		Wired Controller	
Thermostat		Electronic titanium rods	
Ignition pin assembly		Water Outlet temperature probe	
Heating pipe		Burner controller	

Warranty Policy

What is covered

The Fogatti Standard Limited Warranty covers any defects in materials or workmanship when the product is installed and operated according to Fogatti written installation instructions, subject to the terms within this Limited Warranty document. This Limited Warranty applies only to products that are installed correctly in the United States and Canada. Improper installation may void this Limited Warranty. Fogatti strongly recommends that this tankless water heater be installed by a contractor who is licensed, state qualified, and trained on Fogatti's tankless products since improper installation may invalidate warranty coverage.

How long does coverage last

Item	Period of Coverage (from date of purchase)
	Residential Applications
All Other Parts and Components	12 months
*Shipping Costs	30 days

* Which excluding Alaska, Hawaii, and any location outside of the continental US and Canada

Limitation on warranties

During the Warranty Period, all repair parts must be genuine Fogatti parts; all repairs or replacements must be performed by a qualified professional who is professionally trained to do the type of repair. A component in the product fails because of a manufacturing defect, Fogatti will repair, replace, or refund the product to the owner at Fogatti's sole discretion and as determined to be appropriate by the Fogatti Support Team.

Fogatti does not authorize any person or company to assume for it any obligation or liability in connection with the replacement of the product. If Fogatti determines that repair of a product is not possible, Fogatti may replace the product with a comparable product at Fogatti's sole discretion. The warranty claim for product parts and labor may be denied if a component or product returned to Fogatti is found to be free of defects in material or workmanship; damaged by improper installation, use or operation; or damaged during return shipping.

No one is authorized to make any other warranties on behalf of Fogatti Corporation. Except as expressly provided herein, there are no other warranties, expressed or implied, including, but not limited to warranties of merchantability or fitness for a particular purpose, which extend beyond the description of the warranty herein. Any implied warranties of merchantability and fitness arising under state law are limited in duration to the period of coverage provided by this Limited Warranty, unless the period provided by state law is less. Some states do not allow limitations on how long an implied Limited Warranty lasts, so the above limitation may not apply to you. Fogatti shall not be liable for indirect, incidental, special, consequential, or other similar damages that may arise, including lost profits, damage to person or property, loss of use, inconvenience, or liability arising from improper installation, service, or use. Some states do not allow the exclusion or limitation of incidental or consequential damages, so the above limitation may not apply to you. This Limited Warranty gives you specific legal rights, and you may also have other rights which vary from state to state.

How to obtain service

To make a warranty claim through this Limited Warranty, the owner must contact Fogatti's Customer Service team at service@fogatti.com, schedule a call or live chat on the Fogatti Whatsapp. It is within Fogatti's sole discretion when a repair, replacement, or refund will be issued. Any return for refund must be approved by Fogatti's Customer Service team prior to shipping the product back to Fogatti. Please refer to Returning Your Product for Repair or Refund Policy provided with the Product.

Within the first 30 days of purchase, Fogatti will cover all ground shipping costs for warranty related issues in the US and Canada, excluding Alaska, Hawaii, and any location outside of the continental US and Canada. After the first 30 days of purchase, the owner is responsible for all shipping to Fogatti, regardless of reason or circumstance. Fogatti will cover the warranty related shipping costs when returning the product to the owner after repair/inspection. The method for warranty related shipping will be ground equivalent with the provider within Fogatti's sole discretion.

What information you will need for processing of your warranty claim:

- Proof of purchase
- Serial numbers
- Photos of the installation
- Photos of the damage part (if there is one)

All shipments of any type of product coming to Fogatti for any reason must have a Return Goods Authorization ("RGA") number for any repairs to be made. Please contact Fogatti to obtain an RGA number prior to shipping anything to Fogatti. Failure to do so could result in loss of product. Fogatti will not be responsible for replacement due to loss or damage if these steps are not properly followed.

Any returns to Fogatti must be sent in the original packaging. If your returned product does not have the original packaging and/or is missing any of the components that came with the product, there will be a nonnegotiable 15% restock fee.

What Is not covered

The following exclusions apply to this Limited Warranty:

1. A repair, replacement, or refund will not be provided under this Limited Warranty unless the Product containing the defective component is properly installed and maintained according to Fogatti's Installation Manual and Use & Care Manual and in compliance with all applicable federal, state/province, and local laws, regulations, codes, policies, and licensing requirements. Any abuse, misuse, alteration, neglect, or misapplication of the product will void this Limited Warranty.
2. A repair, replacement, or refund will not be provided if the product is damaged by services performed by third party service providers other than Fogatti Systems.
3. Fogatti systems is not responsible for any expenses arising from labor services, including but not limited to, installation or removal services due to a warranty claim.
4. A repair, replacement, or refund will not be provided if the product is damaged because of improper installation, including sizing, length, elevation, condensation drainage, or inadequate airflow.
5. A repair, replacement, or refund will not be provided if the product is damaged because of improper use, including freezing within the unit or surrounding piping, incorrect sizing for the application, scale build up, or incorrect gas and/or water pressure.
6. This product shall not be used as a pool or spa heater. Use of the Product as a pool or spa heater shall be considered misuse and will void this Limited Warranty.