

Make home your Havana

HOMVANA

Hybrid Ultrasonic Humidifier

User Manual / Model H111



Any questions? Email us or go live chat. We'll respond within 24h.

✉ support@homvana.shop

@homvanaofficial   

Contents

Safety Information	01
Getting to Know Your Humidifier	02
Package Contents	02
Specifications	03
Product Overview	03
Controls	04
Getting to Use Your Humidifier	07
Set up	07
Fill or Refill	08
Use Your Humidifier	09
(Optional) Use the Aroma Box	10
Cleaning & Maintenance	11
Troubleshooting	14
Problem	14
Error Code	17
Warranty	20

Safety Information

READ AND SAVE THESE SAFETY WARNINGS & INSTRUCTIONS

IMPORTANT: Please read, understand and comply with all of the instructions in this manual, or it may result in serious injury and/or damage to the product. If the humidifier is damaged or if it is not functioning properly, please contact us: ✉ support@homvana.shop

Before Use

- **ALWAYS** keep the humidifier out of reach from children.
- **ONLY** use this humidifier as described in this manual.
- **DO NOT** use this product in wet environments.
- **DO NOT** place the humidifier near sources of heat, such as stove tops, ovens, or radiators.
- **DO NOT** place the humidifier near any large pieces of furniture or in any high-traffic area where it can be easily knocked over.
- **ALWAYS** place the humidifier on a level surface before operation.
- **DO NOT** overfill the water tank.
- **DO NOT** plug in the unit with wet hands.
- **DO NOT** allow water or other liquids into the mist tube or air flue.

While Using

- **DO NOT** rotate or cover the nozzles while the humidifier is on.
- **DO NOT** attempt to inhale the mist directly from the nozzles.
- **DO NOT** shake the humidifier while using.
- **DO NOT** point the nozzle directly to the smoke alarm, or it may cause a wrong alarm.

Caution: Risk of Leaks and Electric Shock

DO NOT add essential oil, supplemental water treatment liquids, or third-party water filters into the water tank or base. This will damage the humidifier and cause leaks. **ONLY** add essential oil to the aroma pad.

After Use

- **ALWAYS** unplug the humidifier when not in use, or while cleaning it out.
- **DO NOT** clean the humidifier right after turning it off, especially after diffusing warm mist. Allow the humidifier to completely cool before cleaning.
- **DO NOT** immerse the humidifier base, power cord, or plug in water.
- **DO NOT** use detergents to clean the humidifier; **ONLY** use distilled white vinegar or citric acid.
- **DO NOT** place foreign objects into the unit's base or water tank.
- **DO NOT** use other items as replacement parts for this product.

Getting to Know Your Humidifier

Package Contents

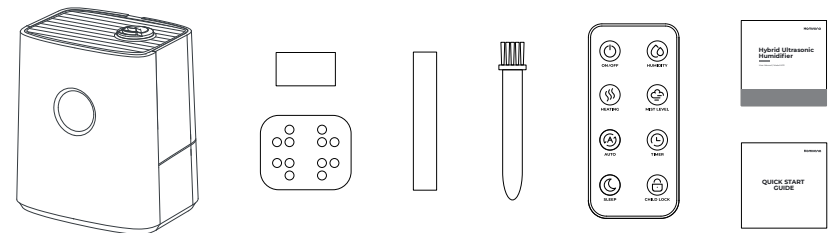

Homvana Hybrid Ultrasonic Humidifier H111 x 1
Aroma Pad x 3 (1 pre-installed)
Anti-scale Pad x 5 (1 pre-installed)
Remote Controller x 1

Cleaning Brush x 1
Sponge Filter x 4 (1 pre-installed)
Quick Start Guide x 1
User Manual x 1

Specifications

Model	H111
Input	AC 120V, 60Hz
Rated Power	280W
Water Tank Capacity	6.5L / 1.72Gal
Effective Range	430-861ft ² / 40-80m ²
Max Cool Mist Capacity	300mL/h
Max Warm Mist Capacity	700mL/h

Product Overview

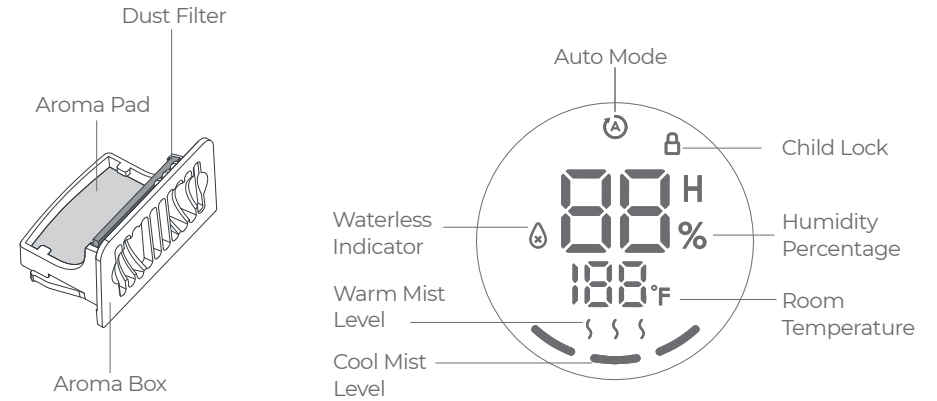
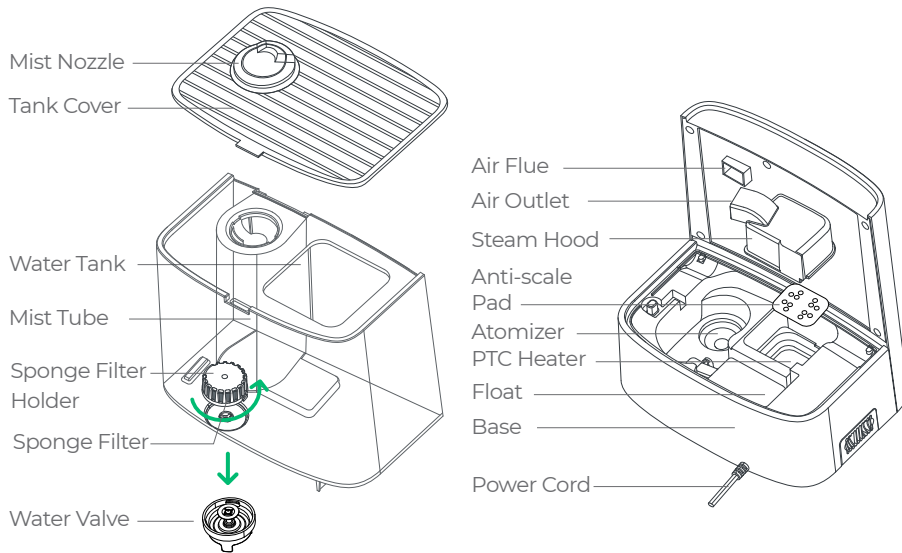

Controls

Note: The same controls can be found on the included remote controller.

On/Off Button



Tap to turn your humidifier on/off.

Mist Level Button



Tap repeatedly to change the cool mist levels: Medium, High and Low.

Note:

- Medium cool mist is the default setting when the humidifier is first turned on.
- The humidifier will remember the cool and warm mist levels that you previously set when turned off and left plugged in .



Heating Button

Tap repeatedly to change or turn on/off the warm mist levels: High, Off, Low, Medium.

Note:

- High warm mist is the default setting when the humidifier is first turned on.
- After turning on the warm mist, the humidifier may take 8-10 minutes to warm up and make a sound of boiling water. This sound fades away after a few minutes.

Caution:

The warm mist produced may be hot. DO NOT place your bare hands, face, or other exposed skin over the nozzles while using the warm mist function.



Auto Button

Tap to turn on/off Auto Mode. The humidifier will produce mist as needed to maintain a comfortable relative humidity (RH) percent of 60% by default.

Relative Humidity	Mist Level
<45% RH	High Cool & Warm Mist
45%-49% RH	Medium Cool & Warm Mist
50%-59% RH	Low Cool & Warm Mist
≥60% RH	Stop misting and enter standby

Note:

- Timer, Display Off or Child Lock can be used with Auto Mode.
- Tap the Auto Button, Sleep Button, Mist Level Button, Heating Button or Humidity Button to cancel the Auto Mode.



Humidity Button

Tap repeatedly to program the Relative Humidity (RH) percentage among 40% to 80% for the humidifier.

To confirm your selection, the humidity display will flash 3 times. To cancel your selection, press the Button for 2 seconds.

Note:

- The programmed humidity level can be added 5% humidity each time you press the Humidity Button.
- After setting the RH percentage, the display will alternate between the set RH percentage and the current humidity percentage.
- Once the environment RH reaches that preset, the humidifier will automatically stop misting and enter standby mode.
- After the humidifier enters standby mode, the display will alternate between the set RH percentage and the current humidity percentage. And it will start misting again when the humidity drops to 5% below the preset humidity.
- When the humidifier starts misting again after a while, it may take 8-10 minutes to warm up and make a sound of boiling water.



Timer Button

Tap repeatedly to set your desired timer among 1 to 12 hours. Once you stop tapping, the display will flash 3 times and the timer will start. To exit the timer function, tap repeatedly or press for 2 seconds until you hear a beep sound.

Note:

- When the timer starts, the display will alternate every 3 seconds between the remaining auto-off time and the current humidity percentage.
- Once selected your desired time, the humidifier will automatically turn off when the timer is finished counting down.



Sleep Button

Tap to turn on/off Sleep Mode.

When Sleep Mode starts, the LED display will turn off, the humidifier will continue to work as previously set, and no more beep sound for pressing other Buttons.

Press and hold for 2 seconds to turn off display.

Only equivalent to the screen-off function. The LED display will turn off; the humidifier will work as previously set.



Child Lock Button

Press and hold for 3 seconds to turn on/off Child Lock.

All the Buttons except Child Lock Button (including the On/Off Button) are invalid under Child Lock Mode.

Note: Tap once to enter the Child Lock when using the Remote Controller.

Getting to Use Your Humidifier

Set up

Place the humidifier on a level, elevated, and water-resistant surface, such as a table or nightstand. Make sure the room is well-ventilated.

Note:

- Position the humidifier at least 30-cm / 12-in away from walls and appliances to prevent them from getting wet.
- Direct the nozzles away from any furniture to prevent your furniture from getting wet.

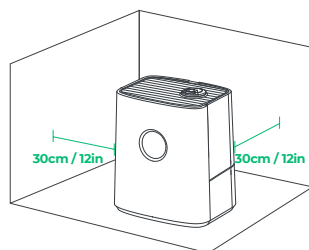

Fill or Refill

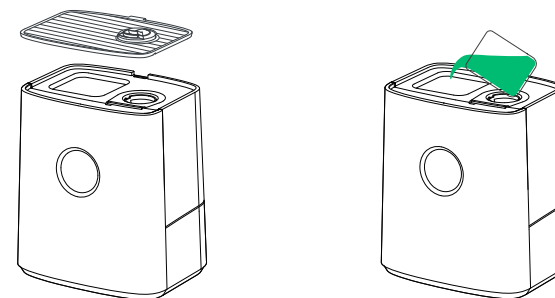

1. Remove the tank cover and fill the tank with room-temperature water.

Note:

- Purified or distilled water is recommended. Using tap water is also acceptable but may require frequent cleaning and maintenance if your tap water is hard.
- **DO NOT** overfill the water tank to it overflowing.

CAUTION

- **DO NOT** add water through the mist tube.
- **DO NOT** add water directly into the base chamber.
- **DO NOT** add essential oil into the humidifier.
- **ONLY** add essential oil to the aroma pad.

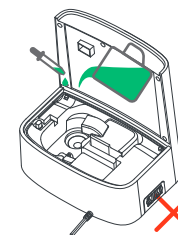
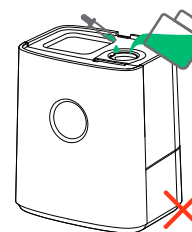

2. Replace the tank cover and place the water tank to the base.

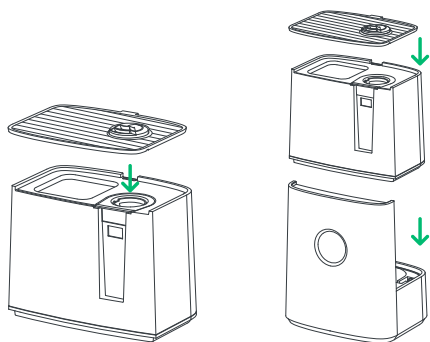

Use Your Humidifier

1. Plug in the humidifier. When connected to power, you will hear a beep sound and the humidifier will enter the standby mode.
2. Tap the On/Off Button to turn on the humidifier. The humidifier will start misting and its LED display will show the current humidity and temperature.

Note:

The combined medium cool mist and high warm mist is the default setting when the humidifier is turned on.

- Before connected to power, rotate the nozzles to adjust the direction of the mist.
- **DO NOT** rotate or cover the nozzles while the humidifier is on.
- **DO NOT** attempt to inhale the mist directly from the nozzles.
- If there is no water in the tank or the humidifier runs out of water, the machine will stop misting. Refill the tank (see *Fill or Refill*, page 7-8) and tap the On/Off Button to restart the humidifier.

3. Tap to select your desired mist levels or humidity levels.

To select your desired cool or warm mist level, tap repeatedly the Mist Level Button or the Heating Button.

To select your desired humidity levels, tap repeatedly the Humidity Button or tap the Auto Button to auto control the humidity level at a relative comfortable humidity of 60%. (see *Controls*, page 4-7)

Note:

- When your room has reached your preferred humidity level, tap the Misting Level Button or Heating Button to lower its cool or warm mist level, or just turn it off (see *Controls*, page 4-7).
 - The humidifier stops misting in Auto Mode if the humidity level is above 60% (see *Controls*, page 4-7).
4. Optionally, use the controls to set an auto-off timer, activate Sleep Mode or Child Lock, and more. (see *Controls*, page 4-7)
 5. Tap the On/Off Button to turn off the humidifier.

(OPTIONALLY) Use the Aroma Box

1. Turn off the humidifier and unplug it from the power outlet.
2. Pull out the aroma box at the bottom of the base.
3. Add 2-3 drops of essential oil on the aroma pad.
4. Replace the box into the humidifier.
5. Plug in and turn on the humidifier.

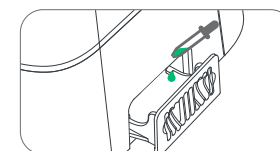
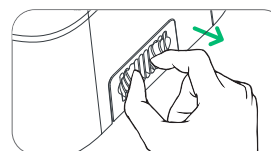

Note:

- **DO NOT** add essential oil, supplemental water treatment liquids, or third-party water filters into the water tank or base.
- **ONLY** add essential oil to the aroma pad.
- The aroma pad can be cleaned and reused after diffusing essential oil.

Cleaning & Maintenance

CAUTION:

- If the humidifier is not in use for over 2-3 months, it must be cleaned up before use, or the bad water quality might lead to inferior mist and malfunctions.
- Make sure the humidifier is unplugged from any power source before cleaning.
- The water in the base near the atomizer may still be warm after turning off the humidifier. Be cautious about using when pouring out the water.
- **DO NOT** touch the nozzles before the humidifier completely cools down.
- **DO NOT** rub the atomizer with hard or abrasive objects.
- Clean your humidifier at least once a week. Rinse out the water tank every time before you use it.
- **DO NOT** use detergents to clean the humidifier; **ONLY** use distilled white vinegar or citric acid.
- Purified or distilled water is recommended. Using tap water is also acceptable but may require frequent cleaning and maintenance if your tap water is hard.

Cleaning the Humidifier

1. Turn off the humidifier.
2. Drain the remaining water in the tank and the base.
3. Cleaning the humidifier and its parts.
4. Change a new one when the anti-scale pad has turned hard.

● Clean the base and tank cover

Please clean any water drops and dirt with a damp cloth then wipe them dry with a clean, dry cloth or tissues.

● Clean the water tank and water valve

Add water to the water tank and rinse it thoroughly. Use the included brush to gently wipe dirt (like scale on the bottom) that cannot be removed normally.

● Clean the steam hood and anti-scale pad

Remove the steam hood and anti-scale pad from the main unit and rinse them under clean, running water.

For stubborn scales, place the steam hood in a small container. Fill with citric acid and warm water (ratio 1: 20) to cover and soak it for 10-15 minutes. Wipe them gently with the included brush, and clean them with a damp cloth until any acid smell is completely gone.

Note: DO NOT forget to reinstall them on the main unit before operation, or it may cause malfunction.

● Clean the main unit, float, and atomizer

For dirt that is hard to be removed, fill the main unit with citric acid and warm water (The ratio is 1: 20) and soak for 10-15 minutes. Pour the liquid, then wipe and clean the main unit until any acid smell is completely gone.

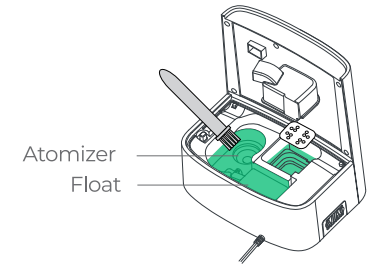

● Clean the sponge filter and holder

1. Rotate to remove the sponge filter holder.
2. Wipe the sponge filter holder with the included brush or a damp cloth, and rinse it until dirt has gone.

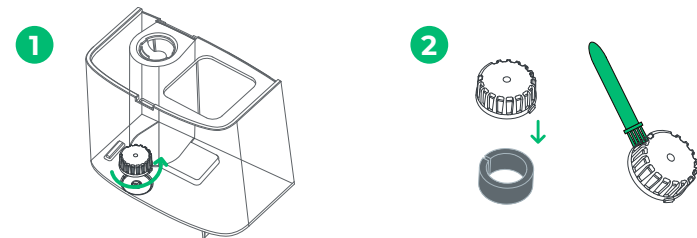

● Clean the aroma box

Pull out the the aroma box and rinse the aroma pad under warm, running water.

Note:

- **DO NOT** pour liquid detergents into the aroma pad.
- It is recommended to change the aroma pad **every 6 months**.

● Dry the main unit and other parts

Wipe them with dry cloth after cleaning and let them air dry in a cool indoor place.

Water remaining on the surface or inside the device may lead to smelly odors and mold.

Note:

- **DO NOT** submerge the base in water.
- **DO NOT** allow water inside the air flue or air outlet to prevent damage to the humidifier.

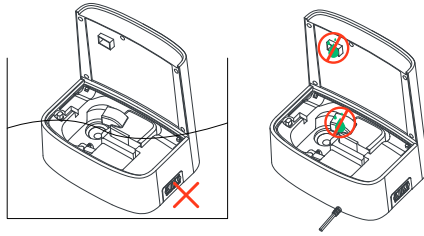

● Storage

Store the device in a dry place without direct sunlight.

Note: DO NOT store the device when it is not thoroughly dry. Doing so may cause bad odors and mold.

Maintenance

- Clean your humidifier at least **once a week** if you are using it on a regular basis to prevent any bacterial or mold growth.
- Always rinse out the water tank and change water before each use.
- It is recommended to use distilled water with the humidifier to prevent white residue around the area where your humidifier is being used.
- Clean and drain the humidifier before storage to prevent bacterial and mold growth.

Troubleshooting



Problem	Possible Solutions
The humidifier doesn't turn on, or stop misting unexpectedly.	Plug in the humidifier and turn it on.
	Add purified or distilled water to the water tank.
	Check to see if the humidifier is in Auto Mode. Depending on Auto Mode settings, the humidifier will automatically turn off when the humidity level is above the target level.
Display shows an incorrect humidity percentage.	The room may be larger than the humidifier's effective range. Move to a smaller room.
	Moisture may have built up inside the base of the humidifier. Turn off the humidifier and allow the base chamber to dry.
Little or no mist comes out.	Turn the mist level to a higher setting.
	Fill the water tank.
	There may be too much water in the base chamber. Empty the base chamber. Refill the water tank and place it properly onto the base.
	Make sure the humidifier is not set on carpet or other surfaces that may block air flow.
	Make sure the nozzles are not blocked or clogged.
	Make sure the humidifier is on a level surface.
	While the room or water temperature is too low, a low mist level is expected. Turn the mist level to the highest setting and let the humidifier run for a while, then adjust to the desired setting.
	If the water tank or base was washed with detergent, rinse thoroughly with clean water to remove any detergent.
	Make sure no oil is sticking to the PTC heater, atomizer, or bottom of the water tank. If so, please clean it up.

Problem	Possible Solutions
Humidifier uses water too quickly.	The humidifier uses up water based on the environmental temperature and humidity. If your environment is cold and/or dry, the humidifier will run out of water faster.
Humidifier produces an unusual smell.	If the humidifier is new, unplug and rinse its detachable parts, then place in a cool, dry place for 12 hours.
	If essential oil was added on the aroma pad, rinse the pad under clean water and allow it to dry.
	Clean the water tank and base chamber (see <i>Cleaning & Maintenance</i> , page 10-13).
Mold grows inside the humidifier.	Clean the water tank and base chamber regularly (see <i>Cleaning & Maintenance</i> , page 10-13).
Essential oil has little or no smell.	Add more drops of essential oil. For best results, use pure essential oil.
Humidifier makes a loud or unusual noise.	Make sure the water tank is properly in place (see <i>Fill or Refill</i> , page 7-8)
	Set mist level to a lower setting.
	Empty the base chamber. Refill the water tank and place the water tank properly onto the base.
	The humidifier may be malfunctioning. Stop using the humidifier and contact us: ✉ support@homvana.shop
White dust appears around the humidifier.	We recommend using purified or distilled water to fill the humidifier. Avoid using water with high mineral content.
	Clean the humidifier (see <i>Cleaning & Maintenance</i> , page 10-13).

Water leaks from the humidifier.	Make sure the water valve is securely placed.
	Avoid running the humidifier in a room with over 60% relative humidity.
	Wipe any excess water off the top and bottom of the base.
	DO NOT shake the humidifier.
	Make sure to place the humidifier on a flat, level surface.
	Check the water tank for leaks. If there are leaks, contact us: ✉ support@homvana.shop
Condensation forms around humidifier or windows.	Unscrew the water valve and clean it (see <i>Cleaning & Maintenance</i> , page 10-13). Put the water valve back before restarting your humidifier.
	Humidity may be too high. Turn down the mist level, turn off the humidifier, or open a door or window to the room.

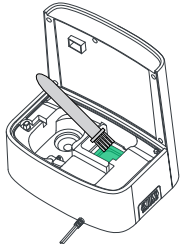
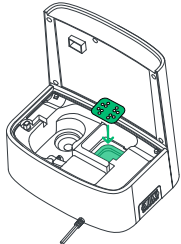
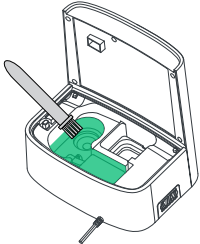
If your problem is not listed, please contact us: [✉ support@homvana.shop](mailto:support@homvana.shop)

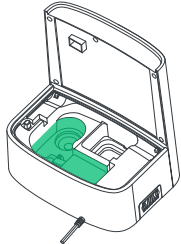
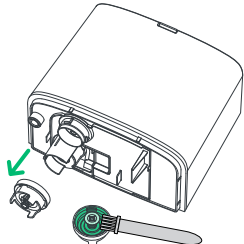
Error Code	Possible Solutions	Figure
01	Clean the scale on the PTC heater.(see <i>Cleaning & Maintenance</i> , page10-13).	
	Change the anti-scale pad.	
02	Clean the scale on the inner side of the base chamber.	

Error Code	Possible Solutions	Figure
03	Pour out some water in the base chamber.	
	Unscrew the water valve and clean it. Put the water valve back before restarting your humidifier. If the humidifier still can't work, please contact us: ✉ support@homvana.shop	
04	The humidifier is malfunctioning. Please contact us: ✉ support@homvana.shop	

If your problem is not listed, please contact us: ✉ support@homvana.shop

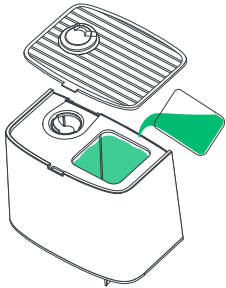
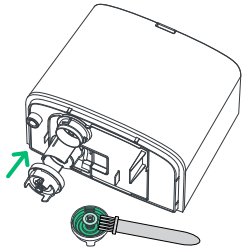
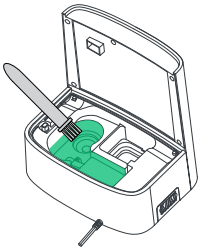
Error Code	Possible Solutions	Figure
	Fill the water tank.	
05	Unscrew the water valve and clean it (see <i>Cleaning & Maintenance, page 10-13</i>). Put the water valve back before restarting your humidifier.	
	Clean the scale on the inner side of the base chamber (see <i>Cleaning & Maintenance, page 10-13</i>). If the humidifier still can't work, Please contact us: ✉ support@homvana.shop	

Error Code	Possible Solutions	Figure
06	The humidifier is malfunctioning. Please contact us: ✉ support@homvana.shop	

If your problem is not listed, please contact us: **✉ support@homvana.shop**

WARRANTY

Thank you for choosing Homvana Hybrid Ultrasonic Humidifier. At Homvana, we use only the highest-quality materials, giving us the confidence to provide you with:

- ✔ **30-day money-back guarantee**
- ✔ **Industry-leading 3-year warranty**
- ✔ **Lifetime technical support**

Whatever you need, we're here to help. Just get in touch with us at:

✉ support@homvana.shop

@homvanaofficial   

Each item is 100% inspected before despatch. It's normal sometimes to find water mist or beads left from pre-shipment testing. Beware of damage from dropping. Don't hesitate to contact us if you receive broken items or missing accessories. You will get timely assistance, replacement or refund. We promise to make things right with our wholehearted service.