

WEIDER®

PLATINUM

STANDARD BENCH

weiderfitness.com

Model No. WEBE60020.0

Serial No. _____

Write the serial number in the space above for reference.

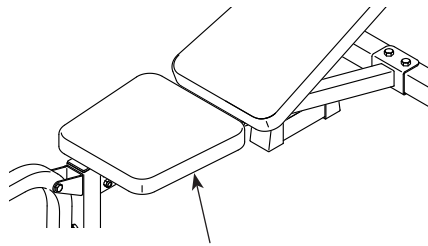

Serial Number Decal (under seat)

ACTIVATE YOUR WARRANTY

To register your product and activate your warranty today, go to my.weiderfitness.com.

CUSTOMER CARE

For service at any time, go to support.weiderfitness.com.

Or call 1-877-992-5999
Mon.–Fri. 6 a.m.–6 p.m. MT
Sat. 8 a.m.–12 p.m. MT

Please do not contact the store.

⚠ CAUTION

Read all precautions and instructions in this manual before using this equipment. Keep this manual for future reference.

USER'S MANUAL

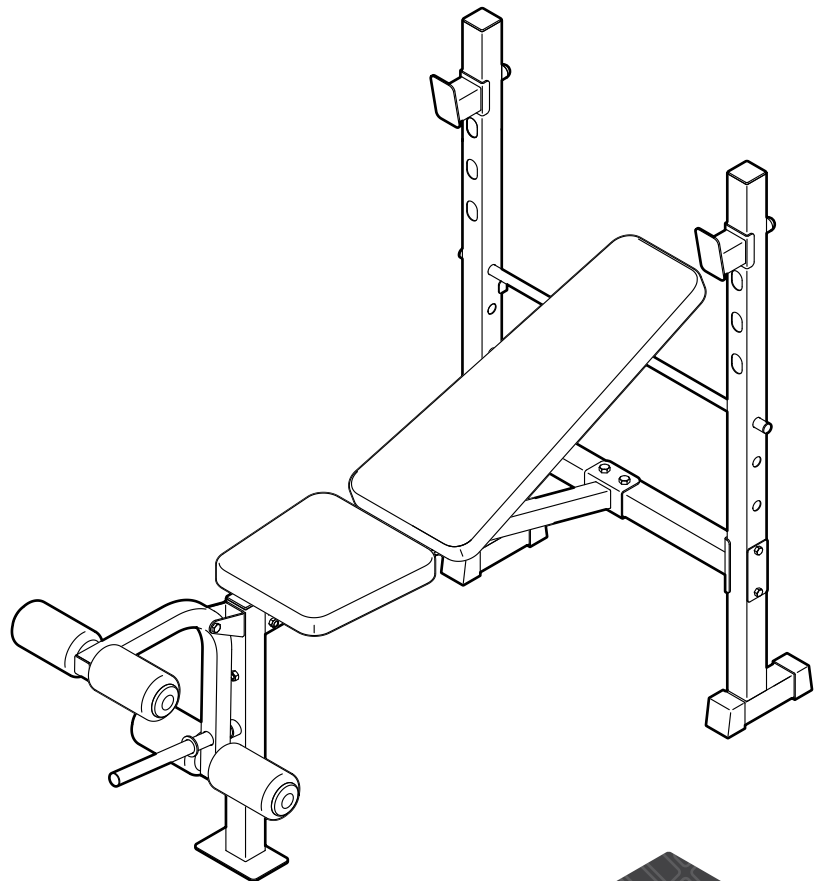
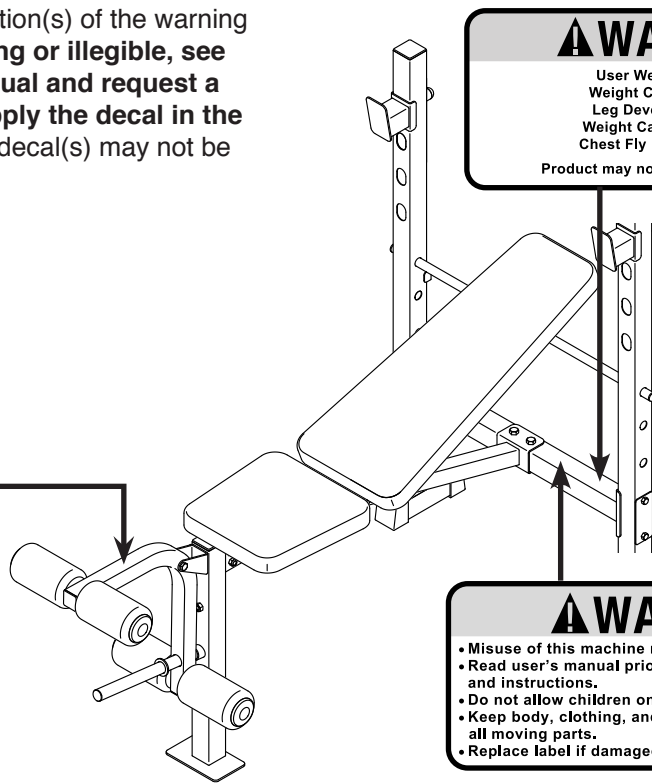

TABLE OF CONTENTS

WARNING DECAL PLACEMENT	2
IMPORTANT PRECAUTIONS.....	3
BEFORE YOU BEGIN.....	5
PART IDENTIFICATION CHART.....	6
ASSEMBLY.....	7
ADJUSTMENT	12
EXERCISE GUIDELINES.....	14
PART LIST.....	18
EXPLODED DRAWING.....	19
ORDERING REPLACEMENT PARTS	Back Cover
LIMITED WARRANTY.....	Back Cover

WARNING DECAL PLACEMENT

This drawing shows the location(s) of the warning decal(s). **If a decal is missing or illegible, see the front cover of this manual and request a free replacement decal. Apply the decal in the location shown.** Note: The decal(s) may not be shown at actual size.



IMPORTANT PRECAUTIONS

⚠ WARNING: To reduce the risk of serious injury, read all important precautions and instructions in this manual and all warnings on the weight bench before the your weight bench. ICON assumes no responsibility for personal injury or property damage sustained by or through the use of this product.

1. It is the responsibility of the owner to ensure that all users of the weight bench are adequately informed of all precautions.
2. Before beginning any exercise program, consult your physician. This is especially important for persons over age 35 or persons with pre-existing health problems.
3. The weight bench is not intended for use by persons with reduced physical, sensory, or mental capabilities or lack of experience and knowledge, unless they are given supervision or instruction about use of the weight bench by someone responsible for their safety.
4. The weight bench is intended for home use only. Do not use the weight bench in any commercial, rental, or institutional setting.
5. Keep the weight bench indoors, away from moisture and dust. Do not put the weight bench in a garage or covered patio, or near water.
6. Place the weight bench on a level surface, with a mat beneath it to protect the floor or carpet. Make sure that there is enough clearance around the weight bench to mount, dismount, and use the weight bench.
7. Keep children under age 16 and pets away from the weight bench at all times.
8. Inspect and properly tighten all parts each time the weight bench is used. Replace any worn parts immediately.
9. Keep hands and feet away from moving parts.
10. Always wear athletic shoes for foot protection while using the weight bench.
11. Do not use a barbell that is longer than 6 ft. (1.8 m) with the weight bench. Note: The weight bench does not include a barbell or weights.
12. The weight bench is designed to support a maximum user weight of 300 lbs. (136 kg) and a maximum total weight of 410 lbs. (186 kg). Do not place more than 110 lbs. (50 kg), including a barbell and weights, on the weight rests. Do not place more than 50 lbs. (23 kg) on the leg lever.
13. Always place the same amount of weight on both ends of your barbell while you are using it. Always keep some weight on both ends of the barbell while adding or removing weights to prevent the barbell from tipping.
14. When you are using the leg lever, place a barbell with the same amount of weight on the weight rests to balance the weight bench.
15. Always exercise with a partner. When you are performing bench press exercises, your partner should stand behind you to catch the barbell if you cannot complete a repetition.
16. When using the backrest in the level position or an inclined position, make sure that the backrest support is inserted completely through both uprights, and that the backrest support is turned to the locked position.
17. Over exercising may result in serious injury or death. If you feel faint, if you become short of breath, or if you experience pain while exercising, stop immediately and cool down.

PROTECT

YOUR FITNESS EQUIPMENT
WITH AN EXTENDED SERVICE PLAN



Your new fitness equipment is not an ordinary purchase; it is an investment in your health and well being for years to come.

As the leading provider of manufacturer's extended service plans, ICON strives to protect your equipment and your future.

Please review the following service plans and find one that best fits your needs.

PREVENTIVE MAINTENANCE SERVICE PLANS

Equipment Price	3-Year Plan	5-Year Plan
\$0.00 to \$1000.00	\$199.99	\$289.99
\$1001.00 to \$1500.00	\$259.99	\$379.99
\$1501.00 to \$2500.00	\$339.99	\$489.99
(Bikes/Systems Only) \$0.00 to \$2500.00	\$139.99	NA

Features:

- Includes an annual preventive maintenance and performance check at your convenience
- Unlimited in-home repairs; no shipping required
- Covers parts and labor on all manufacturer's defects, as well as wear and tear on parts
- Up to 5 years of coverage available

STANDARD SERVICE PLANS

Equipment Price	1-Year Plan	2-Year Plan	3-Year Plan
\$0.00 to \$300.00	\$29.99	\$39.99	\$59.99
\$301.00 to \$1000.00	\$89.99	\$119.99	\$149.99
\$1001.00 to \$2000.00	\$109.99	\$139.99	\$179.99
\$2001.00 to \$3000.00	\$179.99	\$209.99	\$239.99

Features:

- Unlimited in-home repairs; no shipping required
- Covers parts and labor on all manufacturer's defects, as well as wear and tear on parts
- Up to 3 years of coverage available

To protect your fitness equipment today, please
call Customer Care at **1-800-677-3838.**
Or, visit us online at **www.utserv.com.**



BEFORE YOU BEGIN

Thank you for selecting the new WEIDER® PLATINUM STANDARD BENCH weight bench. The weight bench offers a selection of exercises designed to develop the major muscle groups of the body. Whether your goal is to tone your body, build dramatic muscle size and strength, or improve your cardiovascular system, the weight bench will help you to achieve the specific results you want.

For your benefit, read this manual carefully before using the weight bench. If you have questions after

reading this manual, please see the front cover of this manual. To help us assist you, note the product model number and serial number before contacting us. The model number and the location of the serial number decal are shown on the front cover of this manual.

Before reading further, please look at the drawing below and familiarize yourself with the parts that are labeled.

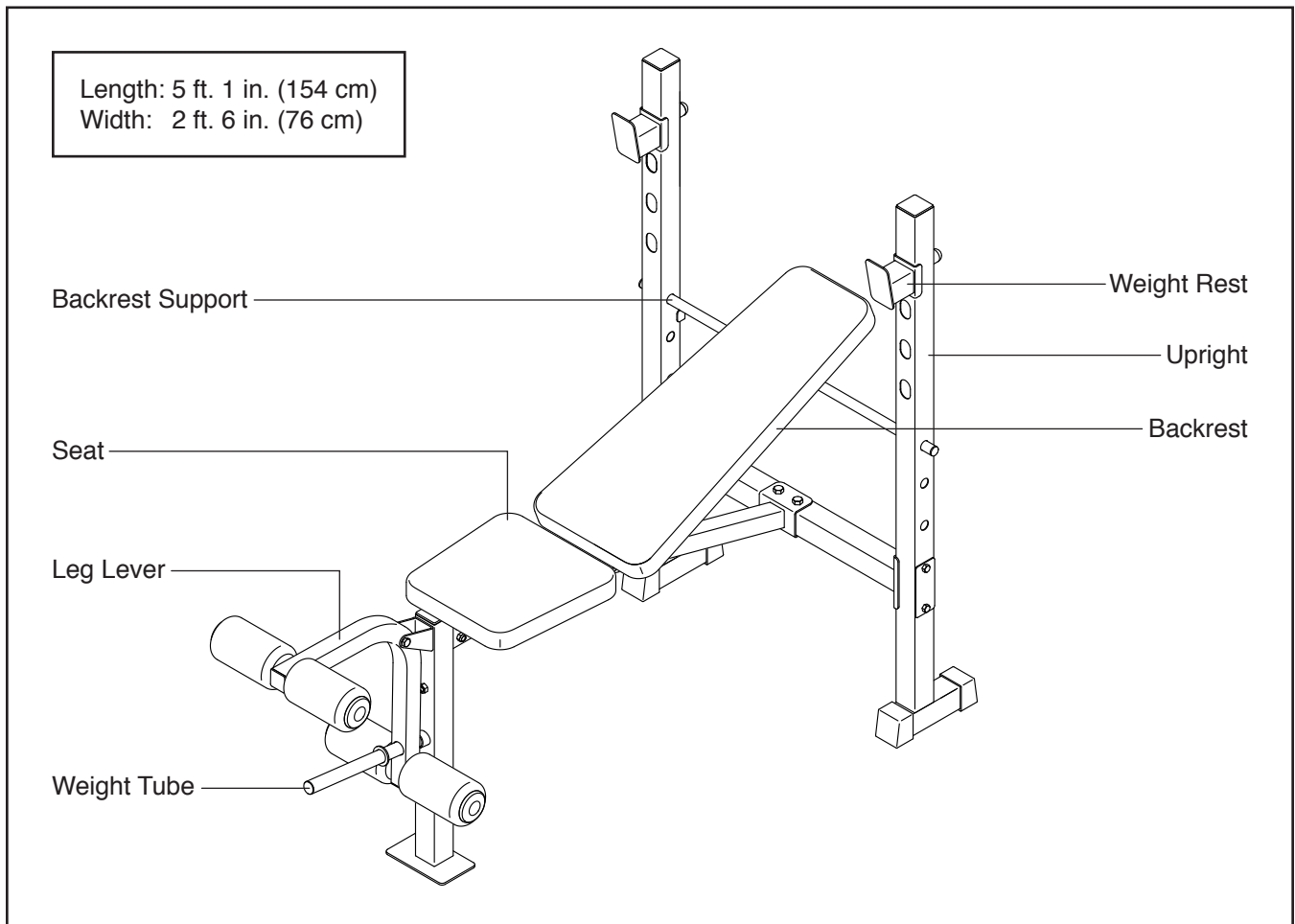

PART IDENTIFICATION CHART

Use the drawings below to identify small parts used in assembly. The number in parentheses by each drawing is the key number of the part, from the PART LIST near the end of this manual. **IMPORTANT: If you cannot find a part in the hardware kit, check to see whether it has been preassembled. Extra hardware may be included.**

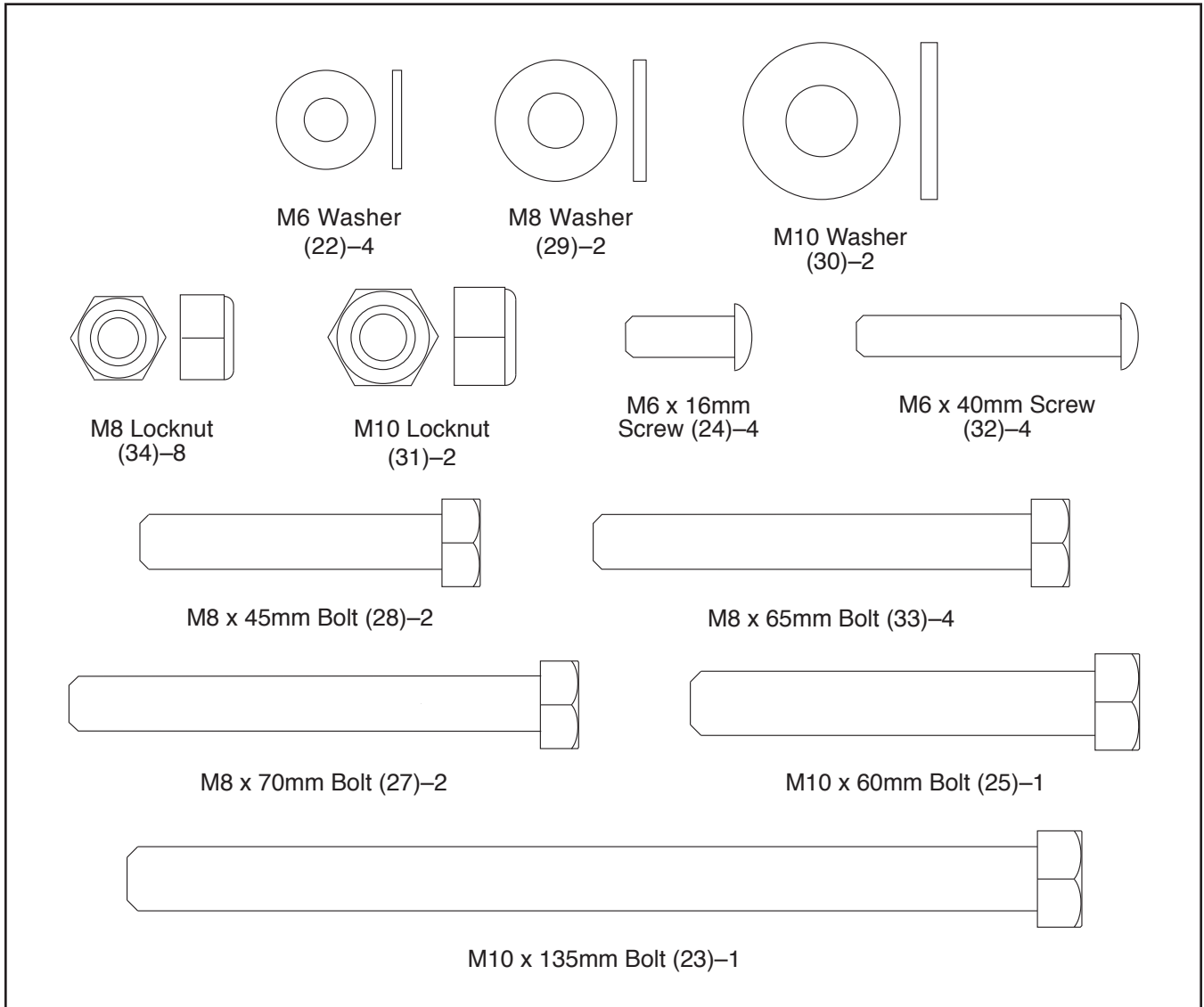

ASSEMBLY

- To hire an authorized service technician to assemble this product, call 1-800-445-2480.
- Assembly requires two persons.
- Because of its weight and size, assemble the weight bench in the location where it will be used. Make sure that there is enough clearance to walk around the weight bench as you assemble it.
- Place all parts in a cleared area and remove the packing materials. Do not dispose of the packing materials until you complete all assembly steps.
- To identify small parts, see page 6.

- In addition to the included tool(s), assembly requires the following tools:

two adjustable wrenches



one rubber mallet

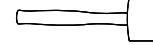

one standard screwdriver



one Phillips screwdriver

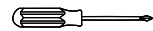

Assembly may be easier if you have a set of wrenches. To avoid damaging parts, do not use power tools.

1. **Go to my.weiderfitness.com on your computer and register your product.**

- documents your ownership
- activates your warranty
- ensures priority customer support if assistance is ever needed

Note: If you do not have internet access, call Customer Care (see the front cover of this manual) and register your product.

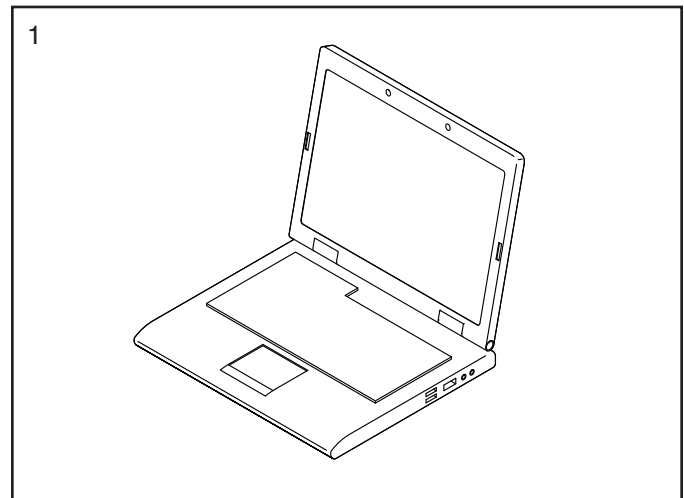

2. Orient the two Uprights (1) as shown.

Next, orient the Crossbar (2) so that the warning decals (A) are in the position shown.

Attach the Crossbar (2) to one of the Uprights (1) with two M8 x 65mm Bolts (33), an Upright Plate (35), and two M8 Locknuts (34); **do not fully tighten the Locknuts yet.**

Attach the Crossbar (2) to the other Upright (1) in the same way.

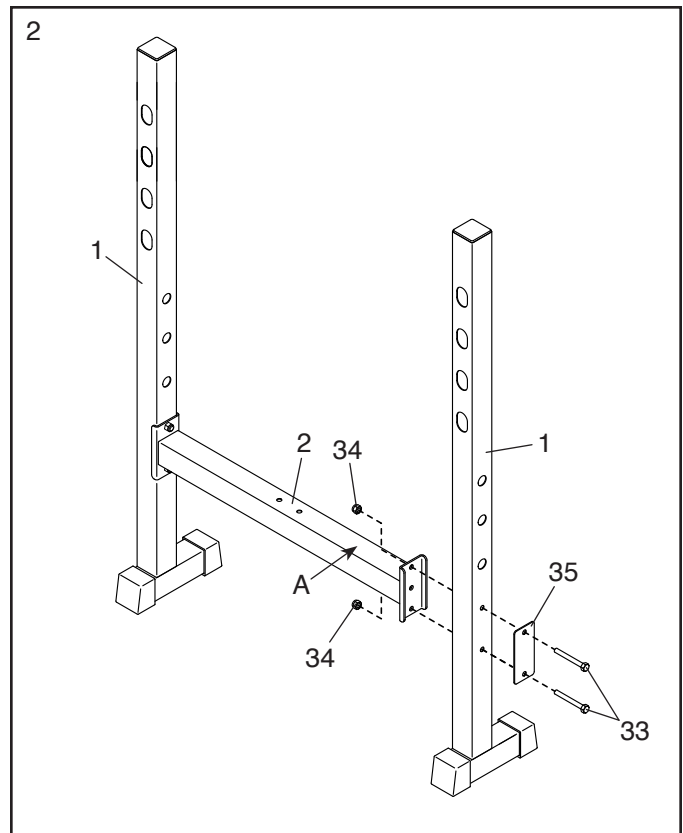

3. Attach the Front Leg (4) to the Frame (3) with two M8 x 45mm Bolts (28), two M8 Washers (29), and two M8 Locknuts (34). **Make sure that the Locknuts are in the indicated hexagonal holes (B); do not tighten the Bolts yet.**

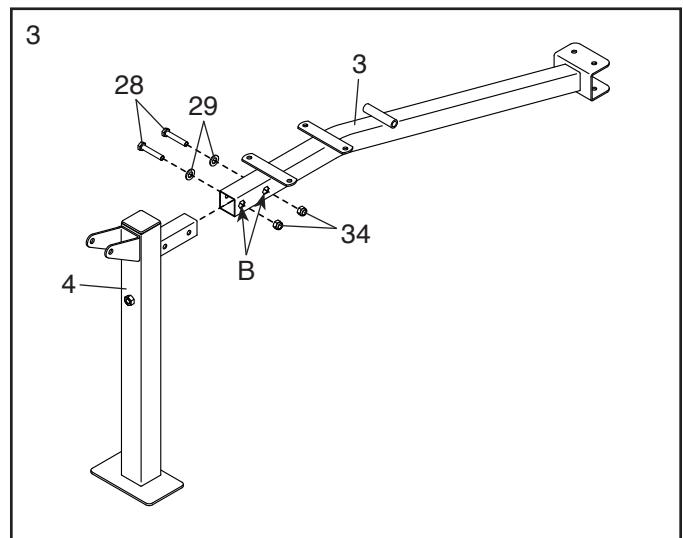

4. Attach the Frame (3) to the Crossbar (2) with two M8 x 70mm Bolts (27) and two M8 Locknuts (34); **do not fully tighten the Locknuts yet.**

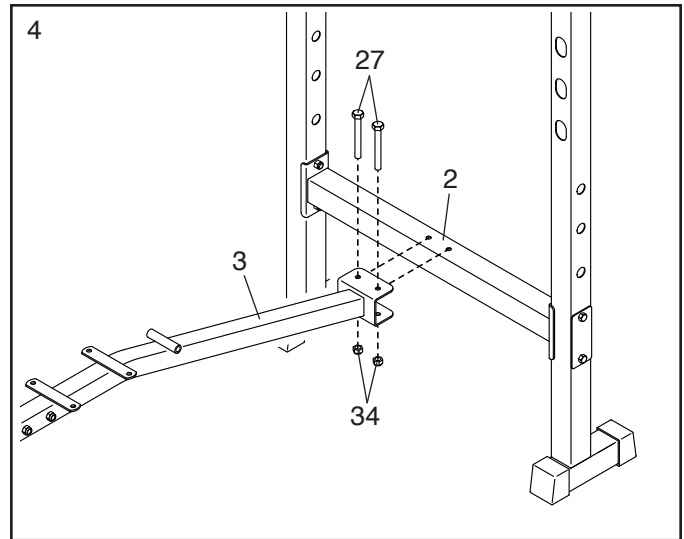

5. Insert the Backrest Support (14) into one of the three sets of holes in the Uprights (1).

See the inset drawing. Rotate the Backrest Support (14) so that the clip (C) is wrapped around an Upright (1) as shown.

See steps 2–4. Tighten the M8 Locknuts (34) and the M8 x 45mm Bolts (28) used in these steps.

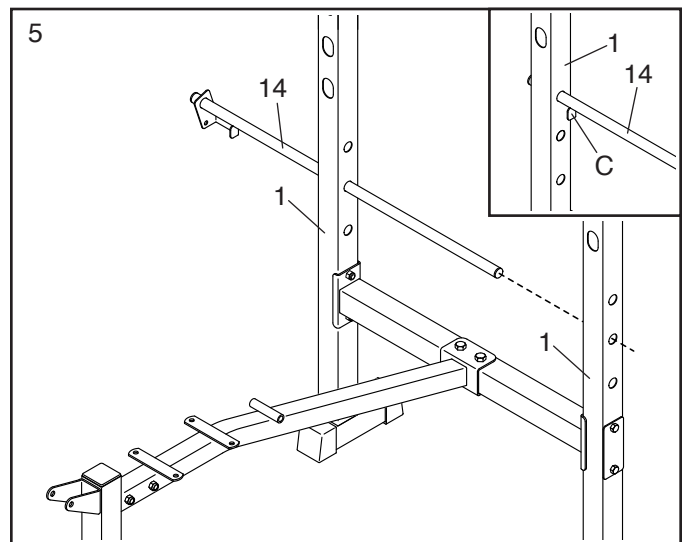

6. Using a small plastic bag to keep your fingers clean, apply some of the included grease to an M10 x 60mm Bolt (25).

Attach the Leg Lever (6) to the Front Leg (4) with the M10 x 60mm Bolt (25) and an M10 Locknut (31). **Do not overtighten the Locknut; the Leg Lever must pivot easily.**

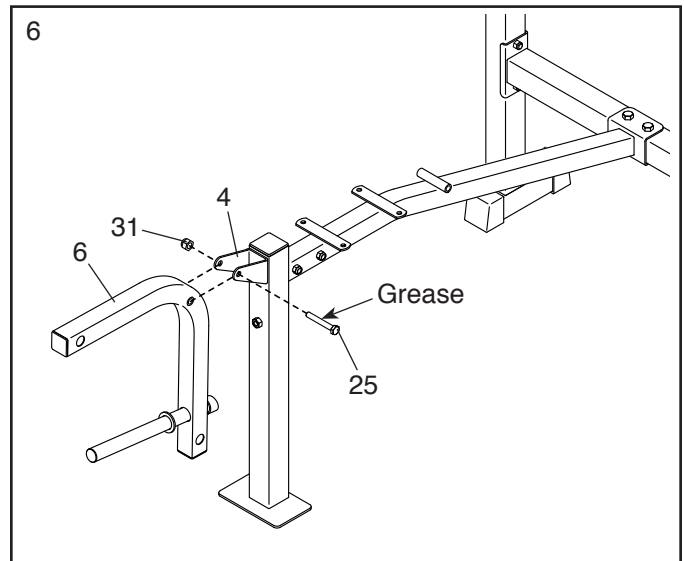

7. Insert a Pad Tube (12) through the Leg Lever (6). Then, slide a Foam Pad (13) onto each side of the Pad Tube, and press a Pad Cap (5) into each end of the Pad Tube.

Repeat this step with the other Pad Tube (12), Foam Pads (13), and Pad Caps (5).

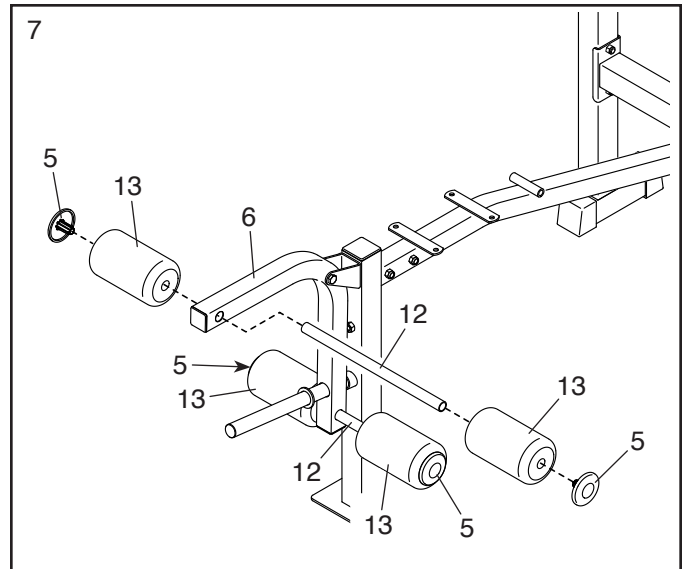

8. Orient the Backrest (8) as shown.

Next, orient the Backrest Tubes (7) so that the indicated holes (D) are in the position shown.

Attach the Backrest Tubes (7) to the Backrest (8) with four M6 x 40mm Screws (32) and four M6 Washers (22); **do not tighten the Screws yet.**

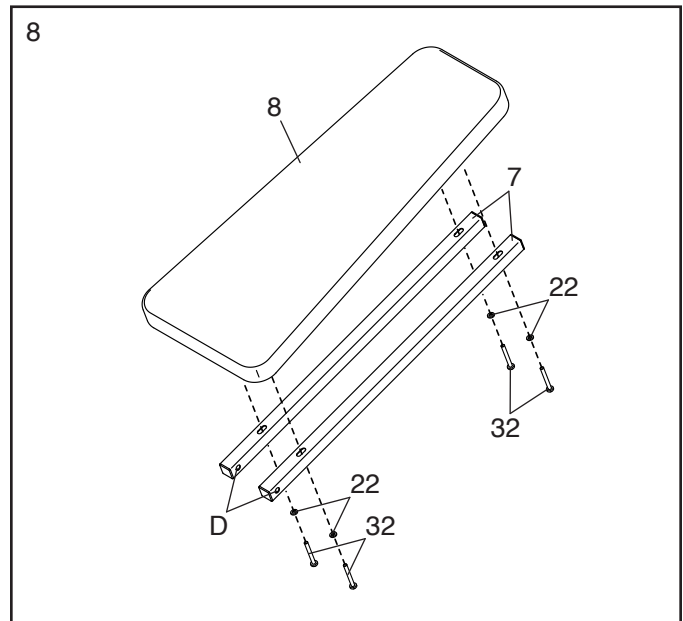

9. Apply grease to an M10 x 135mm Bolt (23).

Attach the Backrest Tubes (7) to the Frame (3) with the M10 x 135mm Bolt (23), two M10 Washers (30), and an M10 Locknut (31). **Do not overtighten the Locknut; the Backrest Tubes must pivot easily.**

See step 8. Tighten the M6 x 40mm Screws (32).

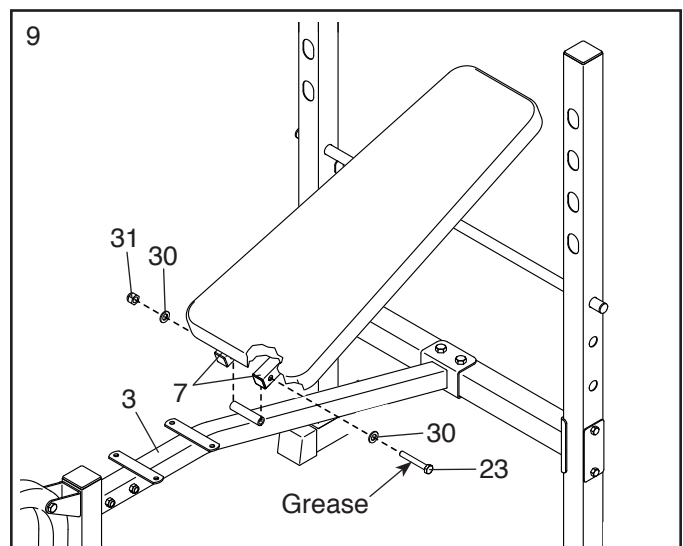

10. Orient the Seat (9) as shown.

Attach the Seat (9) to the Frame (3) with four M6 x 16mm Screws (24); **start all the Screws, and then tighten them.**

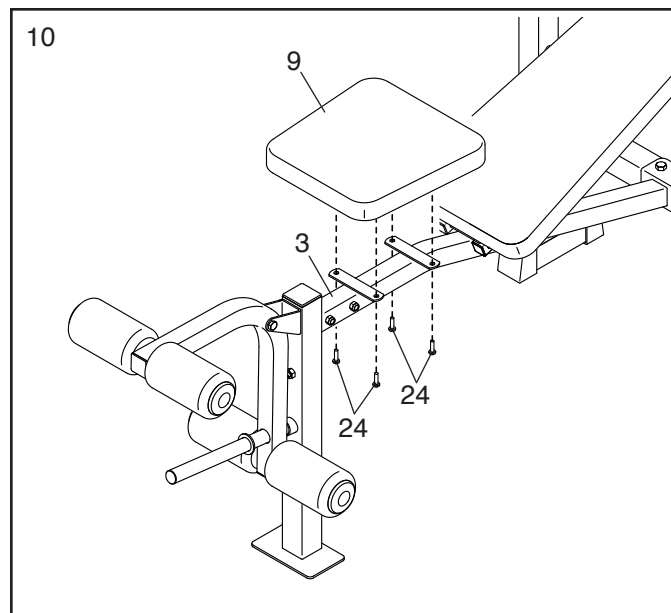

11. Fully insert a Weight Rest (15) into an Upright (1).

Repeat this step with the other Weight Rest (15). Make sure that the Weight Rests are at the same height.

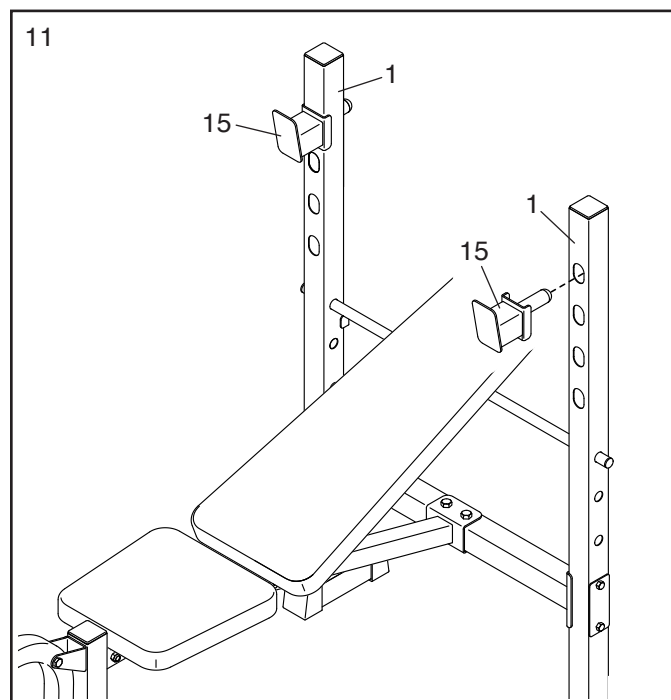

12. **Make sure that all parts are properly tightened before you use the weight bench.** The use of all remaining parts will be explained in ADJUSTMENT, beginning on page 12.

ADJUSTMENT

The weight bench is designed to be used with your own weight set (not included). This section explains how to adjust the weight bench. See EXERCISE GUIDELINES on page 14 for important exercise information, and refer to the accompanying exercise guide to see the correct form for several exercises. Refer also to the exercise information accompanying your weight set for additional exercises.

Make sure that all parts are properly tightened each time the weight bench is used. Replace any worn parts immediately. The weight bench can be cleaned with a damp cloth and a mild, non-abrasive detergent; **do not use solvents.**

ADJUSTING THE BACKREST

The Backrest (8) can be used in a declined position, a level position, or either of two inclined positions. To use the Backrest in the declined position, remove the Backrest Support (14) and lay the Backrest on the Crossbar (2).

To use the Backrest (8) in the level position or an inclined position, lift the Backrest and insert the Backrest Support (14) through one of the sets of holes in the Uprights (1). **Rotate the Backrest Support** so that the clip (A) is wrapped around an Upright as shown.

⚠ WARNING: When using the Backrest (8) in a level position or an inclined position, insert the Backrest Support (14) completely into both Uprights (1) and rotate it so that the clip (A) is wrapped around an Upright.

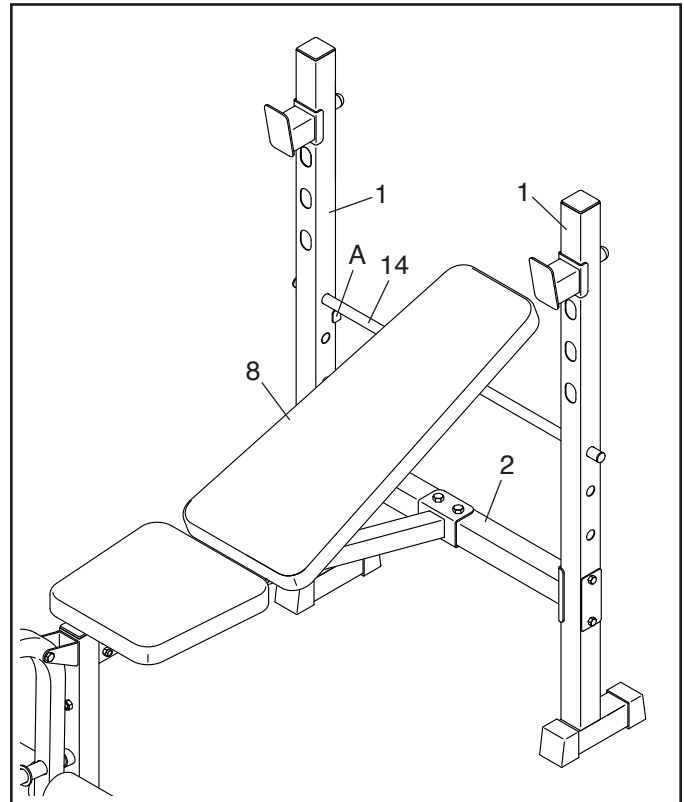

ATTACHING WEIGHTS TO THE LEG LEVER

To use the Leg Lever (6), slide the desired weights (B) (not included) onto the weight tube (C). Secure the weights with the Spring Clip (10).

⚠ WARNING: Do not place more than 50 lbs. (23 kg) on the Leg Lever (6). When using the Leg Lever, place a barbell with the same amount of weight on the Weight Rests (not shown) to balance the weight bench.

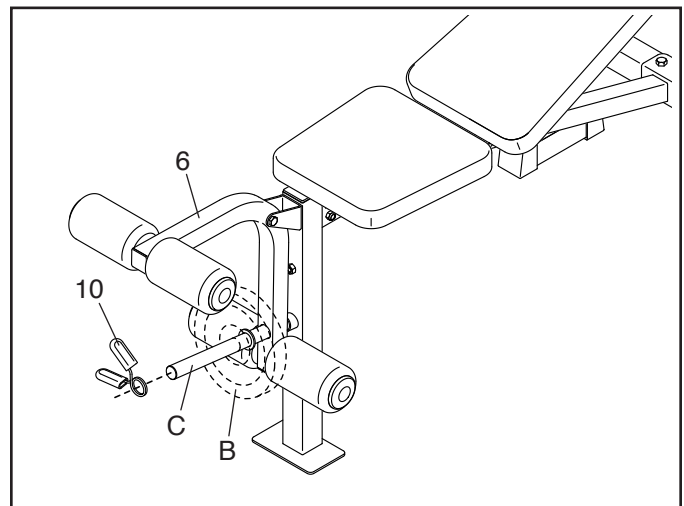

ADJUSTING THE WEIGHT RESTS

To change the height of the Weight Rests (15), remove them from the Uprights (1) and fully insert them into a different set of holes in the Uprights.

⚠ WARNING: Always set both Weight Rests (15) at the same height.

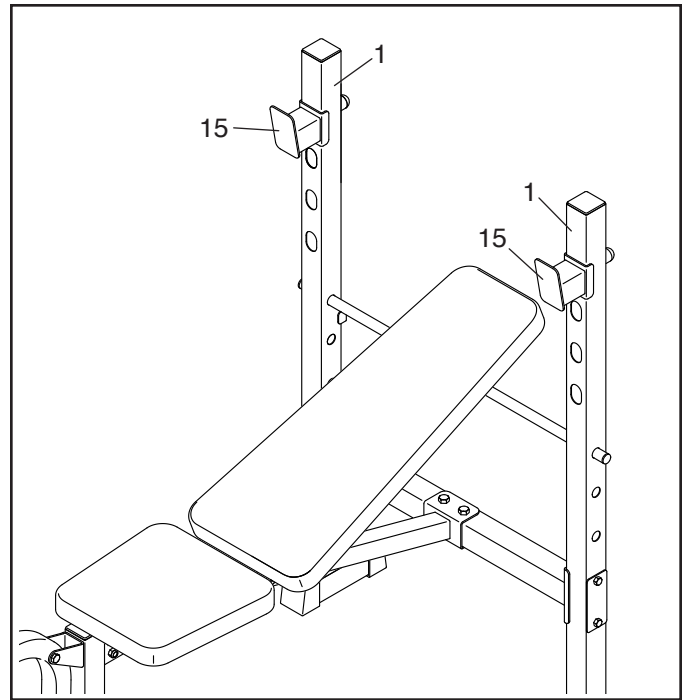

EXERCISE GUIDELINES

FOUR TYPES OF STRENGTH WORKOUTS

Note: A “repetition” is one complete cycle of an exercise, such as one sit-up. A “set” is a series of repetitions.

Muscle Building—Work your muscles near their maximum capacity and progressively increase the intensity of your exercise. Adjust the intensity level of an individual exercise as follows:

- Change the amount of resistance used.
- Change the number of repetitions or sets performed.

Use your own judgment to determine the amount of resistance that is right for you. Begin with 3 sets of 8 repetitions for each exercise you perform. Rest for 3 minutes after each set. When you can complete 3 sets of 12 repetitions without difficulty, increase the amount of resistance.

Toning—Tone your muscles by working them to a moderate percentage of their capacity. Select a moderate amount of resistance and increase the number of repetitions in each set. Complete as many sets of 15 to 20 repetitions as possible without discomfort. Rest for 1 minute after each set. Work your muscles by completing more sets rather than by using high amounts of resistance.

Weight Loss—To lose weight, use a low amount of resistance and increase the number of repetitions in each set. Exercise for 20 to 30 minutes, resting for a maximum of 30 seconds between sets.

Cross Training—Combine strength training and aerobic exercise by following this type of program:

- Strength workouts on Monday, Wednesday, and Friday.
- 20 to 30 minutes of aerobic exercise on Tuesday and Thursday.
- One full day of rest each week to give your body time to regenerate.

WORKOUT GUIDELINES

Familiarize yourself with the equipment and learn the proper form for each exercise. Use your own judgment to determine the appropriate length of time for each

workout, and the numbers of repetitions and sets to complete. Progress at your own pace and be sensitive to your body’s signals. Follow each strength workout with at least one day of rest.

Warming Up—Start with 5 to 10 minutes of stretching and light exercise. A warm-up increases your body temperature, heart rate, and circulation in preparation for exercise.

Working Out—Include 6 to 10 different exercises in each workout. Select exercises for every major muscle group, emphasizing areas that you want to develop. To give balance and variety to your workouts, vary the exercises from workout to workout.

Cooling Down—Finish with 5 to 10 minutes of stretching. Stretching increases the flexibility of your muscles and helps to prevent post-exercise problems.

EXERCISE FORM

Move through the full range of motion for each exercise and move only the appropriate parts of the body. Perform the repetitions in each set smoothly and without pausing. The exertion stage of each repetition should last about half as long as the return stage. Exhale during the exertion stage of each repetition and inhale during the return stroke. Never hold your breath.

Rest for a short period of time after each set:

- Muscle Building—Rest for three minutes after each set.
- Toning—Rest for one minute after each set.
- Weight Loss—Rest for 30 seconds after each set.

STAYING MOTIVATED

For motivation, keep a record of each workout. Write the date, the exercises performed, the resistance used, and the numbers of sets and repetitions completed. Record your weight and key body measurements once a month. To achieve good results, make exercise a regular and enjoyable part of your life.

EXERCISE LOG

Make copies of this page, and use the copies to schedule and record your strength and aerobic workouts. Scheduling and recording your workouts will help you to make exercise a regular and enjoyable part of your life.

Strength

Date:

____ / ____ / ____

Exercise	Lbs.	Sets	Reps	Exercise	Lbs.	Sets	Reps
1.				6.			
2.				7.			
3.				8.			
4.				9.			
5.				10.			

Aerobic

Date:

____ / ____ / ____

Exercise	Time	Distance	Speed

Strength

Date:

____ / ____ / ____

Exercise	Lbs.	Sets	Reps	Exercise	Lbs.	Sets	Reps
1.				6.			
2.				7.			
3.				8.			
4.				9.			
5.				10.			

Aerobic

Date:

____ / ____ / ____

Exercise	Time	Distance	Speed

Strength

Date:

____ / ____ / ____

Exercise	Lbs.	Sets	Reps	Exercise	Lbs.	Sets	Reps
1.				6.			
2.				7.			
3.				8.			
4.				9.			
5.				10.			

Aerobic

Date:

____ / ____ / ____

Exercise	Time	Distance	Speed

NOTES

NOTES

PART LIST

Model No. WEBE60020.0 R0820A

Key No.	Qty.	Description	Key No.	Qty.	Description
1	2	Upright	20	2	Weight Rest Cap
2	1	Crossbar	21	2	19mm Round Inner Cap
3	1	Frame	22	4	M6 Washer
4	1	Front Leg	23	1	M10 x 135mm Bolt
5	4	Pad Cap	24	4	M6 x 16mm Screw
6	1	Leg Lever	25	1	M10 x 60mm Bolt
7	2	Backrest Tube	26	4	50mm Square Outer Cap
8	1	Backrest	27	2	M8 x 70mm Bolt
9	1	Seat	28	2	M8 x 45mm Bolt
10	1	Spring Clip	29	2	M8 Washer
11	1	25mm Round Inner Cap	30	2	M10 Washer
12	2	Pad Tube	31	2	M10 Locknut
13	4	Foam Pad	32	4	M6 x 40mm Screw
14	1	Backrest Support	33	4	M8 x 65mm Bolt
15	2	Weight Rest	34	8	M8 Locknut
16	3	50mm Square Inner Cap	35	2	Upright Plate
17	1	25mm Round Angled Cap	*	–	User's Manual
18	2	38mm Square Inner Cap	*	–	Exercise Guide
19	4	25mm Square Inner Cap	*	–	Grease Packet

Note: Specifications are subject to change without notice. For information about ordering replacement parts, see the back cover of this manual. *These parts are not illustrated.

EXPLODED DRAWING

Model No. WEBE60020.0 R0820A

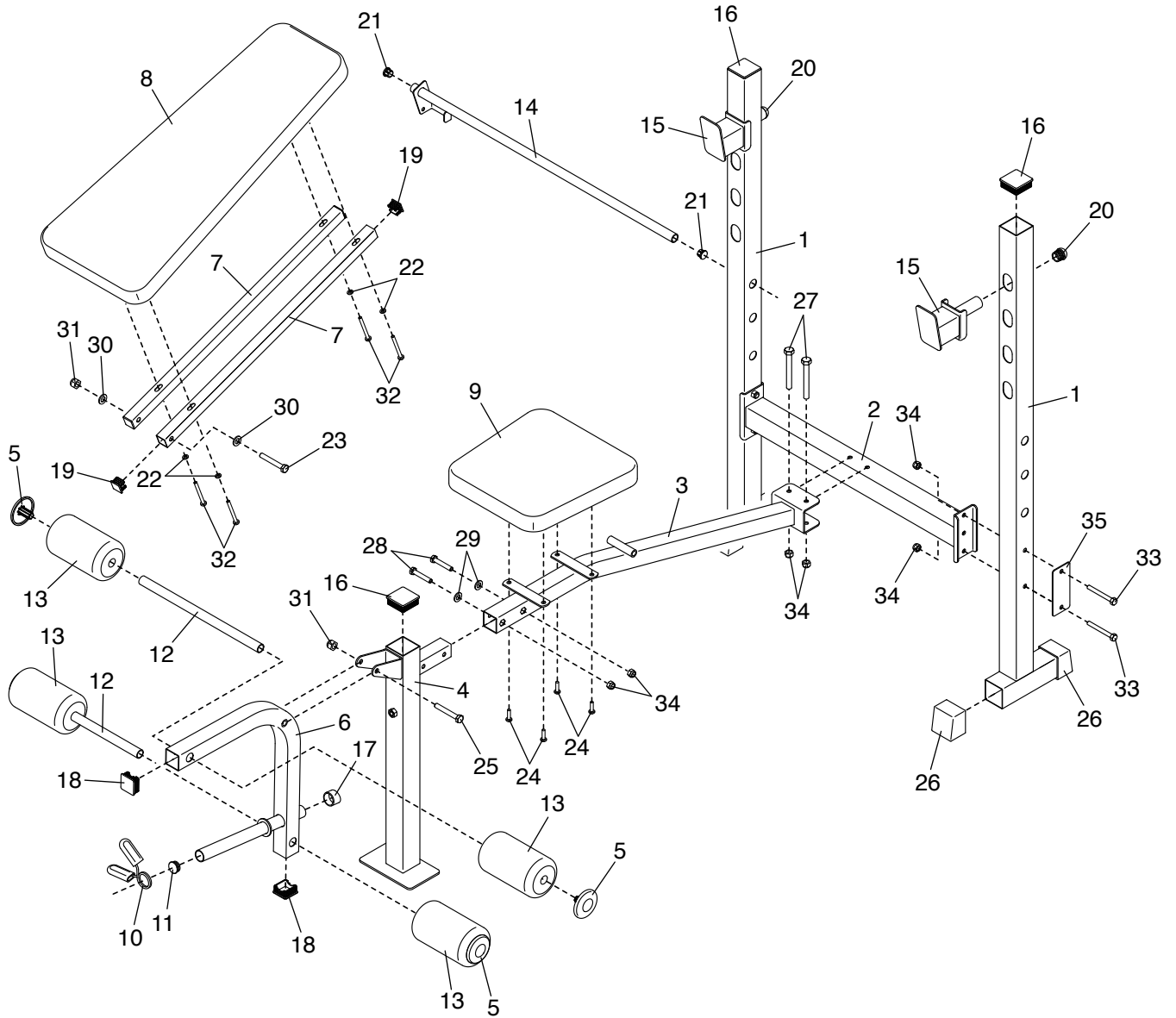

ORDERING REPLACEMENT PARTS

To order replacement parts, please see the front cover of this manual. To help us assist you, be prepared to provide the following information when contacting us:

- the model number and serial number of the product (see the front cover of this manual)
- the name of the product (see the front cover of this manual)
- the key number and description of the replacement part(s) (see the PART LIST and the EXPLODED DRAWING near the end of this manual)

LIMITED WARRANTY

IMPORTANT: To protect your fitness equipment with an extended service plan, see page 4.

ICON Health & Fitness, Inc. (ICON) warrants this product to be free from defects in workmanship and material, under normal use and service conditions. Parts and labor are warranted for ninety (90) days from the date of purchase.

This warranty extends only to the original purchaser (customer) and is not transferrable. ICON's obligation under this warranty is limited to repairing or replacing, at ICON's option, the product through one of its authorized service providers. All repairs for which warranty claims are made must be preauthorized by ICON. If replacement parts are shipped while the product is under warranty, the customer will be responsible for a minimal handling charge. For in-home service, the customer may be responsible for a minimal trip charge. This warranty does not extend to freight damage to the product. This warranty will automatically be voided by the following conditions: (1) if the product is used as a store display model, (2) if the product is purchased or transported outside the USA, (3) if all instructions and warnings in this manual are not followed, (4) if the product is abused or improperly or abnormally used, or (5) if the product is used for commercial or rental purposes. No other warranty beyond that specifically set forth above is authorized by ICON.

ICON is not responsible or liable for the following damages: (1) indirect, special, or consequential damages arising out of or in connection with the use or performance of the product; (2) damages with respect to any economic loss, loss of property, loss of revenues or profits, loss of enjoyment or use, or costs of removal or installation; or (3) other consequential damages of any kind. Some states do not allow the exclusion or limitation of incidental or consequential damages. Accordingly, the above limitation may not apply to the customer.

The warranty extended hereunder is in lieu of any and all other warranties, and any implied warranties of merchantability or fitness for a particular purpose are limited in their scope and duration to the terms set forth herein. Some states do not allow limitations on how long an implied warranty lasts. Accordingly, the above limitation may not apply to the customer. This warranty provides specific legal rights; the customer may have other rights that vary from state to state.

For warranty service, please call the telephone number on the front cover of this manual. Please be prepared to provide the model number and serial number of the product (see the front cover of this manual).

ICON Health & Fitness, Inc., 1500 S. 1000 W., Logan, UT 84321-9813