

CONTENTS

DOWNLOADING THE APP

WEARING

CHARGING

POWERING ON & PAIRING

LED LIGHT GUIDE

CONTROLS

USING SLEEP A30 WITH THE APP

Switch Active Noise Cancellation On/Off

Selecting a Listening Mode

Sleep Audio Setting

Sleep Monitoring

ANSWERING PHONE CALLS

POWERING OFF

RESET

FIRMWARE UPDATE

CLEANING

SPECS

CUSTOMER SERVICE

DOWNLOADING THE APP



Google Play and the Google Play logo are trademarks of Google Inc.



Apple and the Apple logo are trademarks of Apple Inc.



Download the soundcore app to customize controls, listen to soothing sounds, manage your sleep, update firmware, and explore more.

If your earbuds cannot connect with the soundcore app, update it to the latest version in your mobile app store.

Click this link to download: <http://dl-soundcore.soundcore.com/qcdl?flow=soundcore>

WEARING

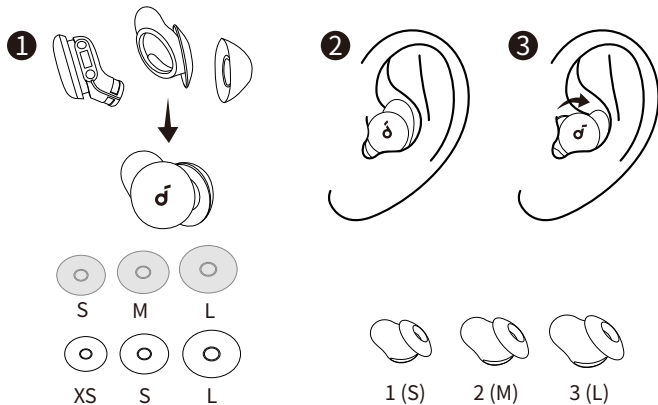

Choose the ear tips and ear wings that fit your ears best. The earbuds come with the M sizes of ear tips and ear wings pre-installed.

To better block out noises, insert the earbuds into your ear canals and turn gently until the ear wings are wedged against your ear ridges.

Note:

- * We provide two types of ear tips. Please choose the one that best suits your noise reduction needs and wearing comfort:
 - Silicone Ear Tips: For optimal comfort;
 - Memory Foam Ear Tips: For enhanced noise blocking. Feels slightly firmer.
- * Memory foam ear tips are consumable items and should be replaced regularly. Do not clean them with alcohol, water, or other liquids.

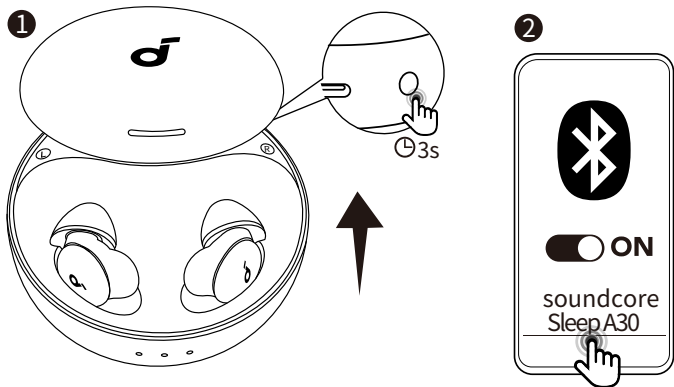

Note: You can also enter pairing mode manually. Place the earbuds in the charging case and leave the case open. Press and hold the button on the back of the charging case for 3 seconds to enter pairing mode.

LED LIGHT GUIDE

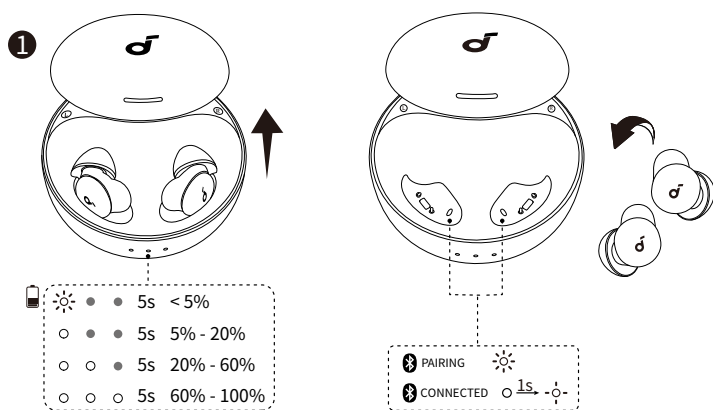

☀	Flashing white rapidly
- 0 -	Flashing white slowly
○	Steady white
●	Light off

CONTROLS

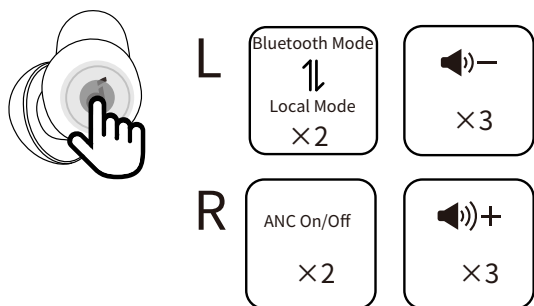

×2 Tap twice ×3 Tap three time

Note:

- * Please note that you need to tap with a bit of force for the earbuds to recognize the command.
- * You can customize more controls in the soundcore app.
- * When using dual earbuds, if you modify UI, it will also be effective when using a single earbud. Vice versa.

USING SLEEP A30 WITH THE APP

Switch Active Noise Cancellation On/Off

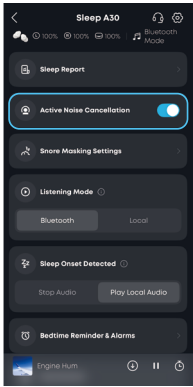

Active Noise Cancellation (ANC) eliminates the background noise from household appliances and outside traffic that affects sleep. Switch ANC on or off by double-tapping the right earbud, or toggle Active Noise Cancellation on or off in the app. Tap controls can also be customized via the app. You can hear a voice prompt when switching.

Note:

- * When you set it to Play Local Audio through Sleep Onset Detected, ANC will automatically turn off after falling asleep is detected.
- * When you set it to Stop Audio through Sleep Onset Detected, ANC will remain in its bedtime setting, with the default set to stay on throughout the night.

Audio Library

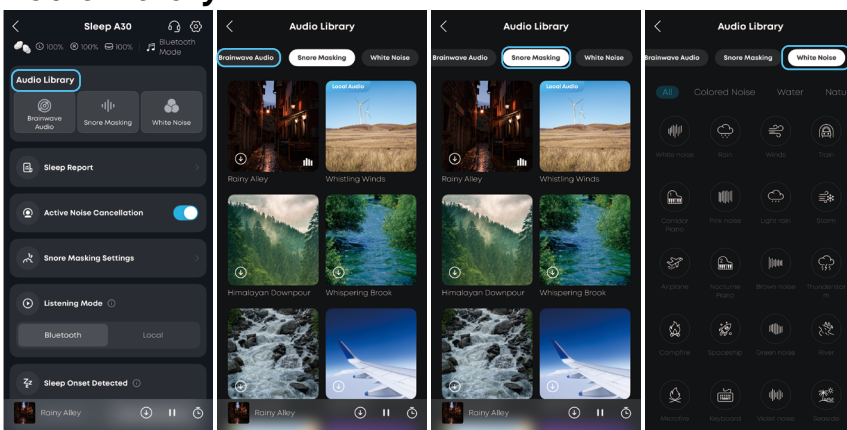

In Audio Library, you can listen to brainwave audio, snore-masking soundscapes, or white noise mix for noise masking, sleep, or relaxation in Bluetooth mode.

AI Brainwave Audio (Stress Relief & Relaxation): Based on principles of neuro musicology and psychoacoustics, this audio combines harmonious scales and intervals with binaural beats to naturally guide your brain into producing relaxing brainwave frequencies. It offers an unlimited "companion-style" music experience to help you sleep, relieve stress, and relax your mind and body.

Masking Soundscapes (Noise & Snore Masking): Carefully curated combinations of rain, wind, water, and other steady, soothing sounds create a calm and stable sleep environment. These soundscapes effectively mask background noise, specifically reducing disruptions from snoring with real-time dynamic EQ adjustment.

White Noise (Personalized): Choose from 62 white noise options and mix them to suit your needs. Create a personalized, calming soundscape to help you relax and focus in any setting.

Downloading Audio Files onto Earbuds

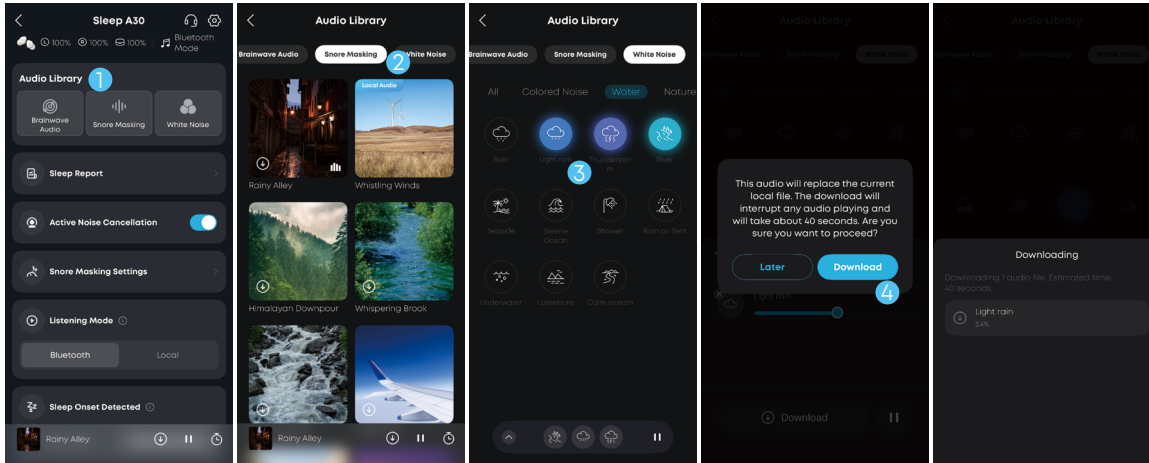

You can also transfer selected Snore Masking or White Noise audio to your earbuds for instant playback in Local Mode.

How to Download Audio onto Earbuds:

1. Go to **Audio Library** on the home page.
2. Tap **Snore Masking** or **White Noise**.
3. Select your preferred sounds and tap the download icon.
4. Tap **Download** to transfer the audio to the earbuds.
5. Wait for the download transfer to complete.

Supported Audio Types:

- Snore Masking Soundscape
- White Noise

Selecting a Listening Mode

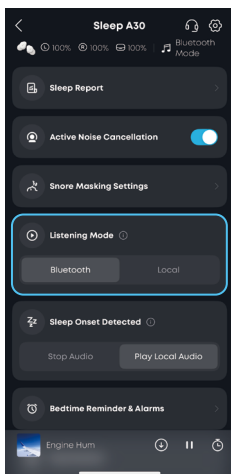

The listening mode determines your audio source. You can switch between Bluetooth and Local mode by double-tapping the left earbud or choosing between Bluetooth and Local mode in the app. You can hear a voice prompt when switching listening modes.

Bluetooth Mode: Play from your Audio Library or connect to other apps to stream your favorite audio content.

Local Mode: Without using your phone, listen to the soothing sounds downloaded onto your earbuds for instant use. And enjoy your rest without interruptions from phone notifications. The default is Snore Masking.

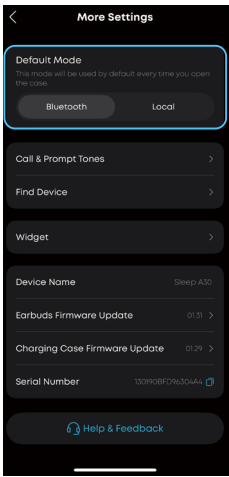

Note: You can set the default mode via the app.

Sleep Audio Setting

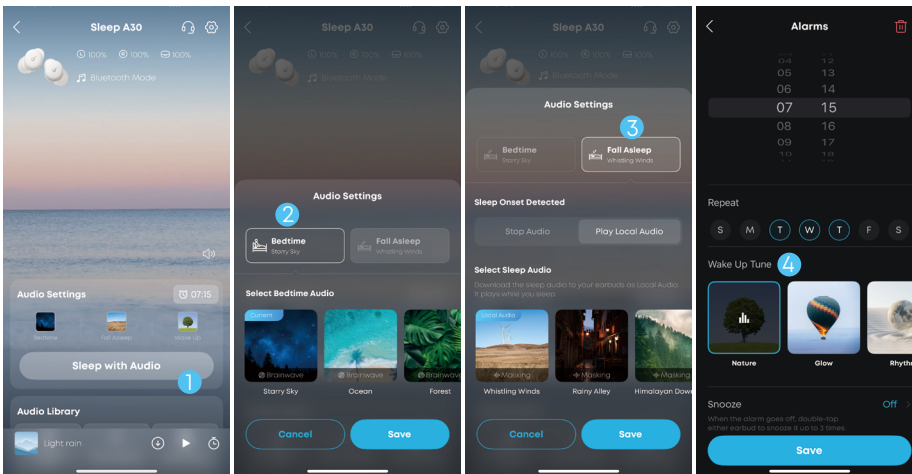

Start Your Personalized Audio Journey with One Tap: From Bedtime to Sleep, and Wake Up

Bedtime: Choose your preferred audio for relaxation or noise masking before sleep. Options include Brainwave Audio, Snore-Masking soundscapes, or custom white noise.

Fall Sleep: Adjust your earbuds' playback settings after detecting that you are asleep through Sleep Onset Detection:

- * Stop Audio: All audio will stop automatically. ANC will remain in its bedtime setting, with the default set to stay on throughout the night.
- * Play Local Audio: The sounds you listen to will be switched to local audio after you fall asleep. ANC will automatically turn off until the earbuds detect you have woken up. You can also adjust playback settings after sleep in the Sleep Onset Detected section of the homepage.

Wake Up: Wake up to one of four specially designed alarms recommended by soundcore, and set a repeating schedule if needed.

Sleep Monitoring

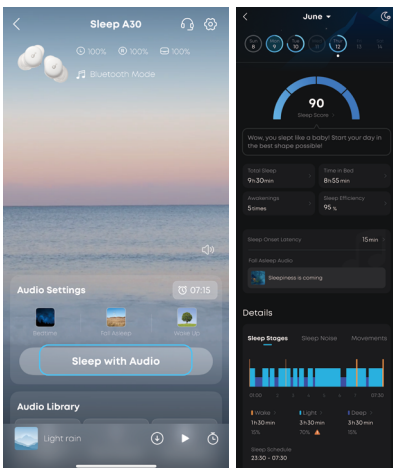

The earbuds track your sleep, including stages, noises, and movements, delivering a detailed report on your sleep patterns.

Two Ways to Track Your Sleep:

Manual Tracking via app (Bluetooth Mode): Tap Sleep With Audio on the homepage to track sleep. The sleep report will be shown after your sleep ends (with the sleep duration exceeding 30 minutes). In this way, we can accurately record your sleep onset latency.

Automatic Tracking via Earbuds (Bluetooth and Local Modes): The earbuds use built-in sensors and algorithms to detect when you fall asleep and automatically track your sleep data. Sleep onset latency is not available in this mode.

ANSWERING PHONE CALLS

Use the app to enable the call feature.

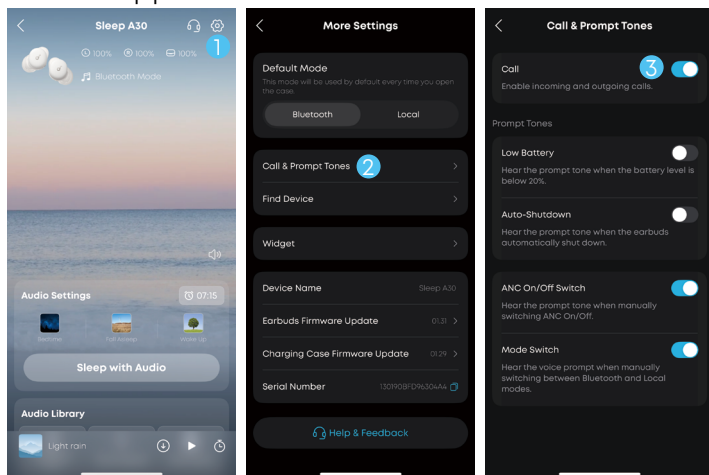

On the homepage, tap the Settings icon, select “Calls and Prompt Tones”, and turn on the Call switch.

Note: This feature is disabled by default.

POWERING OFF

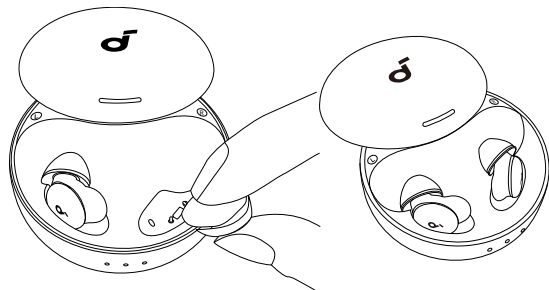

To power off, place the earbuds in the charging case by aligning the charging contacts of both the earbuds and the charging case, and then close the lid.

Once the corresponding earbud is back into the case, the LED indicators inside the charging case will become brighter and start flashing slowly, until the case is closed.

RESET

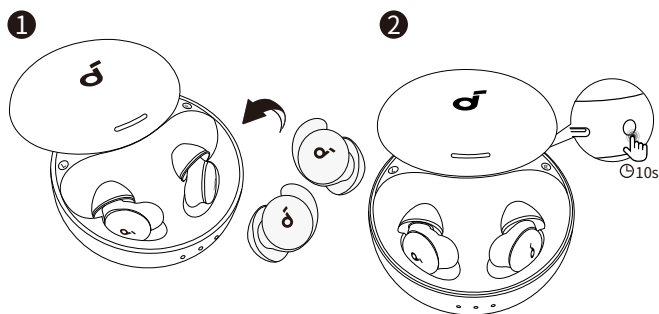

Reset if the earbuds have issues pairing with each other or with other devices.

Delete the pairing history from your Bluetooth device first. Place the earbuds in the charging case and leave the case open. Press and hold the button on the back of the charging case for 10 seconds, until the LED indicators inside the case turn off for 3 seconds.

FIRMWARE UPDATE

You will be informed once the new version of firmware is detected when you connect the earbuds to the app. Ensure the earbuds are placed in the charging case and the case remains open until the firmware update is completed. During the update, ensure the earbuds are being charged and avoid any usage.

CLEANING

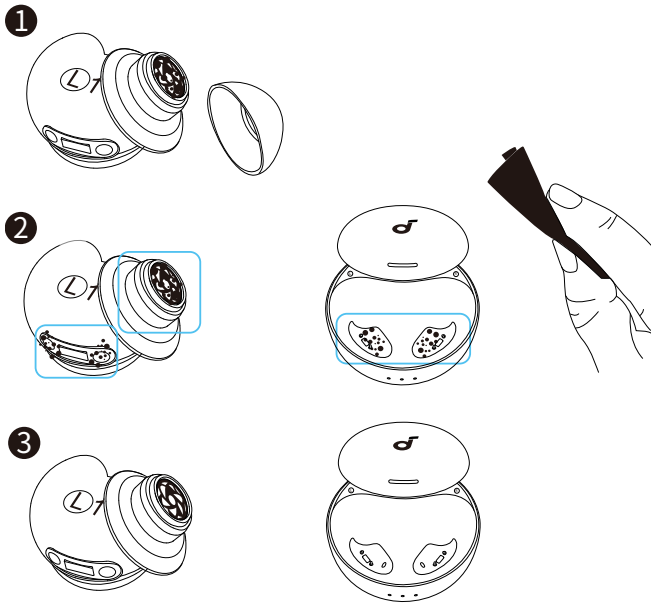

Dust, earwax, or other debris can accumulate in the earbuds. To maintain optimal sound quality, regularly clean your earbuds. Using a cotton swab slightly moistened with rubbing alcohol, gently wipe the metal mesh filter under the rubber ear tips and the charging contacts.

SPECS

Specifications are subject to change without notice.

Input	5V $\overline{\text{---}}$ 0.6A
Output	5V $\overline{\text{---}}$ 0.088A (0.044A per port)
Battery capacity	800mAh/38mAh
Charging time (earbuds)	1.5H
Playtime (earbuds/case)	9/45H
Frequency response	20~20000Hz
Impedance	13.5ohm
Waterproof rating (earbuds)	IPX4
Bluetooth version	soundcore Sleep A30 supports Bluetooth 5.4. However, due to device limitations, it may be displayed as Bluetooth 5.3.
Bluetooth range	10m

CUSTOMER SERVICE



service@soundcore.com
support.mea@soundcore.com (For Middle East and Africa Only)
support@anker.com (日本)
support.kr@anker.com (한국)



+1 (800) 988 7973 (US/Canada)
+44 (0) 1604 936200 (UK)
+49 (0) 69 9579 7960 (DE)
03 4455 7823 (日本)
+86 400 0550 036 (中国)
+82 1666-8470 (한국)
+971 8000320817 (UAE)
+966 8008500030 (KSA)
+965 22069086 (Kuwait)
+20 8000000826 (Egypt)
+90 (850) 460 14 14 (Türkiye)
+8 (800) 511-86-23 (Russia)
000-8000-504-414 (India)

Note: The 'x' of SN Code: xxxxxxxxxxxxxxxx is a variable, see below table.

Variable 'x'	Range of variable	Content
Eighth	8,9,A,B,C...	Denotes the year, 8 means 2018, 9 means 2019, A means 2020, B means 2021, C means 2022, and so on.
Ninth and tenth	01,02,03...	Denotes weeks, 01 means the first week in this year, 02 means the secondary week in this year, and so on.
Eleventh	1-7	Denotes date, 1 means Monday, 2 means Tuesday..., 7 means Sunday and so on.
The last five	00001-99999	Denotes serial No.

Hereby, Anker Innovations Limited declares that this device is in compliance with The Product Security and Telecommunications Infrastructure (Security Requirements for Relevant Connectable Products) Regulations 2023. For the Statement of Compliance, visit the website: <https://uk.soundcore.com/pages/psti-related>.