

# SIT-TO-STEP high chair

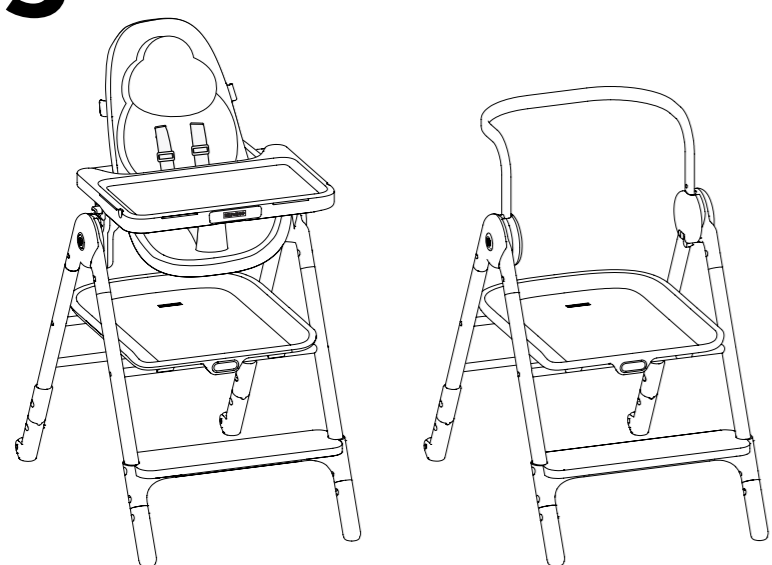

## OWNER'S MANUAL

© 2019 Skip Hop, Inc.  
SKIP HOP and MUST-HAVES MADE BETTER  
are trademarks owned by Skip Hop, Inc.  
All rights reserved.

50 W 23 ST, NY, NY 10010  
In the US: 888.782.9548  
www.skiphop.com  
Made in China

Meets or exceeds applicable  
safety standards.

Please read all instructions before assembly and use of Sit-to-Step High Chair.

### IMPORTANT! READ CAREFULLY AND KEEP FOR FUTURE REFERENCE.

#### HIGH CHAIR:

#### WARNING:

- FOLLOW THE MANUFACTURER'S INSTRUCTIONS.
- DO NOT LEAVE CHILDREN UNATTENDED.
- THE HARNESS MUST ALWAYS BE USED AND CORRECTLY FITTED—MOST INJURIES FROM HIGH CHAIRS ARE CAUSED BY FALLS.
- POSITION THE HIGH CHAIR AWAY FROM SOLID STRUCTURES AND BENCHES TO AVOID INJURIES CAUSED BY FALLS AND BY ACCESS TO DANGEROUS ITEMS.
- USE THIS HARNESS AT ALL TIMES.
- **FALL HAZARD:** Children have suffered severe head injuries including skull fractures when falling from high chairs. Falls can happen suddenly if child is not restrained properly. Prevent your child from climbing on the product.
- Always use the restraint system, and adjust to fit snugly.
- The tray is not designed to hold child in chair.
- Stay near and watch child during use.
- The child should be secured in the high chair at all times by the restraining system, either in the reclining or upright position.
- Never leave the child unattended.
- Do not use the product unless all components are correctly fitted and adjusted.
- Be aware of the risk of open fires and other sources of strong heat in the vicinity of the product.
- Be aware of the risk of tilting when your child can push its feet against a table or any other structure.
- Do not use the product if any part is broken, torn or missing.
- Keep children away when unfolding and folding the product to avoid injury.
- Discontinue use of the recline high chair mode when child is able to sit upright unassisted or weighs more than 20 lb (9.1 kg).
- The upright high chair mode is intended for children able to sit up unaided and up to 3 years max weight of 33lb / 15kg.
- The high chair shall be on a flat, even and horizontal floor and do not elevate the high chair on any structure or table.
- To reduce the risk of injury, the position of the high chair shall be away from furniture, walls, hot surfaces and liquids, window covering cords, and electrical cords and position the high chair away from furniture when the chair is not being used at a table with a tray removed.
- The high chair should only be used in an upright position once the child is capable of reliably and consistently sitting upright.
- Check this product regularly for damaged hardware, loose joints, missing parts or sharp edges before and after assembly and frequently during use. DO NOT use chair if any parts are missing, damaged or broken. Do not use substitute parts.
- Do not use the high chair if it is not working correctly until repaired. Regularly inspect and maintain high chair.
- Do not allow adults or older children to sit in high chair.
- Avoid injury from pinching. Keep children's hands and feet clear of arm rest when securing tray.

#### KITCHEN HELPER:

#### WARNING:

- Never leave child unattended.
- The product shall be placed in a free area, far from obstacles on which the child may fall down and be hurt.
- The product shall be assembled by an adult.
- The child may have access to dangerous locations due to this Kitchen Helper, such as doors of storage units or drawers, doors or windows handles. Therefore, the Kitchen Helper should be stored out of reach of the child when not in use.
- Kitchen Helper maximum load is 200 lb / 91 kg.

#### 3 USES:

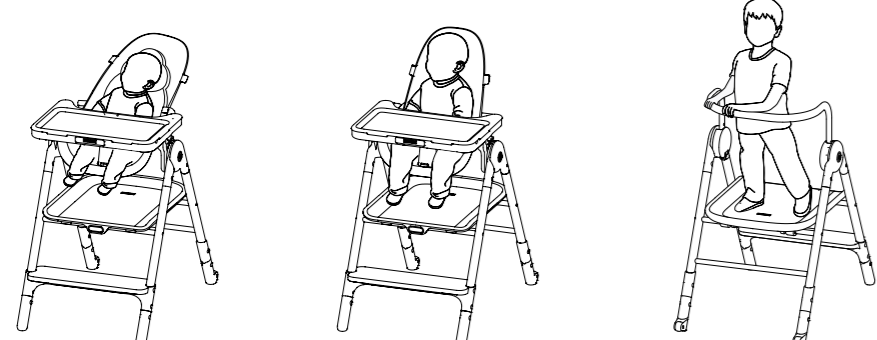

- 1. Reclined High Chair**  
for bottle feeding  
(3 - 6 months)
- 2. Upright High Chair**  
for solid foods  
(6 months - 3 years)
- 3. Kitchen Helper**  
for giving big kids a boost  
(3 years - 6 years)

#### CONTENTS:

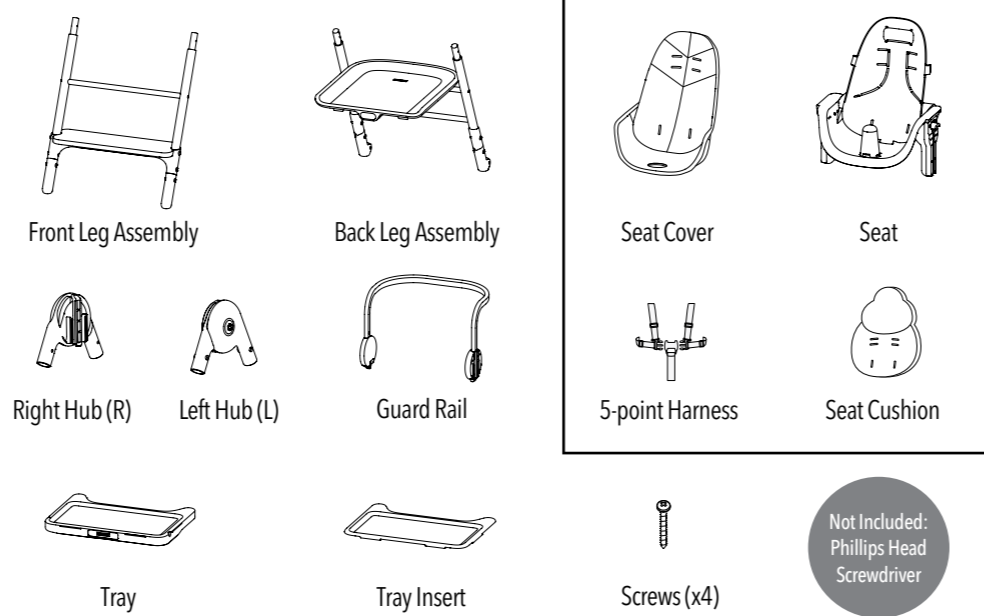

#### FIRST TIME ASSEMBLY: HIGH CHAIR MODE

Adult assembly required.

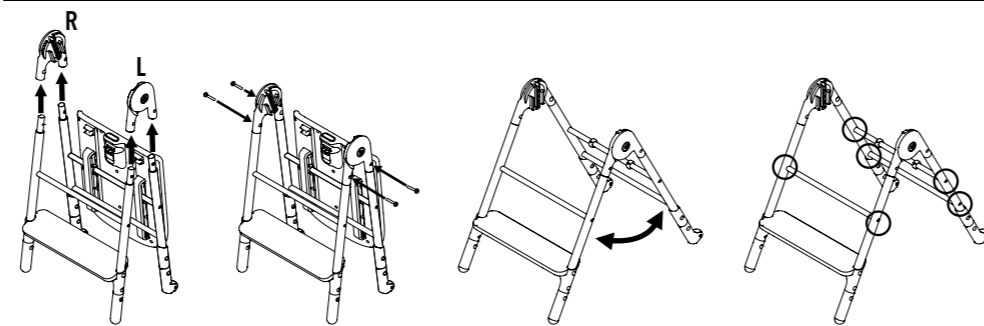

1. Insert Front and Back Leg Assemblies into Right and Left Hubs.
2. Insert screws from outside and tighten with screwdriver.
3. Open the leg structure by pressing buttons on Hubs while pulling Front and Back Leg Assemblies apart.
4. Tighten all six crossbar screws using the screwdriver. These may have become loose in transit.

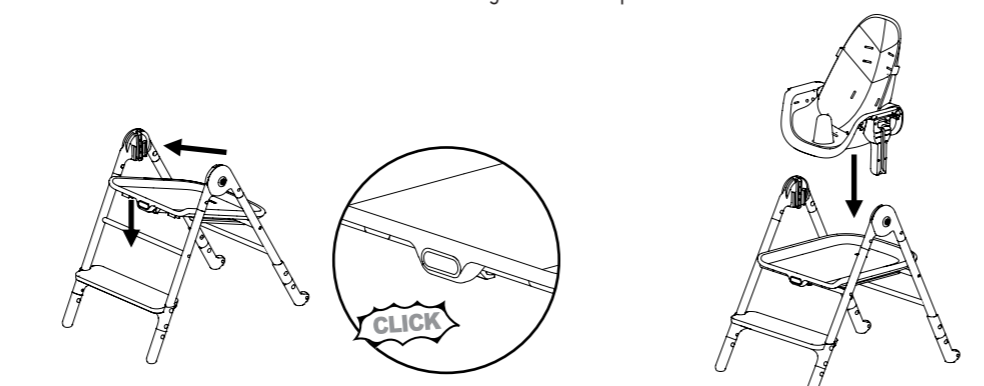

5. Lift and slide platform into place, pushing the front down on to the crossbar until you hear a "click".
6. Line up Seat posts with the slots on the Hubs and lower into place. Make sure wheels are in the back. You will hear a "click" when the Seat reaches each position. There are three heights to choose from. Make sure both sides of the seat are adjusted to the same height before putting baby into the High Chair.

**IMPORTANT: Check all screws and connections periodically and tighten as needed to ensure safety.**

#### FIRST TIME ASSEMBLY: SEAT

Adult assembly required.

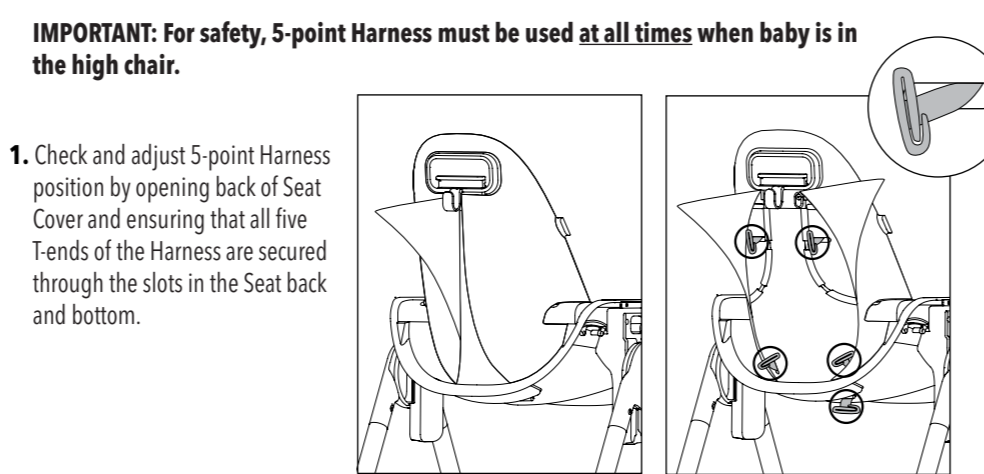

1. Check and adjust 5-point Harness position by opening back of Seat Cover and ensuring that all five T-ends of the Harness are secured through the slots in the Seat back and bottom.

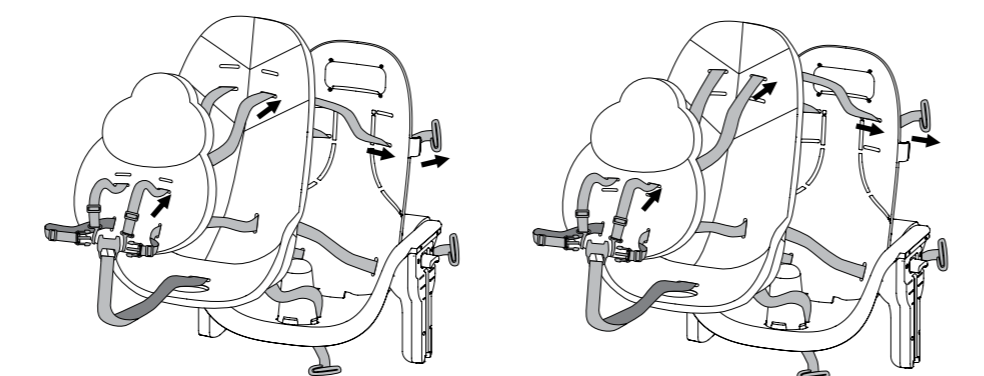

2. If you need to adjust the shoulder strap position, use the lowest shoulder position for younger babies and adjust as they grow.
3. Pull forcefully on 5-point Harness to ensure that it is secure, and close Seat Cover back.

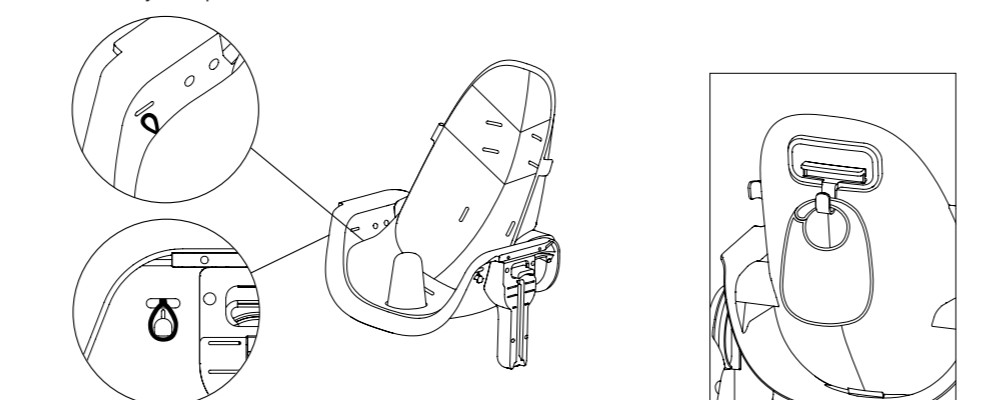

4. Make sure elastic loops on Seat Cover are fed through slots on side of Seat and looped over the buttons.
5. Use hook to hang bibs.

#### FIRST TIME ASSEMBLY: TRAY

Adult assembly required.

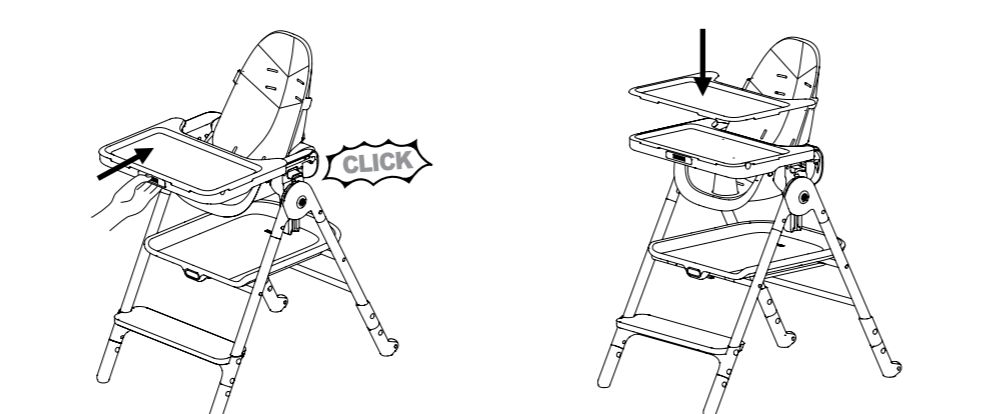

- Attach Tray by pressing center button while sliding it into position on the Seat. You will hear a "click" when it reaches each position.
- Attach Tray insert by snapping into place on top of Tray.

#### DIRECTIONS FOR USE: SEAT HEIGHT ADJUSTMENT

**IMPORTANT: Do NOT adjust the seat height while baby is in the High Chair.**

To adjust the Seat height, push buttons on both sides in and up while lifting or lowering the Seat.

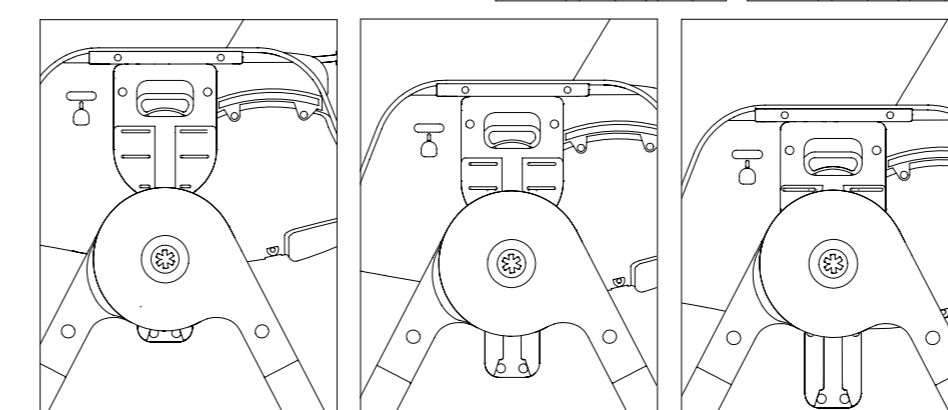

There are three heights to choose from. Make sure both sides of the seat are adjusted to the same height before putting baby into the High Chair.

#### DIRECTIONS FOR USE: 5-POINT HARNESS

**IMPORTANT: Use the 5-point Harness at all times to ensure that baby is safe and secure while seated.**

1. Place baby in seat.
2. Check that the shoulder straps are attached to waist belt.
3. Position the crotch strap through baby's legs and feed arms through shoulder straps.
4. Close buckles. You should hear a "click" sound.
5. Adjust sliders for a snug fit (adjust as baby grows).
6. Check to be sure the harness is securely attached by pulling away from baby; it should remain attached.

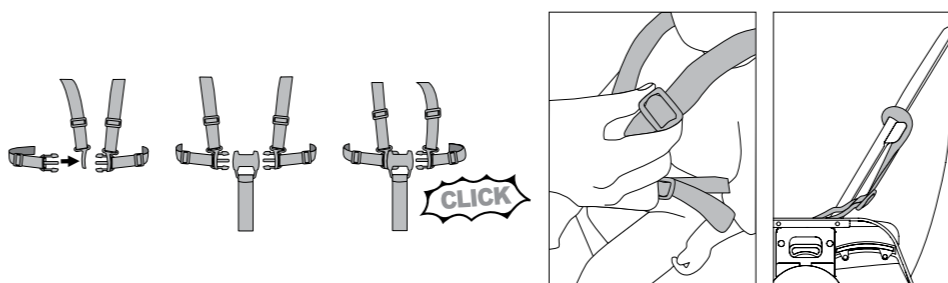

#### To adjust the shoulder height:

Open the back of the Seat Cover by separating the hook-n-loop closure. Feed T-end of the shoulder strap through Seat back and Cushion to remove it. Re-insert the T-end through the desired slot on Cover and feed through corresponding slot on Seat back. Pull to ensure it is secured and repeat on the remaining shoulder strap. Close back of Cover and secure with hook-n-loop closure.

When removing baby from harness, loop the shoulder straps over the hooks on Seat sides. This will make it easy to take baby out and put them back in.

#### DIRECTIONS FOR USE: TRAY POSITION

To attach, adjust or remove the Tray, press the button on front of Tray and slide into place.

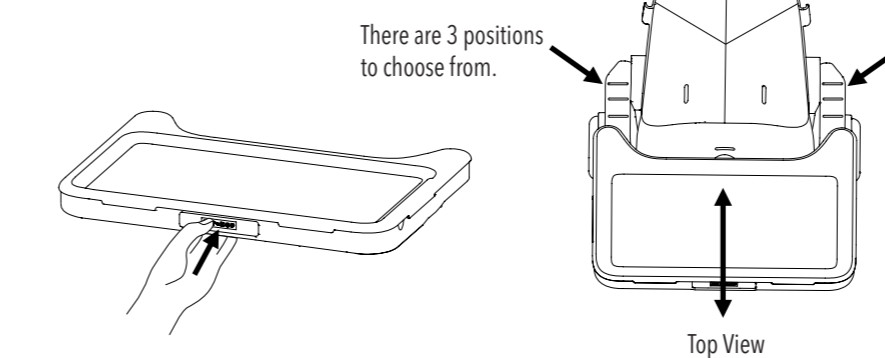

#### DIRECTIONS FOR USE: SEAT RECLINE

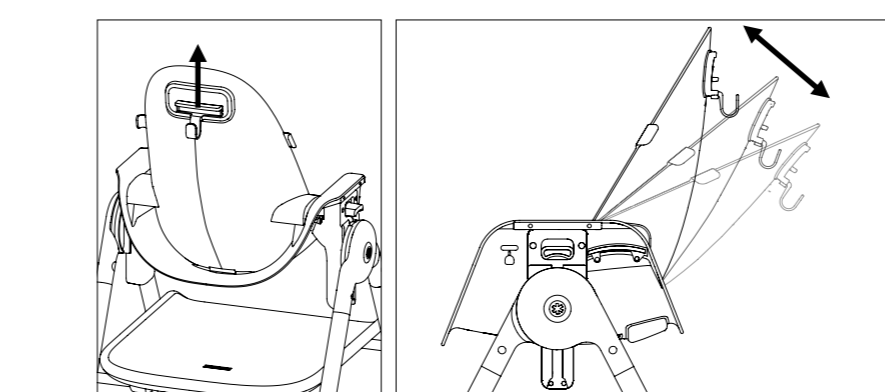

Pull up lever located on back of seat while lowering the seat back into one of three positions.

#### DIRECTIONS FOR USE: REAR WHEELS

**IMPORTANT: Never move the High Chair while baby is seated inside!**

The Sit-to-Step High Chair includes rear wheels to make it easier to move from place to place. Simply tip back to engage the wheels.

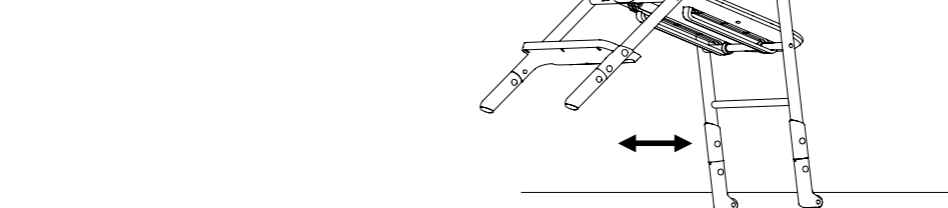

#### DIRECTIONS FOR USE: FOLD FOR STORAGE

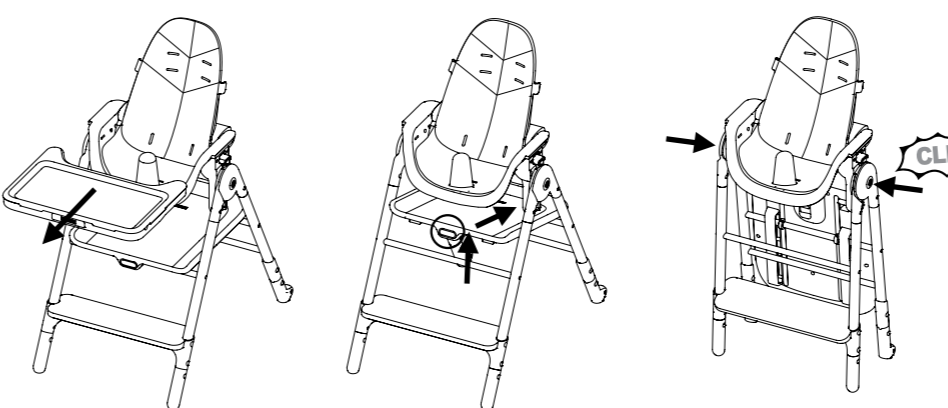

1. (Optional) Remove Tray.
2. Unlock platform by pressing button on front and pulling up. Slide platform back so that it hangs from back crossbar.
3. Standing in front of High Chair, push buttons on sides of Hubs while pivoting High Chair toward you so that the rear legs lift up and the base closes. You will hear a "click" when it is locked in place.

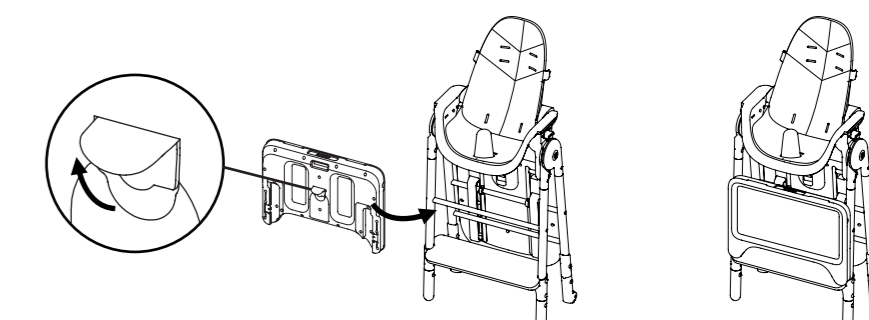

4. Use hook on back of Tray to hang from crossbar.

#### KITCHEN HELPER CONVERSION

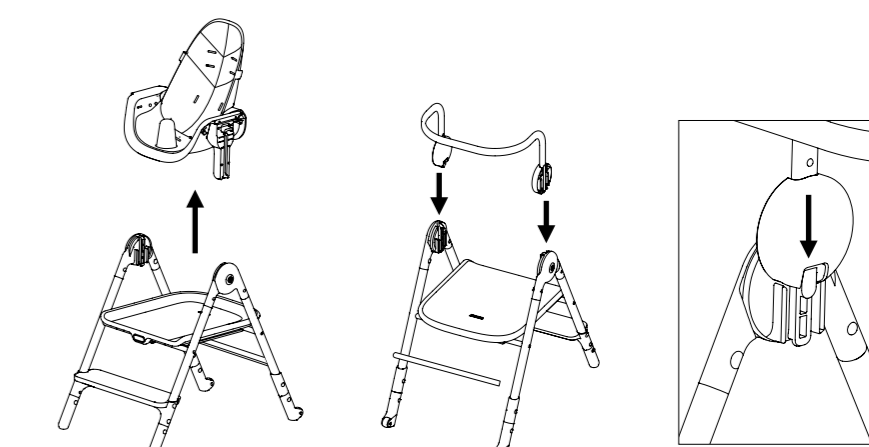

1. Remove Seat by pressing buttons on sides in and up and lifting Seat off the base.
2. Attach the Guardrail by lining up the slots on the Guardrail with the slots on the Hubs and squeezing the two pieces together gently while sliding the Guardrail into place. You will hear a "click" when the Guardrail is secure. Make sure wheels are in the back.
3. Pull up on both sides of the Guardrail to ensure it is securely attached.
4. Check the platform to ensure that it is locked onto the front crossbar.

**IMPORTANT: Check all screws and connections periodically and tighten as needed to ensure safety.**

#### DIRECTIONS FOR USE: KITCHEN HELPER MODE

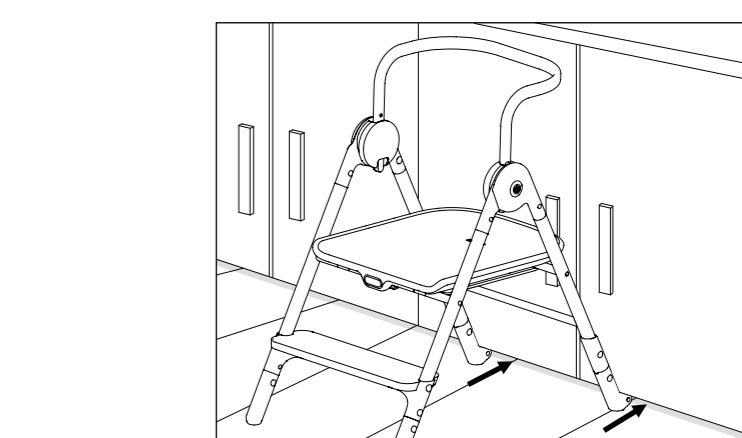

Kitchen helper mode should be used only for children age 3 years and up, who are able to walk and climb stairs unassisted. Push Kitchen Helper as close to counter or table as possible for maximum stability.

#### DIRECTIONS FOR USE: REAR WHEELS

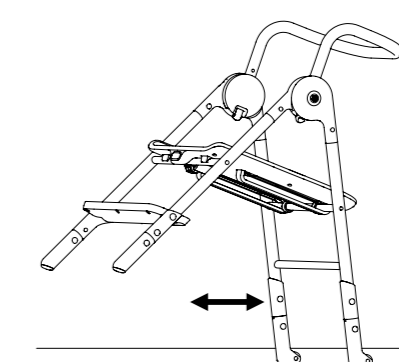

**IMPORTANT: Never move the Kitchen Helper while child is using it!**

The Sit-to-Step High Chair includes rear wheels to make it easier to move from place to place. Simply tip back to engage the wheels.

#### DIRECTIONS FOR USE: FOLD FOR STORAGE

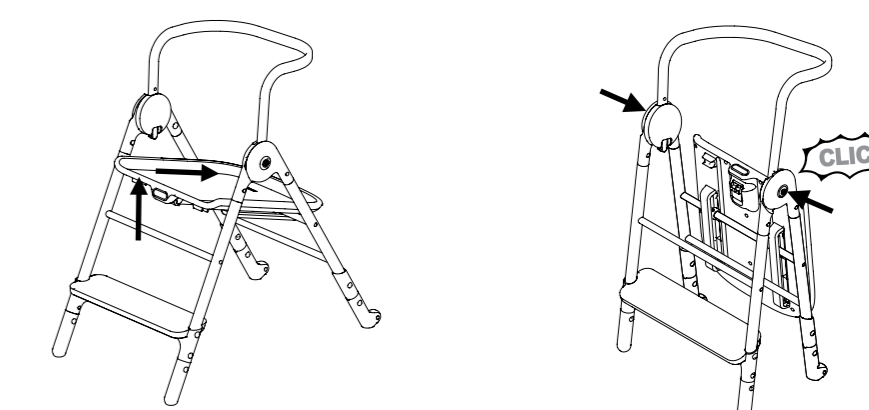

1. Unlock platform by pressing button on front and pulling up. Slide platform back so that it hangs from back crossbar.
2. Standing in front of Kitchen Helper, push buttons on sides of Hubs while pivoting Kitchen Helper toward you so that the rear legs lift up and the base closes. You will hear a "click" when it is locked in place.

#### DIRECTIONS FOR USE: GUARDRAIL REMOVAL

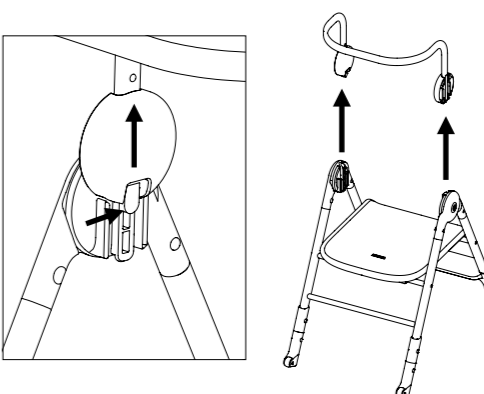

**IMPORTANT: Never use the Kitchen Helper without the Guardrail in place!**

To remove Guardrail for storage or to convert back to High Chair Mode, pull tabs at the bottom of Guardrail and pull up to disengage from main Hubs. Pull up on Guardrail to remove.

#### CLEANING & CARE:

**Tray:** Wipe clean with a damp sponge or cloth. Do not microwave or put in dishwasher. Do not submerge in water.

**Tray Insert:** Dishwasher-safe or wipe clean.

**Guardrail:** Wipe clean with damp sponge or cloth.

**Seat Cover and Seat Cushion:** Machine wash cold, gentle cycle. No bleach. Dry flat. Do not iron. Do not dry clean. See "First Time Assembly: Seat" to re-attach Seat Cover.

**Seat (structure):** Wipe clean with damp sponge or cloth.

**Platform:** Wipe clean. Do not let your child step on to platform until it is dry.

**5 Point Harness:** Surface wash only. Wipe with a damp sponge or cloth and air dry. Do not use bleach.



Scan QR code to view instructional video.