

# BODYTRAC™

## GLIDER

## Owner's Manual

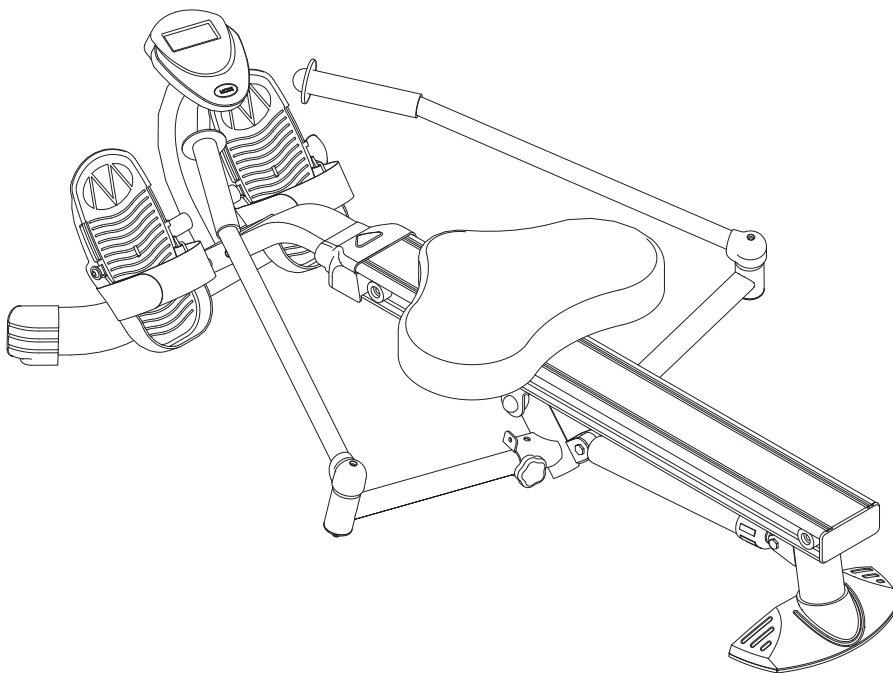

Product May Vary Slightly From Pictured.

### CAUTION:

Weight on this product should not exceed 250 lbs.

This Product is Distributed Exclusively by



2040 N. Alliance, Springfield, MO 65803

Customer Care

1 (800) 375-7520

[www.staminaproducts.com](http://www.staminaproducts.com)

### ⚠ WARNING

Exercise can present a health risk. Consult a physician before beginning any exercise program with this equipment. If you feel faint or dizzy, immediately discontinue use of this equipment. Serious bodily injury can occur if this equipment is not assembled and used correctly. Serious bodily injury can also occur if all instructions are not followed. Keep others and pets away from equipment when in use. Always make sure all bolts and nuts are securely tightened prior to each use. Follow all safety instructions in this manual.

When calling for parts or service, please specify the following number:

**Model#: 35-1050D**

**STAMINA PRODUCTS  
MADE IN CHINA**

© 2016 Stamina Products, Inc.  
2016, 01

## TABLE OF CONTENTS

Safety Instructions .....	2	Conditioning Guidelines .....	15
Before You Begin .....	4	Warm-Up and Cool-Down .....	16
Equipment Warning, Caution & Notice Labels ...	5	Warranty .....	17
Hardware Identification Chart .....	6	Product Parts Drawing .....	18
Assembly Instructions .....	7	Parts List .....	19
Operational Instructions .....	12	Notes .....	21
Maintenance .....	13	Fax/Mail Ordering Form .....	22
Storage .....	14		

## SAFETY INSTRUCTIONS

**⚠ WARNING** This product contains a chemical known to the State of California to cause cancer and birth defects or other reproductive harm.

**⚠ WARNING** Consult your physician before starting this or any exercise program. This is especially important if you are over the age of 35, have never exercised before, are pregnant, or suffer from any health problem. This product is for home use only. Do not use in institutional or commercial applications. Failure to follow all warnings and instructions could result in serious injury or death.

**⚠ WARNING** To reduce the risk of serious injury, read the following Safety Instructions before using the **BodyTrac™ Glider**.

1. Save these instructions and ensure that other exercisers read this manual prior to using the **BodyTrac™ Glider** for the first time.
2. Read all warnings and cautions posted on the **BodyTrac™ Glider**.
3. The **BodyTrac™ Glider** should only be used after a thorough review of the Owner's Manual. Make sure that it is properly assembled and tightened before use.
4. We recommend that two people be available for assembly of this product.
5. Keep children away from the **BodyTrac™ Glider**. Do not allow children to use or play on the **BodyTrac™ Glider**. Keep children and pets away from the **BodyTrac™ Glider** when it is in use.
6. It is recommended that you place this exercise equipment on an equipment mat.
7. Set up and operate the **BodyTrac™ Glider** on a solid level surface. Do not position the **BodyTrac™ Glider** on loose rugs or uneven surfaces.
8. Make sure that adequate space is available for access to and around the **BodyTrac™ Glider**.
9. Keep fingers clear of all pinch points when folding and unfolding the **BodyTrac™ Glider**.
10. Before using, inspect the **BodyTrac™ Glider** for worn or loose components, and securely tighten or replace any worn or loose components prior to use.
11. Shocks on rowers get **HOT** during use. To avoid burns, do not touch the shock until it has time to cool.
12. Consult a physician prior to commencing an exercise program and follow his/her recommendations in developing your fitness program. If at any time during exercise you feel faint, dizzy, or experience pain, stop and consult your physician.
13. Always choose the workout which best fits your physical strength and flexibility level. Know your limits and train within them. Always use common sense when exercising.
14. Do not wear loose or dangling clothing while using the **BodyTrac™ Glider**.
15. Never exercise in bare feet or socks; always wear proper footwear such as running, walking, or cross training shoes that fit well, provide foot support, and feature non-skid rubber soles.
16. Be careful to maintain your balance while using, mounting, dismounting, or assembling the **BodyTrac™ Glider**, loss of balance may result in a fall and serious bodily injury.
17. Do not use the seat to move the **BodyTrac™ Glider**. The Seat will move and the Seat Carriage may pinch your hand or fingers.
18. The **BodyTrac™ Glider** should not be used by persons weighing over 250 pounds.
19. The **BodyTrac™ Glider** should be used by only one person at a time.
20. The **BodyTrac™ Glider** is for consumer use only. It is not for use in public or semipublic facilities.



NEED HELP?  
CONTACT US FIRST  
**1 (800) 375-7520**  
[customer.care@staminaproducts.com](mailto:customer.care@staminaproducts.com)

Hi! From all of us here at Stamina Products, thank you for your purchase. We know that you have big fitness goals in mind and we are here to help you along. Call us, email us, or send us a message on Facebook. Be sure to contact us if you have any questions on your new product. We look forward to hearing from you!

With your body in mind,  
***Stamina Customer Care***

To enact your warranty and to help us better serve you,  
please **go online** and register your new product.

**[register.staminaproducts.com](http://register.staminaproducts.com)**

It is quick and easy to register online, but if you're a little old school or just need a reason to raise that little flag on your mailbox, fill out the info on the last page of this manual and mail it in.



**ONLINE**

[customer.care@staminaproducts.com](mailto:customer.care@staminaproducts.com)  
[www.staminaproducts.com](http://www.staminaproducts.com)



**TELEPHONE**

1 (800) 375-7520



**FAX**

(417) 889-8064



**MAIL**

Stamina Products, Inc.  
ATTN: Customer Care  
P.O. Box 1071  
Springfield, MO 65801-1071

 [facebook.com/StaminaProducts](https://facebook.com/StaminaProducts)  
[facebook.com/AeroPilates](https://facebook.com/AeroPilates)

**CUSTOMER CARE HOURS:**  
Monday-Thursday, 7:30 AM-5:00 PM, Central Time  
Friday, 8:00 AM-3:00 PM, Central Time

## BEFORE YOU BEGIN

Thank you for choosing the **BodyTrac™ Glider**. We take great pride in producing this quality product and hope it will provide many hours of quality exercise to make you feel better, look better, and enjoy life to its fullest.

It's a proven fact that a regular exercise program can improve your physical and mental health. Too often, our busy lifestyles limit our time and opportunity to exercise. The **BodyTrac™ Glider** provides a convenient and simple method to begin your journey of getting your body in shape and achieving a happier and healthier lifestyle.

Before reading further, please review the drawing below and familiarize yourself with the parts that are labeled.

Read this manual carefully before using the **BodyTrac™ Glider**.

Although Stamina constructs its products with the finest materials and uses the highest standards of manufacturing and quality control, there can sometimes be missing parts or incorrectly sized parts. If you have any questions or problems with the parts included with your **BodyTrac™ Glider**, please do not return the product. Contact us **FIRST!**

If a part is missing or defective, please go to [staminaproducts.com](http://staminaproducts.com) under the Service section and order the part needed, or call us toll free at 1-800-375-7520 (in the U.S.). Our Customer Care Staff is available to assist you from 7:30 A.M. to 5:00 P.M. (Central Time) Monday through Thursday and 8:00 A.M. to 3:00 P.M. (Central Time) on Friday.

Be sure to have the name and model number of the product available when you contact us.

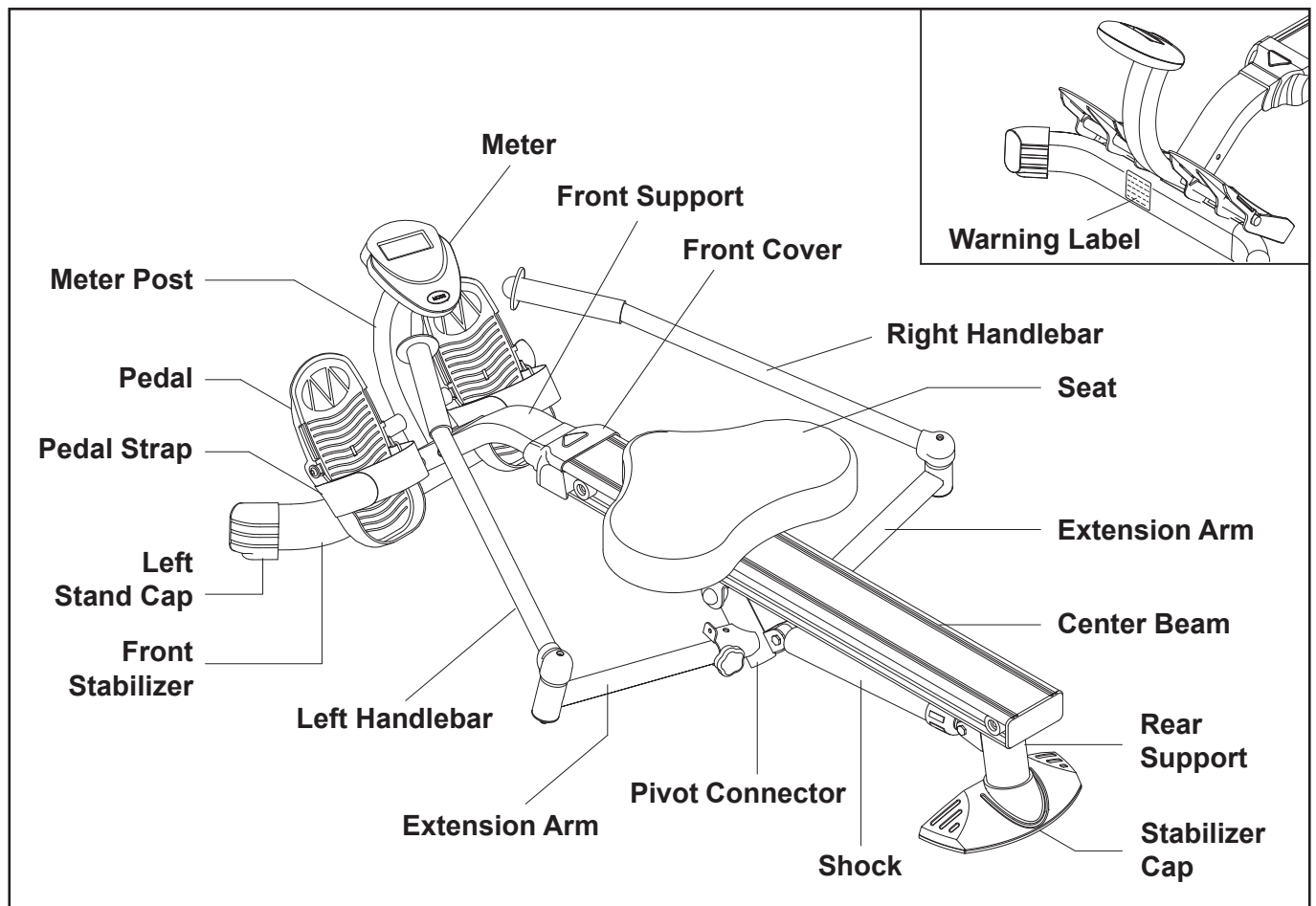

THE FOLLOWING TOOLS ARE REQUIRED FOR ASSEMBLY :



Allen Wrench (5mm)



Allen Wrench (5mm)



Wrench (13mm)

## EQUIPMENT WARNING, CAUTION & NOTICE LABELS

This chart is provided to help identify the warning, caution, and notice labels on the **BodyTrac™ Glider**. Please take a moment to familiarize yourself with all of the warning, caution, and notice labels.

Label is larger than actual size

### **W1** WARNING LABEL(67)



# HARDWARE IDENTIFICATION CHART

This chart is provided to help identify the fasteners used in the assembly process. Place the washers or the ends of the bolts or screws on the circles to check for the correct diameter. Use the small scale to check the length of the bolts and screws.

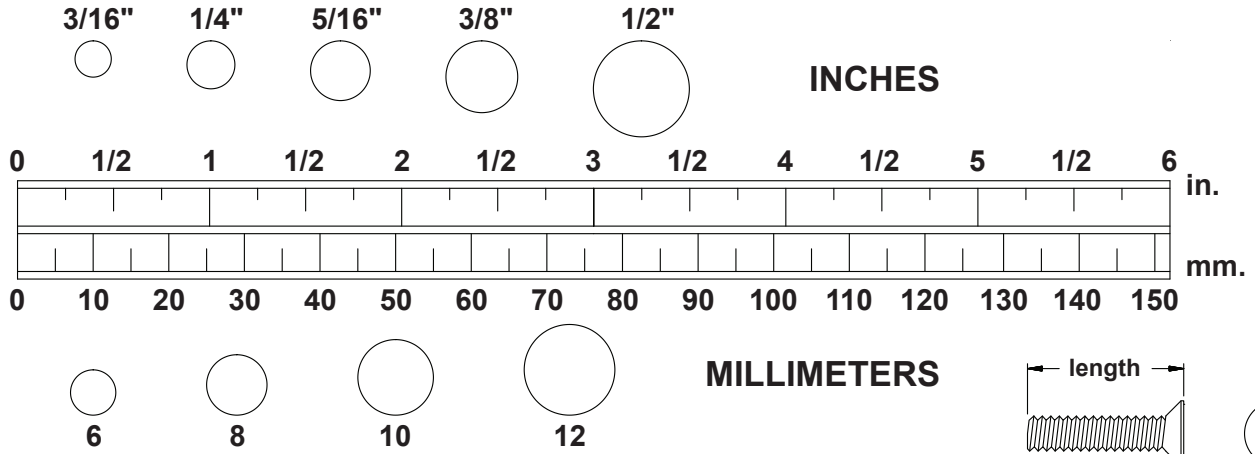

**NOTICE:** The length of all bolts and screws, except those with flat heads, is measured from below the head to the end of the bolt or screw. Flat head bolts and screws are measured from the top of the head to the end of the bolt or screw.

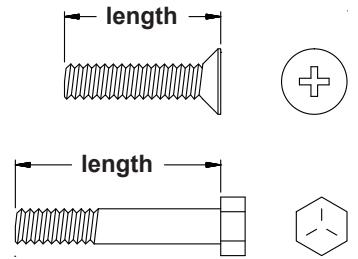

After unpacking the unit, open the hardware bag and make sure that you have all the following fasteners. Some fasteners may be already attached to the parts.

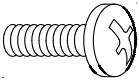
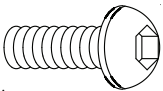
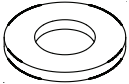
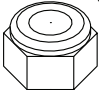
	Part No. and Description	Qty
	49 Screw, Round Head (M5 x 0.8 x 12mm)	2
	51 Bolt, Button Head (M8 x 1.25 x 15mm)	8
	53 Bolt, Button Head (M8 x 1.25 x 25mm)	2
	36 Large Washer (M8)	2
	59 Washer (M8)	8
	62 Nylon Nut (M8 x 1.25)	2

## ASSEMBLY INSTRUCTIONS

Place all parts from the box in a cleared area and position them on the floor in front of you. Remove all packing materials from your area and place them back into the box. Do not dispose of the packing materials until assembly is completed. Read each step carefully before beginning. If you are missing a part, please go to [staminaproducts.com](http://staminaproducts.com) under the Service section and order the part needed, e-mail us at [customer.care@staminaproducts.com](mailto:customer.care@staminaproducts.com), or call us toll free at 1-800-375-7520 (in the U.S.). Our Customer Care Staff is available to assist you from 7:30 A.M. to 5:00 P.M. (Central Time) Monday through Thursday and 8:00 A.M. to 3:00 P.M. (Central Time) on Friday.

### STEP 1

Lay the Main Frame Assembly on the floor as shown in the illustration. Now refer to inset drawing A. Make sure the Key Rib in the **STABILIZER CAP(5)** aligns with the slot in the **REAR SUPPORT(4)**, then press the **STABILIZER CAP(5)** onto the **REAR SUPPORT(4)**. Turn the Main Frame Assembly to the normal upright position and make sure the **STABILIZER PAD(6)** is secured to the **STABILIZER CAP(5)**.

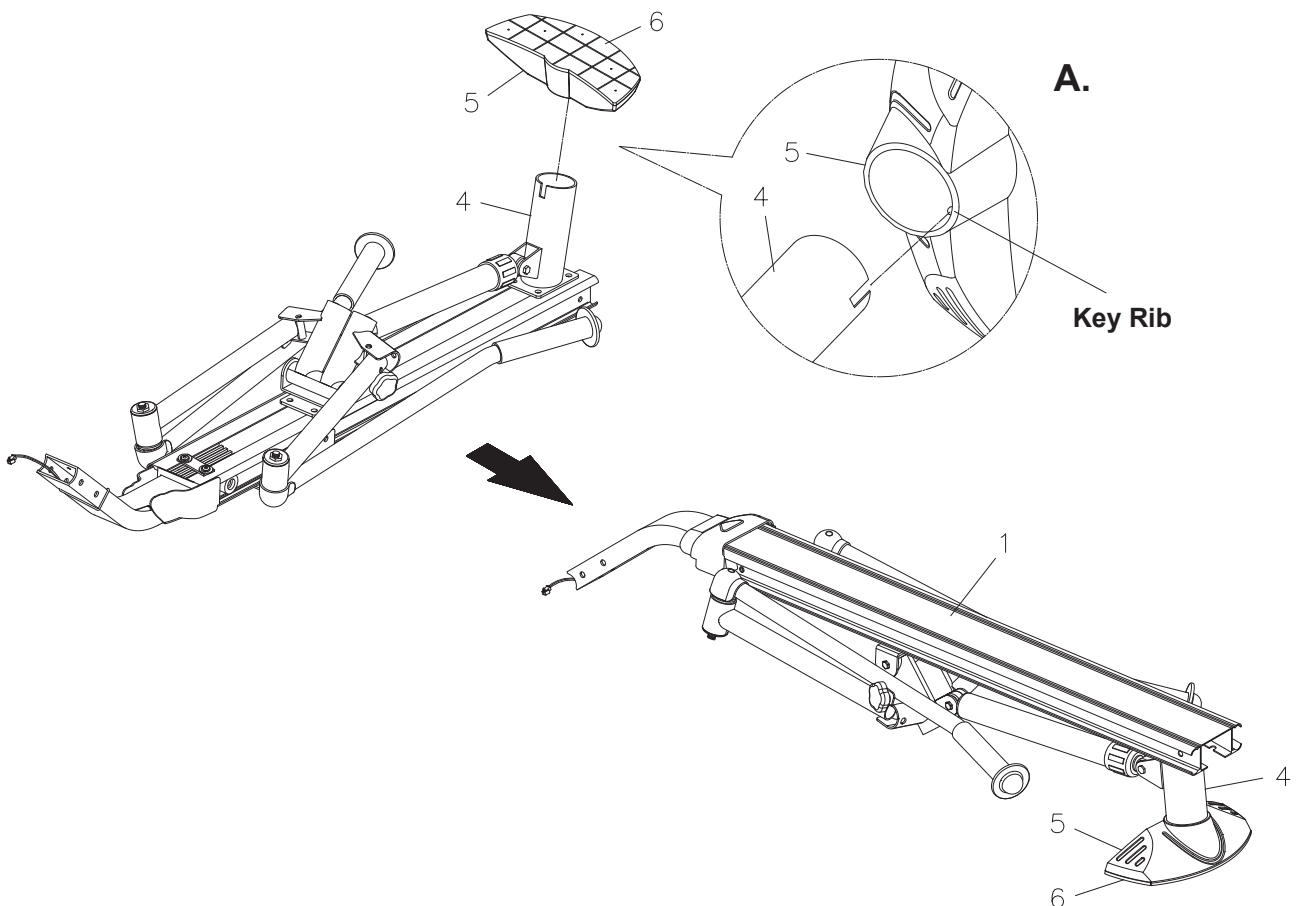

## ASSEMBLY INSTRUCTIONS

### STEP 2

Insert the Bracket on **FRONT STABILIZER(28)** into the **FRONT SUPPORT(26)**. Attach the **METER POST(31)** to the **FRONT SUPPORT(28)**, then bolt the **METER POST(31)**, **FRONT SUPPORT(26)**, and **FRONT STABILIZER(28)** together with **BUTTON HEAD BOLTS(M8x1.25x15mm)(51)** and **WASHERS(M8)(59)**. Please do not tighten any of these bolts until all six bolts are attached.

**NOTE:** Be careful not to damage the **EXTENSION WIRE(38)** when assembling the **METER POST(32)**.

### STEP 3

Connect the **EXTENSION WIRE(39)** to the **SENSOR WIRE(40)**.

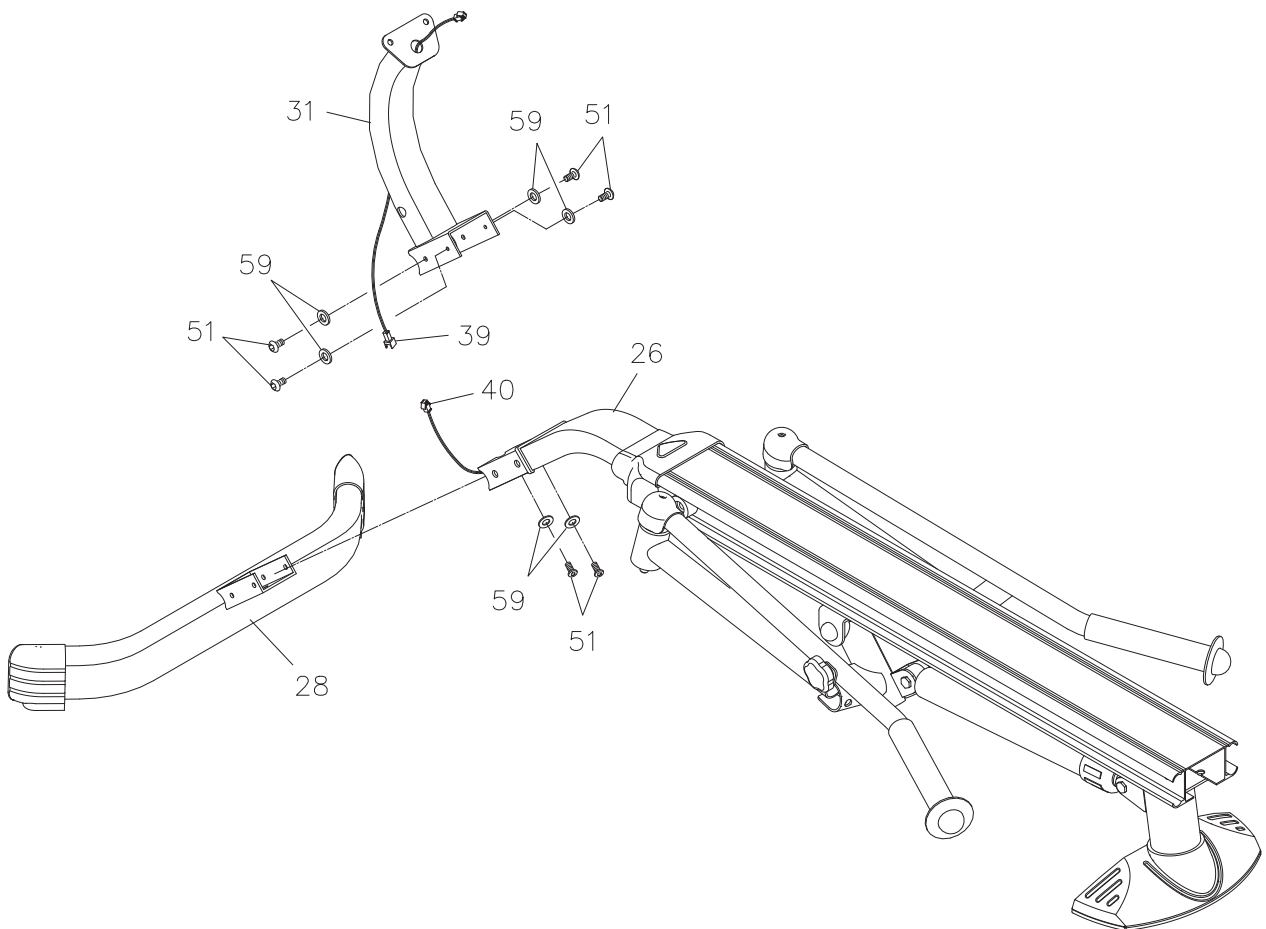

## ASSEMBLY INSTRUCTIONS

### STEP 4

Insert the **PEDAL SHAFT(32)** through holes located on the **METER POST(31)**. Place a **PEDAL SPACER(33)** and a **PEDAL(34)** onto each end of the **PEDAL SHAFT(32)** and slide them toward the **METER POST(31)**. Then secure the **PEDALS(34)** with **BUTTON HEAD BOLTS(M8x1.25x15mm)(51)** and **LARGE WASHERS (M8)(36)** at both ends of the **PEDAL SHAFT(32)**. You need to use two Allen Wrenches to tighten the **BUTTON HEAD BOLTS(M8x1.25x15mm)(51)** at both ends of the **PEDAL SHAFT(32)** at the same time.

### STEP 5

Remove the **LOCKING KNOBS(13)** from the **PIVOT CONNECTOR(10)**.

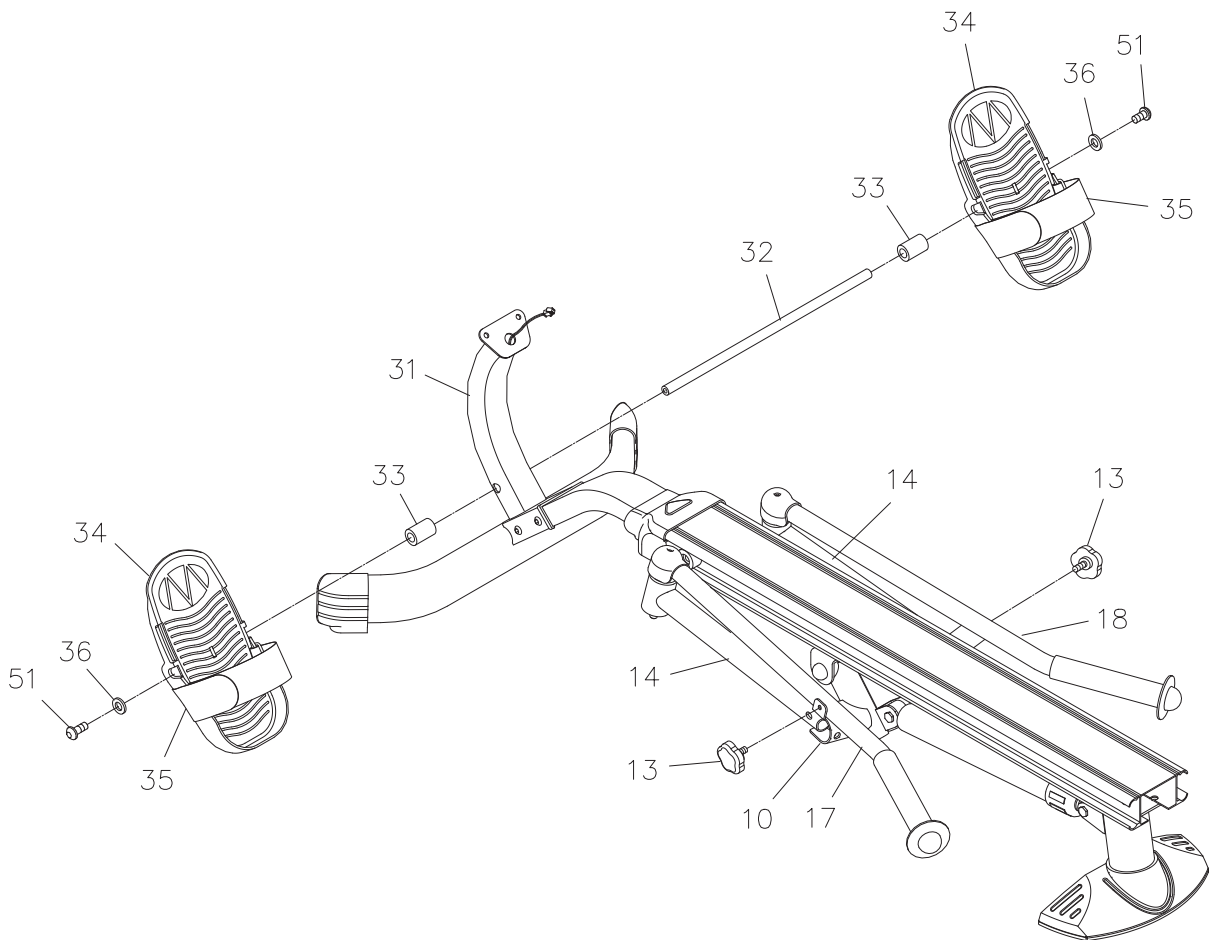

## ASSEMBLY INSTRUCTIONS

### STEP 6

Unfold the **HANDLEBARS(17, 18)** and the **EXTENSION ARMS(14)** as shown in the illustration. Attach the **EXTENSION ARMS(14)** to the **PIVOT CONNECTOR(10)** with the **LOCKING KNOBS(13)**.

### STEP 7

Install two AA batteries into the **METER(37)**, the batteries are not included. See page 12 for detailed battery installation instructions. Connect the **EXTENSION WIRE(39)** to the **METER(37)**. Attach the **METER(37)** to the plate on the **METER POST(31)** with **ROUND HEAD SCREWS(M5x0.8x12mm)(49)**.

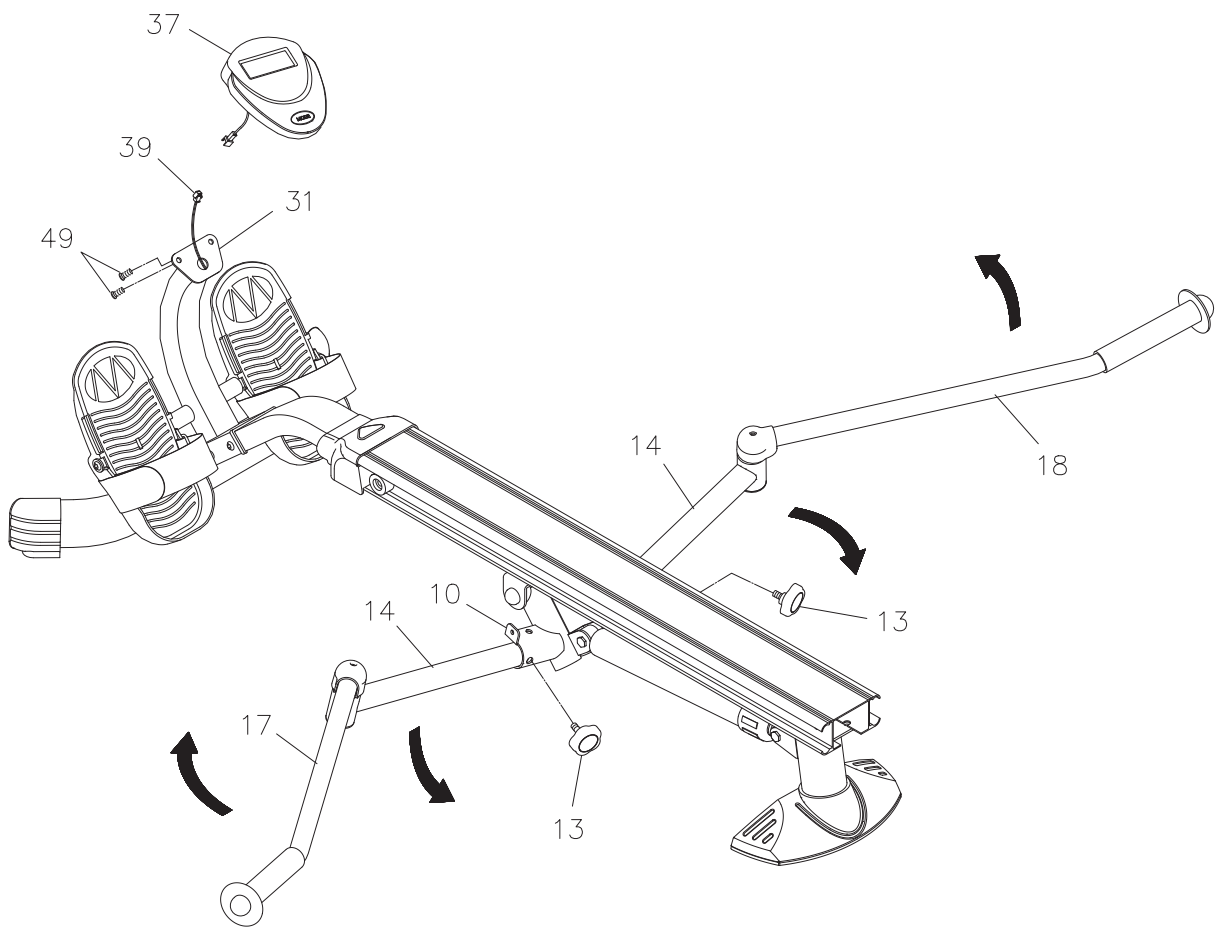

## ASSEMBLY INSTRUCTIONS

### STEP 8

Slide the **SEAT ASSEMBLY(42, 43)** onto the **CENTER BEAM(1)**. Attach the **SEAT STOPPERS(3)** to the back end of the **CENTER BEAM(1)** with **BUTTON HEAD BOLTS(M8x1.25x25mm)(53)**. Also, please verify that the other **SEAT STOPPERS(3)** at the front end of the **CENTER BEAM(1)** are assembled at the factory.

### STEP 9

Press the **CENTER BEAM CAP(2)** into the back end of the **CENTER BEAM(1)**.

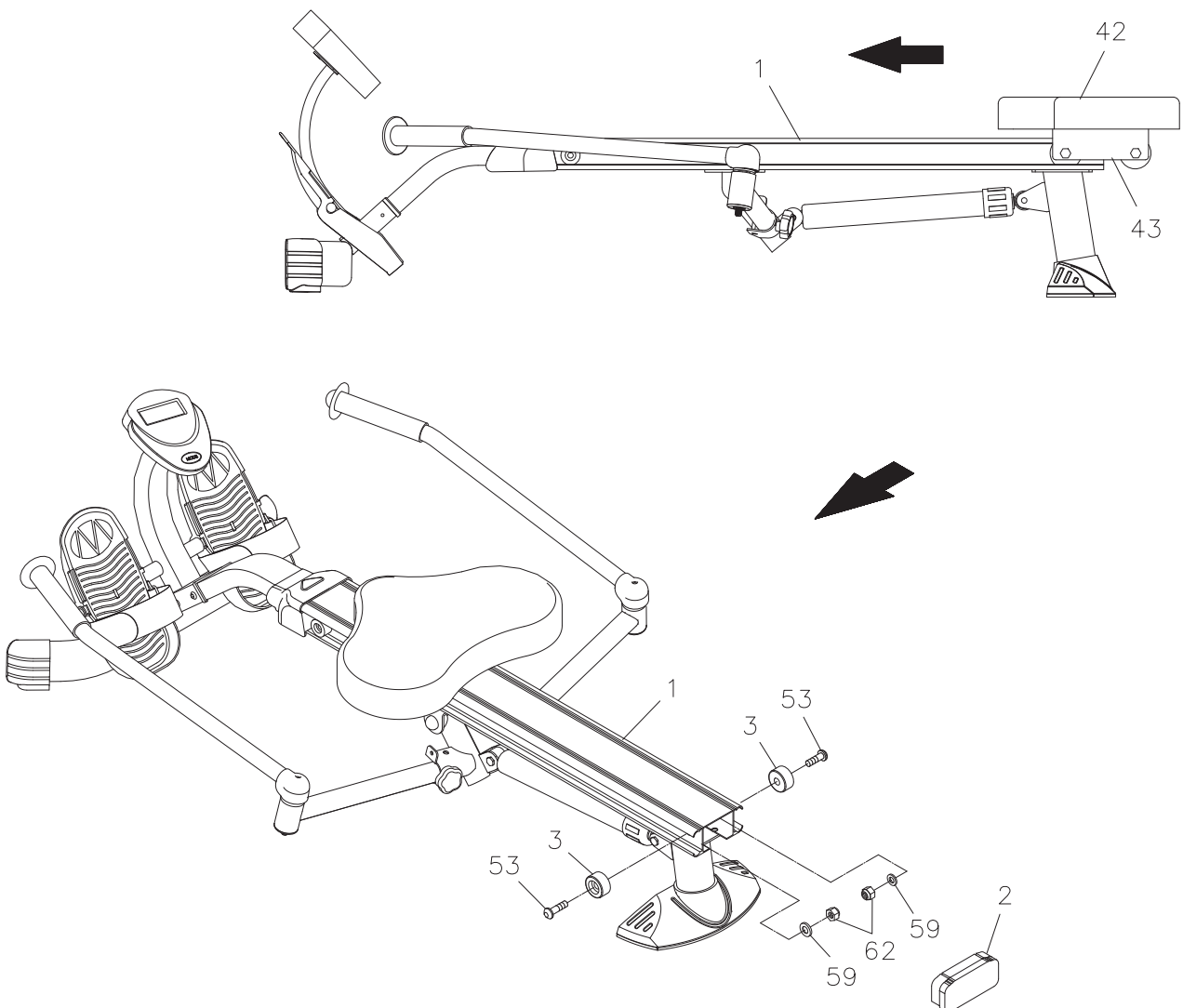

## OPERATIONAL INSTRUCTIONS

### USING THE FITNESS METER

**POWER ON :** Seat movement or press the button.

**POWER OFF :** Automatically shuts off after four minutes of inactivity.

#### MODE/RESET BUTTON:

Press to select display functions, including **SCAN**, **TIME**, **TOTAL COUNT**, **COUNT**, and **CALORIES**.

Press and hold for two seconds to reset all functions to zero, except **TOTAL COUNT**.

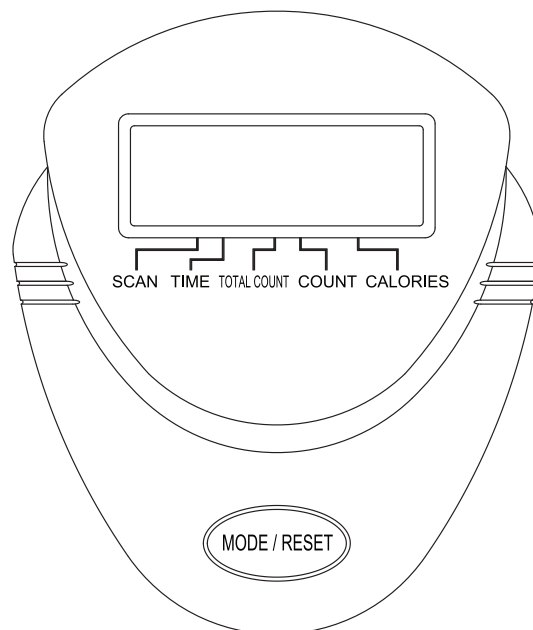

#### FUNCTIONS:

**SCAN:** Automatically scans each function of **TIME**, **TOTAL COUNT**, **COUNT**, and **CALORIES** in sequence with change every six seconds.

**TIME:** Displays the elapsed time from one second up to 99:59 minutes.

**TOTAL COUNT:** Displays the total accumulated number of rows you have taken, from zero to 9999 rows. The total accumulated rows is retained when the meter is turned off.

**COUNT:** Displays the total number of rows you have taken from zero to 9999 rows.

**CALORIES:** Displays the calorie burned from zero to 9999 Kcal. The calorie readout is an estimate for an average user. It should be used only as a comparison between workouts on this unit.

**NOTE:** The **TOTAL COUNT** will be reset to zero after batteries are removed for battery replacement or storage of the unit.

### HOW TO INSTALL AND REPLACE BATTERIES:

1. Open the Battery Door on the back of the meter.
2. The meter operates with two AA batteries, the batteries are not included. Refer to the illustration to install or replace the batteries.

- NOTE:**
1. Do not mix a new battery with an old battery.
  2. Use the same type of battery. Do not mix an alkaline battery with another type of battery.
  3. Rechargeable batteries are not recommended.
  4. **Ultimate disposal of battery should be handled according to all state and federal laws and regulations.**
  5. **Do not dispose of batteries in fire.**

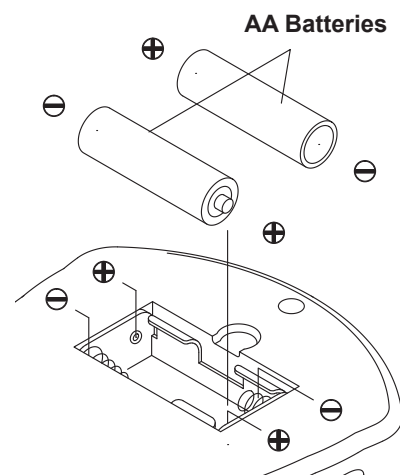

## OPERATIONAL INSTRUCTIONS

### LOAD ADJUSTMENT

The resistance of the shock can be adjusted by twisting the adjustment knob at the top of the shock. There are settings from 1 to 12. Setting #1 will provide the lowest resistance. Setting #12 will provide the highest resistance.

**CAUTION:** The shock gets **HOT** after a few minutes of use.

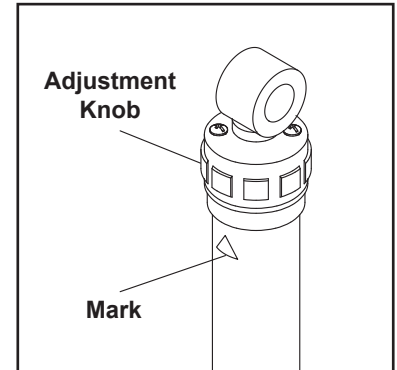

### PEDAL STRAP ADJUSTMENT

If you feel it is more comfortable for your workout, you can change to attach the **PEDAL STRAP(35)** to the upper position in the **PEDAL(34)** as shown in illustration 1 below. Run the **PEDAL STRAP(35)** through the opening from the bottom of the **PEDAL(34)**, then go through the Steel Ring. Slide the Steel Ring down to against the **PEDAL(34)**. Run the **PEDAL STRAP(35)** through the opening in the **PEDAL(34)** on the other side from the top as shown in the illustration 1, then make the end of the **PEDAL STRAP(35)** go up to attach onto the upper part of the **PEDAL STRAP(35)** with the Hook & Loop Pad.

Attach the end of the **PEDAL STRAP(35)** to different position with the Hook & Loop Pad to adjust the length. Refer to illustration 2.

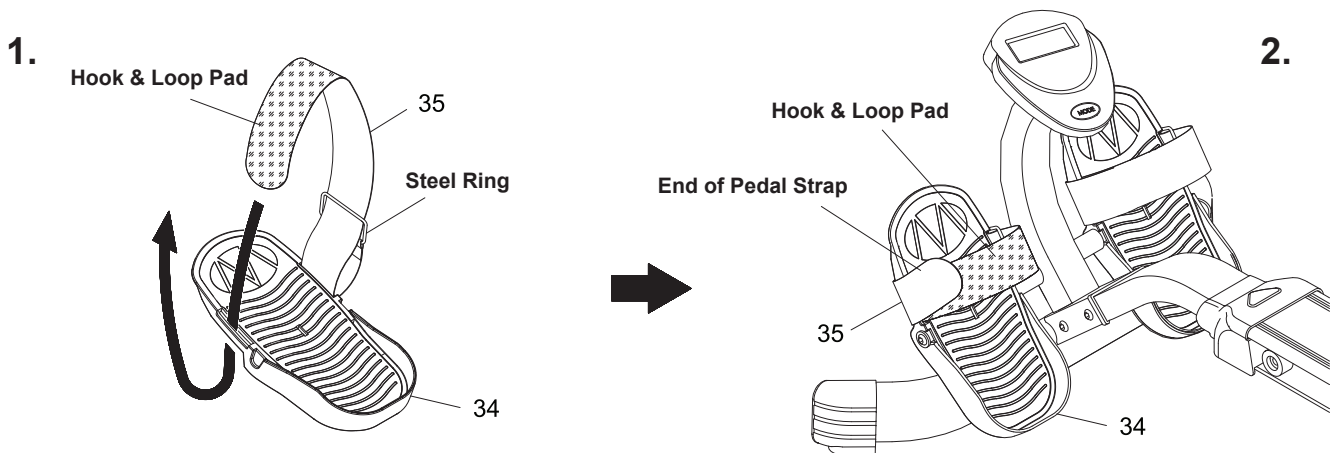

## MAINTENANCE

The safety and integrity designed into the **BodyTrac™ Glider** can only be maintained when the **BodyTrac™ Glider** is regularly examined for damage and wear. Special attention should be given to the following:

1. Pull on the **HANDLEBARS(17, 18)** and verify that the **SHOCK(22)** provides tension.
2. Clean the roller tracks in the **CENTER BEAM(1)** with an absorbent cloth.
3. Verify that all nuts and bolts are present and properly tightened. Replace missing nuts and bolts. Tighten loose nuts and bolts.
4. Verify that the **WARNING LABEL(67)** is in place and easy to read. Call Stamina Products immediately at 1-800-375-7520 for a replacement **WARNING LABEL(67)** if it is missing or damaged.
5. It is the sole responsibility of the user/owner to ensure that regular maintenance is performed.
6. Worn or damaged components shall be replaced immediately or the **BodyTrac™ Glider** removed from service until repair is made.
7. Only Stamina Products supplied components shall be used to maintain/repair the **BodyTrac™ Glider**.
8. Keep your **BodyTrac™ Glider** clean by wiping it off with an absorbent cloth after use.

## STORAGE

1. To store the **BodyTrac™ Glider**, simply keep it in a clean dry place.
2. Grasp the Front and Rear Stabilizer to move the **BodyTrac™ Glider**. Do not use the Seat to move the **BodyTrac™ Glider**. The Seat will move and the Seat Carriage may pinch your hand or fingers.
3. To avoid damage to the electronics, remove the batteries before storing the **BodyTrac™ Glider** for one year or more.

### Folding the BodyTrac™ Glider

Follow the following process to fold the **BodyTrac™ Glider** as illustrated for easy storage.

- A. Slide the **SEAT(42)** to the front end of the **CENTER BEAM(1)**. Remove the **LOCKING KNOBS(13)** from the **PIVOT CONNECTOR(10)**.
- B. Swing the **LEFT and RIGHT HANDLEBARS(17, 18)** backward. Then fold the **EXTENSION ARMS(14)** to the front.
- C. Lock the handlebars in the folded position by screwing the **LOCKING KNOBS(13)** onto the **PIVOT CONNECTOR(10)**. Now, you can store the **BodyTrac™ Glider** in the place you want.
- D. Refer to illustration D. You can stand the **BodyTrac™ Glider** on end for storage.

**NOTE:** Keep fingers clear of all pinch points when folding and unfolding the **BodyTrac™ Glider**.

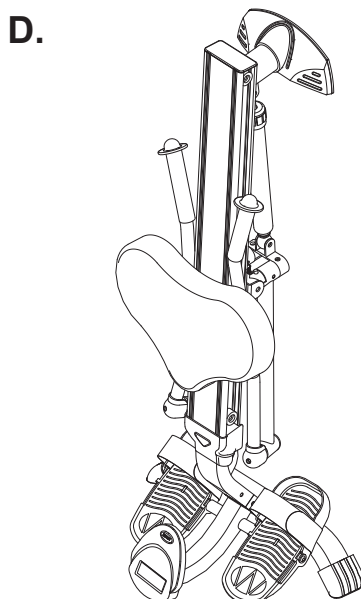
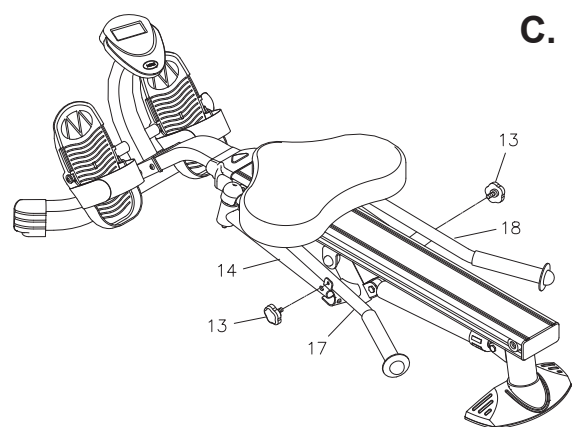
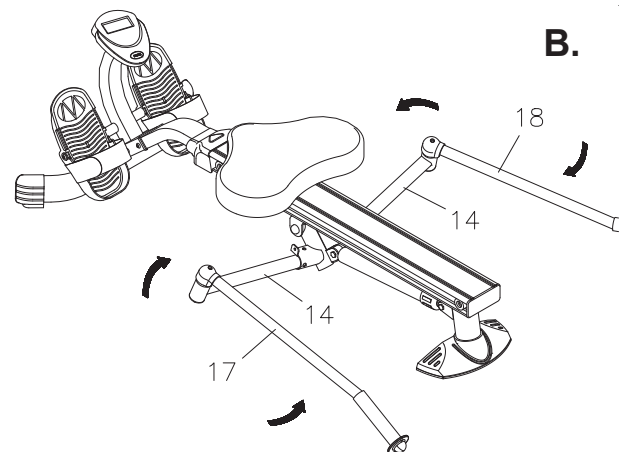
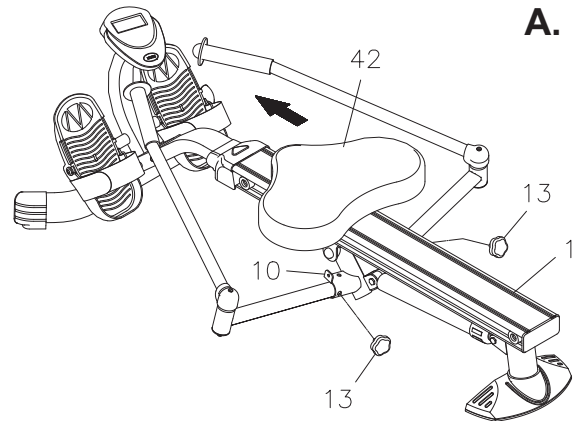

## CONDITIONING GUIDELINES

How you begin your exercise program depends on your physical condition. If you have been inactive for several years or are severely overweight, start slowly and increase your workout time gradually. Increase your workout intensity gradually by monitoring your heart rate while you exercise.

Remember to follow these essentials:

- Have your doctor review your training and diet programs.
- Begin your training program slowly with realistic goals that have been set by you and your physician.
- Warm up before you exercise and cool down after you work out.
- Take your pulse periodically during your workout and strive to stay within a range of 60% (lower intensity) to 90% (higher intensity) of your maximum heart rate zone. Start at the lower intensity, and build up to higher intensity as you become more aerobically fit.
- If you feel dizzy or lightheaded you should slow down or stop exercising.

Initially you may only be able to exercise within your target zone for a few minutes; however, your aerobic capacity will improve over the next six to eight weeks. It is important to pace yourself while you exercise so you don't tire too quickly.

To determine if you are working out at the correct intensity, use a heart rate monitor or use the table below. For effective aerobic exercise, your heart rate should be maintained at a level between 60% and 90% of your maximum heart rate. If just starting an exercise program, work out at the low end of your target heart rate zone. As your aerobic capacity improves, gradually increase the intensity of your workout by increasing your heart rate.

Measure your heart rate periodically during your workout by stopping the exercise but continuing to move your legs or walk around. Place two or three fingers on your wrist and take a six second heartbeat count. Multiply the results by ten to find your heart rate. For example, if your six second heartbeat count is 14, your heart rate is 140 beats per minute. A six second count is used because your heart rate will drop rapidly when you stop exercising. Adjust the intensity of your exercise until your heart rate is at the proper level.

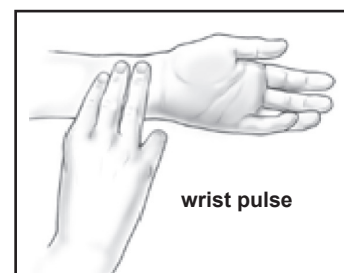

Target Heart Rate Zone Estimated by Age\*

Age	Target Heart Rate Zone (55%-90% of Maximum Heart Rate)	Average Maximum Heart Rate 100%
20 years	110-180 beats per minute	200 beats per minute
25 years	107-175 beats per minute	195 beats per minute
30 years	105-171 beats per minute	190 beats per minute
35 years	102-166 beats per minute	185 beats per minute
40 years	99-162 beats per minute	180 beats per minute
45 years	97-157 beats per minute	175 beats per minute
50 years	94-153 beats per minute	170 beats per minute
55 years	91-148 beats per minute	165 beats per minute
60 years	88-144 beats per minute	160 beats per minute
65 years	85-139 beats per minute	155 beats per minute
70 years	83-135 beats per minute	150 beats per minute

\* For cardiorespiratory training benefits, the American College of Sports Medicine recommends working out within a heart rate range of 55% to 90% of maximum heart rate. To predict the maximum heart rate, the following formula was used:  $220 - \text{Age} = \text{predicted maximum heart rate}$

## WARM-UP and COOL-DOWN

**Warm-Up** The purpose of warming up is to prepare your body for exercise and to minimize injuries. Warm up for two to five minutes before strength training or aerobic exercising. Perform activities that raise your heart rate and warm the working muscles. Activities may include brisk walking, jogging, jumping jacks, jump rope, and running in place.

**Stretching** Stretching while your muscles are warm after a proper warm-up and again after your strength or aerobic training session is very important. Muscles stretch more easily at these times because of their elevated temperature, which greatly reduces the risk of injury. Stretches should be held for 15 to 30 seconds. Do not bounce.

### Suggested Stretching Exercises

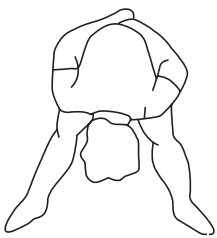

#### Lower Body Stretch

Place feet shoulder-width apart and lean forward. Keep this position for 30 seconds using the body as a natural weight to stretch the backs of the legs. **DO NOT BOUNCE!** When the pull on the back of the legs lessens, gradually try a lower position.

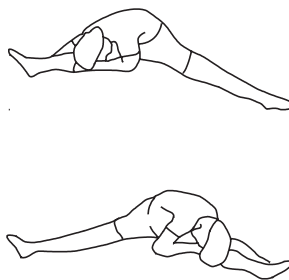

#### Floor Stretch

While sitting on the floor, open the legs as wide as possible. Stretch the upper body toward the knee on the right leg by using your arms to pull your chest to your thighs. Hold this stretch 10 to 30 seconds. **DO NOT BOUNCE!** Do this stretch 10 times. Repeat the stretch with the left leg.

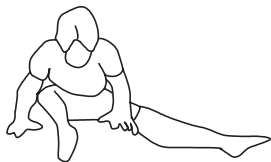

#### Bent Torso Pulls

While sitting on the floor, have legs apart, one leg straight and one knee bent. Pull the chest down to touch the thigh on the leg that is bent, and twist at the waist. Hold this position at least 10 seconds. Repeat 10 times on each side.



#### Bent Over Leg Stretch

Stand with feet shoulder-width apart and lean forward as illustrated. Using the arms, **gently** pull the upper body towards the right leg. Let the head hang down. **DO NOT BOUNCE!** Hold the position a minimum of 10 seconds. Repeat pulling the upper body to the left leg. Do this stretch several times slowly.

**Remember to always check with your physician before starting any exercise program.**

**Cool-Down** The purpose of cooling down is to return the body to its normal, or near normal, resting state at the end of each exercise session. A proper cool-down slowly lowers your heart rate and allows blood to return to the heart. Your cool-down should include the stretches listed above and should be completed after each strength training session.

## **WARRANTY**

Stamina Products, Inc. warrants that this product will be free from defects in materials and workmanship under normal use, service, proper assembly and proper operation for a period of 90 days on the parts and one year on the frame from the date of the original purchase from an authorized retailer. **THIS WARRANTY SHALL NOT APPLY TO ANY PRODUCT WHICH HAS BEEN SUBJECT TO COMMERCIAL USE, ABUSE, MISUSE, ALTERATION OF ANY TYPE OR CAUSE OR TO ANY DEFECT OR DAMAGE CAUSED BY IMPROPER ASSEMBLY, REPAIR, REPLACEMENT, SUBSTITUTION OR USE WITH PARTS OTHER THAN PARTS PROVIDED BY STAMINA PRODUCTS, INC.** Commercial use includes use of the product in athletic clubs, health clubs, spas, gymnasiums, exercise facilities, and other public or semipublic facilities whether or not the product's use is in furtherance of a profit making enterprise, and all other use which is not for personal, family, or household purposes.

To implement this limited warranty, send a written notice stating your name, date, and place of purchase and a brief description of the defect along with your receipt to **Stamina Products, Inc. P.O. Box 1071, Springfield Missouri, USA, 65801-1071**, or email us at **customer.care@staminaproducts.com**, or call us at **1-800-375-7520**. If the defect is covered under this limited warranty, you will be requested to return the product or part to us for free repair or replacement at our option. **NO ACTION FOR BREACH OF THIS LIMITED WARRANTY MAY BE COMMENCED MORE THAN ONE (1) YEAR AFTER THE DATE THE ALLEGED BREACH WAS OR SHOULD HAVE BEEN DISCOVERED. NO ACTION FOR BREACH OF ANY IMPLIED WARRANTY MAY BE COMMENCED MORE THAN ONE (1) YEAR AFTER DELIVERY OF THE PRODUCT TO THE PURCHASER.** This limited warranty is not transferable. **IF ANY PART OF THE PRODUCT IS NOT IN COMPLIANCE WITH THIS LIMITED WARRANTY OR ANY IMPLIED WARRANTY, THE REMEDY OF REPAIR OR REPLACEMENT IS THE EXCLUSIVE REMEDY AVAILABLE TO YOU.** In the event that the purchaser makes any claim under this limited warranty or any implied warranty, the Warrantor reserves the right to require the product to be returned for inspection, at the purchaser's expense, to the Warrantor's premises in Springfield, Missouri. Return of the enclosed warranty registration card is not required for warranty coverage, but is merely a way of establishing the date and place of purchase.

Stamina Products, Inc. **SHALL NOT BE LIABLE FOR THE LOSS OF USE OF ANY PRODUCT, LOSS OF TIME, INCONVENIENCE, COMMERCIAL LOSS OR ANY OTHER INDIRECT, CONSEQUENTIAL, SPECIAL OR INCIDENTAL DAMAGES DUE TO BREACH OF THE ABOVE WARRANTY OR ANY IMPLIED WARRANTY.**

This limited warranty is the only written or express warranty given by Stamina Products, Inc. This warranty gives you specific legal rights, and you may also have other legal rights which vary from state to state. **ANY OTHER RIGHT WHICH YOU MAY HAVE, INCLUDING ANY IMPLIED WARRANTY OR MERCHANTABILITY OR FITNESS FOR A PARTICULAR PURPOSE, IS LIMITED IN DURATION TO THE DURATION OF THIS WARRANTY.**

The laws in some jurisdictions restrict the rights of manufacturers and distributors of consumer goods to disclaim or limit implied warranties and consequential and incidental damages with respect thereto. If any such law is found to be applicable, the foregoing disclaimers and limitations of and on implied warranties and consequential and incidental damages with respect thereto shall be disregarded and shall be deemed not to have been made to the extent necessary to comply with such legal restriction.

# PRODUCT PARTS DRAWING

## FRONT

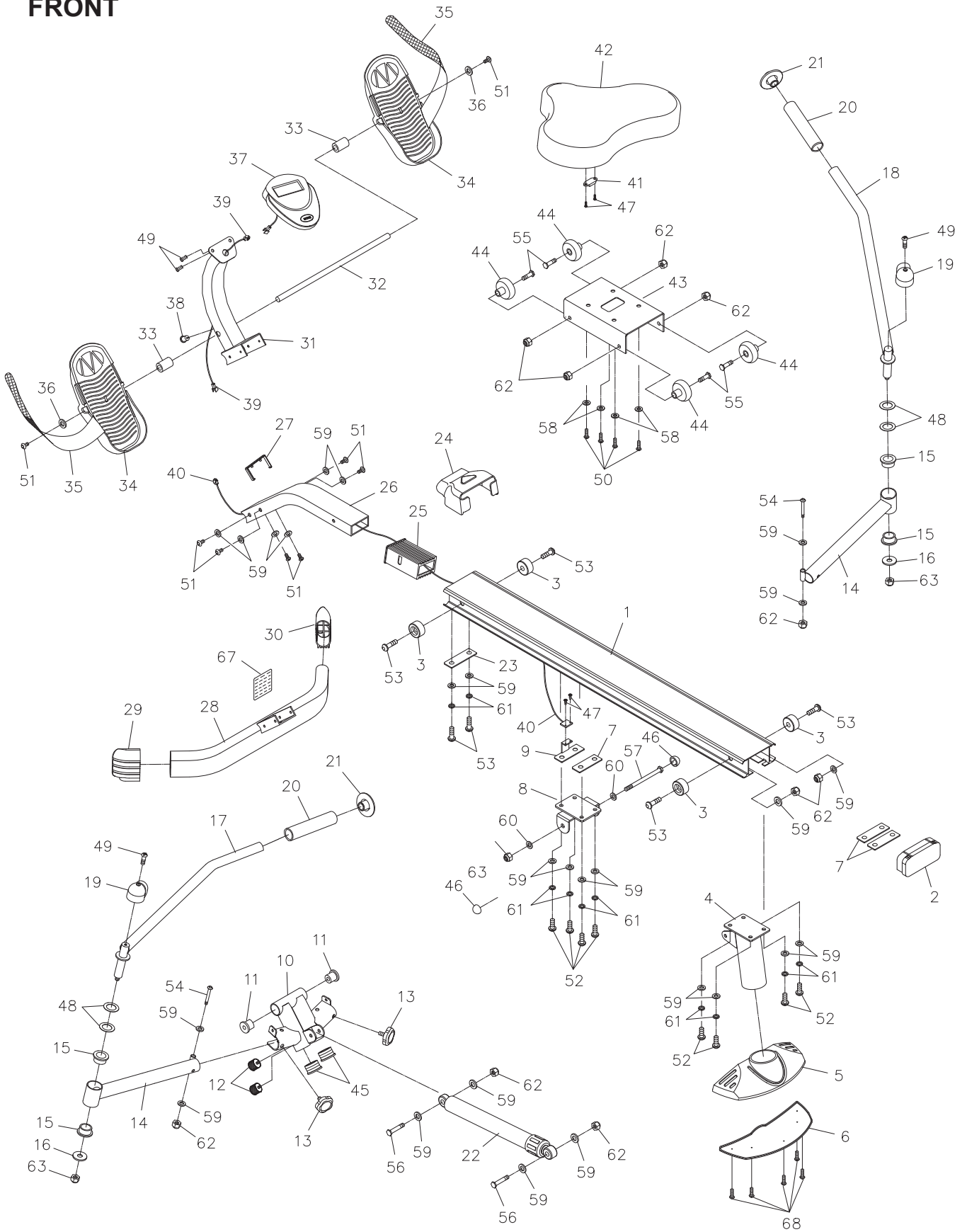

## BACK

## PARTS LIST

PART#	PART NAME	QTY
1	Center Beam	1
2	Center Beam Cap	1
3	Seat Stopper	4
4	Rear Support	1
5	Stabilizer Cap	1
6	Stabilizer Pad	1
7	Threaded Support Plate	3
8	Handlebar Support	1
9	Sensor Support Plate	1
10	Pivot Connector	1
11	Pivot Bushing	2
12	Bumper Knob	2
13	Locking Knob	2
14	Extension Arm	2
15	Extension Arm Bushing	4
16	Large Washer (M12)	2
17	Left Handlebar	1
18	Right Handlebar	1
19	Securing Cap	2
20	Foam Grip	2
21	Handlebar Cap	2
22	Shock	1
23	Support Plate	1
24	Front Cover	1
25	Sleeve	1
26	Front Support	1
27	Support Ring	1
28	Front Stabilizer	1
29	Left Stand Cap	1
30	Right Stand Cap	1
31	Meter Post	1
32	Pedal Shaft	1
33	Pedal Spacer	2
34	Pedal	2
35	Pedal Strap	2
36	Large Washer (M8)	2
37	Meter	1
38	Grommet	1
39	Extension Wire	1
40	Sensor Wire	1
41	Magnet	1
42	Seat	1
43	Seat Carriage	1
44	Roller	4
45	Round Plug (25mm)	2
46	Nut Cap (M10)	2
47	Screw, Round Head (M2.9 x 10mm)	4

## PARTS LIST

PART#	PART NAME	QTY
48	Wave Washer (ø20 x ø23.5 x 0.5mm thick)	4
49	Screw, Round Head (M5 x 0.8 x 12mm)	4
50	Bolt, Round Head (M6 x 1 x 15mm)	4
51	Bolt, Button Head (M8 x 1.25 x 15mm)	8
52	Bolt, Button Head (M8 x 1.25 x 20mm)	8
53	Bolt, Button Head (M8 x 1.25 x 25mm)	6
54	Bolt, Button Head (M8 x 1.25 x 50mm)	2
55	Bolt, Hex Head (M8 x 1.25 x 30mm)	4
56	Bolt, Hex Head (M8 x 1.25 x 41mm)	2
57	Bolt, Hex Head (M10 x 1.5 x 120mm)	1
58	Washer (M6)	4
59	Washer (M8)	26
60	Washer (M10)	2
61	Spring Washer (M8)	10
62	Nylon Nut (M8 x 1.25)	10
63	Nylon Nut (M10 x 1.5)	3
64	Allen Wrench (5mm)	2
65	Wrench (13mm)	1
66	Owner's Manual	1
67	Warning Label	1
68	Screw, Round Head (M3.5 x 15mm)	5

## **NOTES**

## TO CONTACT CUSTOMER CARE

For your convenience, Stamina's customer care representatives can be reached by email at [customer.care@staminaproducts.com](mailto:customer.care@staminaproducts.com) or by phone at 1-800-375-7520 (in the U.S.). Our customer care representatives are available Monday through Thursday from 7:30 a.m. until 5:00 p.m., and Friday 8:00 a.m. until 3 p.m. Central Time.



**ONLINE  
CUSTOMER CARE**  
customer.care@staminaproducts.com  
www.staminaproducts.com



**TELEPHONE  
CUSTOMER CARE**  
Tel: 1 (800) 375-7520



**FAX  
CUSTOMER CARE**  
Fax: (417) 889-8064



**MAIL**  
**STAMINA PRODUCTS, INC.**  
ATTN: Customer Care  
P.O. Box 1071 Springfield, MO. 65801-1071

Would you like to receive email information or special offers from Stamina Products? Register at [contact.staminaproducts.com](http://contact.staminaproducts.com)

## TO REGISTER YOUR PRODUCT

To enact your warranty, please register your product by going to [register.staminaproducts.com](http://register.staminaproducts.com). Please have your product model number (printed on the cover of this owner's manual) and the serial number (printed on the black and white sticker on your product) ready.

If you don't have internet access, you can call customer care at 1-800-375-7520, or fill out and mail the product registration form below to Stamina Products, Inc.; P.O. Box 1071; Springfield, MO 65801-1071.

<b>PRODUCT REGISTRATION FORM</b>	<b>Stamina Products, Inc.</b> P.O. Box 1071 Springfield, MO 65801-1071	
Model Number: .....	Serial Number: .....	
Product Name: .....		
Place Purchased: .....		
Date of Purchase: .....	Purchase Price: .....	
First Name: .....	Last Name: .....	
City: .....	State: .....	Zip Code: .....
Email Address: .....	Phone #: (     ) .....	
Would you like to receive email information or special offers from Stamina Products?* <input type="checkbox"/> Yes <input type="checkbox"/> No *If yes, be sure your email address is included above.		



Detach and Mail or Fax the Form Above



## TO ORDER PARTS

If there are missing or damaged parts, you can go to [parts.staminaproducts.com](http://parts.staminaproducts.com) and order those parts. If you have questions, please contact customer care. Do not return the product. To order parts by mail, fill out the sheet below and fax it to 417-889-8064. The part will be mailed to your address.



Detach and Mail or Fax the Form Below



<b>PARTS ORDER FORM</b>	<b>Stamina Products, Inc.</b> P.O. Box 1071 Springfield, MO 65801-1071	
Mr./Ms: .....		
Address: .....		
Apt. #: .....		
City: .....	State: .....	Zip Code: .....
<b>IMPORTANT : We must have your phone number to process the order!</b>		
Phone #: (     ) .....		Work Phone #: (     ) .....
Date of Purchase: .....		
Model #: .....		
Purchased From: .....		

**IMPORTANT : Before filling out the form below make sure you have the correct information.  
Refer to the parts list to make sure you're ordering the right parts!**

PART #	DESCRIPTION	QUANTITY
EXAMPLE: 1	Rear Unit Assembly	1