

Comfort, Quality & Style Since 1998



Performance Series LPG Patio Heater

Item#: 01775, 63713, 63714, 63715, 63716, 63717, 63718, 63719, 63720



DANGER

FOR YOUR SAFETY: If you smell gas:
1. Shut off gas to the appliance.
2. Extinguish any open flame.
3. If odor continues, keep away from the appliance and immediately call your gas supplier or fire department.

WARNING

Do not store or use gasoline or other flammable vapors and liquids in the vicinity of this or any other appliance. An LP-cylinder not connected for use shall not be stored in the vicinity of this or any other appliance.

DANGER

DANGER indicates an imminently hazardous situation which, if not avoided, will result in death or serious injury.

WARNING

Improper installation, adjustment, alteration, service or maintenance can cause property damage, injury or death. Read the installation, operation and maintenance instructions thoroughly before installing or servicing this equipment.

DANGER

Failure to comply with the precautions and instructions provided with this heater can result in death, serious bodily injury and property loss or damage from hazards of fire, explosion, burn, asphyxiation, and/or carbon monoxide poisoning. Only persons who can understand and follow the instructions should use or service this heater.

WARNING

FOR OUTDOOR USE ONLY!

WARNING

This product can expose you to chemicals including Carbon Monoxide, Lead, Chromium (hexavalent compounds), Di(2-ethylhexyl) phthalate (DEHP) and Diisononyl phthalate (DINP), which are known to the State of California to cause cancer and birth defects or other reproductive harm. For more information, go to www.P65Warnings.ca.gov.

WARNING

If your patio heater model is equipped with a base weight/sand box, it is strongly recommended that you fill it with sand or fine gravel and attach it securely to the bottom of the heater. In windy conditions, store the heater in a protected area or otherwise secure it. Unsecured heaters can be blown over in moderate to high wind. Damaged due to weather or acts of God is not covered under warranty.



ATTACH YOUR RECEIPT HERE

Keep a copy of your proof of purchase or order confirmation which will be needed if you need to contact us about warranty coverage.

Serial No. _____ Purchase Date _____



Questions, problems, missing parts?

Before returning to your retailer, our Florida-based customer service team is available.

Call toll-free **(866) 985-7877** 9 a.m. – 9 p.m., EST

Email **cservice@welltraveled.net**

Live chat **www.balkenehome.com** 9 a.m. – 6 p.m., EST., Monday – Friday



TABLE OF CONTENTS

Table of Contents	Page 2
Before You Begin	Page 2
Safety Information	Page 3
Package Contents & Hardware	Page 4
Assembly	Pages 5-7
Operating Instructions	Pages 8-11
Care and Maintenance	Page 12
Troubleshooting	Page 13
Warranty Information	Page 14



BEFORE YOU BEGIN

Please read and understand this entire manual before attempting to assemble, operate or install this appliance. If you have any questions regarding the product, please contact our Customer Service desk:

Call toll-free	(866) 985-7877	9 a.m. – 9 p.m., EST
Email	cservice@welltraveled.net	
Live chat	www.balkenehome.com	9 a.m. – 6 p.m., EST., Monday – Friday

This manual contains important information about the assembly, operation and maintenance of this patio heater. General safety information is presented in the first few pages and is also located throughout this manual. Keep this manual for future reference and to educate new users of this appliance. This manual should be read in conjunction with the labeling on the appliance. Safety precautions are essential when any mechanical or propane-fueled equipment is involved. These precautions are necessary when using, storing, and servicing. Using this appliance with the respect and caution demanded will reduce the possibilities of personal injury or property damage. The symbols shown on page 3 are used extensively throughout this manual. Always heed these precautions, as they are essential when using any mechanical or propane-fueled equipment.



 **DANGER**

DANGER indicates an imminently hazardous situation which, if not avoided, will result in death or serious injury.

 **DANGER**

EXPLOSION—FIRE HAZARD

- Keep solid combustibles, such as building materials, paper, or cardboard a safe distance away from the heater as recommended by the instructions.
- Provide adequate clearances around air openings into the combustion chamber.
- Never use the heater in spaces which do or may contain volatile or airborne combustibles, or products such as gasoline, solvents, paint thinner, dust particles, or unknown chemicals.
- During operation, this appliance can be a source of ignition. Keep heater area clear and free from combustible materials, gasoline, paint thinner, cleaning solvents and other flammable vapours and liquids. Do not use heater in areas with high dust content. Minimum heater clearances from combustible materials: 3 feet (36 inches) from top and 2 feet (24 inches) from sides.
- Never store propane near high heat, open flames, pilot lights, direct sunlight, other ignition sources or where temperatures exceed 120°F (49°C).
- Propane vapours are heavier than air and can accumulate in low places. If you smell gas, leave the area immediately.
- Never instal or remove a propane cylinder while the heater is lighted, near flame, pilot lights, or other ignition sources or while heater is hot to the touch.
- This heater is red hot during use and can ignite flammables too close to the burner. Keep flammables at least 3 feet (36 inches) from top and 2 feet (24 inches) from sides. Keep gasoline and other flammable liquids and vapours well away from heater.
- Store the propane cylinder outdoors in a well ventilated space out of the reach of children. Never store the propane cylinder in an enclosed area (house, garage, etc.). If heater is to be stored indoors, disconnect the propane cylinder for outdoor storage.

 **DANGER**

CARBON MONOXIDE HAZARD

- This heater is a combustion appliance. All combustion appliances produce carbon monoxide (CO) during the combustion process. This product is designed to produce extremely minute, non-hazardous amounts of CO if used and maintained in accordance with all warnings and instructions. Do not block the air flow into or out of the heater.
- Carbon Monoxide (CO) poisoning produces flu-like symptoms, water eyes, headaches, dizziness, fatigue, and possibly death. You can't see and you can't smell it. It is an invisible killer. If these symptoms are present during operation of this product, get fresh air immediately!
- For outdoor use only.
- Never use inside house or other unventilated or enclosed areas.
- This heater consumes air (oxygen). Do not use in unventilated or enclosed areas to avoid endangering your life.

 **WARNING**

WARNING indicates an imminently hazardous situation which, if not avoided, can result in death or serious injury.

 **WARNING**

BURN HAZARD

- Never leave heater unattended when hot or in use.
- Keep out of reach of children.

 **WARNING**

Certain materials or items, when stored under the heater, will be subject to radiant heat and could be seriously damaged.

 **WARNING:**

FOR OUTDOOR USE ONLY

 **CARBON MONOXIDE HAZARD**

This appliance can produce carbon monoxide which has no odor. Using it in an enclosed space can kill you. Never use this appliance in an enclosed space such as a camper, tent or home.

 **WARNING**

- This product is fueled by propane gas. Propane gas is invisible, odorless, and flammable. An odorant is normally added to help detect leaks and can be described as having a "rotten egg" smell. The odorant can fade over time so leaking gas is not always detectable by smell alone.
- Propane gas is heavier than air and leaking propane will sink to the lowest level possible. It can ignite by ignition sources including matches, lighters, sparks or open flames of any kind many feet away from the original leak. Use only propane gas set up for vapor withdrawal.
- Store to use propane gas in compliance with local ordinances and codes or with ANSI/NFPA 58. Turn off propane when not in use.
- Alert children and adults to the hazards of high surface temperatures. Stay away from these surfaces to avoid burning skin or igniting clothing.
- Carefully supervise young children when in the vicinity of the heater.
- Do not hang clothing or any other flammable materials from the heater, or place near the heater.
- Replace any guard or protective device removed for servicing the appliance prior to placing back in service.
- Installation and repair should be done by a qualified service person. The heater should be inspected before use and annually be a qualified service person. More frequent cleaning may be required as necessary. It is imperative that the control compartment, burners, and circulating air passageway of the appliance be kept clean.

 **CAUTION**

CAUTION indicates an imminently hazardous situation which, if not avoided, may result in minor or moderate injury, or property damage.

 **CAUTION**

SERVICE SAFETY

- Keep all connections and fittings clean. Make sure propane cylinder valve outlet is clean.
- During set up, check all connections and fittings for leaks using soapy water, never use a flame to check for leaks.
- Use as a heating appliance only. Never alter in any way to use with any device.

PACKAGE CONTENTS

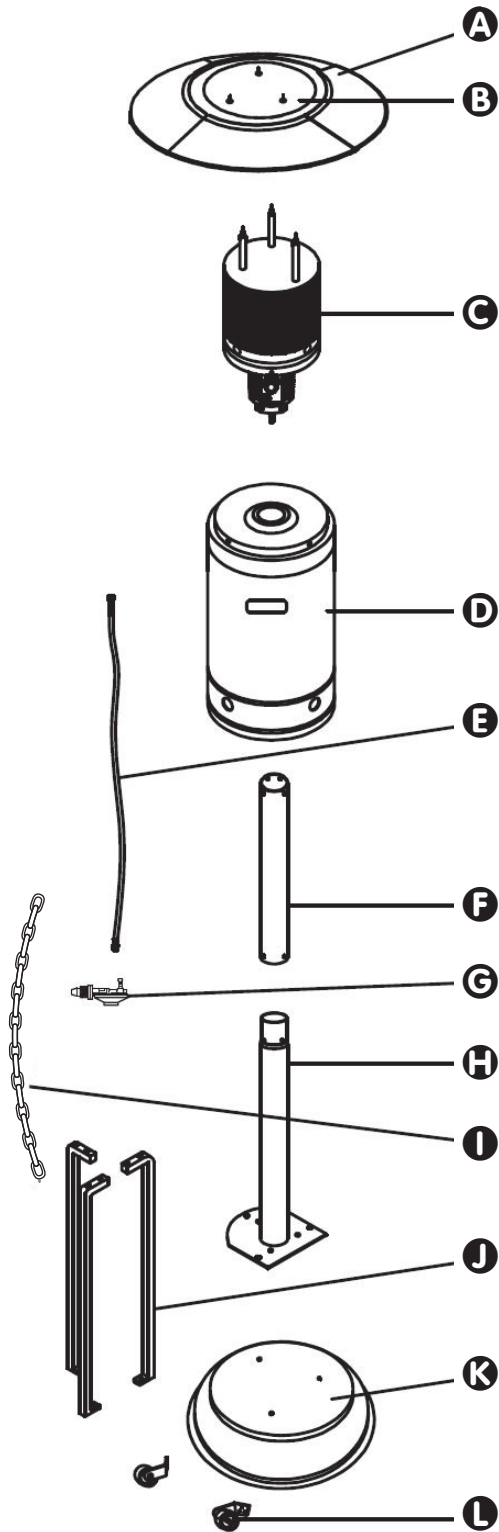









PART	DESCRIPTION	QUANTITY
A	Reflector Panel	4pcs (packed in 2 inner ctns)
B	Reflector Center Cap	1
C	Head Assembly	1 (packed in 1 inner ctn)
D	Tank Housing	1
E	Gas Hose	1 (attached to Head Assembly)
F	Upper Post	1
G	Regulator	1 (packed with Head Assembly)
H	Lower Post	1
I	LPG Tank Chain	1
J	Post Supports	3 (packed in inner ctn)
K	Base*	1
L	Wheels	2 (packed with Head Assembly)

Base* Some models come with a base weight sandbox feature. See page 5 for details on sandbox assembly.

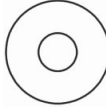

HARDWARE CONTENTS

			
M	N	O	P
M8x16 Bolt Qty: 4 <i>Pre-assembled to Base</i>	M6x16 Bolt Qty: 6 <i>Pre-assembled to Base</i>	M6x22 Bolt Qty: 6	M6 Nut Qty: 6
			
Q	R	S	T
M8 Wing Nut Qty: 3	M6x12 Bolt / M6 Lock Washer Qty: 4 <i>Pre-assembled in Head</i>	M8 Washer Qty: 3	M6 Washer Qty: 12



PREPARATION

Before beginning assembly of this appliance, make sure all parts are present. Compare all parts with package contents list and hardware contents as listed on page 4 of this manual. If any part is missing or damaged, do not attempt to assemble this product. Contact customer service for replacement parts.

ESTIMATED ASSEMBLY TIME: 60 minutes

Tools Required for Assembly (NOT included): Phillips screwdriver w/medium blade, Leak Detection Solution, Adjustable wrench (2)
(Note: 10mm wrench or socket should fit M6 bolt; 13mm wrench or socket should fit M8 bolt.)

NOTE: This heater has an Electronic Ignition and will require installation of 1 – AAA battery. The battery should be installed by unscrewing the RED IGNITER BUTTON.

***Sandbox:** For models that come with a sandbox, it will be pre-assembled to the base. To fill the sandbox, remove the central **Large Bolt** and **Nut** that secure the base to the sandbox. Lift the **Base K** off the sandbox and remove the plastic cap on the outer edge of the top of the sandbox. Fill the sandbox with water (ONLY if the heater will not be exposed to freezing temperatures) or sand. Replace the plastic cap. Insert the **Bolt** through the **Base** and replace the **Spacer Tube** and **Washer**, then re-attach the sandbox to the **Base** and secure with the **Nut**. You may find it easier to fill the sandbox prior to attaching wheels.

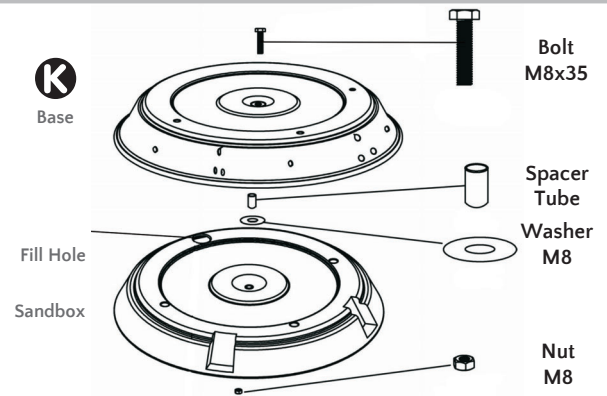

1 Attach **Wheels L** to **Base K**. Align holes in **Wheel Bracket** with corresponding holes in **Base**, and insert 3 **M6x16 Bolts N** through holes and finger-tighten. Repeat with second **Wheel**. Tighten with wrench once both **Wheels** have been attached. **Note: 6 - M6x16 Bolts N come pre-assembled to the base. You will need to loosen and remove them to complete this assembly.**

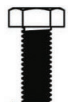
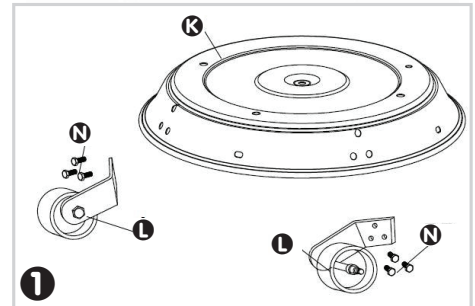

Hardware Used: 6x Bolt M6x16

2 Attach the **Post Supports J** to the **Base K**. Align the holes in the bottom of each **Post Support** with the hole on the **Base**. Insert 1 **M8x16 Bolt M** through the hole in the support and into the **Base** and hand tighten. Repeat with the other 2 **Post Supports** and then tighten all bolts with a wrench. **Note: 3 - M8x16 Bolts M come pre-assembled to the base. You will need to loosen and remove them to complete this assembly.**

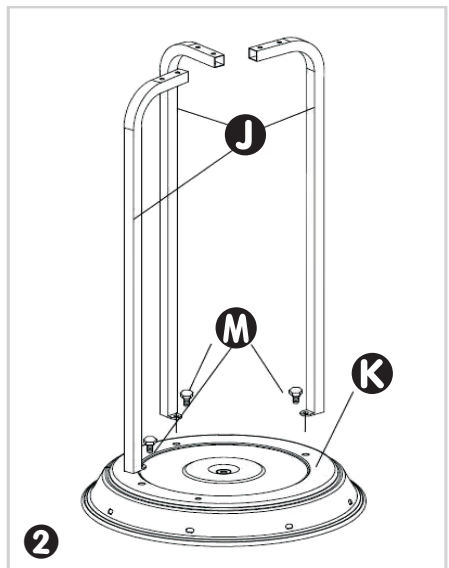

Hardware Used: 3x Bolt M8x16

ASSEMBLY



3 Attach the **Lower Post** **H** to the **Post Supports** **J**. Once you have tightened the bolts holding the **Post Supports** **J** to the **Base** **K**, align the holes in the **Lower Post** **H** with the holes on the tops of the **Post Supports** **J** and insert a **M6x22 Bolt** **O** through a **M6 Washer** **I** and then through the hole in the **Post Support**. Place another **M6 Washer** onto the bottom of the **M6x35 Bolt** and secure with a **M6 Nut** **P**. Repeat this in the 5 remaining holes (6 holes total—2 for each **Post Support** piece). Hand-tighten initially, then tighten with a wrench after all bolts have been inserted.

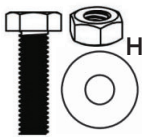

Hardware Used: 6x Bolt M6x22
12x Washer M6
6x Nut M6

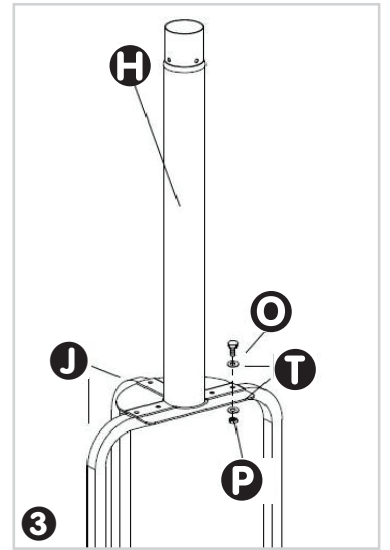

4 Attach **Upper Post** **F** to **Lower Post** **H** by screwing the two pieces of the post together.

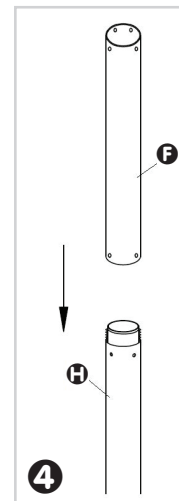

5 Place **Tank Housing** **D** onto **Base** **K**. Slide **Tank Housing** **D** over the assembled **Upper/Lower Post** and down over the **Post Supports**. Rest **Tank Housing** on **Base**.

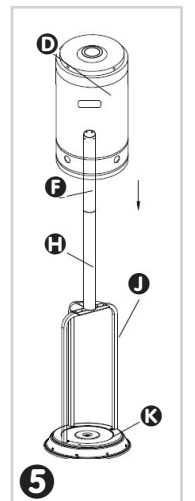

6 Attach **Head Assembly** **C** to **Upper Post** **F**. *Note: There is a small piece of protective foam located in the neck of the Head Assembly that MUST be removed prior to attaching Head Assembly to the Upper Post.* Loosen and remove the 4 **Bolts with Lock Washers** **R** pre-installed in the neck of the **Head Assembly**. Route **Gas Hose** **E** down into **Upper/Lower Post Assembly** and align 4 small holes on **Head Assembly** with 4 small holes in **Upper Post**. [HINT: Control knob should be centered above decal on post.] Insert 4 **M6x12** **R** bolts through 4 **M6 Lock Washers** **R**, then into holes and tighten.



Hardware Used: 4x M6x12 Bolt / M6 Lock Washer

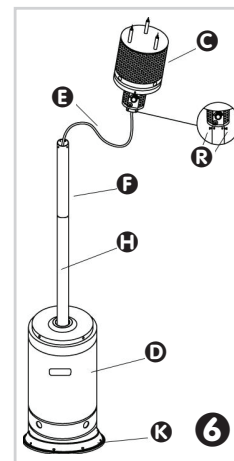



7 Assemble Reflector. **NOTE: Remove blue protective film from all pieces before Assembly!** Reflector Panels **A** come packaged in two brown boxes with two panels in each box. Hardware for assembly is already affixed to each panel. Place two panels side by side and remove the two cap nuts and washers that are affixed to one panel. Insert the affixed bolts into the open holes on the adjacent panel. Place the washer over the bolt and screw on cap nut. Repeat these steps until all four panels are assembled. Then locate the **Reflector Center Cap**. You will need to remove the cap nuts and washers located at the top of each Reflector Panel to allow assembly of the Center Cap on each panel. Align the holes in the Center Cap with the bolts on each panel and affix washer and cap nut to complete assembly.

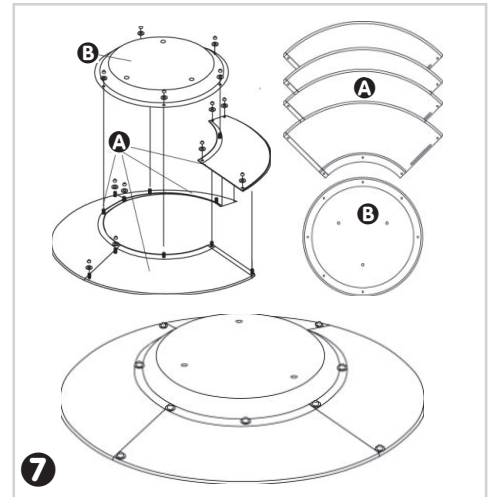

8 While supporting heater, tilt the **Head Assembly C** and slide the assembled **Reflector** over the 3 bolts that extend from the **Head Assembly**. Use the 3 **M8 Wing Nuts Q** and 3 **M8 Washers S** to secure the assembled **Reflector** to the **Head Assembly** of the heater. Once you have tightened the **Wing Nuts**, return the heater to an upright position.

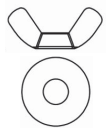

Hardware Used: 3x M8 Wing Nut
3x M8 Washer

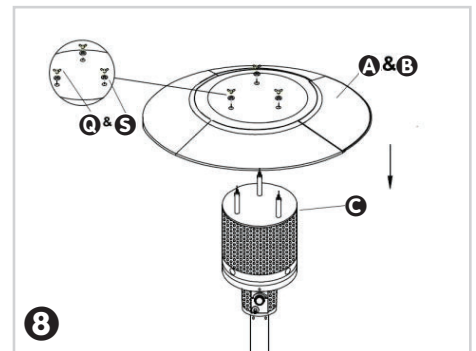

9 Connect the **Gas Hose** and **Regulator** to the LP cylinder. The LP cylinder is sold separately. Use a standard 20 lb. propane cylinder only. Lift the **Tank Housing D** up and rest it on the top of the assembled **Post Supports I**. Screw **Regulator G** onto **Gas Hose E**. Do not cross-thread. Hand-tighten securely. Attach **Regulator G** to valve on LP cylinder and hand-tighten securely. Place LP tank onto base of heater and secure **LP Tank** on base by hooking **Tank Chain I** onto the **Post Supports I**. Lower the **Tank Housing**. **NOTE: Use this heater only with a propane vapor withdrawal supply system. See chapter 5 of the standard for storage and handling of liquefied petroleum gas, ANSI/NFPA 58. Your local library or fire department should have this book.**

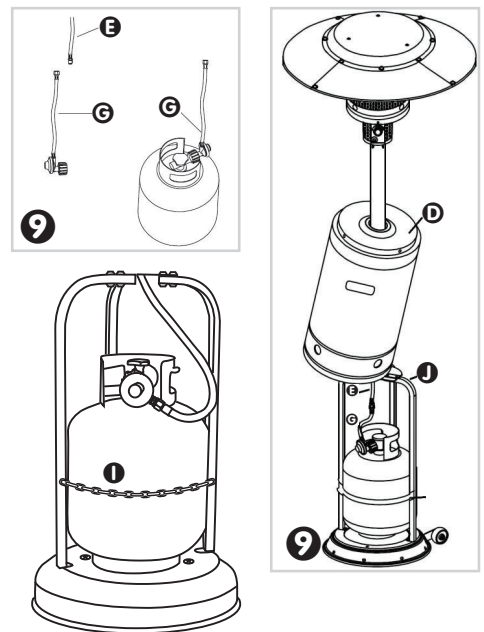

OPERATING INSTRUCTIONS



A dented, rusted or damaged propane cylinder may be hazardous and should be checked by your cylinder supplier. Never use a propane cylinder with a damaged valve connection.

The propane cylinder must be constructed and marked in accordance with the specifications for LPG cylinders of the U.S. Department of Transportation (DOT) or the standard for cylinders, spheres and tubes for transportation of dangerous goods and commission, CAN/CSA-B339.

The cylinder must be equipped with a listed over-filling prevention device.

The cylinder must have a connection device compatible with the connection for the appliance.

The cylinder used must include a collar to protect the cylinder valve.

Never connect an unregulated propane cylinder to the heater.

Attach regulator to cylinder. Complete attachment.

Secure the propane cylinder with the cylinder screw by tightening the screw until it comes in contact with the cylinder.

- Do not store a spare LPG cylinder under or near this appliance;
- Never fill the cylinder beyond 80 percent full;
- Place the dust cap on the cylinder valve outlet whenever the cylinder is not in use. Only install the type of dust cap on the cylinder valve that is provided with the cylinder valve. Other types of caps or plugs may result in leakage of propane.

Keep children away during assembly. This item contains small parts which can be swallowed by children.

Do not use indoors or inside any enclosure.

Retain the assembly instructions for future reference.

Installer - Please leave these instructions with the owner.

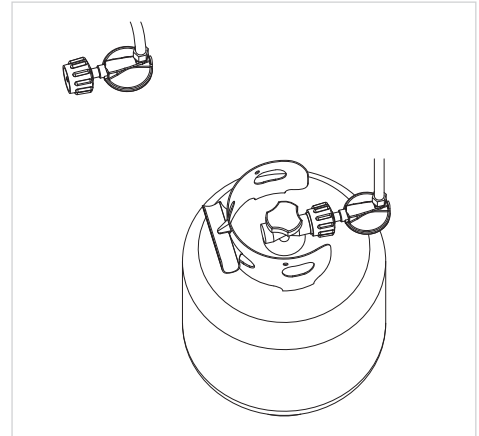

WARNING

FOR YOUR SAFETY

Be careful when attempting to manually ignite this heater. Holding in the control knob for more than 10 seconds before igniting the gas will cause a ball of flame upon ignition.

WARNING

FOR YOUR SAFETY

Heater will be hot after use. Handle with care.



LEAK TEST

1. Make 2–3 oz. of leak test solution (one part liquid dish washing detergent and three parts water).
2. Apply several drops of solution where hose attaches to regulator.
3. Apply several drops of solution where regulator connects to cylinder.
4. Make sure all patio heater valves are OFF.
5. Turn cylinder valve ON.

WARNING

- Perform all leak tests outdoors.
- Extinguish all open flames.
- NEVER leak test when smoking
- Do not use heater until all connections have been leak tested and show no signs of leakage.

IF BUBBLES APPEAR AT ANY CONNECTION, THERE IS A LEAK.

1. Turn cylinder valve OFF.
2. If leak is detected at hose/regulator connection, tighten connection and perform another leak test. If bubbles continue to appear, call our customer service hotline at **(866) 985-7877**, 9 a.m. – 9 p.m., EST.
3. If leak is detected at regulator/cylinder valve connection, disconnect, reconnect, and perform another leak test. If you continue to see bubbles after several attempts, cylinder valve is defective. Call our customer service hotline at **(866) 985-7877**, 9 a.m. – 9 p.m., EST.

IF NO BUBBLES APPEAR AT ANY CONNECTION, THE CONNECTIONS ARE SECURE.

Note: *Whenever gas connections are loosened or removed, you must perform a complete leak test.*

WARNING: **FOR OUTDOOR USE ONLY**

CARBON MONOXIDE HAZARD

This appliance can produce carbon monoxide which has no odor. Using it in an enclosed space can kill you. Never use this appliance in an enclosed space such as a camper, tent or home.

Caution: *Do not attempt to operate this appliance until you have read and understand all Safety Information in this manual and all assembly is complete and leak tests have been performed.*

BEFORE TURNING GAS SUPPLY ON:

1. Your heater was designed and approved for **OUTDOOR use only**. Do NOT use it inside a building, garage, or any other enclosed area.
2. Make sure surrounding areas are free of combustible materials, gasoline, and other flammable vapors or liquids.
3. Ensure that there is no obstruction to air ventilation. Be sure all gas connections are tight and there are no leaks.
4. Be sure the cylinder cover is clear of debris. Be sure any component removed during assembly or servicing is replaced and fastened prior to starting.

BEFORE LIGHTING:

1. Heater should be thoroughly inspected before each use, and by a qualified service person at least annually. If re-lighting a hot heater, always wait at least 5 minutes.
2. Inspect the hose assembly for evidence of excessive abrasion, cuts, or wear. Suspected areas should be leak tested. If the hose leaks, it must be replaced prior to operation. Only use the replacement hose assembly specified by the manufacturer.

OPERATING INSTRUCTIONS



CAUTION

Do not attempt to operate until you have read and understand all General Safety Information in this manual and all assembly is complete and leak test has been performed.

BEFORE TURNING GAS SUPPLY ON:

1. Your heater was designed and approved for OUTDOOR use only. Do NOT use it inside a building, garage, or any other enclosed area.
2. Make sure surrounding areas are free of combustible materials, gasoline, and other flammable vapors or liquids.
3. Ensure that there is no obstruction to air ventilation. Be sure all gas connections are tight and there are no leaks.
4. Be sure the cylinder cover is clear of debris. Be sure any component removed during assembly or servicing is replaced and fastened prior to starting.

BEFORE LIGHTING:

1. Heater should be thoroughly inspected before each use, and by a qualified service person at least annually. If re-lighting a hot heater, always wait at least 5 minutes.
2. Inspect the hose assembly for evidence of excessive abrasion, cuts, or wear. Suspected areas should be leak tested. If the hose leaks, it must be replaced prior to operation. Only use the replacement hose assembly specified by the manufacturer.

LIGHTING:

NOTE: For initial start or after any cylinder change, hold the control knob in for 2 minutes to purge air from all gas lines before proceeding.

NOTE: This heater has an Electronic Ignition and will require installation of 1 – AAA battery. The battery should be installed by unscrewing the RED IGNITER BUTTON.

1. Turn the control knob to the "OFF" position (large flame on knob turned to 9 o'clock position).
2. Fully open the LP cylinder valve.
3. Turn the control knob until the calibration mark aligns halfway between the small flame and the large flame symbols.
4. Depress the control knob, then push the RED igniter button to ignite the main burner. Hold until burner ignites, then release igniter. Continue to depress control knob for 30 seconds after ignition, then release.
5. To increase the flame, turn the control knob clockwise toward the large flame symbol. To decrease the flame, turn the control knob counter-clockwise towards the small flame symbol.
6. To turn the heater OFF, depress the control knob and turn clockwise to the OFF position (large flame turned toward 9 o'clock).
7. Wait at least 5 minutes before attempting to re-light the heater.
8. Turn the gas cylinder valve to OFF or closed.

For ignition problems, please consult "Troubleshooting" page of this manual.

CAUTION: avoid inhaling fumes emitted from the heater's first use. Smoke and odor from the burning of oils used in manufacturing will appear. Both smoke and odor will dissipate after approximately 30 minutes. The heater should NOT produce thick black smoke.



WARNING

Very hot while in operation!

Never lean over the heater while in use. Do not touch the Burner Assembly while the heater is in operation. Wait until the heater has cooled down after use before moving or touching any surfaces. Failure to comply with these instructions may result in serious bodily injury.



DANGER! FOR OUTDOOR USE ONLY



CARBON MONOXIDE HAZARD

Never use this inside a house, or other unventilated or enclosed areas. This heater consumes air (oxygen). Do not use in unventilated or enclosed areas to avoid endangering your life.

WHEN HEATER IS ON:

Emitter screen will become bright red due to intense heat. The color is more visible at night. Burner will display tongues of blue and yellow flame. These flames should not produce thick black smoke, indicating an obstruction of airflow through the burners. The flame should be blue with straight yellow tops. If excessive flame is detected, turn off heater and consult "Troubleshooting" page.

RE-LIGHTING:

Note: For your safety, control knob cannot be turned OFF without first depressing the control knob and then rotating to OFF.

1. Turn control knob to OFF.
2. Wait at least 5 minutes to allow gas to dissipate before re-lighting.
3. Repeat the "Lighting" steps.

SHUT DOWN:

1. Turn control knob clockwise to OFF while depressing the knob. (Normally, burner will make a slight popping noise when extinguished).
2. Turn cylinder valve clockwise to OFF and disconnect regulator when heater is not in use. **NOTE:** After use, some discoloration of the emitter screen is normal.

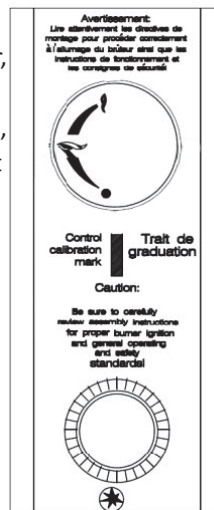



OPERATION CHECKLIST:

For a safe and pleasant heating experience, perform this check before each use:

BEFORE OPERATING:

- I am familiar with entire owner's manual and understand all precautions noted.
- All components are properly assembled, intact and operable.
- No alterations have been made.
- All gas connections are secure and do not leak.
- Wind velocity is below 10 mph.
- Heater is for use outdoors (outside any enclosure).
- There is adequate fresh air ventilation.
- Heater is away from gasoline or other flammable liquids or vapors.
- Heater is away from windows, air intake openings, sprinklers and other water sources.
- Heater is at least 36 in. on top and at least 24 in. on sides from combustible materials.
- Heater is on a hard and level surface.
- There are no signs of spider or insect nests in heater orifices.
- All burner passages are clear.
- All air circulation passages are clear.
- Clothing or other protective material should not be hung from the heater, or placed on or near the heater.
- Any guard or other protective device removed for servicing the heater must be replaced prior to operating the heater.
- Installation and repair should be done by a qualified service person. The heater should be inspected before each use and at least annually by a qualified service person.

OPERATION INFORMATION & SAFETY:

- Unit will operate at reduced efficiency below 40° F.
- Children and adults should be alerted to the hazards of high surface temperatures and should stay away to avoid burns or clothing ignition.
- Young children should be carefully supervised when they are in the area of the heater.
- More frequent cleaning may be required as necessary. It is imperative that control compartment burner and circulating air passageways of the heater be kept clean and free of debris and/or spider or insect nests.

OPERATION INFORMATION AND

SAFETY:

- Unit will operate at reduced efficiency below 40°F.
- Children and adults should be alerted to the hazards of high surface temperatures and should stay away to avoid burns or clothing ignition.
- Young children should be carefully supervised when they are in the area of the heater.
- More frequent cleaning may be required as necessary. It is imperative that control compartment burner and circulating air passageways of the heater be kept clean and free of debris and/or spider or insect nests.



AFTER OPERATION:

1. Gas control knob is in OFF position.
2. Gas tank valve is OFF.
3. Disconnect gas line.



To enjoy years of outstanding performance from your heater, make sure you perform the following maintenance activities on a regular basis:

Keep exterior surfaces clean.

1. Use soapy water for cleaning. Never use flammable or corrosive cleaning agents.
2. While cleaning your unit, be sure to keep the area around the burner and control compartment dry at all times. Do not submerge the control valve assembly. If the gas control is submerged in water, do NOT use it. It must be replaced.
3. Air flow must be unobstructed. Keep controls, burner, and circulating air passageways clean. Signs of possible blockage include:
 - Gas odor with extreme yellow tipping of flame.
 - Heater does NOT reach the desired temperature.
 - Heater glow is excessively uneven.
 - Heater makes popping noise.
 - Spiders and insects can nest in burner or orifices. This dangerous condition can damage heater and render it unsafe for use. Clean burner holes by using a heavy-duty pipe cleaner. Compressed air may help clear away smaller particles.
 - Carbon deposits may create a fire hazard. Clean dome and burner screen with warm soapy water if any carbon deposits develop.

Note: In a salt-air environment (such as near an ocean), corrosion occurs more quickly than normal. Frequently check for corroded areas and repair them promptly.

SERVICE:

Only a qualified service person should repair gas passages and associated components.

Caution: Always allow heater to cool before attempting service.



WARNING

FOR YOUR SAFETY

- Do NOT touch or move heater for at least 45 minutes after use.
- Burner and housing are hot to the touch.
- Allow burner and housing to cool before touching.

STORAGE:

Between uses:

- Turn control knob OFF.
- Disconnect LP source.
- Store heater in an area sheltered from direct contact with inclement weather (such as rain, sleet, hail, snow, dust and debris).
- If desired, cover heater to protect exterior surfaces and to help prevent build-up in air passages. Never leave LP cylinder exposed to direct sunlight or excessive heat. **Note:** *Wait until heater is cool before covering.*

During periods of extended inactivity or when transporting:

- Turn control knob OFF.
- Disconnect LP source and move to a secure, well-ventilated location outdoors.
- Store product in an area sheltered from direct contact with inclement weather (such as rain, sleet, hail, snow dust and debris).
- If desired, cover product to protect exterior surfaces and to help prevent build-up in air passages. Never leave LP cylinder exposed to direct sunlight or excessive heat.

Note: Wait until heater is cool before covering.



PROBLEM	POSSIBLE CAUSE	CORRECTIVE ACTION
Main burner will not light	Gas valve may be off	Turn gas valve ON
	Fuel tank may be empty	Refill LPG tank
	Orifice blocked	Clean or replace orifice
	Air in supply system	Purge air from lines: open gas lines and depress control knob for 2-3 minutes. Allow gas to dissipate before attempting to light.
	Loose connection	Check all fittings
	Igniter fails	Use stick lighter to manually light
	Gas pressure low with valve open full	Replace cylinder or regulator
	New cylinder or 1st ignition	Purge air from lines
	Cylinder valve on, no gas flow	Replace hose/regulator assembly
	Dead igniter battery	Replace battery by unscrewing igniter button
Low burner flame	Pressure is low	Replace LPG tank
	Tank is low on fuel	Fill LPG tank
	Gas hose is kinked	Check and straighten or replace
Burner unit	Carbon on reflector and emitter screen	Clean components as needed
	Thick black smoke	Blockage in burner assembly—thoroughly clean burner



Questions, problems, missing parts?

Before returning to your retailer, our exceptional customer service is available.

Call toll-free **(866) 985-7877** 9 a.m. – 9 p.m., EST
 Email **cservice@welltraveled.net**
 Live chat **www.balkenehome.com** 9 a.m. – 6 p.m., EST., Monday – Friday



by

BALKENE
—HOME—



LIMITED WARRANTY

Customers in the Contiguous US

With proof of purchase from an authorized retailer, this product is warranted for a period of 1 year from original purchase date against defects in materials and workmanship under normal use. This warranty does NOT cover normal wear/weathering, exposure to water, freezing temperatures, oils, fluids, or chemicals OR use in a commercial context if the unit is not designated as a commercial model. At Well Traveled Living's sole discretion, products under warranty will be repaired and/or replaced at no charge to the customer. Returns sent back to Well Traveled Living must be sent via prepaid freight in the original retail packaging.

For warranty service, contact Well Traveled Living at the address, phone numbers or website and email listed in this owner's manual. Be sure to have your sales receipt, date of purchase and catalogue/model numbers available when calling. All warranty service will be coordinated by Well Traveled Living's, Amelia Island, Florida service center. This warranty is extended only to the original owner. Proof of purchase will be required before warranty service is rendered. The sales receipt is the only valid proof of purchase. This warranty only covers failures due to defects in materials or workmanship which occur during normal use. Failures and/or damage which result from accident, negligence, misuse, abuse, neglect, mishandling, alteration or modification, failure to maintain, improper assembly or maintenance, service by unauthorized agency or use of unauthorized components or damage that is attributable to acts of God are NOT covered.

This limited warranty gives you specific legal rights and you may also have other rights which vary from jurisdiction to jurisdiction. The provisions of the United Nations Convention on Contracts for the Sales of Goods shall not apply to this limited warranty or the sale of products covered by this limited warranty.

- THERE ARE NO EXPRESS WARRANTIES EXCEPT AS LISTED.
- PURCHASER ASSUMES ALL RISKS IN THE ASSEMBLY AND OPERATION OF THIS UNIT.
- FAILURE TO FOLLOW WARNINGS AND OPERATIONAL INSTRUCTIONS CONTAINED IN THIS MANUAL CAN RESULT IN SEVERE PROPERTY DAMAGE AND/OR PERSONAL INJURY.
- IN NO EVENT WILL WELL TRAVELED LIVING, OR ITS DIRECTORS, OFFICERS OR AGENTS BE LIABLE TO THE PURCHASER OR ANY THIRD PARTY, WHETHER IN CONTRACT, IN TORT, OR ON ANY OTHER BASIS, FOR ANY INDIRECT, SPECIAL, PUNITIVE, EXEMPLARY, CONSEQUENTIAL, OR INCIDENTAL LOSS, COST, OR DAMAGE ARISING OUT OF OR IN CONNECTION WITH THE SALE, MAINTENANCE, USE, OR INABILITY TO USE THE PRODUCT, EVEN IF WELL TRAVELED LIVING OR ITS DIRECTORS, OFFICERS OR AGENTS HAVE BEEN ADVISED OF THE POSSIBILITY OF SUCH LOSSES, COSTS OR DAMAGES, OR IF SUCH LOSSES, COSTS, OR DAMAGES ARE FORESEEABLE. IN NO EVENT WILL WELL TRAVELED LIVING, OR ITS OFFICERS, DIRECTORS, OR AGENTS BE LIABLE FOR ANY DIRECT LOSSES, COSTS OR DAMAGES THAT EXCEED THE PURCHASE PRICE OF THE PRODUCT.
- SOME JURISDICTIONS DO NOT ALLOW THE EXCLUSION OR LIMITATION OF INCIDENTAL OR CONSEQUENTIAL DAMAGES, SO THE ABOVE LIMITATION OR EXCLUSION MAY NOT APPLY TO THE PURCHASER.

EXTEND YOUR WARRANTY

When you purchase a Fire Sense or Balkene Home product from any authorized retailer, you'll have peace of mind in knowing that it comes with a one-year warranty. Extend your warranty for *an additional year* when you review your item at balkenehome.com within 365 days of purchase.



Important Notice

Do NOT return to place of purchase—for customer service and warranty issues:

Call toll-free (866) 985-7877

9 a.m. – 9 p.m., EST

Email cservice@welltraveled.net

Live chat balkenehome.com

9 a.m. – 6 p.m., EST, Monday – Friday

Distributed by:

Well Traveled Living

716 S 8th Street, Amelia Island, FL 32034

balkenehome.com

cservice@welltraveled.net

(866) 985-7877