

# Flsun S1

Instruction Manual

Ultra High-Speed 3D Printing

1. Do not operate the machine according to methods other than those specified in the manual to avoid possible injury or property damage.
2. Do not place the printer near flammable, explosive or high heat sources, make sure that the printer is in a cool, dust free and well ventilated area.
3. Be careful touching the print bed, print nozzle, or other high temperature areas during or soon after use to avoid severe burns.
4. Do not reach inside the print area while the machine is in use to avoid injury from high speed movements.
5. Do not allow children or persons who have not read the instructions in detail to operate it alone to avoid personal injury or property damage.
6. Routine maintenance should be performed on the printer to ensure a long service life. The printer should be powered off before maintenance is performed, especially important on working parts such as the effector module and guide rails.
7. In case of an emergency during printing, press and hold the on/off button for 1.5 seconds to stop the printer, and then turn off the power.
8. If the printer is not going to be used for an extended period of time unplug the power cord.
9. Each printer is thoroughly tested before leaving the factory to ensure quality and functionality. It is normal to find evidence of prior use.
10. Visit the official FLSUN Wiki for more tutorials on machine use and maintenance: <http://wiki.flsun3d.com/en/home>.

PRODUCT		FLSUN S1
Printing Technology		Fused Deposition Modeling (FDM)
Printing Accuracy		±0.1mm
Recommended Layer Height		0.1-0.35mm
Chassis	Build Volume	∅320 * 430mm
	Frame	Full Metal
Dimensions	Product Dimensions	550*595*1030mm
	Package Dimensions	640*680*1120mm
	Net Weight	41kg
	Gross Weight	51kg
Effector	Extruder	Dual-Gear Direct Drive Extruder
	Nozzle	Hardened Steel
	Nozzle MAX Temp	350°C
	Nozzle Diameter	0.4mm
	Filament Diameter	1.75mm
Motor	Motor Types	36V Closed-loop motor
	Motor Calibration	Support
Bed	Build Plate	Textured PEI Print Plate
	Bed MAX Temp	120°C
	Smart Zone Heating	Inner Circle ∅220mm, Outer Ring 220-320mm
Materials	Supported	PLA, PETG, TPU, ABS, ASA, PVA, PET, PA, PC, PLA-CF etc.
	Drying	Separate Heating elements, Desiccant
Cooling	Fan	CPAP turbofan 40000 rpm
Speed	MAX Speed	1200mm/s
	MAX Acceleration	40000mm/s²
	MAX Flow	110mm³/s PLA
PSU	Input	110-240V, 50/60HZ
	Power	1300W@220V, 600W@110V

Electronics	Display	Full-Integration Touchscreen
	Storage	16GB EMMC,32GB USB Flash
	Control interface	Touchscreen, PC Interface
	CPU	Quad-Core ARM A7 1.5 GHz
	NPU	2 tops
Camera	Pixels	1920 × 1080 pixels
	Real-time Monitoring	Support
	Time-lapse Photography	Support
Sensors	Remaining Filament Weight	Dynamic Monitoring
	Filament Detection	Support
	Filament Clog Detection	Support
	Vibration Compensation	Support
	Auto-Leveling	Support
AI Lidar Detection	First Layer Detection	Support
	Accuracy Calibration	Support
	Flow Calibration	Support
AI Features	Debris Detection	Support
	Spaghetti Detection	Support
Energy Efficiency	Screen auto sleep	Support
	Printer auto power off	Support
	Smart Zone Heating	Support
	Power Off Resume Print Module	Support (Z lift, protect model)
	Air Filter	Composite filter: HEPA + Activated Carbon
System Upgrade	Upgrade Method	OTA
Software	Slicer	Flsun Slicer, Third-Party Slicers
	Supported OS	MacOS, Windows
	File Format	STL、OBJ、AMF、3MF

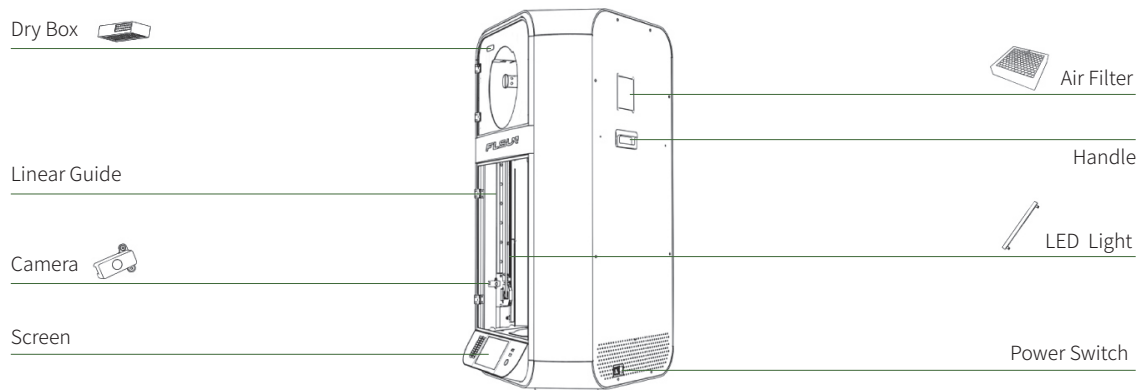
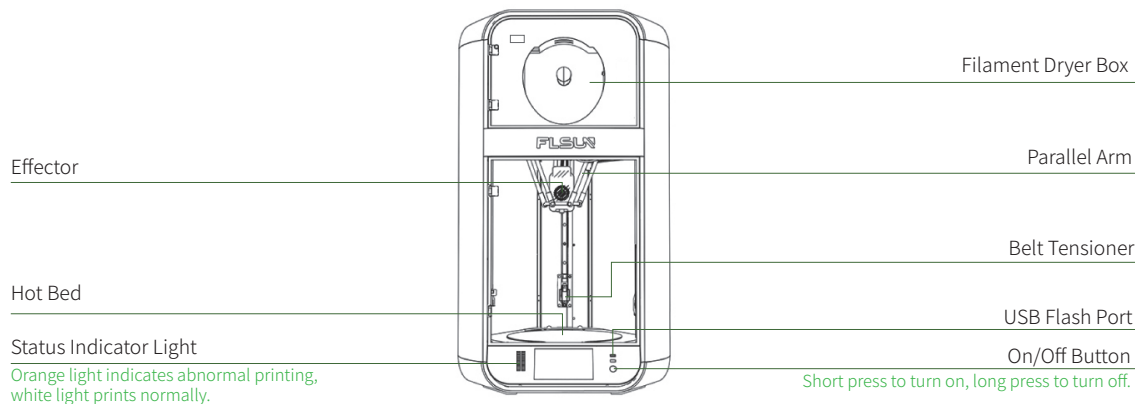

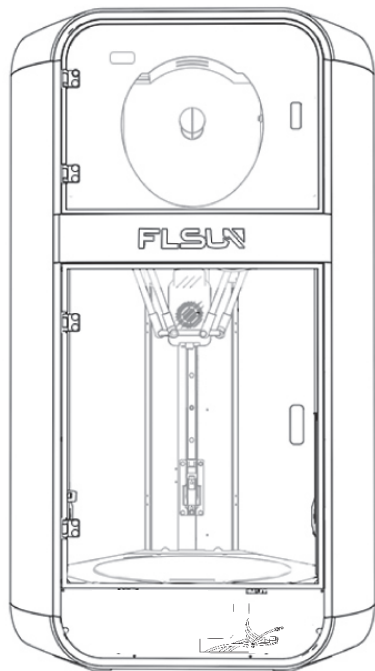

Flsun S1



500g PLA-HS



Screen Module



Service Policy



Power Cord



Accessory Box



Instruction Manual



door handles (x2)



Diagonal Plier



Silver Needle

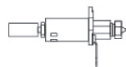

Hotend Kit

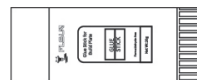

Glue Stick

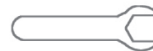

Open-end Wrench



USB Flash



Socket Wrench



Wrench Set



Grease



PTFE Tube

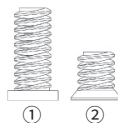

M3\*12 (×2) screws  
M3\*6 (×2) countersunk  
head screws  
For fixing the screen



Customized screws  
with spacers  
For fixing glass doo

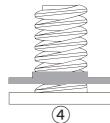

ST2.9\*6 (×4) screws  
with spacers  
For fixing the door handle

1

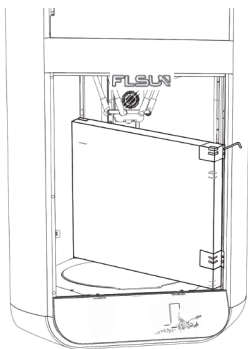

Remove the screws securing the glass door box and remove the box;

2

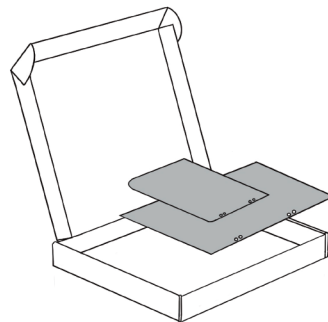

Remove the upper and lower glass doors from the box;

3

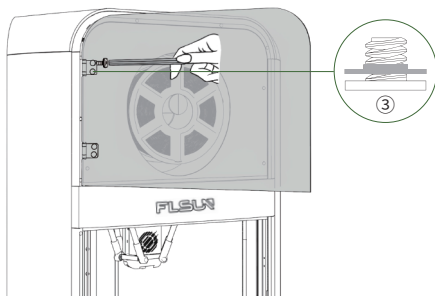

Install the upper glass door with ③ customized screws;

\*Gently tighten the screws

4

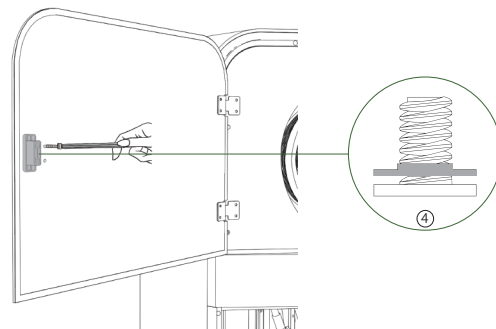

Use ④ST2.9\*6 screws to install the upper glass door handle ;

5

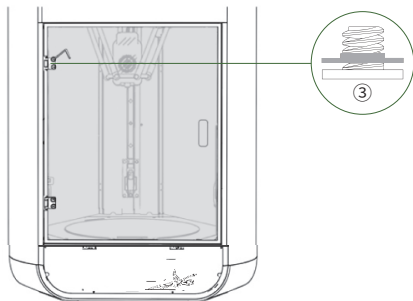

Install the lower glass door using ③ customized screws;

6

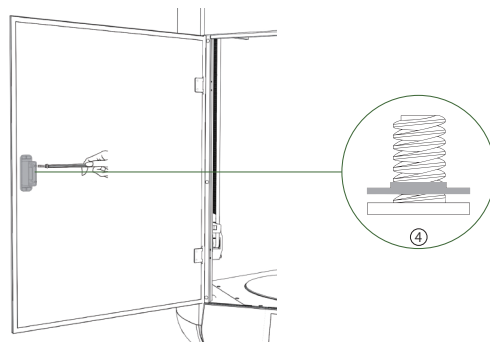

Install the lower glass door handle using the ④ST2.9\*6 screws;

7

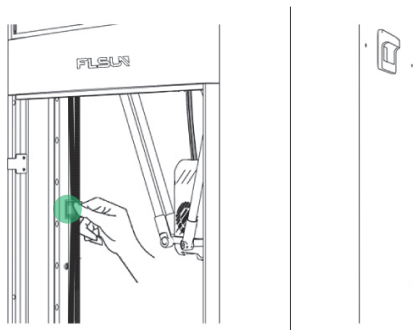

Remove the clips from the three belts to unlock the sliders.

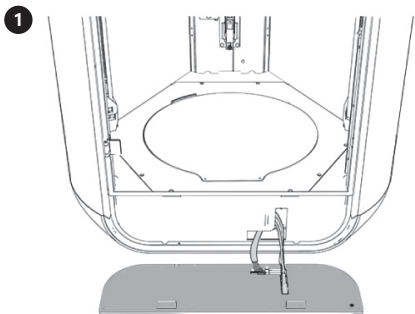

1 Remove the tape securing the wiring harness and plug the display power cable and the three data cables into the corresponding connection ports;

\*The three USB cables are connected by the number.

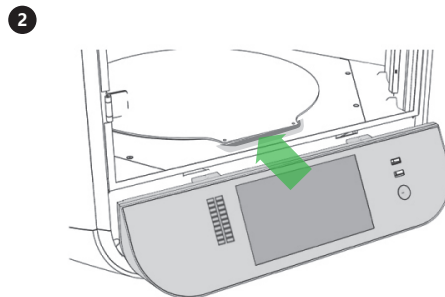

2 Insert the screen horizontally into the printer slot;

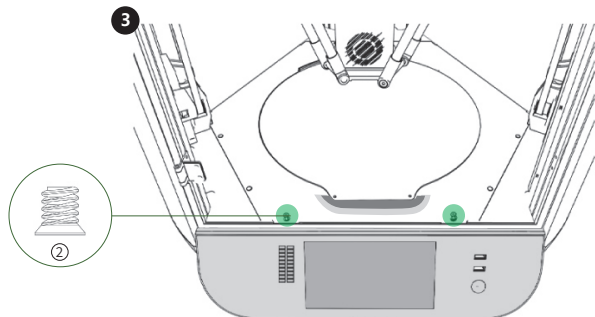

3 Secure the top of the screen using the M3\*6 screws included in the accessory box;

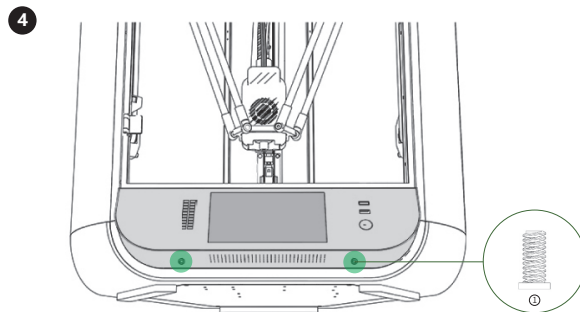

4 Secure the underside of the screen using the M3\*12 screws included in the accessory box.

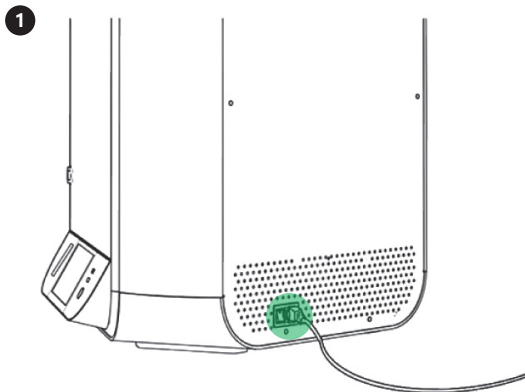

Connect the power cord to the right side of the printer. Press the power switch. The switch will light indicating it is in standby mode.

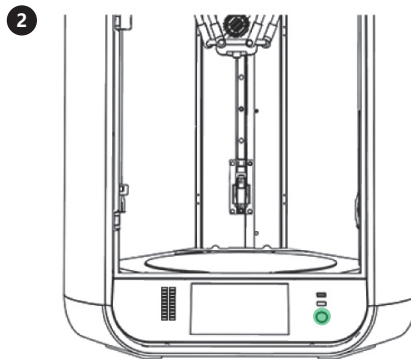

Press the power on/off button to turn on the printer.

\*In case of an emergency while the printer is operating, press and hold the on/off button for 1.5 seconds to stop the printer. If you turn off the power first, the printer will activate the UPS, delay power outage, and the printer will continue to run briefly.

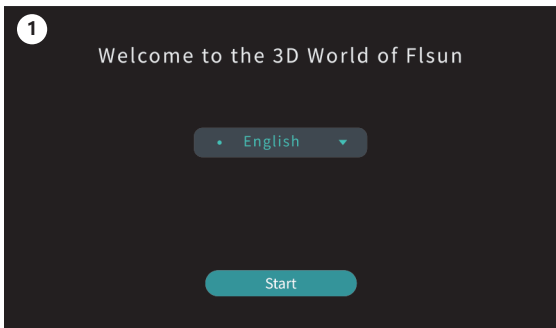

Please click “▼”;

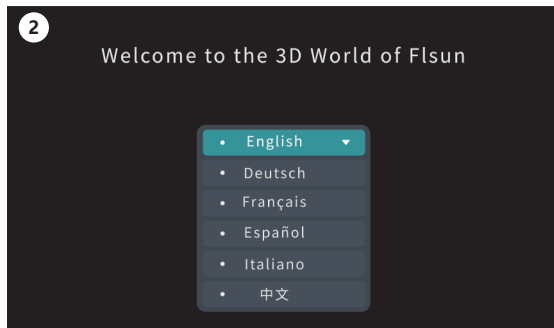

Please select the language and start using the printer.

## WiFi Settings

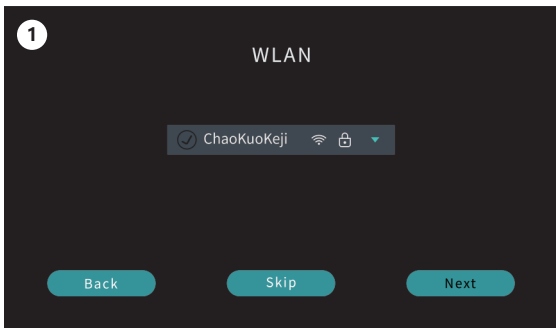

Please click “▼” to select the wireless network,you want to connect to;

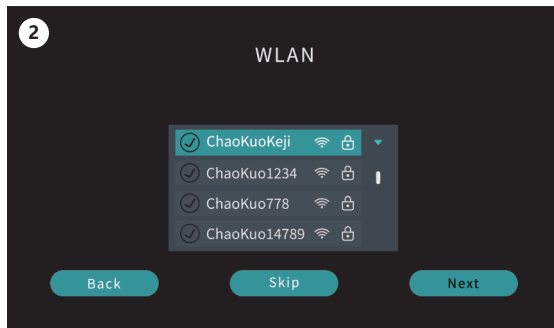

Unable to click "Next" during setup of network connection;

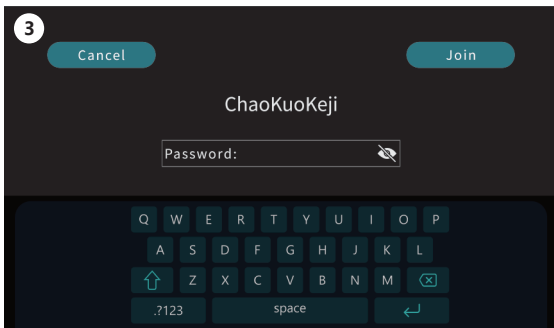

Enter WiFi password;

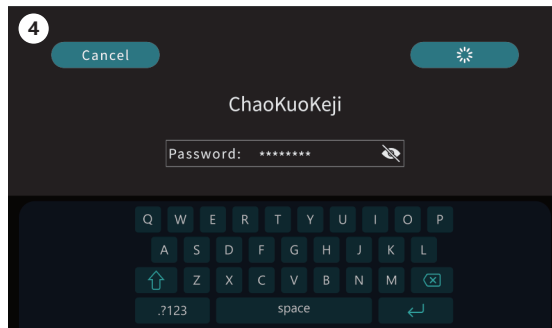

Click "Join" to connect to the network;

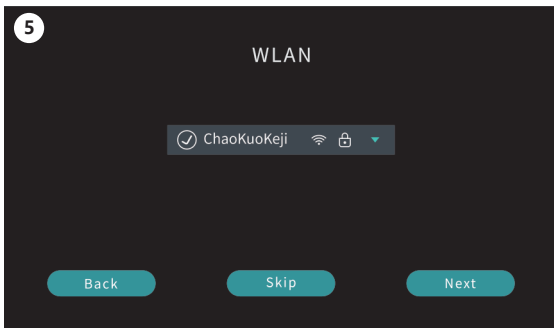

After the printer successfully connects to the network click "Next" to start the printer calibration.

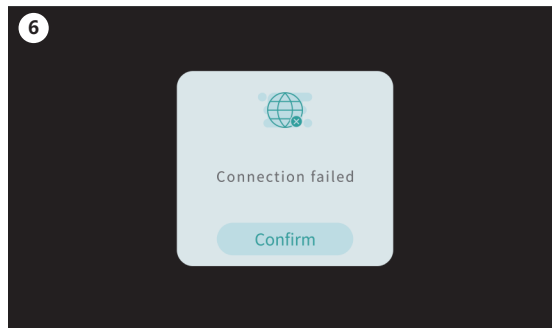

If the connection fails, click "Confirm" to attempt to reconnect to a new connection.



Access to the main display page;

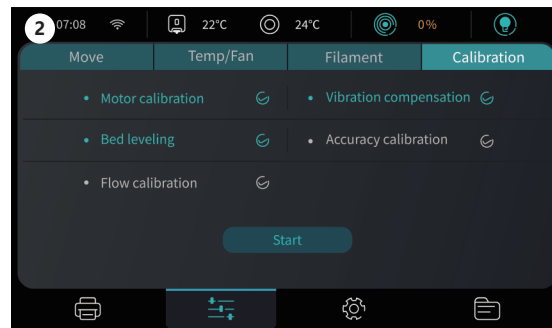

click "⚙️" – "Calibration", option "Motor Calibration", "Vibration compensation" and "Bed leveling". Click "Start";

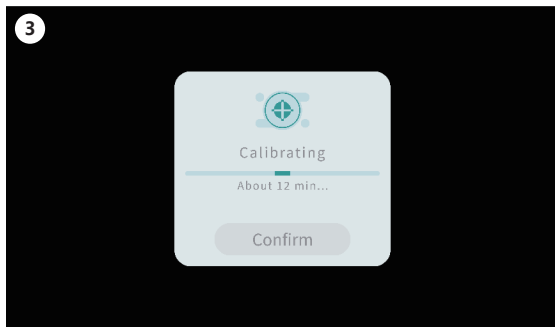

Calibration begins and takes about 12 minutes;

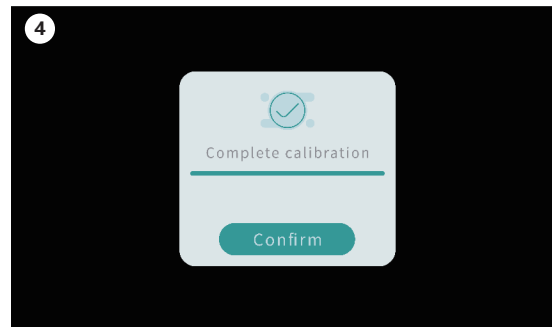

Calibration completed,click "Confirm".

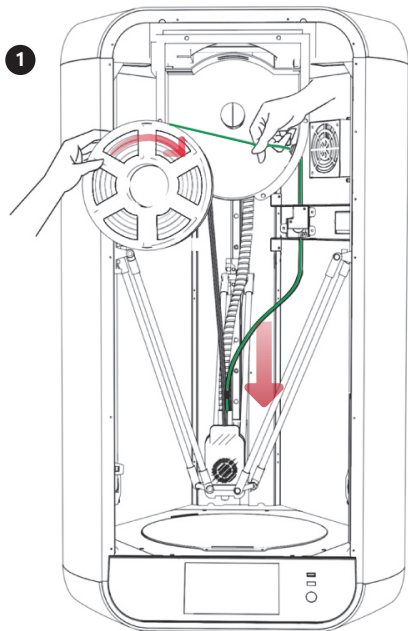

Push one end of the filament into the feed tube on the right side of the filament dryer box, passing through the filament detector and filament clogging detector, and push the filament down into the effector until the filament cannot move forward;

\*The filament spool rotation is clockwise.

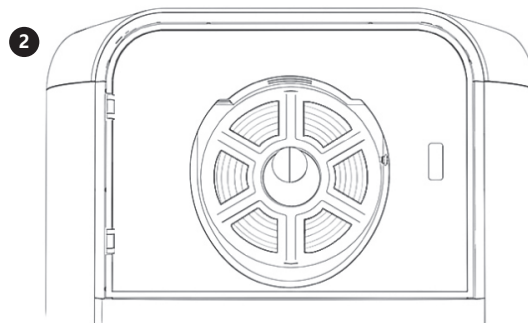

Install the filament into the filament holder;

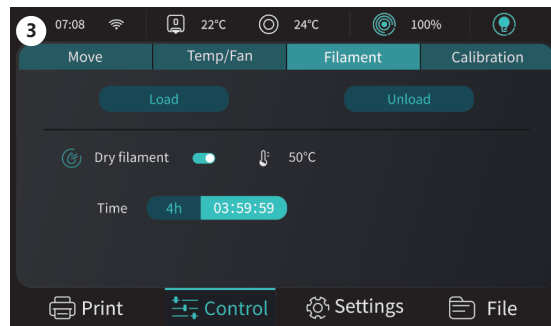

Click on "Control" - "Filament" - "Load";

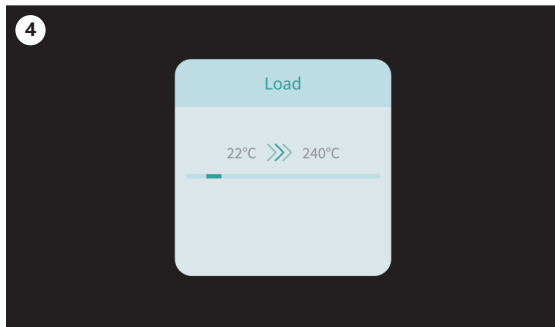

Wait for the temperature to rise to 240°C;

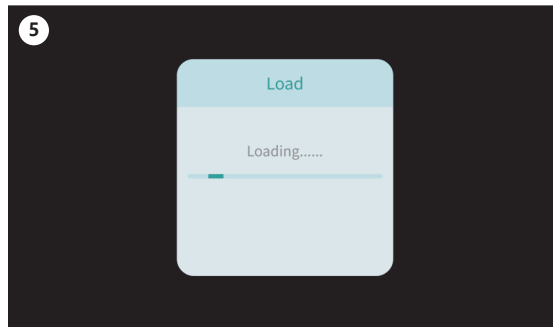

The extruder is loading the filament until the filament is extruded from the nozzle.

1



Apply a layer of glue stick to the PEI sheet;

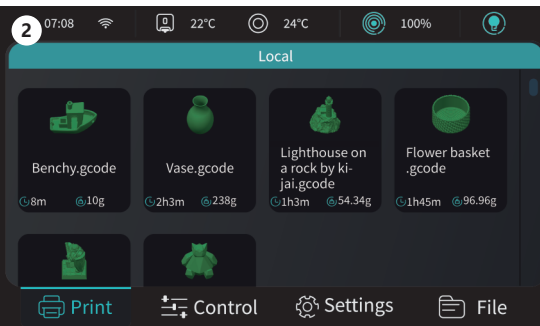

Click on "Print" and select the model you want to print;

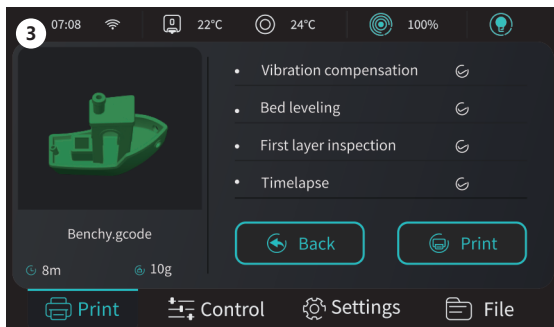

Click "Print" to start printing.

\*Functions can be manually enabled based on your printing requirements.

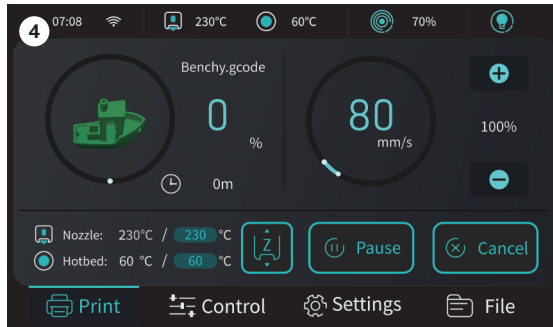

If the nozzle is too low or too high when printing the first layer, you can click "Z" during printing to adjust the height of the nozzle and the adjustment will be automatically saved.

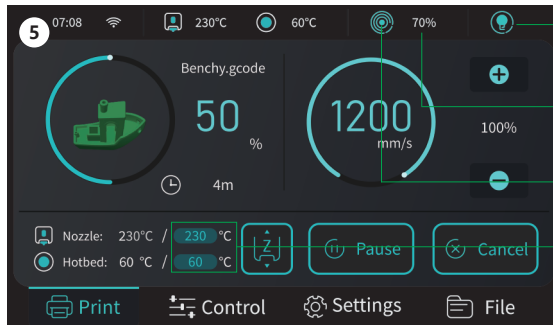
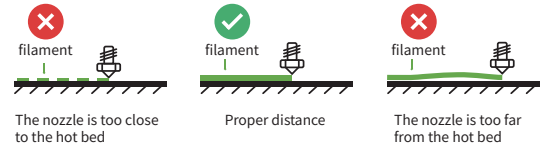

Control the switch of LED lights

Remaining filament weight

Filament drying box status: When it lights up, it means the filament drying box is heating.

The temperature of the nozzle and hot bed can be manually modified during printing.

Please go to flsun official website to download Flsun Slicer :

Official website: <https://flsun3d.com>

Please visit the official Flsun Wiki for more information on machine use, maintenance and FAQs:

<http://wiki.flsun3d.com/en/home>

By scanning the QR code you can choose any channel to get the latest product updates and related news.

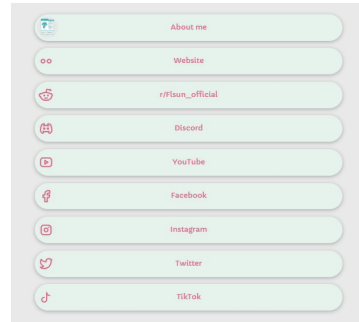

If you need additional assistance, please feel free to contact us:

After-sales e-mail: [service@flsun3d.com](mailto:service@flsun3d.com)

# Go all the way forward and break through the limitations!

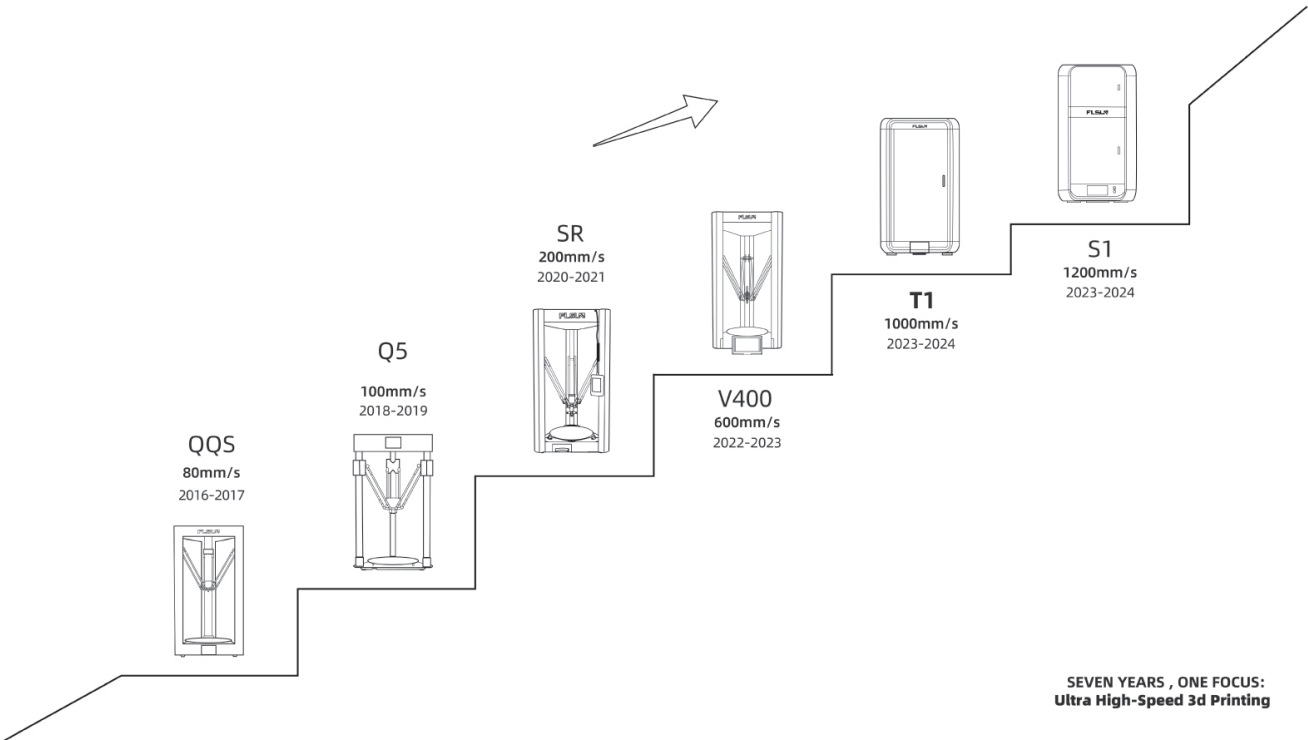

SEVEN YEARS , ONE FOCUS:  
Ultra High-Speed 3d Printing



**FLSUN**

**Bring the personalized production capacity to everyone's desktop**

[www.flsun3d.com](http://www.flsun3d.com)