



Ranein

Portable Tankless Gas Water Heater

Instruction For Installation And Use

Model: RO4K-P



Contact Service

www.raneinrv.com
service@raneinrv.com



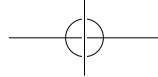

⚠ WARNING

FIRE OR EXPLOSION HAZARD

If you smell gas:

1. Do not attempt to light appliance and make sure appliance is in the OFF position.
2. Extinguish any nearby flame(s).
3. Shut off cylinder fuel supply valve if so equipped, or if equipment with a disposable fuel cylinder, disconnect the cylinder.
4. Leave the area immediately.
5. Allow gas to dissipate for 5 minutes.
6. If gas smell has dissipated from the area, the appliance, and fuel supply, follow steps 1-5 and have appliances serviced.

Failure to follow these instructions could result in fire or explosion, which could cause property damage, personal injury, or death.

Improper installation, use, adjustment, alteration, service, or maintenance can cause injury or property damage. Refer to this manual. For assistance or additional information, consult a qualified installer, service agency, or gas supplier.

Keep this appliance away from all combustible material. Minimum clearances rear at 20 inch, two sides at 40 inch, top at 40 inch. Turn gas off at cylinder valve after use. Disconnect and remove cylinder before storing this appliance indoors.

* Please retain the instruction manual for future reference.

Do not store or use gasoline or other flammable vapors and liquids in the vicinity of this or any other appliance.

⚠ DANGER

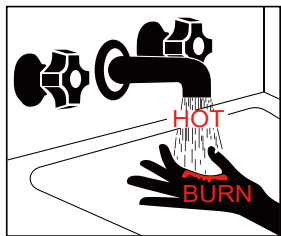

Water temperature over 125°F (52°C) can cause severe burns instantly or death from scalds. Children, disabled and elderly are at highest risk of being scalded. See instruction manual before setting temperature at water heater. Feel water before bathing or showering.

www.raneinrv.com

service@raneinrv.com

You're All Set!

Thanks for purchasing your new Ranein RH13K \ RH18K residential tankless water heater. This convenient, safe and high efficiency product will open the doors to enjoying endless hot water.

We highly suggest you take the time to read through all of the safety and installation procedures in this manual, before attempting to install your new residential water heater.

Always remember we're here for you via our online helpdesk located at

www.raneinrv.com

Read this manual

Inside you will find many helpful hints on how to use and maintain your water heater properly. A little preventive care on your part can save you time and money over the life of your water heater. You'll find many answers to common problems in the Troubleshooting Guide. If you review the chart of Troubleshooting Tips first you may not need to call for service.

Read the safety information

To Ensure your safety and the safety of others, we have included important safety warnings throughout this manual.

All safety messages will follow the safety alert symbol and the words:

"CAUTION", "DANGER" "WARNING" or "NOTICE".

These words mean:

⚠ CAUTION

A potentially hazardous situation that may result in minor or moderate injury.

⚠ DANGER

An imminently hazardous situation that will result in death or serious injury.

⚠ WARNING

A potentially hazardous situation that could result in death or serious injury and/or damage to property.

⚠ NOTICE

Attention is called to observe a specified procedure or maintain a specific condition.

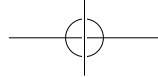

CATALOGS

| | |
|--|-------|
| Warning & You're All Set..... | 1-2 |
| General Safety..... | 3-10 |
| Installing The Water Heater..... | 10-32 |
| Electrical Connection..... | 33-38 |
| Operation..... | 39-40 |
| Maintenance..... | 41-46 |
| Troubleshooting & Error Code..... | 47-48 |
| Warranty & Related Residential Models..... | 49-50 |

Important Safety Information Read All Instructions Before Using

Be sure to read and understand the entire Use and Care Manual before attempting to install or operate this water heater. It may save you time and money. Pay particular attention to the Safety Instructions. Failure to follow these warnings could result in serious bodily injury or death. Should you have problems understanding the instructions in this manual, or have any questions, STOP, and get help from a qualified service technician, or the local gas utility.



⚠ DANGER

Properly install water heater

Failure to properly install the water heater indoors as outlined in the Installation Instructions in this manual can result in unsafe operation of the water heater. To avoid the risk of fire, explosion, or asphyxiation from carbon monoxide, never operate this water heater unless it is installed properly and has an adequate air supply for proper operation. Be sure to inspect the flue terminal for proper installation at initial start-up and at least annually thereafter. Refer to the Care and Cleaning section of this manual for more information regarding flue terminal inspection.

⚠ WARNING

Gasoline, as well as other flammable materials and liquids (adhesives, solvents, paint thinners etc.), and the vapors they produce are extremely dangerous. Do NOT handle, use or store gasoline or other flammable or combustible materials any where near or in the vicinity of a water heater or any other appliance. Be sure to read and follow the labels on the water heater, as well as the warnings printed in this manual Failure to do so can result in property damage, bodily injury or death.

⚠ DANGER

Vapors from flammable liquids will explode and catch fire causing death or severe burns. Water heater has a main burner flame. The main burner flame

1. Can come on at any time and
2. Will ignite flammable vapors

Do not use or store flammable products such as gasoline, solvents or adhesives in the same room or area near the water heater.

Vapors:

1. Cannot be seen
2. Are heavier than air
3. Go a long way on the floor
4. Can be carried from other rooms to the main burner flame by air currents

Keep flammable products:

1. Far away from heater
2. In approved containers
3. Tightly closed
4. Out of children's reach

Installation:

Do not Install water heater where flammable products will be stored or used unless the main burner flame is at least 18" above the floor. This will reduce, but not eliminate, the risk of vapors being ignited by the main burner flame.

Read and follow water heater warnings and Instructions. If owners manual is missing, contact the retailer or manufacturer.

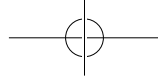

⚠ DANGER

Liquefied petroleum gas models

- Propane gas have an odorant added to aid in detecting a gas leak. Some people may not physically be able to smell or recognize this odorant. If you are unsure or unfamiliar with the smell of propane gas, ask the gas supplier. Other conditions, such as "odorant fade", which causes the odorant to diminish in intensity, can also hide or camouflage a gas leak. Always check with commercial leak detector or soapy water.
- Gas detectors are recommended in propane gas applications and their installation should be in accordance with the detector manufacturer's recommendations and/or local laws, rules, regulations or customs.
- To avoid possible equipment damage, personal injury or fire, do not connect the water heater to a fuel type not in accordance with the portable tankless water heater data plate. These portable tankless water heaters are only for propane gas, not certified for any other fuel type.
- Propane appliances should not be installed in and unventilated place (for example, in a basement) if such installation is prohibited by federal, state and/or local laws, rules, regulations or customs.
- Propane gas must be used with great caution. It is heavier than air and will collect first in lower areas making it hard to detect at nose level.
- Before attempting to light the water heater, make sure to look and smell for gas leaks. Use a soapy solution to check all gas fittings and connections. Bubbling at a connection indicates a leak that must be corrected. When smelling to detect a gas leak, be sure to sniff near the floor also.
- It is recommended that more than one method, such as soapy solution, gas detectors, etc., be used to detect leaks in gas applications.

Notice: If a gas leak is present or suspected:

- **DO NOT attempt to find the cause yourself.**
- **DO NOT try to light the water heater.**
- **DO NOT touch any electrical switch.**

⚠ WARNING

California Proposition 65

This appliance contains chemicals known to the State of California to cause cancer, birth defects, or other reproductive harm.

If the information in these instructions is not followed exactly, a fire or explosion may result causing property damage, personal injury or death.

⚠ WARNING

1. Do not leave unattended.
2. The exhaust gas and top of the portable tankless water heater is HOT! Do not place hands or any foreign object near the top of the heater.
3. This water heater is only intended for use with non-potable water (such as a portable shower). Do not connect to potable water, health risk and/or consequences if it is used for heating water for human consumption.
4. This water heater is for point of use (dishwashing, washing, showering, etc), for temporary water heating and not for connection to a permanent inlet water connection or for a water distribution system to supply multiple outlets. Not suitable for drinking and cooking.
5. Do not use in high wind conditions.
6. If the smell of gas is detected, turn off the gas valve at the cylinder immediately! Do not use flame for leak detection.
7. Use only Propane gas.
8. Use only outdoors.
9. The minimum environmental temperature for safe storage and operation of the water heater must be above 32°F, if not, may cause water heater damage and dangerous.
10. **ONLY USE IN OUTDOORS AREAS. CARBON MOXOXIDE HAZARD-USING THIS APPLIANCE IN AN ENCLOSED SPACE WILL CAUSE DEATH-DO NOT USE IN CARAVANS, TENTS, MARINE CRAFT, CARS, MOBILE HOMES OR SIMILAR LOCATIONS.**

Intended Purpose and Benefits of the Ranein 6L

Ranein 6L tankless water heater is a propane gas fired portable tankless water heater capable of delivering 0.44 to 1.32 gallons of hot water almost anywhere. The portable tankless water heater has standard 5/8"-18UNF NPT pipe fittings and an adapter for using a standard garden hose for inlet water supply.

Gas should be supplied with a max 20lb propane cylinder(not included). A CSA certified regulator and hose is included with the appliance.

A shower head with on/off switch and multiple spray patterns is included. Ignition is automatic and powered by 2 size D batteries (not included). Burner will be ignited when has water flows and will be shut off when the water flows stopped. No pilot light!

Ideal operating use with water pressure between 10-110 PSI/70-760 kPa.

Product Breakdown & Features

- Water controlled automatic ignition: water pressure between 10-110 PSI/70-760 kPa opens the ignition circuit for easy and convenient operation.

- Auto cut-off protection: The auto cut-off protection will shut the gas supply off immediately in the event of flameout to reduce the risk of gas leakage.
 - Removable drain plug to avoid water pipe and regulator damage caused by freezing water*.
 - Anti-dry combustion protection: The portable tankless water heater will shut off the gas supply in the event water stops flowing through the portable tankless water heater.
- * Read the maintenance section on draining the portable tankless ater heater entirely to avoid freeze related issues.

Technical Specifications

| | | | |
|--------------------|--|--------------------|-------------------|
| Fuel Type | Propane Gas | Model | RO4K-P |
| Btu/hr | 41,000 | Colour | Space grey |
| Dimensions | 11.42" x 4.5" x 14.5" | | |
| Max Water Pressure | 110.0PSI/760kPa | Inlet Gas Pressure | 11" w.c.(2.74kPa) |
| Ignition | Electric pulse, size D battery powered (No electrical connection required) | | |
| Protections | Auto-cut off water control, automatic ignition, anti-dry combustion protection, over-pressure overheating and flameout protection. | | |
| Pipe Fittings | 1/2" BSP for gas inlet, water inlet and water outlet | | |

Product Dimensions

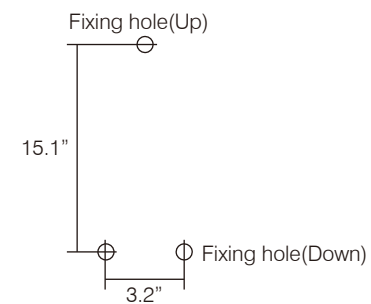
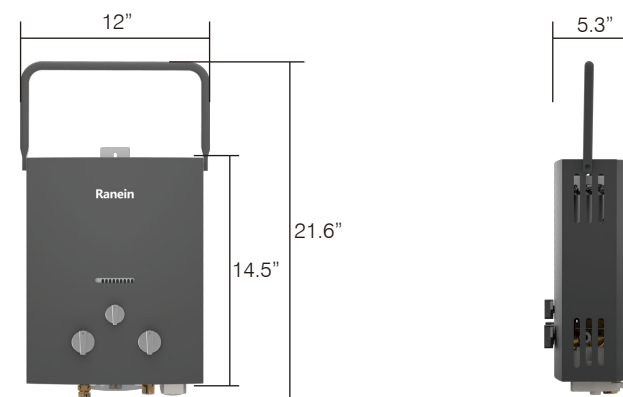
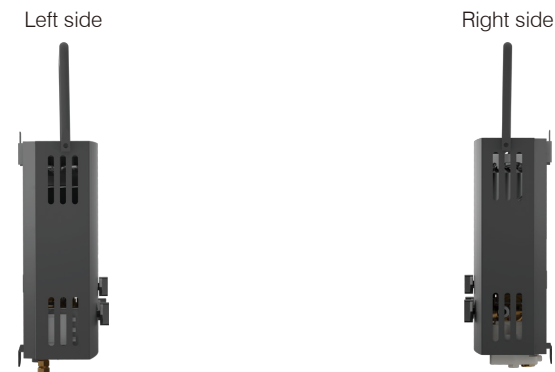

Construction & Components

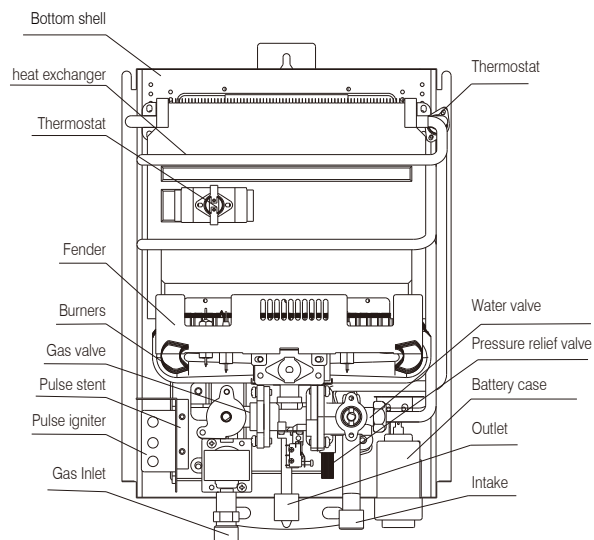

For parts replacement, please find below for obtaining replacement parts.

Parts Replacement

Parts Ordering

⚠ WARNING

For your safety, DO NOT attempt to disassemble, repair, or replace any portion of this unit.

Refer all repairs, service, and/or adjustment to qualified serviceman. Address all parts orders to the distributor or manufacturer where the water heater was purchased. All parts orders should be included:

1. The model and serial number of the water heater from the rating parameter.
2. Parts description (as shown above).

⚠ CAUTION

Label all wires prior to disconnection when servicing controls. Wiring errors can cause improper and dangerous operation. Verify proper operation after servicing. THIS CONNECTION IS FOR LOW-VOLTAGE BATTERY ONLY. DO NOT CONNECT TO 120 OR 240 VOLTS AC.

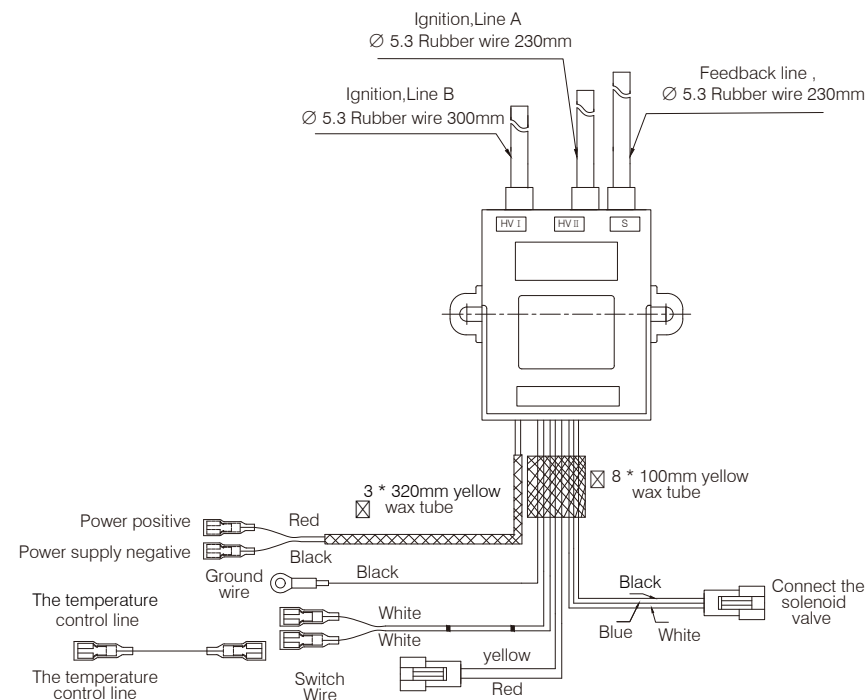

Getting Started

1. Check carton box for damage. Damages caused in shipment must be reported immediately. Please contact us on our support page at www.raneinrv.com.
2. Make sure you have all the parts.
3. If using a standard garden hose, attach the 3/4" GHT garden hose adapter to

⚠ NOTICE

Included parts and accessories may vary depending on country and regulations. (Please refer the alphabetical letter below to page 13 to ensure all items are included.)

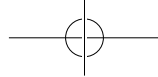

- Ranein 6L outdoor portable tankless gas water heater
- ON/OFF switch shower head with 5 feet red hose and snap on connector
- CSA certified gas regulator with 5 feet hose
- Gas compression fitting *fixed to gas inlet already*
- 1/2"BSP female x 3/4" GHT male, 1/2" BSP female x 3/4" GHT female garden hose adapter
- Hardware pack

the fitting marked "Water Inlet". Check to make sure the filter inside the water inlet is in place and clean. Then attach your water inlet/garden hose.

- In order to prevent gas leakage, we have the gas regulator pre-installed from the factory, you can connect gas supply line to the portable tankless water heater directly. Always remove and reinstall it the gas regulator by wrench if necessary. DO NOT OVER TIGHTEN. OVER TIGHTING MAY CRACK THE GAS REGULATOR CAUSING A GAS LEAK. Check gas leakage before operation.
- Attach shower hose to the fitting marked "Water Outlet". Do not over tighten.
- Install 2 size D batteries in the compartment on the bottom left of the heater. Check that batteries are facing the correct direction.
- Use the top tab on the portable tankless water heater to suspend from a mounted screw. Place at a comfortable height without putting stress on the gas hose.
- Connect gas regulator and gas inlet brass fitting by wrenches with torque force between 20-28N/m.
- In accordance with the specifications for LP gas cylinder of the U.S.Department of Transportation (DOT) or the Standard for Cylinders, Spheres, and Tubes for the Transportation of Dangerous Goods and Commission, CAN/CSA B339, as applicable.
- Place dust cap on cylinder valve outlet whenever the cylinder is not in use. Only

LP gas supply cylinders to be used must be:

- Constructed and marked in accordance with the specifications for LP gas cylinders of the Tubes for Transportation of Dangerous Goods and Commission, CAN/CSA-B339, as applicable.
- Provided with a listed overfilling prevention device.
- Provided with a cylinder connection device compatible with the connection.

install the type of dust cap on the cylinder valve outlet that is provided with the cylinder valve. Other types of caps or plugs may result in leakage of propane.

- With low discharge frequency, the exhaust gas will mixed with the air in the combustion chamber when the battery voltage from the unit is low. The water heater will make a big combustion sound and yellow flame once the mixed gas in the combustion chamber was ignited.

NEVER using a returned or defective unit, please contact Ranein for a brand new replacement. We provide 48 hours turn around for defective unit at no cost and 1 year warranty for all Ranein products. Any questions, repairs, parts replacement please contact us with your order information and address information at service@raneinrv.com.







LEAVE GAS CYLINDER VALVE IN THE "OFF" POSITION

⚠ WARNING

GAS HOSE ADAPTER

THE Ranein 6L PORTABLE TANKLESS WATER HEATERS HAVE 5/8"-18UNF ADAPTER ALREADY ATTACHED TO THE GAS INLET ON THE WATER HEATER. ALWAYS CHECK FOR GAS LEAKS BEFORE USING HEATER.

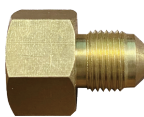
In The Box

| Item | Description | Identification | Quantity |
|------|--|---|----------|
| A | Ranein 6L outdoor portable tankless gas water heater |  | 1 piece |
| B | Shower head |  | 1 set |
| C | Gas regulator with 5 feet hose |  | 1 set |
| D | Dust shield |  | 1 set |
| E | 1/2" BSP female x 5/8" GHT male |  | 1 pieces |
| F | Hardware pack |  | 1 set |

Installation Instructions

How to use the garden hose

1. Flared Gas Fitting

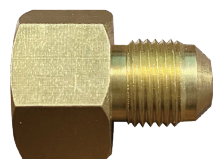

1/2" BSP female x 5/8" GHT male

⚠ NOTICE

MAKE SURE PUT THE RUBBER GASKET IN ALL FITTINGS BEFORE CONNECTION.

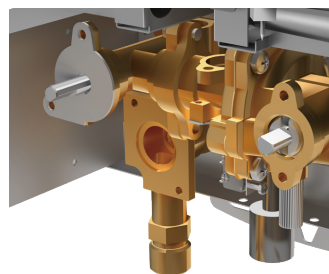

2. Preparation

ONLY USE IN OUTDOOR AREAS. CARBON MOXOXIDE HAZARD-USING THIS APPLIANCE IN AN ENCLOSED SPACE WILL CAUSE DEATH-DO NOT USE IN CARAVANS, TENTS, MARINE CRAFT, CARS, MOBILE HOMES OR SIMILAR LOCATIONS.

- Use appliance only with LP (propane) gas and the regulator valve assembly supplied.
- Installation must conform with local codes or in the absence with National Fuel Gas Code, ANSI Z223.1/NFPA 54, or the Propane Installation Code, CSA B149.1, or the Propane Storage and Handling Code, CSA B149.2.
- Reinforcement of the wall is required where the wall should be strong enough to hold the water heater. The mounting location for the water heater should allow for easy access and operation.

- Take the appliance out from carton box and remove the foam and plastic bag, position the upper mounting bracket and partially install the center mounting screw. Hang the upper bracket on the screw or hang up by handle for temporary fixed.

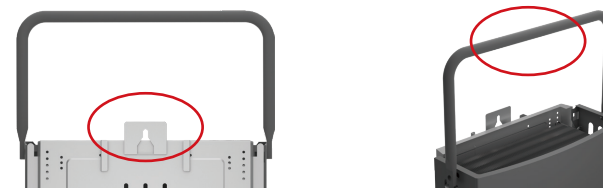

- Install 2 size D batteries (NOT included) in the battery box on the bottom of the appliance. Check the batteries are facing the correct direction.

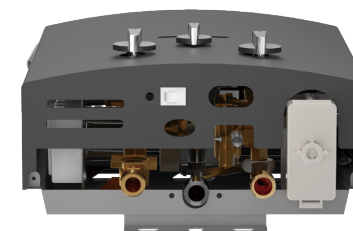

- Use shifting wrenches to attach supplied gas regulator (with brass connector already attached) to the appliance. And connect to the bottom of the appliance marked "Gas inlet". **Do not over tighten. Over tighten may causing a gas leak!** Ensure that you use supplied washers on all connectors and check for any gas smell. Please connect with torque force between 20-28N/m.

Before ignition as instruction. Make sure the gas inlet connector and water inlet connector are screwed all the way on.

Tighten the fittings with use wrenches on both the brass adapter fitting on the appliance and the brass connector on the end of the hose.



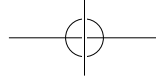

- Attach the water output device (shower head) to the fitting marked "Water outlet". DO NOT OVER TIGHTEN! Make sure to insert the supplied rubber gasket at the connections. Tighten by hand only.
- Only use the gas regulator & hose supplied with this appliance.
- A new pressure relief valve, complying with the standard for relief valves and automatic gas shut-off devices for hot water supply system, ANSI Z21.22/CSA 4.4, must be installed at the hot water outlet connection of the water heater during installation. Local codes shall govern the installation of any relief valve. Relief valve is NOT attached with gas water heater.

Water supply installation

1. Install a COLD water shut-off valve near the inlet line on the water heater. This valve will be used for servicing and draining purpose.
2. Before attaching the water line to the water heater, open the shut-off valve. Run the water until it has purged all contaminants (sand, debris, air, caulking, etc).
3. Install a service valve on the end of the COLD water supply line and connect it to the water inlet on the water heater.
4. Open the shut-off valve in the COLD water inlet line to check the water flow through the water heater.
5. Close the shut-off valve and remove, clean and replace the water filter.

⚠ WARNING

Should overheating occur or the gas supply fails to shut off, turn off the manual gas control valve to the appliance.

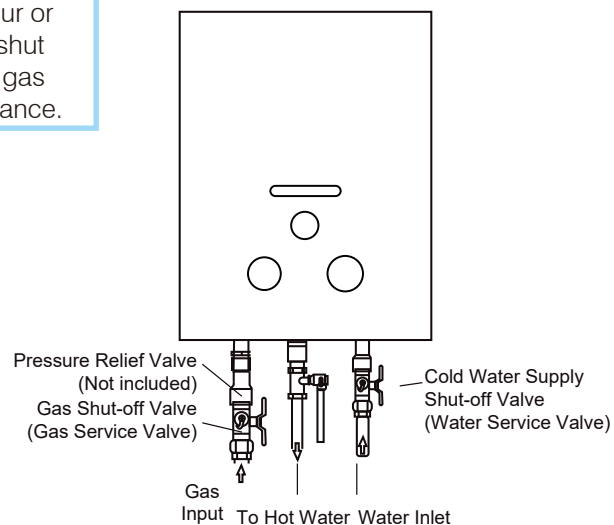

- Place at a comfortable height without putting stress on the gas hose. If the unit is to be permanently mounted, use screws to attach the bottom tab firmly.
- Before opening LP cylinder valve, check the coupling nut for tightness. When appliance is not in use, turn off LP cylinder valve on supply cylinder.
- Never use LP cylinder if visibly rusted, damaged or out of date.
- Clean and inspect the hose before each use of the appliance. If there is evidence of abrasion, wear, cuts or leaks, the hose must be replaced prior to the appliance being put into operation.

⚠ WARNING

THE PORTABLE TANKLESS WATER HEATER IS CAPABLE OF PRODUCING SCALDING WATER TEMPERATURES!

Connecting, Disconnecting From Gas Cylinder And Storage

This appliance shall only be connected to a 20lb (Size 1: $\square 12\ 5/16'' \times H17\ 5/16''$; Size 2: $\square 11\ 13/16'' \times H17\ 7/16''$) cylinder with a POL cylinder valve certified to CAN/CSA-B339. The LP-gas cylinder(s) must be constructed and marked in accordance with the specifications for Cylinders, Spheres, and Tubes for the Transportation of Dangers Goods, CSA B339.

Please always use cylinder at upright position for vapor withdrawal. Connect certified gas regulator QCC-1 with LP gas supply cylinder by hand, regulator hose connect with appliance in gas inlet fitting by wrench.



Connecting to cylinder:
Connect the gas regulator to the gas cylinder, tightening using two fingers support posts.



Disconnecting from cylinder:
Disconnect the gas regulator from the gas cylinder, tightening using two fingers support posts.

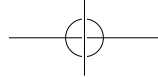

Please inspect the hose before each use of the appliance. If it is evident there is excessive abrasion or wear, or the hose is cut, it must be replaced prior to the appliance being put into operation. The replacement hose assembly shall be that specified by the manufacturer.

⚠ WARNING

Never use an open flame to test for gas leaks, because death, personal injury and/or property damage can result. The water heater and its gas connections **MUST** be leak tested at normal operating pressures before the unit is placed in operation.

Turn on the gas shut-off valve to the water heater. Use a soapy water solution to test for leaks at all the connections and fittings. If bubbles are seen, it indicates a gas leak that must be corrected and contact a qualified service technician.

The gas must be turned off at the LP gas supply cylinder when the water heater is not in use.

When the LP-gas supply cylinder is not disconnected from the water heater, the water heater and cylinder must be stored outdoors, in a well ventilated space, out of the reach of children, and must not be stored in a building, garage or any other enclosed area.

Storage of the water heater indoors is permissible only if the cylinder is disconnected and removed from the water heater.

Cylinders must be stored outdoors, in a well ventilated space, out of the reach of children, and must not be stored in a building, garage or any other enclosed area.

⚠ NOTICE

Should overheating occur or the gas supply fail to shut off, turn off the manual gas control valve to the water heater.

- Do not store a spare LP gas cylinder under or near this appliance.
- Never fill the cylinder beyond 80 percent full. And,
- If the information of A and B above is not followed exactly, a fire causing death.

Before Going To The Use Section

Check around area for flammables, especially gasoline or other vapors which may ignite. The exhaust and top of the portable tankless water heater will get **HOT!** Make sure there are no foreign objects around the portable tankless water heater or have fallen into the top.

Use And Starting

⚠ WARNING

This model is intended for recreational & portable use only. This model **CANNOT** be permanently mounted or plumbed in any way.

The water heater must not be exposed to flammable vapors or liquids during lighting.

1. Turn on incoming water supply. Ensure that you have abundant water pressure of between 10-110 PSI/70-760 kPa for ideal operation.
2. Turn your water output device to its "off" position.
3. Turn the gas valve on the cylinder all the way open.
4. **IF THE SMELL OF GAS IS DETECTED, TURN OFF THE GAS VALVE IMMEDIATELY!**
5. Set the water control knob on BLUE mark to Maximum.
6. Set the gas control knob on RED mark to Minimum.

Gas flow adjustment knob ("Min" position is lowest temperature)

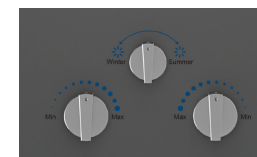

Water flow adjustment knob ("MAX" position is maximum flow)

7. Turn on your water output device to the "on" position and adjust to the desired water flow.
8. There will be a series of audible clicks and the burner will ignite. Please take note the water heater must not be exposed to flammable vapors or liquids during lighting. Should the burner not ignite after 5 seconds, shut off and go to the "Troubleshooting" section.
9. Upon completion of use or storage, open the drain valve (ribbed cylindrical stem next to the water input valve) to ensure draining of water.
10. Turn off your gas supply.

⚠ WARNING

If the outside temperature is around or below freezing (32 °F/0°F), ensure that the drain plug is opened and water drained from the portable tankless water heater after each use to avoid internal damage to the heat exchanger. You will also need to unhook the outgoing water line to ensure that any water in the heat exchanger is drained. Failure to properly drain your portable tankless water heater will cause water damage which may or may not be reparable.

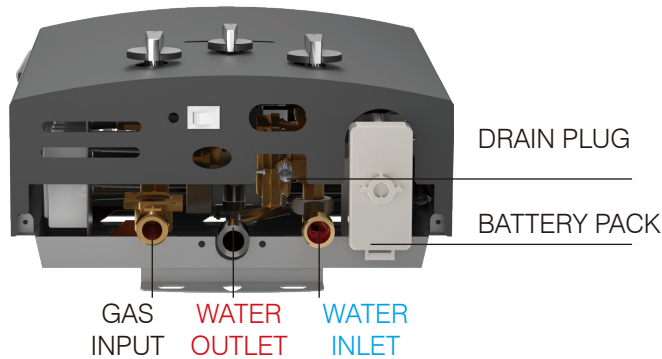

Before Operate The Drain Plug, Must be

1. Ensure that the water heater is disconnected from the gas supply.
2. Ensure that the water heater is disconnected from the water supply (turn off cold water inlet switch).
3. Turn the shower switch to "ON".
4. Ensure that the shower hose is disconnected from the water heater.

Adjustment

The temperature of the outgoing water is dependent on the temperature of the incoming water balanced with the amount of heat applied. Use extreme caution in setting the outlet water temperature.

1. With the water knob set to Max, and the gas knob set to Min, feel the outgoing water. This is the lowest setting available.
2. To initially raise the outgoing temperature, slowly turn the gas valve towards maximum. Adjust slowly and check the temperature often. There will be a slight delay between increasing the gas supply and the increase in water temperature.

Common Issues With Solutions

| Issue | Indication | Solution |
|-------------------------|--|--|
| Water pressure too high | If water pressure is over 110 PSI/760 kPa, the water-out valve will release water and lower the pressure | Increase the valve pressure limit according to local water supply pressure |
| Water pressure too low | If water pressure is below 3.6 PSI/25 kPa, the water heater cannot be ignited | Use the water heater later when pressure becomes higher |
| Low battery | The power of battery will become less after use for some time, thus the water heater cannot be ignited | Change Batteries |
| Over heat protection | Water heater automatically shuts off when water temperature is 176°F (80°C) | Re-start water heater later when water becomes cooler |

Please Protect Your Water Heater From Freeze Damage!

During the stage of no using, the temperature is same between the inside and outside of water, the water will expand when temperature reach 32°F(0°C) even broken the water pipe. This is normal phenomenon and not is the quality problem. Open the drain plug to drain off the residual water in the water heater and then screw it tightly if the environment where the water heater is installed drops below 32°F(0°C). This can prevent the cold from damaging the water heater.

⚠ WARNING

To drain the residual water totally, please keep the water heater in vertical statue when draining water.

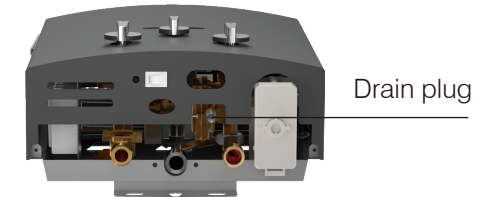

Care And Maintenance

Properly maintained your water heater will provide years of dependable trouble-free service. It is recommended that a periodic inspection of the burner, water filter and top exhaust should be made by service personnel qualified in gas appliance. Repairing might have come loose or is no longer connected.

It is suggested that a routine preventive maintenance program be established and followed by the user.

* It is recommended to do maintenance once a year.

Inspect the area around the water heater to ensure a safe operating environment. Keep water heater area clear and free from combustible materials, gasoline, and

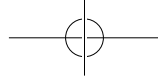

other flammable vapors and liquids. Do not obstructing the flow of combustion and ventilation air. Ensure the unit has not been damaged. If damage or denting is present, contact a service personnel to verify proper operation.

Check for any abnormal sounds during normal operation of the water heater.

Check the burner flames through visible flame window to make sure the combustion is normal during operation of the water heater.

1. Burner with pure blue flame, means well ventilation and combustion adequacy.
2. Burner with yellow/red flame, means combustion insufficiency, air intake is not enough, or appliance bottom block.
3. Burner with a lift-flame, over gas pressure, high wind condition.
4. Max gas but small flame, gas pressure is not enough.

All piping should be checked for gas and/or water leaks. Refer to page 5 of this manual for instructions on leak testing.

The air intake and cold water supply filters should be cleaned monthly. For clean panel surface, dust off and use kitchen cleaner to clean when you feel it is dirty.

DO NOT operate the water heater if you feel something is wrong with the unit.

DO NOT allow children to operate or otherwise handle the unit.

DANGER

Before disconnecting the water supply, make certain no one will be exposed to the danger of the hot water released by disconnecting.

The water may be hot enough to create a scald hazard. The water should be released into a suitable drain to prevent injury or property damage.

DANGER

Hotter water increases the potential for hot water scalds.

DANGER

Failure to perform the recommended routine preventative maintenance can harm the proper operation of this water heater, which can cause carbon monoxide dangers, excessive hot water temperatures and other potentially hazardous conditions.

If You Need Service

All questions, adjustments, repairs, or spare parts need replacement, please contact us on our support service at service@raneinrv.com.

Troubleshooting

Portable tankless water heater will not start-there are no audible clicks at startup:

1. a. The first thing to check is to ensure that the incoming water on the "right" side of the portable tankless water heater. If the incoming and outgoing are reversed, the portable tankless water heater will not work. The incoming is on the far right and the outgoing is in the middle.
2. Check to make sure you have fresh batteries and they are installed in the correct position.
3. The top reason that the portable tankless water heater does not ignite is that there is not enough water pressure. You need a minimum of 3.6 PSI/25 kPa, sustained. Municipal water should supply enough water pressure.

Adjustment:

1. It is possible that some debris or epoxy might have entered the water inlet pipe. Check to see if the filter screen on the water inlet is clear of debris. You can also reverse the hookup by taking your water source and hooking it up to the water outlet side and back flushing the system.
2. Propane gas cylinders sometimes are contaminated with air, especially new cylinders upon their first filling. Cycle the portable tankless water heater turning off and on your output flow or similar. Should a portable tankless water heater fail to light or stay lit after 10 cycles, please contact us via email at service@raneinrv.com.

Portable tankless water heater starts, then shuts off:

1. The portable tankless water heater requires a minimum if about 0.44 gallons per minute (1.5 liters) and a minimum of about 3.6 PSI/25 kPa. **Note: Water pressure is at the lower end of operating parameters. You will need a sustained water pressure of approximately 35-65 PSI/240-450 kPa for adequate use if you are using a 12/18/120 volt pump.**
2. Out of, or low on gas. Propane gas sometimes are contaminated with air, especially new tanks upon their first filling. Cycle the portable tankless water heater on and off by using the shower head switch several times to purge the air from the gas. If this doesn't clear the air then the tank must be purged.
3. One of the ignition sensors is bent and/or too close to the burner. Look to ensure that the ignition pins and the heat sensor are completely vertical and they do a 90 degree to the back of the box. If they are not straight (i.e. a 45 degree angle)

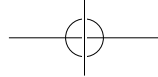

then you can straighten them with pliers.

4. The thermocouple is either too high or too low to complete the circuit. Check to ensure that the thermocouple is flush with the hold in the heat exchanger.
5. The gas sensor wire (looks like a black ground wire on the gas regulator) flange might have come loose or is no longer connected.
6. There is a faulty heat sensor. This is usually diagnosed by taking the front case off of the portable tankless water heater and let it run. If it continues to operate, then one of the sensors and/or the wire harness needs to be replaced. This may also be caused by insufficient clearance on the back of the portable tankless water heater where the majority of air intake is.
7. The valve on the propane tank should be all the way "Open".
8. Fresh batteries are required for ignition spark. Make sure batteries are aligned in the proper polarity (+/-).

The water does not get hot enough:

1. You are operating the portable tankless water heater above 2,000 feet/ 600 meters. We only recommend using it below elevations of 2,000 feet.
2. Look into the viewer panes (middle horizontal windows on the front cover) to see if there is a blue flame. If the flame is yellow there could be a cracked gas regulator. Do Not Attempt to use the portable tankless water heater.

Water is flowing, but there is no hot water coming out:

1. Ensure that you have the incoming water supply and the outgoing water supply hooked up properly. Your water supply should be attached to your incoming connection (located on the far right) and the shower head should be attached to the outgoing water (located as the middle connection).
2. Ensure that you have adequate water pressure of at least 3.6 PSI/25 kPa, sustained.
3. Ensure that you have adequate gas in your propane bottle and that the LP regulator is threaded all of the way on to the portable tankless water heater.
4. Fresh batteries are required for ignition spark. Make sure batteries are aligned in the proper polarity (+/-).

The portable tankless water heater does nothing:

1. Ensure that you have your water source hooked up to the water inlet side(far right connection) and the shower handle is hooked up on the water outlet side (middle connection).
2. Ensure that you have an adequate supply of propane.
3. Ensure that you have fresh batteries.

**Ranein, Enjoy Outdoor Life!
Limited Warranty Information**

Ranein hereby warrants this product to be free of material defects in materials and workmanship when installed and operated according to Ranein's installation and operating instructions. This Limited Warranty extends to the original purchaser and subsequent owners, but only while the product remains as the site of the original installation. This Limited Warranty terminates if moved or reinstalled at a new location. There are no warranties, express or implied made or given other than contained in this Limited Warranty. No agent, employee or representative of Ranein has any authority to bind Ranein to any representation or warranty concerning the Product not contained in this Limited Warranty.

Except as expressly set forth herein, THERE ARE NO REPRESENTATIONS OR WARRANTIES, EXPRESS OR IMPLIED, INCLUDING, WITHOUT LIMITATION, AS TO MERCHANTABILITY OR FITNESS FOR A PARTICULAR PURPOSE WITH RESPECT TO ANY GOODS SOLD HEREUNDER. BUYER'S EXCLUSIVE REMEDY IS LIMITED TO REPAIR OR REPLACEMENT OF THE GOODS SOLD, AT RANEIN'S DISCRETION. RANEIN'S SHALL NOT BE LIABLE FOR INCIDENTAL OR CONSEQUENTIAL DAMAGES.

| | |
|--|--------------------|
| Item | Period of Coverage |
| Heat Exchanger | 1 year |
| All other parts | 1 year |
| Free Accessories (Showerhead, hose, regulator etc) | 30 days |

Coverages are void if the unit is used in a hot water circulation loop, in series with a circulation system or where an on-demand recirculation system is not incorporated.

Owner is responsible for all other costs incidental to repair such as labor, shipping, delivery and permits. Proof of purchase required. Products repaired will be covered under this Limited Warranty for the remainder of term of the original purchase.

This Limited Warranty becomes null and void if any of the following are determined to be a contributing factor to the failure of the product:

1. Abuse, misuse, alteration, neglect or misapplication;
2. Improper or inadequate maintenance;
3. Inadequate water quality;
4. Installation in a corrosive or otherwise destructive environment;
5. Freeze Damage;
6. Scale buildup;

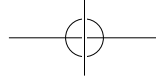

- 
7. Incorrect gas or water pressure;
 8. Acts of force Majeure

This Product is not to be used as a pool or spa heater.

Within the first 30 days of purchase, Ranein will cover all ground shipping costs for warranty related issues, excluding AK, HI, Canada, and any location outside of the continental US. After the first 30 days of purchase, Ranein will cover all shipping costs to the customer for warranty related issues, excluding AK, HI, Canada, and any location outside of the continental US. After the first 30 days of purchase, the customer is responsible for all shipping to Ranein, regardless of reason or circumstance. The method for warranty related shipping will be Ground equivalent with the provider of Ranein's choosing.

AK, HI, Canada, and any location outside of the continental US, will be responsible for all shipping costs, regardless of reason or circumstance.

All shipments of any type of product coming to Ranein for any reason must have an RGA for any repairs to be made. Please contact Ranein to obtain an RGA number prior to shipping anything to Ranein. Failure to do so could result in loss of product. Ranein will not be responsible for replacement due to loss or damage if these steps are not properly followed.