

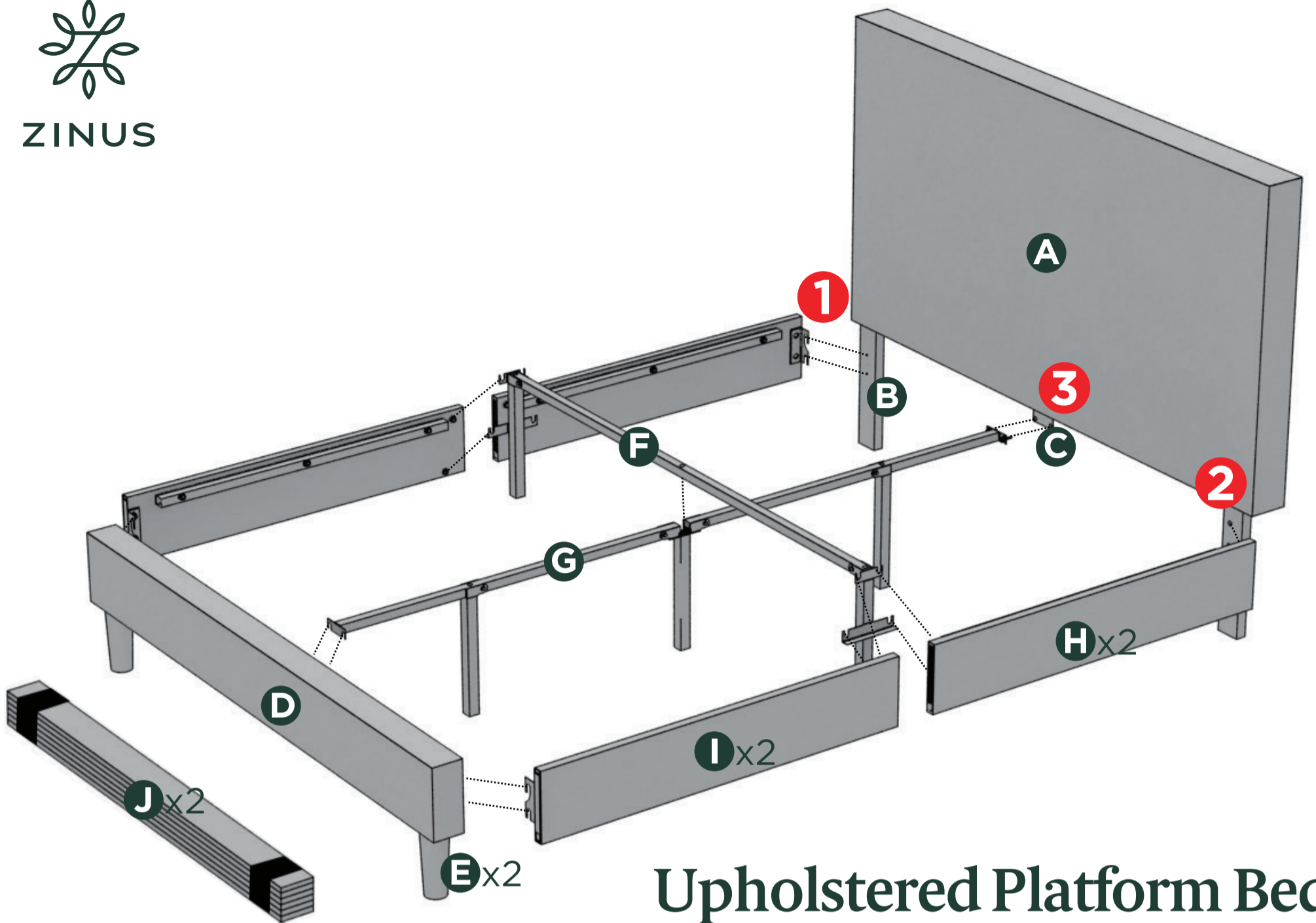

ZINUS



# Upholstered Platform Bed

## Components

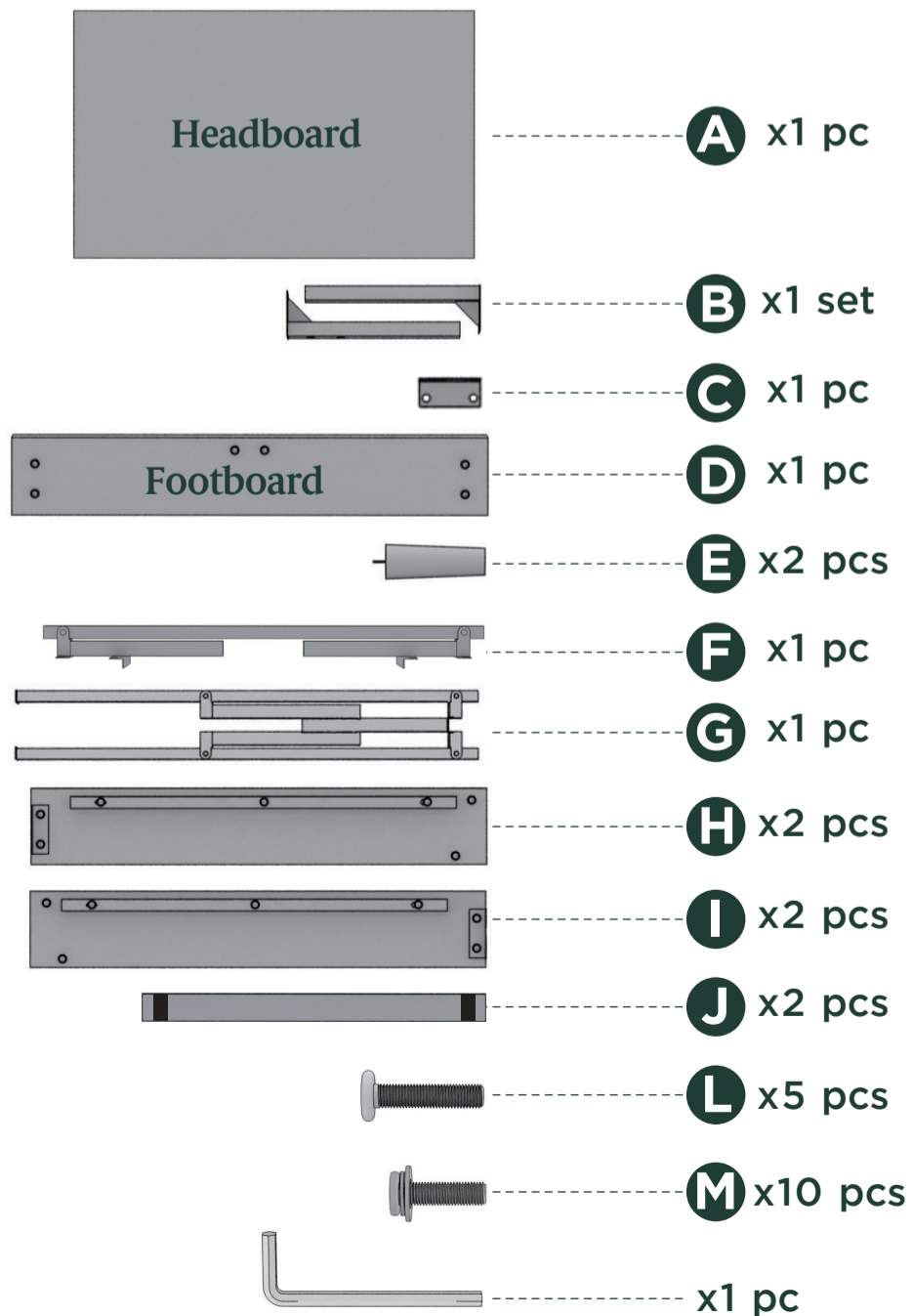

## Return Policy

ZINUS believes you will absolutely love your Upholstered Platform Bed, but if for some reason you want to return the product, please contact us directly before you decide to return your product to the retailer. Our Customer Service organization can answer most concerns and can assist you with any questions you may have about your new product. Please contact us first by emailing [customerservice@zinusinc.com](mailto:customerservice@zinusinc.com) or by submitting a request at <https://support.zinus.com>

The item must be returned in good condition, in original box, with all original proof of purchase, parts and accessories, within the time frame specified by the retailer it was purchased from.

**Please visit [Zinus.com](https://www.zinus.com) for warranty information on your new product.**

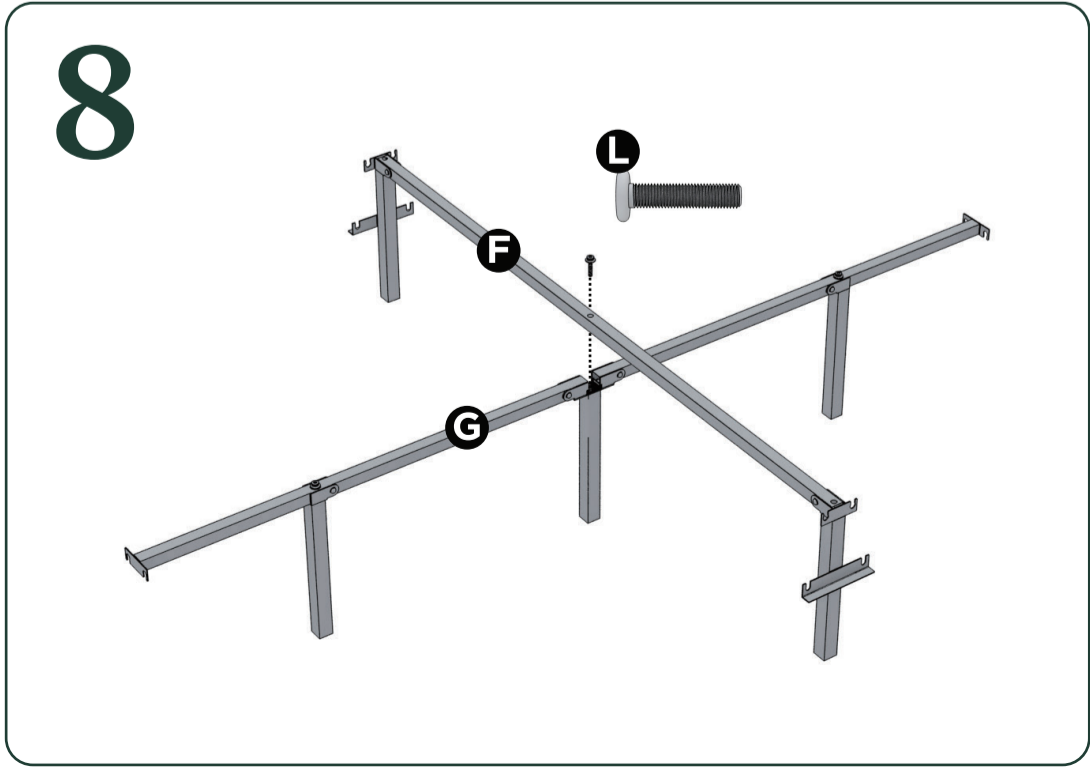
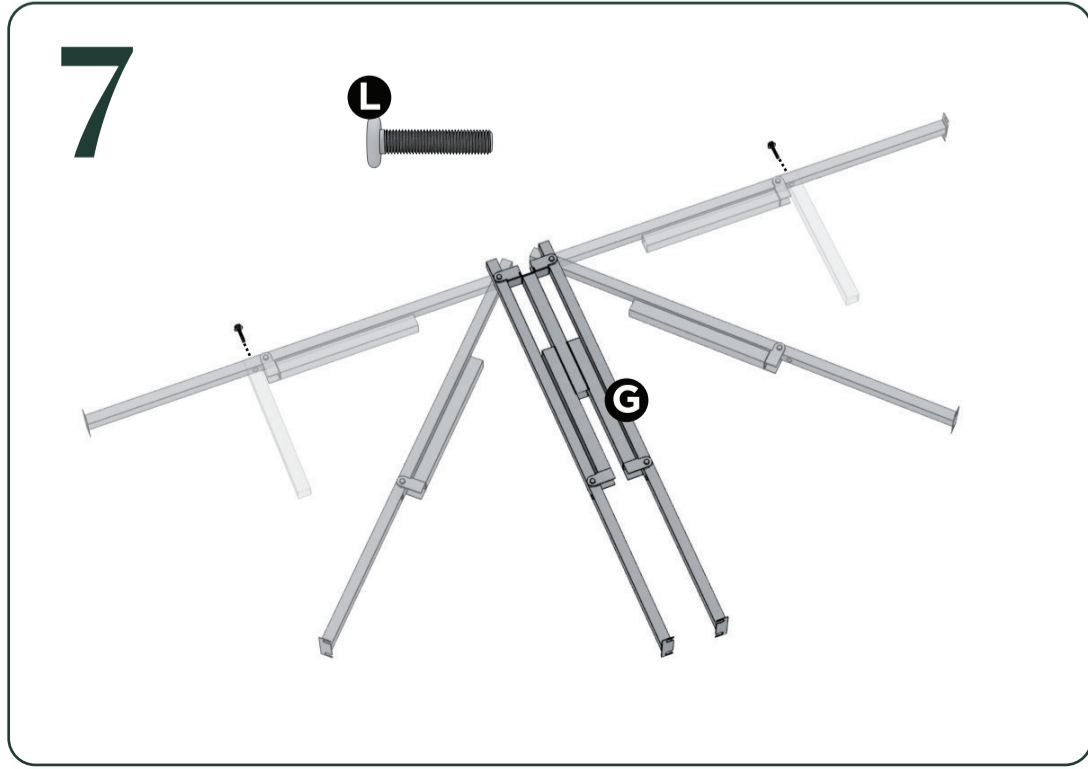
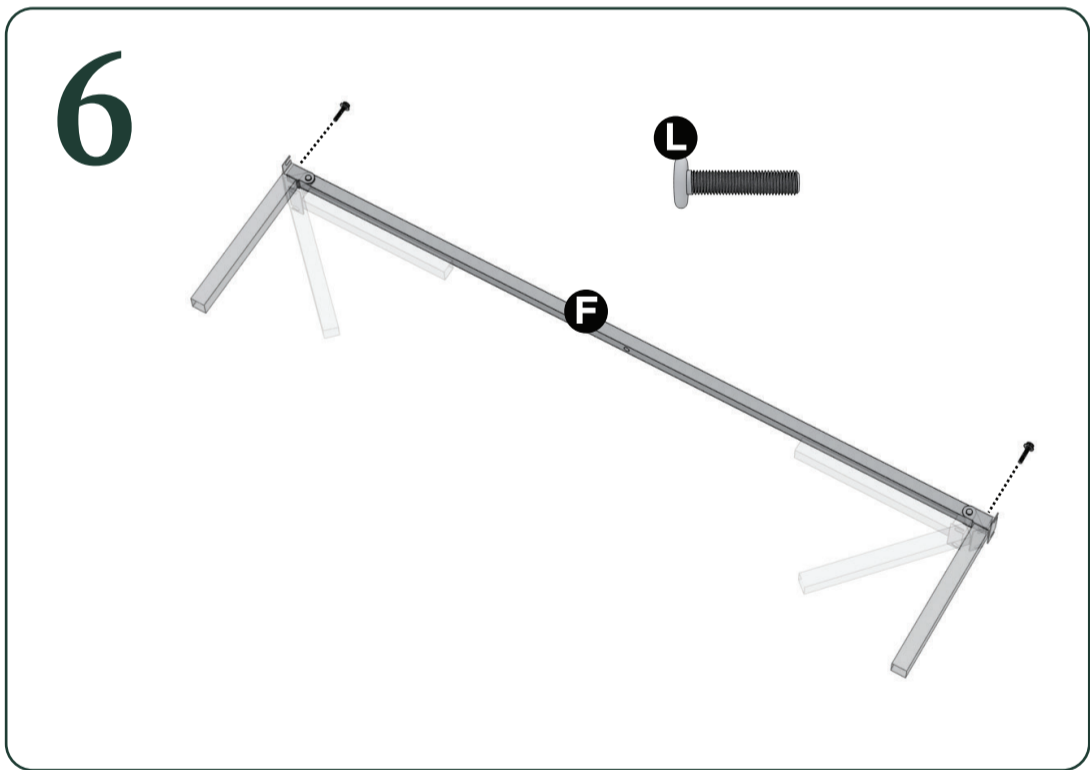
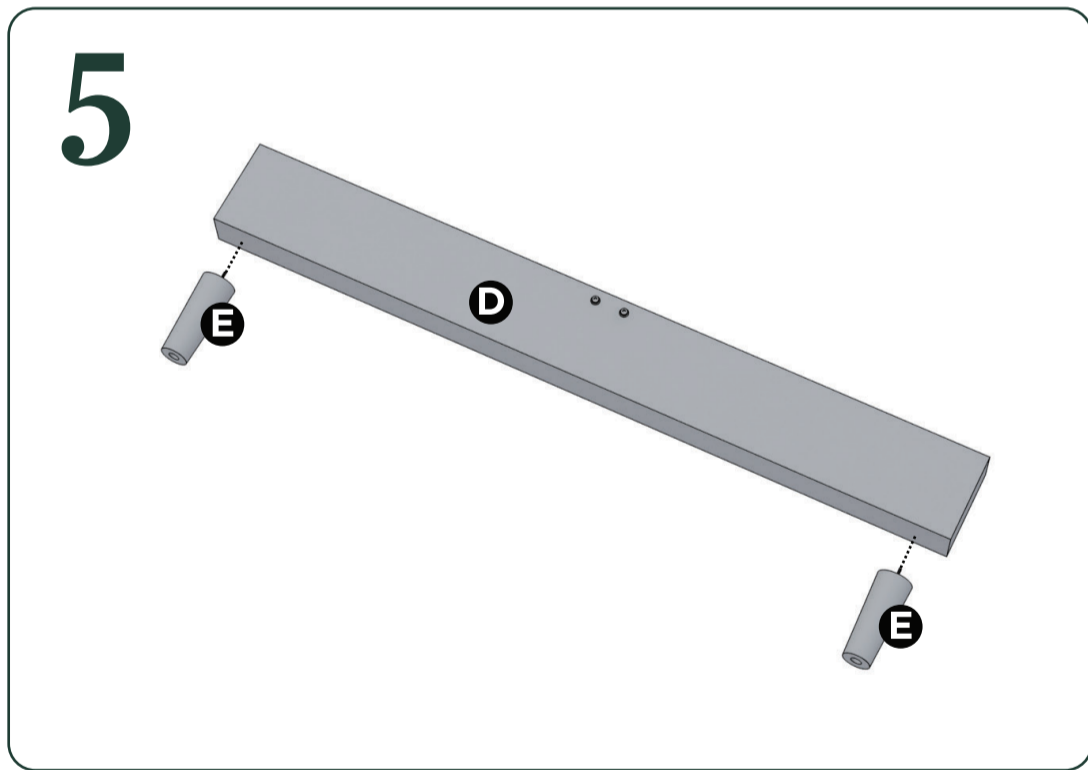
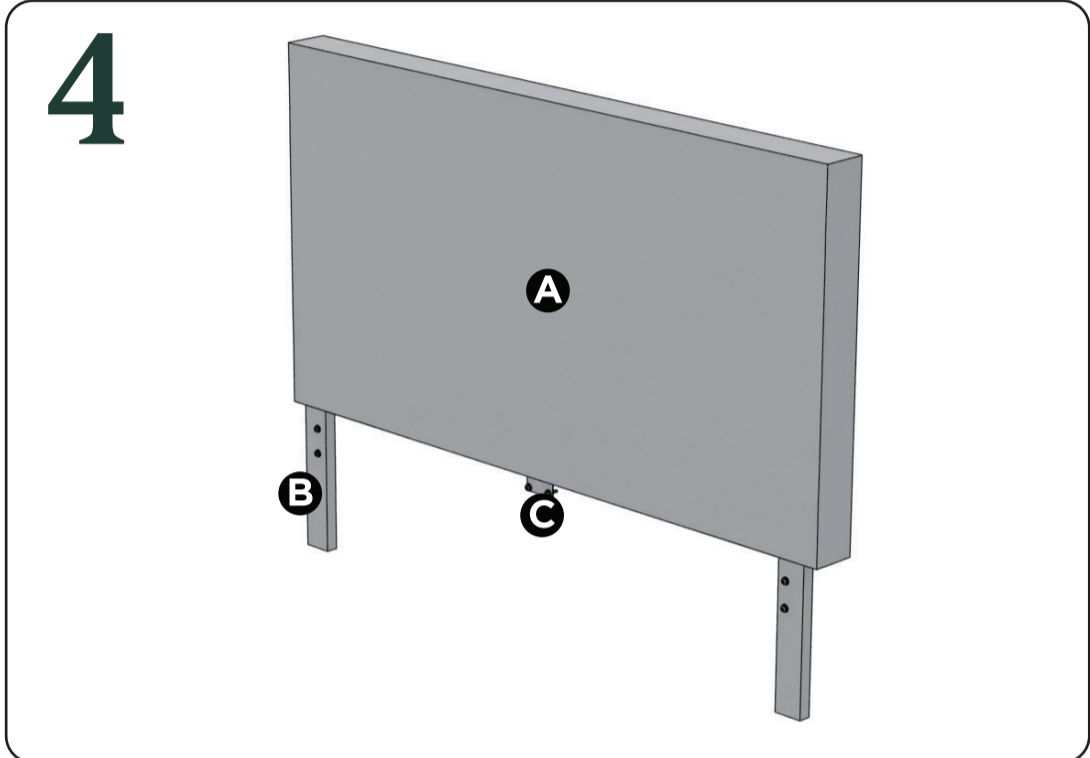
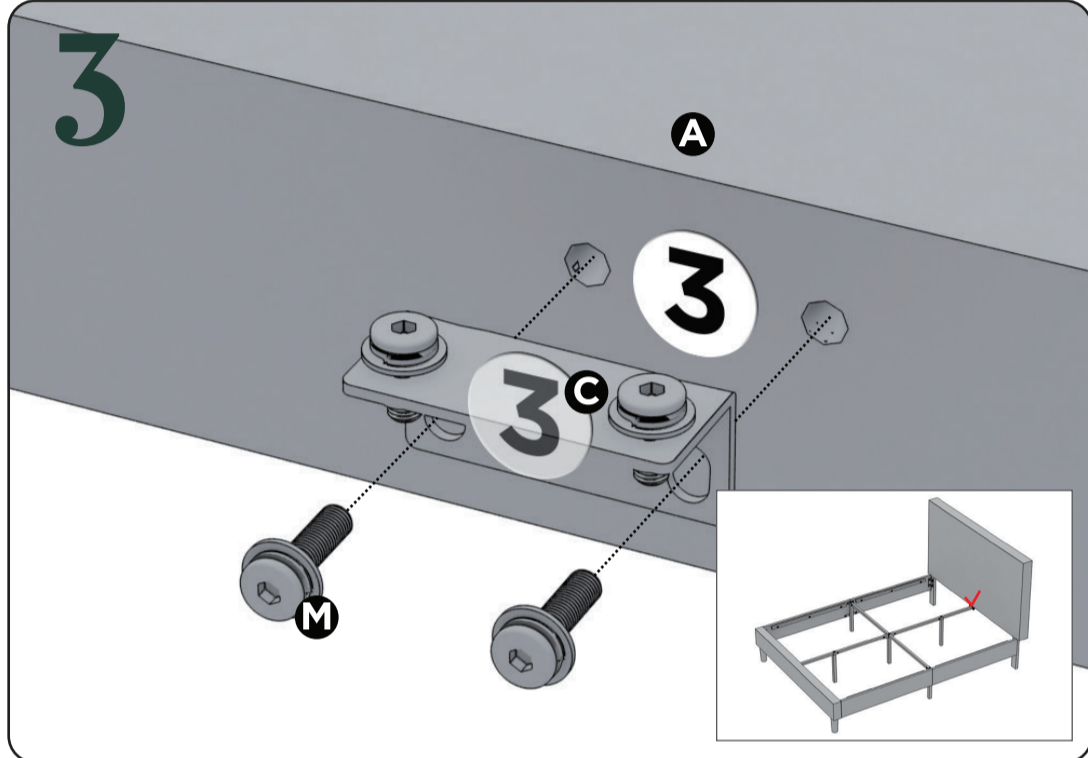
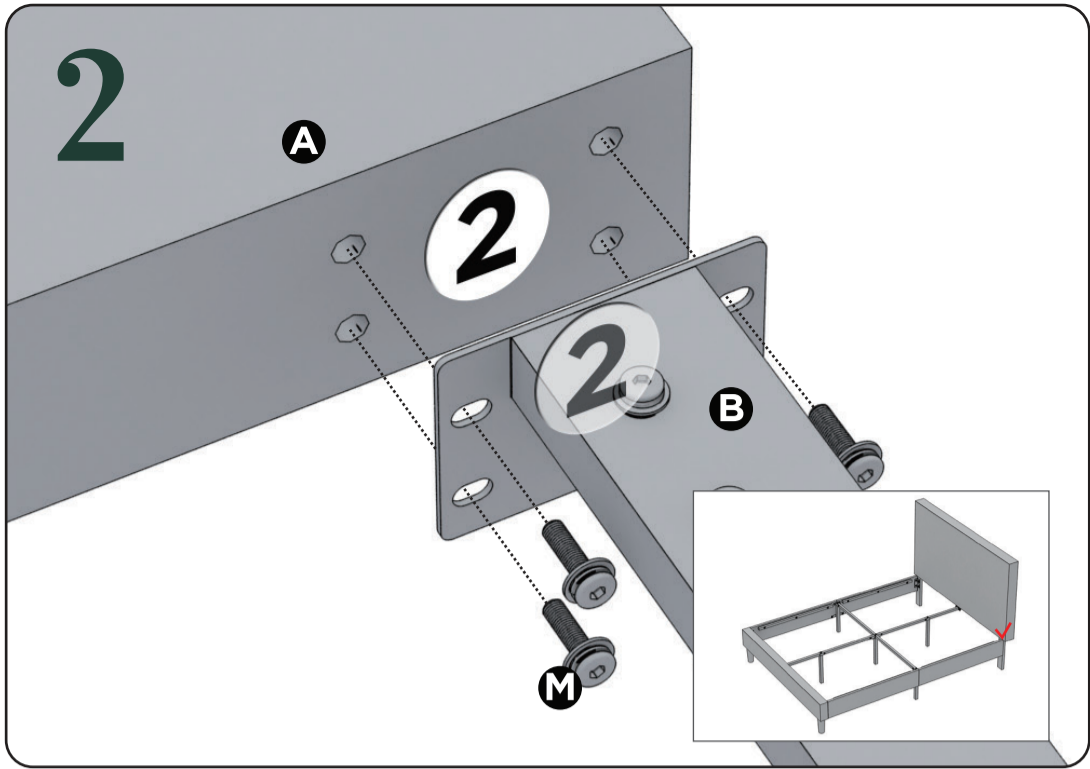
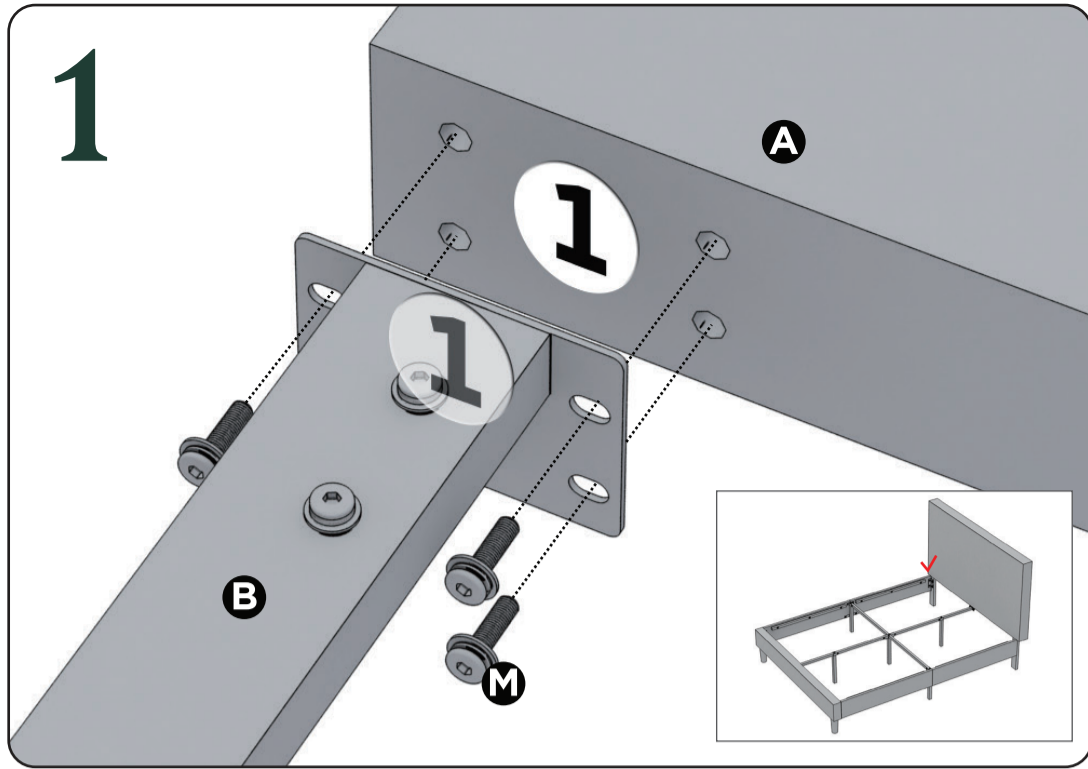

9

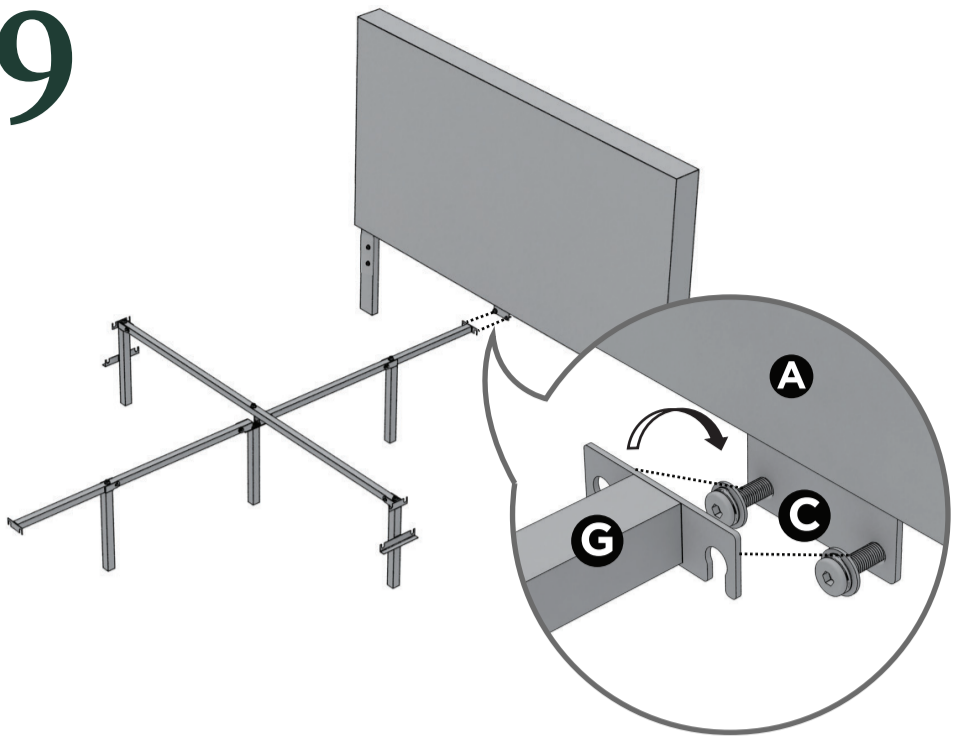

10

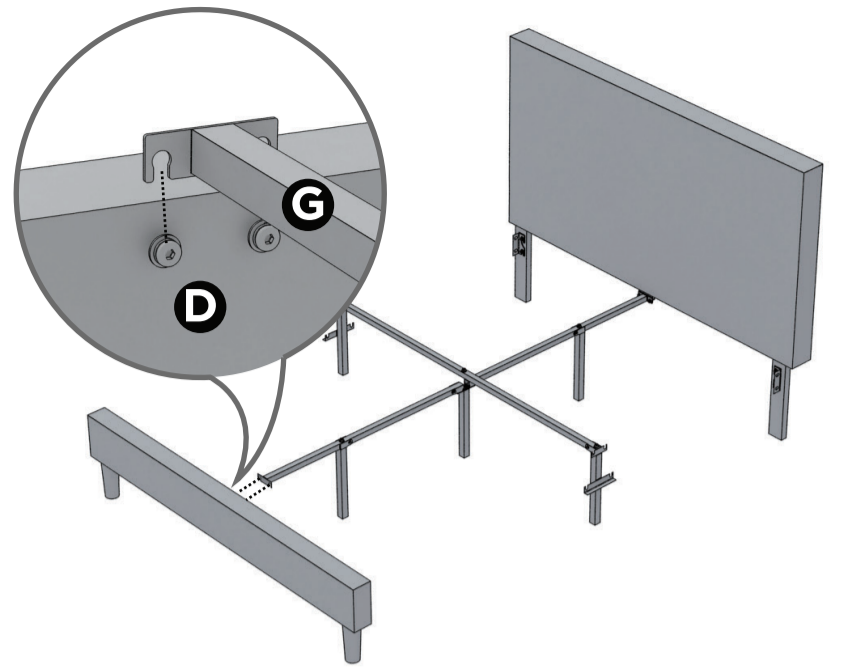

11

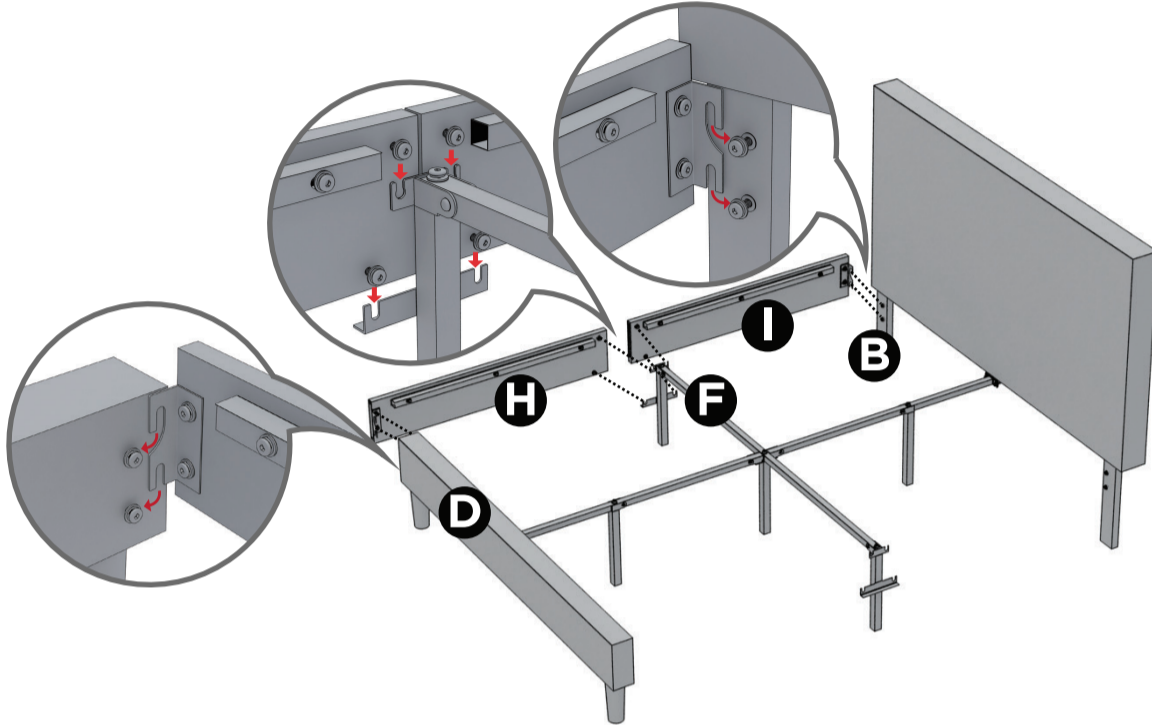

12

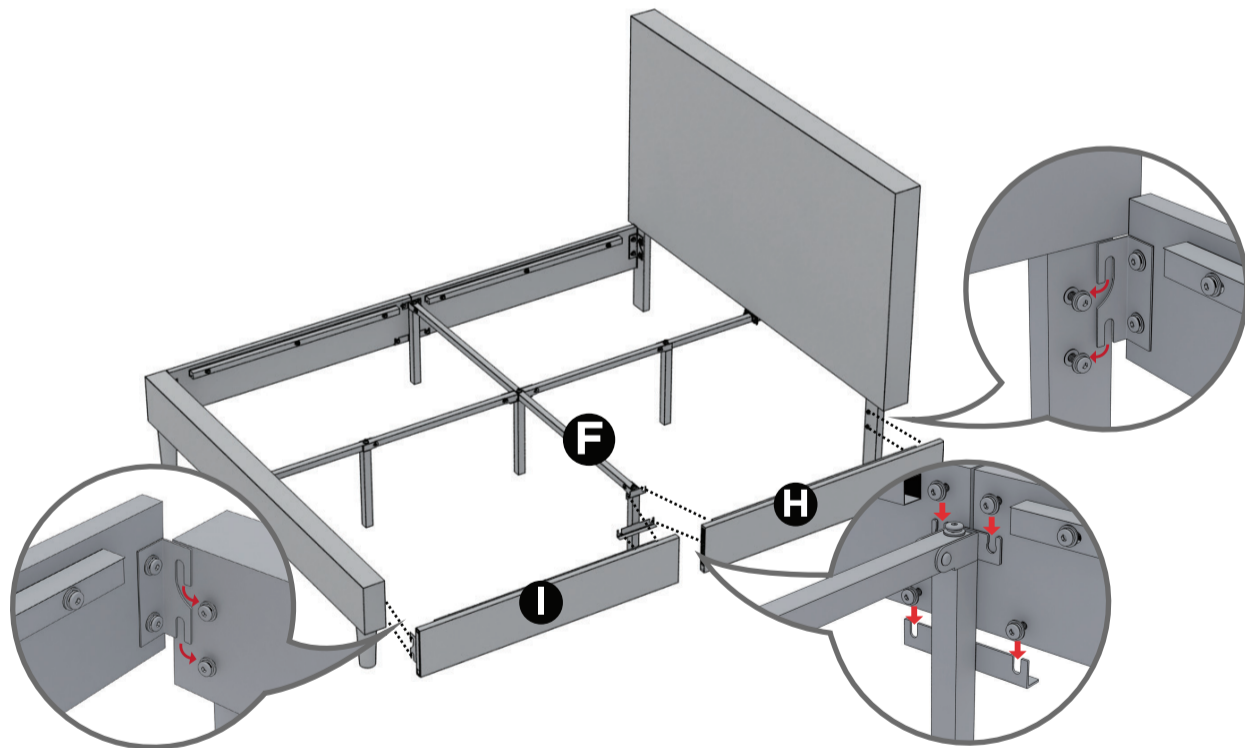

13

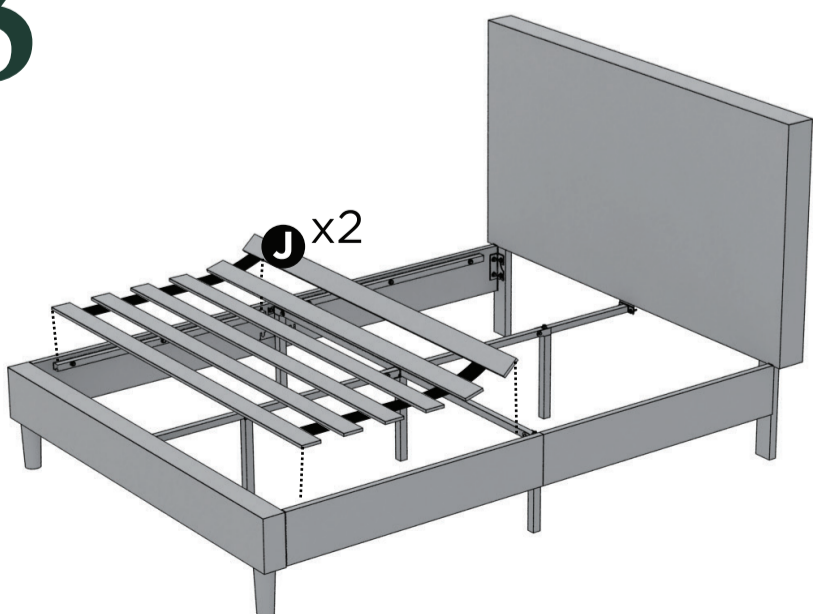

14

