

User Manual of Product 1:

Fire Sense 60262 Portable Patio Heater Outdoor Tabletop
Lightweight Propane 10,000 BTU Auto-Shutoff Valve CSA
Approved - Stainless Steel

Comfort, Quality & Style Since 1998

FireSense®

Outdoor Tabletop Heater

Item#: 60262, 61322



DANGER

FOR YOUR SAFETY:
If you smell gas:
1. Shut off gas to the appliance.
2. Extinguish any open flame.
3. If odor continues, keep away from the appliance and immediately call your gas supplier or fire department.

WARNING

Do not store or use gasoline or other flammable vapors and liquids in the vicinity of this or any other appliance. An LP-cylinder not connected for use shall not be stored in the vicinity of this or any other appliance.

DANGER

DANGER indicates an imminently hazardous situation which, if not avoided, will result in death or serious injury.

WARNING

Improper installation, adjustment, alteration, service or maintenance can cause property damage, injury or death. Read the installation, operation and maintenance instructions thoroughly before installing or servicing this equipment.

DANGER

Failure to comply with the precautions and instructions provided with this heater can result in death, serious bodily injury and property loss or damage from hazards of fire, explosion, burn, asphyxiation, and/or carbon monoxide poisoning. Only persons who can understand and follow the instructions should use or service this heater.

WARNING

FOR OUTDOOR USE ONLY!

WARNING

This product can expose you to chemicals including Carbon Monoxide, Lead, Chromium (hexavalent compounds), Di(2-ethylhexyl)phthalate (DEHP) and Diisononyl phthalate (DINP), which are known to the State of California to cause cancer and birth defects or other reproductive harm. For more information, go to www.P65Warnings.ca.gov.



ATTACH YOUR RECEIPT HERE

Keep a copy of your proof of purchase or order confirmation which will be needed if you need to contact us about warranty coverage.

Serial No. _____

Purchase Date _____



Questions, problems, missing parts?

Before returning to your retailer, our Florida-based customer service is available.

Call toll-free **(866) 985-7877** 9 a.m. – 9 p.m., EST

Email **cservice@welltraveled.net**

Live chat **www.balkenhome.com** 9 a.m. – 6 p.m., EST, Monday – Friday



TABLE OF CONTENTS

Before You Begin	Page 2
Safety Information	Page 3
Package Contents	Page 4
Hardware Contents	Page 4
Assembly	Page 5-7
Operating Instructions	Page 8-11
Care and Maintenance	Page 12
Troubleshooting	Page 13
Warranty Information	Page 14



BEFORE YOU BEGIN

Please read and understand this entire manual before attempting to assemble, operate or install this appliance. If you have any questions regarding the product, please contact Customer Service.

This manual contains important information about the assembly, operation and maintenance of this patio heater. General safety information is presented in the first few pages and is also located throughout this manual. Keep this manual for future reference and to educate new users of this appliance. This manual should be read in conjunction with the labeling on the appliance. Safety precautions are essential when any mechanical or propane-fueled equipment is involved. These precautions are necessary when using, storing, and servicing. Using this appliance with the respect and caution demanded will reduce the possibilities of personal injury or property damage. The symbols shown on page 3 are used extensively throughout this manual. Always heed these precautions, as they are essential when using any mechanical or propane-fueled equipment.



DANGER

EXPLOSION—FIRE HAZARD

- Keep solid combustibles, such as building materials, paper, or cardboard a safe distance away from the heater as recommended by the instructions.
- Provide adequate clearances around air openings into the combustion chamber.
- Never use the heater in spaces which do or may contain volatile or airborne combustibles, or products such as gasoline, solvents, paint thinner, dust particles, or unknown chemicals.
- During operation, this appliance can be a source of ignition. Keep heater area clear and free from combustible materials, gasoline, paint thinner, cleaning solvents and other flammable vapors and liquids. Do not use heater in areas with high dust content. Minimum heater clearances from combustible materials: 18 inches (1.5 feet) from top and 24 inches (2 feet) from sides.
- Never store propane near high heat, open flames, pilot lights, direct sunlight, other ignition sources or where temperatures exceed 120°F (49°C).
- Propane vapors are heavier than air and can accumulate in low places. If you smell gas, leave the area immediately.
- Never install or remove a propane cylinder while the heater is lighted, near flame, pilot lights, or other ignition sources or while heater is hot to the touch.
- This heater is red hot during use and can ignite flammables too close to the burner. Keep flammables at least 1.5 ft (18 in) from top and 2 ft (24 in) from sides. Keep gasoline and other flammable liquids and vapors well away from heater.
- Store the propane cylinder outdoors in a well ventilated space out of the reach of children. Never store the propane cylinder in an enclosed area (house, garage, etc.). If heater is to be stored indoors, disconnect the propane cylinder for outdoor storage.

WARNING: FOR OUTDOOR USE ONLY

CARBON MONOXIDE HAZARD

This appliance can produce carbon monoxide which has no odor. Using it in an enclosed space can kill you. Never use this appliance in an enclosed space such as a camper, tent or home.

DANGER

CARBON MONOXIDE HAZARD

- This heater is a combustion appliance. All combustion appliances produce carbon monoxide (CO) during the combustion process. This product is designed to produce extremely minute, non-hazardous amounts of CO if used and maintained in accordance with all warnings and instructions. Do not block the air flow into or out of the heater.
- Carbon Monoxide (CO) poisoning produces flu-like symptoms, water eyes, headaches, dizziness, fatigue, and possibly death. You can't see or smell it. It is an invisible killer. If these symptoms are present during operation of this product, get fresh air immediately!
- For outdoor use only.
- Never use inside house or other unventilated or enclosed areas.
- This heater consumes air (oxygen). Do not use in unventilated or enclosed areas to avoid endangering your life.

WARNING

BURN HAZARD

- Never leave heater unattended when hot or in use.
- Keep out of reach of children.

WARNING

WARNING indicates an imminently hazardous situation which, if not avoided, will result in death or serious injury.

WARNING

Certain materials or items, when stored under the heater, will be subject to radiant heat and could be seriously damaged.

CAUTION

SERVICE SAFETY

- Keep all connections and fittings clean. Make sure propane cylinder valve outlet is clean.
- During set up, check all connections and fittings for leaks using soapy water, never use a flame to check for leaks.
- Use as a heating appliance only. Never alter in any way to use with any device.

CAUTION

CAUTION indicates an imminently hazardous situation which, if not avoided, may result in minor or moderate personal injury, or property damage.

WARNING

- This product is fueled by propane gas. Propane gas is invisible, odorless, and flammable. An odorant is normally added to help detect leaks and can be described as having a "rotten egg" smell. The odorant can fade over time so leaking gas is not always detectable by smell alone.
- Propane gas is heavier than air and leaking propane will sink to the lowest level possible. It can ignite by ignition sources including matches, lighters, sparks or open flames of any kind many feet away from the original leak. Use only propane gas set up for vapor withdrawal.
- Store propane gas in compliance with local ordinances and codes or with ANSI/NFPA 58.
- Turn off propane when not in use.
- Alert children and adults to the hazards of high surface temperatures. Stay away from these surfaces to avoid burning skin or igniting clothing.
- Carefully supervise young children when in the vicinity of the heater.
- Do not hang clothing or any other flammable materials from the heater, or place near the heater.
- Replace any guard or protective device removed for servicing the appliance prior to placing back in service.
- Installation and repair should be done by a qualified service person. The heater should be inspected before each use and by a qualified service person at least annually. More frequent cleaning may be required as necessary. It is imperative that the control compartment, burners, and circulating air passageway of the appliance be kept clean.

PACKAGE CONTENTS



Note: Most hardware is pre-assembled in the unit. Some must be removed and replaced to assemble. Hardware listed in **BOLD** must be installed during initial setup.

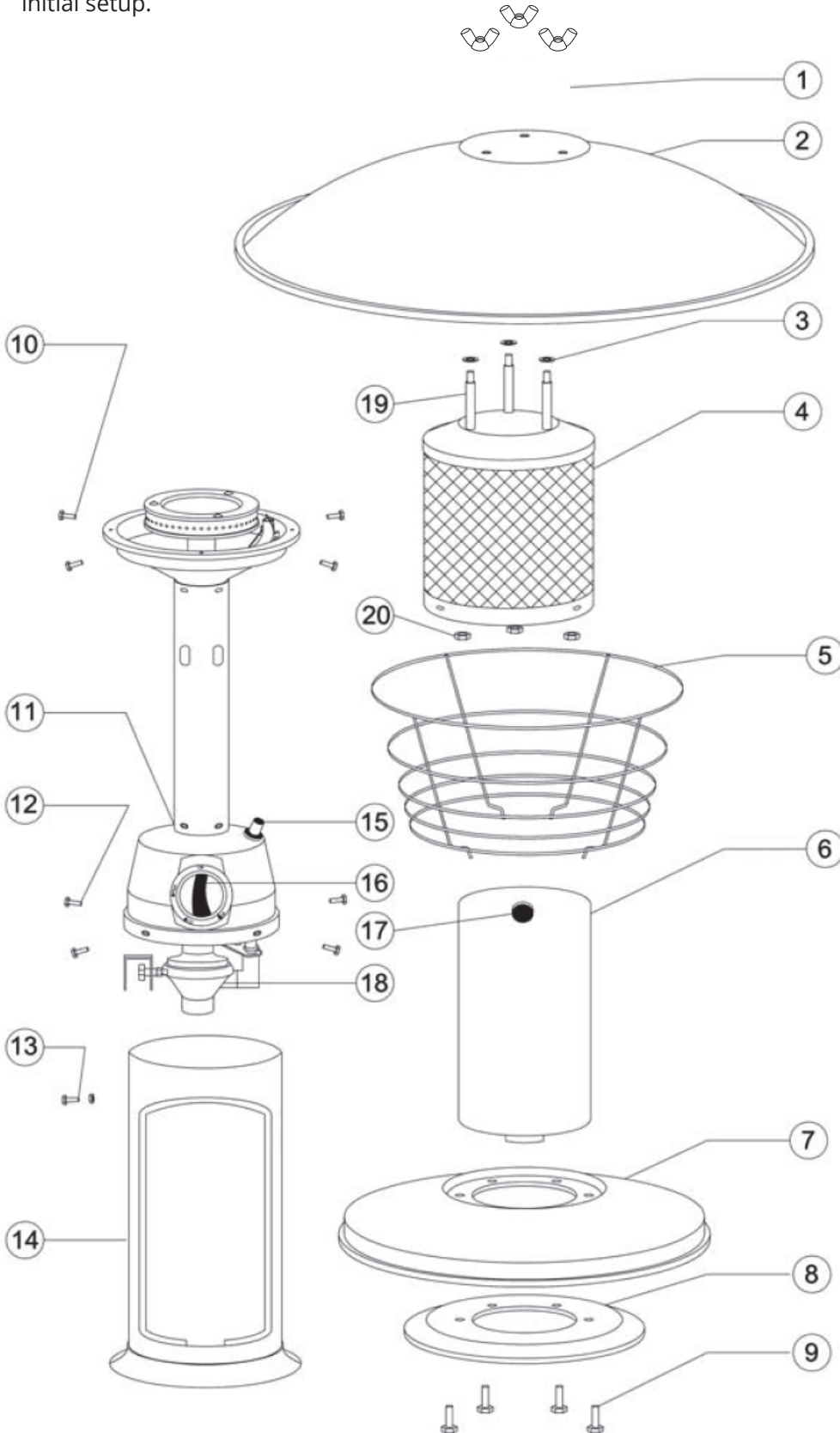

PART	DESCRIPTION	QTY
1	Wing Nut	3
2	Reflector	1
3	6mm Washer	3
4	Emitter Screen	1
5	Guard	1
6	Door Plate	1
7	Base	1
8	Cast Iron Weight	1
9	M5x25mm Bolt	4
10	M5x8mm SS Bolt	4
11	Burner	1
12	M5x8mm Bolt	4
13	M5x12mm Bolt	1
14	Tank Housing	1
15	Igniter Button	1
16	Control Knob	1
17	Handle	1
18	Regulator	1
19	60mm Stud	3
20	M5 Nut	4

Hardware Package List	QTY
Wing Nut	3
6mm Washer	3
M5x25 Bolt	4
M5x8 Bolt	4
M5 Nut	5
60mm Stud	3
M5x8 SS Bolt	4
Wrench	1
M5x12 Bolt	1

ASSEMBLY



Before beginning assembly of this appliance, make sure all parts are present. Compare all parts with package contents list and hardware contents as listed on the previous page. If any part is missing or damaged, do not attempt to assemble this product. Contact customer service for replacement parts.

ESTIMATED ASSEMBLY TIME: 30 minutes

Tools Required for Assembly (NOT included):

- Phillips screwdriver w/medium blade
- Slip joint/adjustable pliers
- Adjustable wrench (2)

STEP 1



Remove all parts of the heater from the packaging. (**NOTE:** Plastic ring on tank housing should already be in place but if not, slide the plastic ring over the bottom of tank housing.)



STEP 2

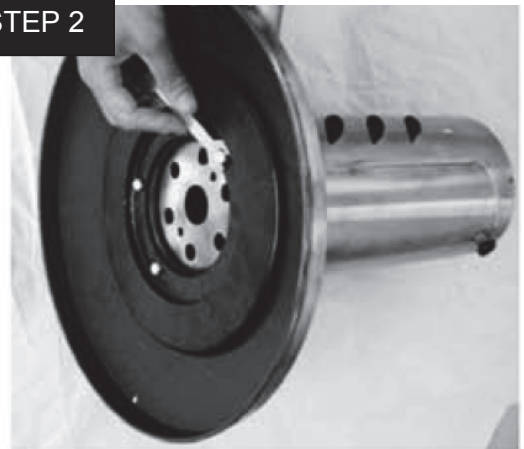

Use 4 M5x25 Bolts to fix the tank housing to the base and cast iron weight(**Note:** weight is preassembled to base),then fasten with 4 M5 nuts from the inside of the tank housing.

Use Wrench to tighten the bolts and nuts as shown above.

STEP 3



Place the Burner on the Tank Housing, then join them using 4 M5x8 Bolts.

STEP 4

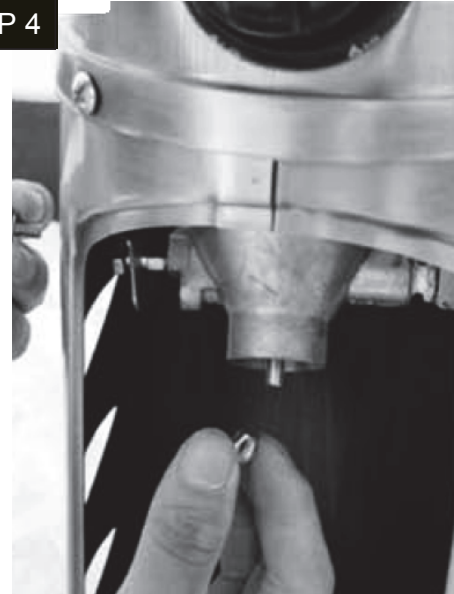

Fix the Regulator to the Tank Housing using a M5x12mm Bolt and M5 Nut.

STEP 5

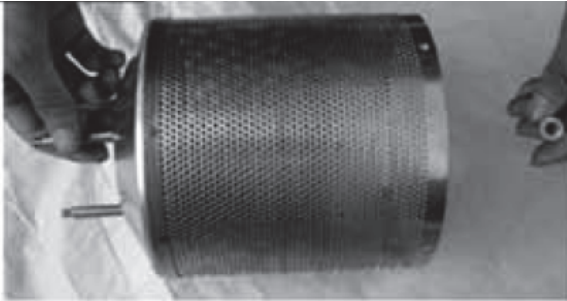

Insert a 60mm Stud into each of the 3 holes at the top of the Emitter Screen.

STEP 6



Place the Emitter Screen on the Burner. Use 4 M5x8 SS Bolts to connect the Emitter Screen to the Burner. Tighten the Bolts.

STEP 7



Lower the Guard over the Emitter Screen and insert the feet of the Guard into the holes near the edge of the Burner.

STEP 8

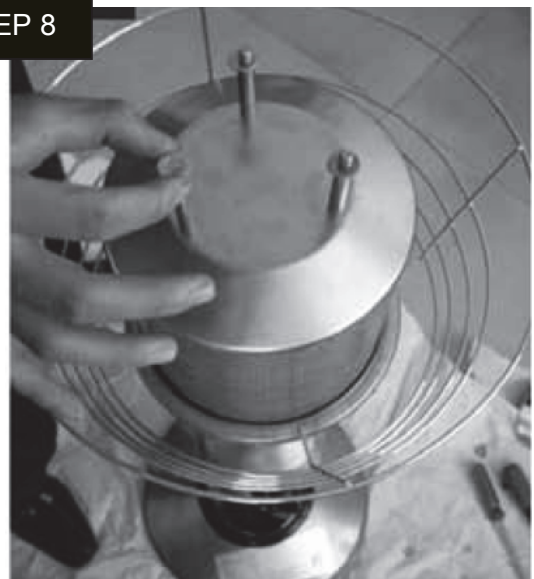

Place a Washer on each of the 3 Studs.

STEP 9



Lower the Reflector onto the Studs to rest on the Washers.

STEP 10



Secure the Reflector with 3 Wing Nuts.

STEP 11



Turn the Control Knob on the Burner to OFF. Connect the 1.02 lbs. gas tank (not included) to the Regulator (twist the gas tank clockwise into the Regulator until tightened).

STEP 12



Close the Door Plate and lock it with the handle (rotate the handle 90 degrees).



Read and become familiar with this entire manual, especially the following precautions:

Caution: This appliance is for outdoor use only (outside any enclosure). Always make sure there is fresh air ventilation.

- Use only outdoors in a well ventilated space. Never use in a building, garage or any other enclosed area.
- Always maintain at least 18" clearance (top) and 24" clearance (sides) from combustible materials.
- Always place heater on a hard and level surface.
- Do not use if the wind velocity is greater than 10 miles per hour.
- Unit will operate at decreased efficiency below 40°F (5°C).
- Keep sprinklers and other water sources away from burner and controls.
- Always use extreme caution when near heater. Alert both children and adults to the hazards of high temperatures, especially to avoid burns or clothing catching fire.
- Young children and pets should be carefully supervised when they are in the area of heater.
- Do not place clothing or other flammable materials on or near heater.
- Any guard or other protective device removed for servicing the heater must be replaced prior to operating the heater.
- Certain materials or items, when stored under heater, will be subjected to radiant heat and could be seriously damaged.
- Do not alter heater in any manner.
- Inspect heater before each use. If a damaged part is detected, do not operate until an original equipment replacement part has been properly installed. Use of unauthorized parts will void warranty and create an unsafe condition.
- Do not attempt to use this appliance without a functional factory supplied gas regulator in place. If regulator becomes damaged, use only a factory supplied replacement.
- Prior to operating heater, replace any guards or protective devices removed for servicing.
- During operation, do not touch burner assembly. The surface of heater's emitter can reach temperatures approaching 1600°F.
- After shutdown, do not touch burner assembly until heater has cooled completely (approximately 45 minutes after use).



TABLETOP HEATER LOCATION

- The tabletop heater is for outdoor use only. Always ensure that adequate fresh air ventilation is provided.
- Always maintain proper clearance to combustible materials, i.e. top 18" and sides 24" minimum.
- Tabletop heater must be located on a stable and strong surface.
- Never operate heater in an explosive atmosphere such as in areas where gasoline or other flammable liquids or vapors are stored.

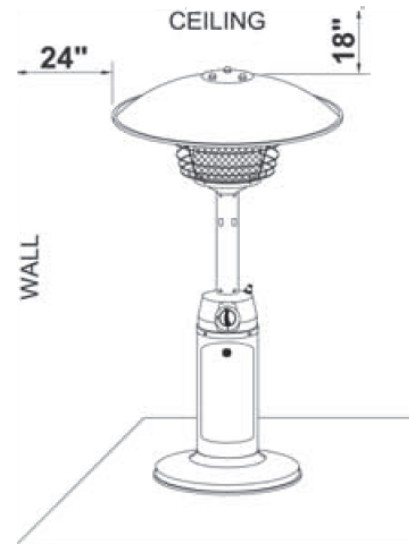

LEAK TEST

1. Make 2-3 oz. of leak test solution (one part liquid dish washing detergent and three parts water).
2. Apply several drops of solution where hose attaches to regulator.
3. Apply several drops of solution where regulator connects to cylinder.
4. Make sure all patio heater valves are OFF.
5. Turn cylinder valve ON.

WARNING

- Perform all leak tests outdoors.
- Extinguish all open flames.
- NEVER leak test when smoking
- Do not use heater until all connections have been leak tested and show no signs of leakage.

IF BUBBLES APPEAR AT ANY CONNECTION, THERE IS A LEAK.

1. Turn cylinder valve OFF.
2. If leak is detected at hose/regulator connection, tighten connection and perform another leak test. If bubbles continue to appear, contact Customer Service.
3. If leak is detected at regulator/cylinder valve connection, disconnect, reconnect, and perform another leak test. If you continue to see bubbles after several attempts, cylinder valve is defective. Contact Customer Service.

IF NO BUBBLES APPEAR AT ANY CONNECTION, THE CONNECTIONS ARE SECURE.

Note: Whenever gas connections are loosened or removed, you must perform a complete leak test.

BEFORE TURNING GAS SUPPLY ON:

1. Your heater was designed and approved for **OUTDOOR use only**. Do NOT use it inside a building, garage, or any other enclosed area.
2. Make sure surrounding areas are free of combustible materials, gasoline, and other flammable vapors or liquids.
3. Ensure that there is no obstruction to air ventilation. Be sure all gas connections are tight and there are no leaks.
4. Be sure the cylinder is clear of debris. Be sure any component removed during assembly or servicing is replaced and fastened prior to starting.

BEFORE LIGHTING:

1. Heater should be thoroughly inspected before each use, and by a qualified service person at least annually. If re-lighting a hot heater, always wait at least 5 minutes.
2. Inspect the hose assembly for evidence of excessive abrasion, cuts, or wear. Suspected areas should be leak tested. If the hose leaks, it must be replaced prior to operation. Only use the replacement hose assembly specified by the manufacturer.



OPERATION CHECKLIST:

For a safe and pleasant heating experience, perform this check before each use:

BEFORE OPERATING:

- I am familiar with entire owner's manual and understand all precautions noted.
- All components are properly assembled, intact and operable.
- No alterations have been made.
- All gas connections are secure and do not leak.
- Wind velocity is below 10 mph.
- Heater is for use outdoors (outside any enclosure).
- There is adequate fresh air ventilation.
- Heater is away from gasoline or other flammable liquids or vapors.
- Heater is away from windows, air intake openings, sprinklers and other water sources.
- Heater is at least 18" on top and at least 24" on all sides from combustible materials.
- Heater is on a hard and level surface.
- There are no signs of spider or insect nests in heater orifices.
- All burner passages are clear.
- All air circulation passages are clear.
- Clothing or other protective material should not be hung from the heater, or placed on or near the heater.
- Any guard or other protective device removed for servicing the heater must be replaced prior to operating the heater.
- Installation and repair should be done by a qualified service person. The heater should be inspected before each use and at least annually by a qualified service person.

OPERATION INFORMATION AND SAFETY:

- Unit will operate at reduced efficiency below 40°F.
- Children and adults should be alerted to the hazards of high surface temperatures and should stay away to avoid burns or clothing ignition.
- Young children should be carefully supervised when they are in the area of the heater.
- More frequent cleaning may be required as necessary. It is imperative that control compartment burner and circulating air passageways of the heater be kept clean and free of debris and/or spider or insect nests.

WARNING

FOR YOUR SAFETY
Heater will be hot after use. Handle with extreme care.



SHUT DOWN:

1. Turn control knob clockwise to OFF while depressing the knob. (Burner may make a slight popping noise when extinguished).
2. Disconnect gas tank when heater is not in use.

NOTE: After use, some discoloration of the emitter screen is normal.



AFTER OPERATION:

1. Gas control knob is in OFF position.
2. Gas tank valve is OFF.
3. Disconnect gas line.
4. Heater is stored upright in a secure location.

OPERATING INSTRUCTIONS



Inspect the heater before each operation.

Before Turning Gas Supply ON

Your heater was designed and approved for OUTDOOR USE ONLY. DO NOT use it inside a building, garage or any other enclosed area.

Make sure surrounding areas are free of combustible materials, gasoline and other flammable liquids.

- Ensure that there is no obstruction to air ventilation.
- Be sure all gas connections are tight and there are no leaks.
- Be sure the access panel is clear of debris.
- Be sure any component removed during assembly or servicing is replaced prior to starting.

Before Lighting

Heater should be thoroughly inspected before each use and by a qualified service person at least annually. If relighting a hot heater, always wait at least 5 minutes for gas to dissipate.



Lighting

1. Make sure control knob is in the “Off” position.
2. Push in and rotate the gas control knob to “Pilot” position. Depress gas control knob for 30 seconds to allow air to purge. Once gas reaches burner, depress igniter button while holding gas control knob in.
3. Once burner is lit, hold control knob in for at least 30 seconds and release.
4. If burner does not stay lit, turn control knob to “Off” position. Wait 5 minutes, then repeat Steps 2 and 3.
5. Once burner is lit, rotate control knob to desired heating level.

If you experience any ignition problem, turn off the heater and gas supply and consult the “Troubleshooting” section of this manual.

CAUTION

Avoid inhaling fumes emitted during heater’s first use. Smoke/odor from burning of oils used in manufacturing will appear. Any smoke/odor should dissipate after approximately 30 minutes. The heater should NOT produce thick black smoke.

NOTE: The burner may be noisy when initially turned on. To eliminate excessive noise from the burner, turn the control knob to LO position briefly. Then, turn the knob to level of heat desired.

NOTE: After use, some discoloration of the emitter screen is normal.

When heater is ON:

Emitter screen will become bright red due to intense heat. The color is more visible at night. Burner will display tongues of blue and yellow flame. These flames should not produce thick black smoke, indicating an obstruction of airflow through the burners. If excessive flame is detected, turn off heater and gas supply. Consult the “Troubleshooting” section.

Re-lighting

NOTE: For your safety, control knob cannot be turned to “Pilot” without first depressing control knob in “Off” position and then rotating to “Pilot”.

1. Turn gas control knob to “Off”.
2. Wait 5 minutes to let gas dissipate before attempting to relight burner.
3. Repeat the “Lighting” steps 2 and 3.

Shut Down

1. Turn control knob clockwise to OFF while depressing the knob.
(Burner may make a slight popping noise when extinguished).
2. Disconnect gas tank when heater is not in use.

After Operation

1. Gas control knob is in OFF position.
2. Gas tank valve is OFF.
3. Unscrew gas canister.
4. Store heater upright in a secure location.



To enjoy years of outstanding performance from your heater, make sure you perform the following maintenance activities on a regular basis:

KEEP EXTERIOR SURFACES CLEAN.

1. Use soapy water for cleaning. Never use flammable or corrosive cleaning agents.
2. While cleaning your unit, be sure to keep the area around the burner and control compartment dry at all times. Do not submerge the control valve assembly. If the gas control is submerged in water, do NOT use it. It must be replaced.
3. Air flow must be unobstructed. Keep controls, burner, and circulating air passageways clean. Signs of possible blockage include:
 - Gas odor with extreme yellow tipping of flame.
 - Heater does NOT reach the desired temperature.
 - Heater glow is excessively uneven.
 - Heater makes popping noise.
 - Spiders and insects can nest in burner or orifices. This dangerous condition can damage heater and render it unsafe for use. Clean burner holes by using a heavy-duty pipe cleaner. Compressed air may help clear away smaller particles.
 - Carbon deposits may create a fire hazard. Clean reflector and emitter screen with warm soapy water if any carbon deposits develop.

Note: In a salt-air environment (such as near an ocean), corrosion occurs more quickly than normal. Frequently check for corroded areas and repair them promptly.



TIP FOR STAINLESS STEEL MODELS:

Use high-quality automobile wax to help maintain the appearance of your heater. Apply to exterior surfaces below the burner.

DO NOT apply to emitter screen, burner, or reflector.

WARNING

FOR YOUR SAFETY

- Do NOT touch or move heater for at least 45 minutes after use.
- Reflector is hot to the touch.
- Allow reflector to cool before touching.

STORAGE:

Between uses:

- Turn control knob OFF.
- Disconnect LPG source.
- Store heater upright in an area sheltered from direct contact with inclement weather (such as rain, sleet, hail, snow, dust and debris).
- If desired, cover heater to protect exterior surfaces and to help prevent build-up in air passages. Never leave LPG tank exposed to direct sunlight or excessive heat.

Note: Wait until heater is cool before covering.

SERVICE:

Only a qualified service person should repair gas passages and associated components.

Caution: Always allow heater to cool before attempting service.



PROBLEM	POSSIBLE CAUSE	CORRECTIVE ACTION
Pilot will not light	Fuel tank may be empty	Replace LPG canister
	Orifice blocked	Clean orifice
	Air in supply system	Purge air from lines. Open gas lines and depress control knob for 2-3 minutes.
	Loose connection	Check all fittings
Pilot won't stay on	Debris around pilot	Clean dirty area
	Lack of fuel pressure	Replace fuel canister
	Loose connections	Tighten connections
	Gas leak	Check connections
Burner won't light	Pressure is low	Replace LPG canister
	Opening blocked	Remove and clean
	Control not ON	Turn knob to ON
	Pilot light assembly bent	Place pilot properly
	Improper pilot light assembly position	Position properly and retry



Questions, problems, missing parts?

Before returning to your retailer, our exceptional customer service is available.

Call toll-free **(866) 985-7877** 9 a.m. – 9 p.m., EST
 Email **cservice@welltraveled.net**
 Live chat **www.balkenehome.com** 9 a.m. – 6 p.m., EST, Monday – Friday



by

BALKENE
— HOME —



LIMITED WARRANTY

Customers in the Contiguous US

With proof of purchase from an authorized retailer, this product is warranted for a period of 1 year from original purchase date against defects in materials and workmanship under normal use. This warranty does NOT cover normal wear/weathering, exposure to water, freezing temperatures, oils, fluids, or chemicals OR use in a commercial context if the unit is not designated as a commercial model. At Well Traveled Living's sole discretion, products under warranty will be repaired and/or replaced at no charge to the customer. Returns sent back to Well Traveled Living must be sent via prepaid freight in the original retail packaging.

For warranty service, contact Balkene Home/Well Traveled Living at the address, phone numbers or website and email listed in this owner's manual. Be sure to have your sales receipt, date of purchase and catalogue/model numbers available when calling. All warranty service will be coordinated by Well Traveled Living's Amelia Island, Florida service center. This warranty is extended only to the original owner. Proof of purchase will be required before warranty service is rendered. The sales receipt is the only valid proof of purchase. This warranty only covers failures due to defects in materials or workmanship which occur during normal use. Failures and/or damage which result from accident, negligence, misuse, abuse, neglect, mishandling, alteration or modification, failure to maintain, improper assembly or maintenance, service by unauthorized agency or use of unauthorized components or damage that is attributable to acts of God are NOT covered.

This limited warranty gives you specific legal rights and you may also have other rights which vary from jurisdiction to jurisdiction. The provisions of the United Nations Convention on Contracts for the Sales of Goods shall not apply to this limited warranty or the sale of products covered by this limited warranty.

- THERE ARE NO EXPRESS WARRANTIES EXCEPT AS LISTED.
- PURCHASER ASSUMES ALL RISKS IN THE ASSEMBLY AND OPERATION OF THIS UNIT.
- FAILURE TO FOLLOW WARNINGS AND OPERATIONAL INSTRUCTIONS CONTAINED IN THIS MANUAL CAN RESULT IN SEVERE PROPERTY DAMAGE AND/OR PERSONAL INJURY.
- IN NO EVENT WILL WELL TRAVELED LIVING, OR ITS DIRECTORS, OFFICERS OR AGENTS BE LIABLE TO THE PURCHASER OR ANY THIRD PARTY, WHETHER IN CONTRACT, IN TORT, OR ON ANY OTHER BASIS, FOR ANY INDIRECT, SPECIAL, PUNITIVE, EXEMPLARY, CONSEQUENTIAL, OR INCIDENTAL LOSS, COST, OR DAMAGE ARISING OUT OF OR IN CONNECTION WITH THE SALE, MAINTENANCE, USE, OR INABILITY TO USE THE PRODUCT, EVEN IF WELL TRAVELED LIVING OR ITS DIRECTORS, OFFICERS OR AGENTS HAVE BEEN ADVISED OF THE POSSIBILITY OF SUCH LOSSES, COSTS OR DAMAGES, OR IF SUCH LOSSES, COSTS, OR DAMAGES ARE FORESEEABLE. IN NO EVENT WILL WELL TRAVELED LIVING, OR ITS OFFICERS, DIRECTORS, OR AGENTS BE LIABLE FOR ANY DIRECT LOSSES, COSTS OR DAMAGES THAT EXCEED THE PURCHASE PRICE OF THE PRODUCT.
- SOME JURISDICTIONS DO NOT ALLOW THE EXCLUSION OR LIMITATION OF INCIDENTAL OR CONSEQUENTIAL DAMAGES, SO THE ABOVE LIMITATION OR EXCLUSION MAY NOT APPLY TO THE PURCHASER.

EXTEND YOUR WARRANTY

When you purchase a Fire Sense or Balkene Home product from any authorized retailer, you'll have peace of mind in knowing that it comes with a one-year warranty. Extend your warranty for *an additional year* when you review your item at balkenehome.com within 365 days of purchase.



Important Notice

Before returning to place of purchase—for customer service and warranty issues:

Call toll-free	(866) 985-7877	9 a.m. – 9 p.m., EST
Email	cservice@welltraveled.net	
Live chat	balkenehome.com	9 a.m. – 6 p.m., EST, Mon – Fri

Distributed by:
Well Traveled Living
716 S 8th Street, Amelia Island, FL 32034
balkenehome.com
cservice@welltraveled.net
(866) 985-7877