

SKU: HCC60HTR-PL-US/CA

尺寸: 105X142 MM

形式: 骑马钉 共 24 页

材质: 铜版纸128G

60A MPPT CHARGE CONTROLLER

Model: M4860N SKU: HCC60HTR-PL-US/CA

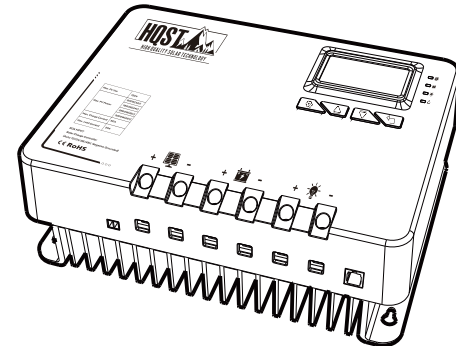

The user manual is meant to offer you a brief walkthrough of the device's features.

Please save the user manual for future reference.









Still need help? Please contact us via sales@myhq solar.com

hq solarpower.com

Download ChargePro app in Apple Store / Google Play Store

 **User Guide**

WARNINGS AND TOOLS ICON CHART

Icons	Name	Description
	High Voltage	High voltage device. Installation should be performed by an electrician.
	High Temperature	This device will produce heat. Mount device away from other items.
	Environmental Hazard	Electronic Equipment. Do not put in landfill.
	Wire Cutter	A wire cutter is needed for cutting and stripping wires prior to connection.
	Multi-meter	A multimeter is needed for testing equipment and verifying polarity of cables.
	Anti-static Glove	Anti-static gloves are recommended to prevent controller damage caused by static electricity.
	Electrical Tape	Electrical tape is recommended to safely insulate spliced or bare wires.
	Screwdriver	A common size screwdriver is needed to attach wires to the controller.

SAFETY TIPS

- Review this manual thoroughly before attempting installation.
- Beware of any nearby electrical equipment that may interfere with installing this device.
- Solar panels can generate high voltages and currents, make sure your solar panels are completely covered from sunlight during installation. It is recommended that installation be performed by a qualified electrician.
- Connecting wires to this device can generate sparks, please wear proper insulation gear while installing this device.
- To avoid damage to the battery or controller, use proper fuses in wiring. Please do not hesitate to contact the professionals if you need help with fuse sizing.
- Always keep children away from this device.
- Be certain to use the correct gauge of wire, see below for a table of recommended wire size for various current loads.

Solar Input Current	5A	10A	20A	30A	40A	60A
Wire Cross Section Area (mm ²)	1.5	2.5	5	8	10	12
Wire AWG	15	13	10	8	7	6

PRODUCT FEATURES

Thank you for choosing our products. This MPPT solar charge controller is a device for solar charge regulation and direct current output load control. This device is mainly used in small and medium sized off-grid solar power systems.

These MPPT charge controllers have features as follows:

- By continuously checking solar panel power output changes, the controllers employ multiple MPPT charge algorithms in combination to boost charging efficiency in different weather and temperature conditions.
- Built-in buffer, allows max 25% exceeding rated power input.
- Charging modes available for most common deep-cycle battery types in the market, including AGM (sealed lead acid batteries), GEL, Flooded, and Lithium.
- Built-in BT communication module for operation on mobile phone APP. For extending BT transmission distance, you can also connect external BT module (optional, not included in the package).
- Auto recognition of 12V/24V/36V/48V battery system voltage. Lithium battery excluded from this feature.
- Supports recording of system running data including power generated and power utilized for up to 300 days, compatible with monitoring App through IOS and Android.
- We have built-in BT communication module in this controller and we provide APP ChargePro for mobile phone monitoring and operation. You can search "ChargePro" and download the APP at IOS APP Store and Google Play Store.

- Provides multiple load control mode options for light based, time based and manually adjusted scenarios. Low no-load loss.
- Industrial grade design with reverse polarity protection for solar panels, battery and load.

DEVICE DIAGRAM

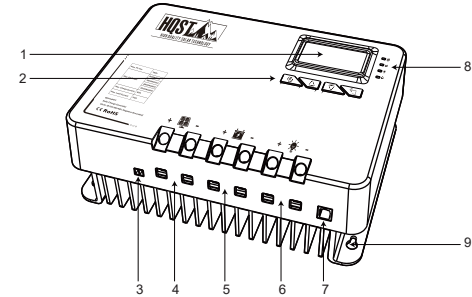

#	Description
1	LCD Display Screen
2	Function Key ([SET], [UP], [DOWN], [ESC])
3	External Temperature Sensor Terminal
4	Solar Terminals
5	Battery Terminals
6	DC Load Terminals
7	RS485 Communication Port
8	LED Indicator (PV, BAT, LOAD, FAULT)
9	Installation Mounting Holes

MOUNTING INSTRUCTION

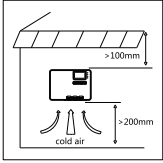

Step 1

Find a cool, dry and weather safe location for installation.

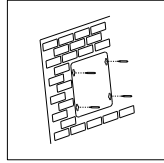

Step 2

Mark the controller's mounting holes on the mounting surface.

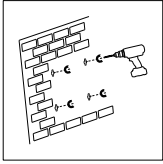

Step 3

Drill holes in the marked mounting hole location.

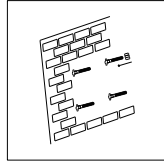

Step 4

Insert pilot screws in the mounting holes.

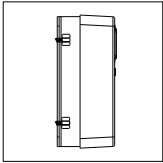

Step 5

Fasten the controller into the pilot screws.

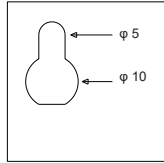

Step 6

Continue to wire battery, solar DC load and other accessories to the controller

WIRE CONNECTION SEQUENCE

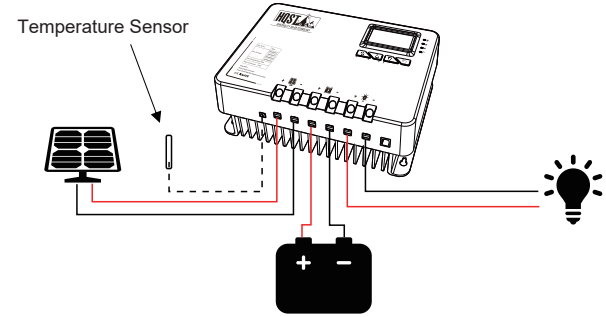

During installation of the controller, please follow the order of connection below:

1. Connect the positive battery wire followed by the negative battery wire.
2. Make sure your solar panels are fully covered to prevent electrical shock.
3. Connect the positive solar array output wire followed by the negative solar array output wire.
4. Connect DC load wires to the DC load output (if applicable).
5. Connect the external temperature sensor to its terminal shown above, and attach or stick the temperature sensor to the battery side.
6. Download APP ChargePro and turn on the BT function in the mobile phone. Testing the APP function with the controller.

Connecting to the ChargePro app (iOS/iPadOS)

(iOS/iPadOS)



Apple and the Apple logo are registered trademarks of Apple Inc

Download the **ChargePro** app (iOS/iPadOS) to set up your charge controller and monitor real-time data for enhanced charging experience.

Connecting to the ChargePro app (Android)

(Android)



Google Play and the Google Play logo are trademarks of Google LLC





Download the **ChargePro** app (Android) to set up your charge controller and monitor real-time data for enhanced charging experience.

LED LIGHT SIGNAL INTERPRETATION CHART

LED Name	LED Display	Signal Indication
PV	Off	Solar Input Not Charging *PV LED is generally off during nighttime.
	Flash	Detected PV Error-Check Error code
	Steady On	In the Charging
BATTERY	Flash	Detected Battery Error-Check Error code
	Steady On	Battery On
LOAD	Off	Load Off
	Flash	Detected Load Error-Check Error code
	Steady On	DC Load On
FAULT	Off	No Errors
	Steady On	System Error – Check Error Code

Check the Fault light to spot if a system error may be present.

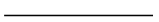
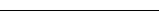
LED FLASH RHYTHM CHART

Flash Status	Indication	Description
Steady On	on  off 	LED light on.
Off	on  off 	LED light off.
Fast Flash	on  off 	LED light blinks at frequency of 2Hz (twice every second).

RS485 COMMUNICATION PORT

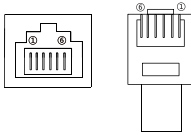

RS485 PIN (RJ12)



PIN-1	PIN-2	PIN-3	PIN-4	PIN-5	PIN-6
VDD	VDD	GND	GND	D-	D+

*Support 3.3 V,20mA

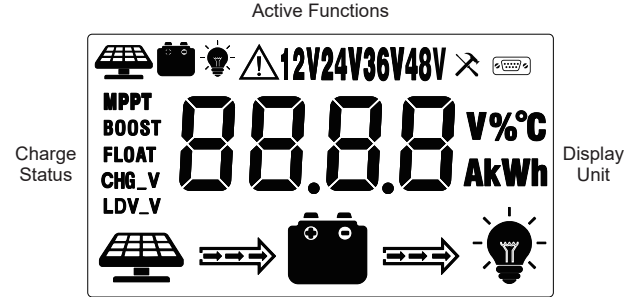



LCD DISPLAY INTERFACE OVERVIEW







LCD DISPLAY INTERFACE





Display Section	Display Layout
Charge Status	
Charge Mode & Parameter	MPPT BOOST FLOAT CHG_V LDV_V 88.88 V% AkWh
Active Functions	 12V24V36V48V

LCD STATUS INFORMATION

Status Icon	Indication	Status	Description
	Solar Charge Indication	Flowing	Solar Power Charging Battery
		Off	Solar Power Not Charging Battery
	DC Load Indication	Flowing	DC Load Drawing Power
		Off	DC Load Off
MPPT	Charge Mode	Steady On	MPPT Charge Mode
BOOST			Boost Charge Mode
FLOAT			Float Charge Mode
		Off	Not Charging
CHG_V	Voltage Setting	On	Setting Charge Voltage
		Off	Charge Voltage Has Been Set
LDV_V	Over Discharge Volt Settings	On	Setting Charge Voltage
		Off	Charge Voltage Has Been Set
	Solar Icon	Steady On	Daylight Detected
		Off	No Daylight Detected
		Flash	Solar System Over Voltage
	Battery Icon	Steady On	Battery Connected and Functional
		Off	No Battery Connection
		Flash	Battery Over-Discharged
	Load Status	Flash	DC Load Short Circuit or Over-Load
		ON	Load On
		OFF	Load Off

KEY FUNCTIONALITY CHART

Function Key	System Mode	Input	Input Function
	View Mode	Long Press	Enter SET mode
	View Mode	Short Press	View Previous Page
	View Mode	Short Press	View Next Page
	View Mode	Short Press	DC Load On/Off (Manual Control Program Only)

Function Key	System Mode	Input	Input Function
	Set Mode	Long Press	Save Data & Exit SET Mode
		Short Press	Next Setting
	Set Mode	Short Press	Increase Parameter Value
	Set Mode	Short Press	Decrease Parameter Value
	Set Mode	Short Press	Exit SET Mode Without Saving

LCD DISPLAY RULES & CYCLES

Pre start-up display cycle when the MPPT controller turns on, this usually last several seconds while controller detects operating environment.

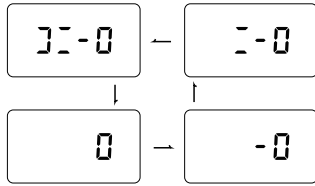

LCD Screen Display Cycle

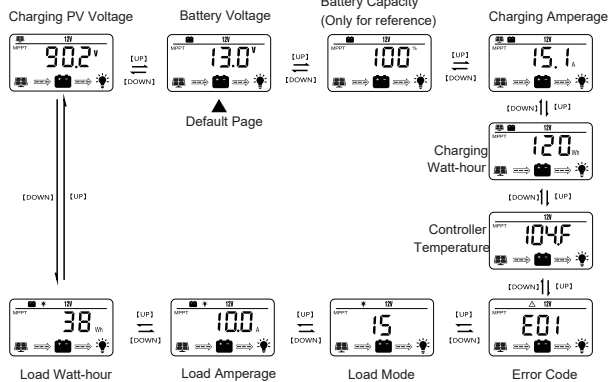

- The battery voltage view will be displayed by default. Use the up and down arrow keys to cycle through different views. The battery voltage view will resume upon 30 seconds of inactivity. The error code view will be displayed when an error is detected. The backlight in the screen will be on for 20 seconds with any button operation.

Setting Battery Mode

- Enter SET mode by pressing the Setting key in any view page other than Load Mode Or Controller Temperature. Use the up and down arrow keys to select battery mode, then long press Setting key to save.

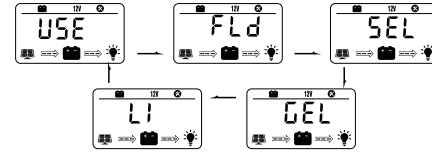

Abbreviations	Battery Types	Description
FLD	Flooded Battery	Auto-recognition with default parameters set for each type of batteries.
SEL	Sealed/AGM Battery	
GEL	Gel Battery	
LI	Lithium Battery	Low temperature protection (Frozen charge forbid). Some parameters can be customized.
USE	Advanced User Mode	Most parameters can be customized.

Advanced Battery Settings

Pressing the Setting key to enter SET mode. Choose Lithium or User mode, short press the Setting key again to cycle through each parameter view. Use the up and down arrow key to adjust parameter value, then long press Setting key to save.

For Battery Type: Li

Low Temperature Protection(Frozen Charge Forbid)

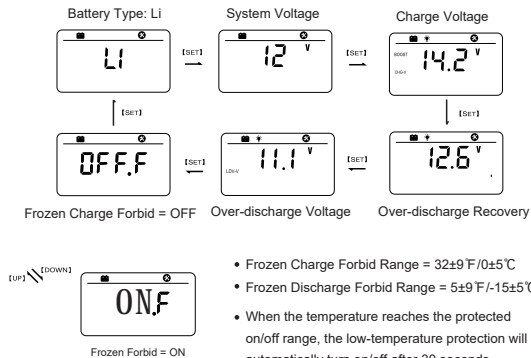

For Battery Type: USER

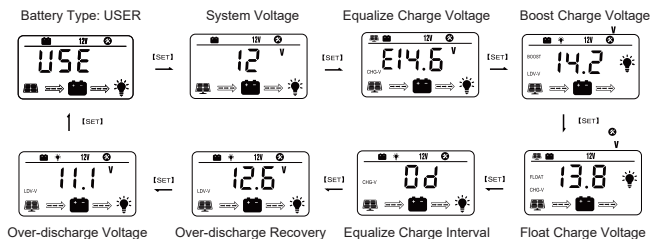

Load Mode Settings

Enter Load SET Mode by pressing the Setting key in Load Mode view only. Use the arrow key to cycle through load modes before long pressing SET to save and exit. Short pressing ESC will exit without saving.

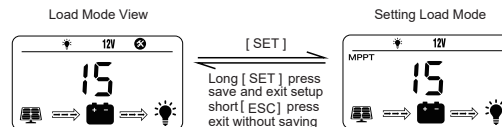

Mode	Definition	Description
0	Daylight Auto-Control	DC load turns on when no daylight is detected.
1~14	Daylight On/Timer Off	DC load turns on when no daylight is detected. DC load turns off according to timer.
15	Manual Mode	DC load turns on/off by pressing the Return key.
16	Testing Mode	DC load turns on and off in a quick succession.
17	Always On	DC load stays on.

Temperature Unit Setting

In the temperature display interface, enter the temperature unit setting mode by long pressing the setting button. You can switch between $^\circ\text{F}$ (Fahrenheit) and $^\circ\text{C}$ (Celsius) by pressing up and down arrow key. Long press the setting button to confirm saving and exit, and short press the ESC key to exit the setting without saving.

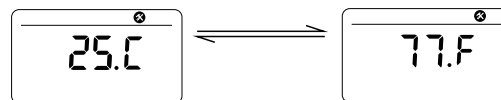

ERROR CODE CHART

Code	Error	Description & Quick Troubleshoot
E00	No Error	No action needed.
E01	Battery Over-discharged	Battery voltage is too low. DC load will be turned off until battery re-charges to recovery voltage.
E02	Battery Over-voltage	Battery voltage has exceeded controller limit. Check battery bank voltage for compatibility with controller.
E04	Load Short Circuit	DC load short circuit.
E05	Load Overload	DC load power draw exceeds controller capability. Reduce load size or upgrade to a higher load capacity controller.
E06	Overheating	Controller exceeds operating temperature limit. Ensure the controller is placed in a well-ventilated cool, dry place.
E07	Environmental Overtemperature	The environment temperature sampled by the external temperature probe is too high.
E10	Solar Over-voltage	Solar array voltage exceeds controller rated input voltage. Decrease the voltage of solar panels connected to the controller.
E14	Battery Reverse Polarity	Battery connection wires connected with reverse polarity. Disconnect and re-connect with correct wire polarity.

*Please contact professions for technical support on additional troubleshooting.

CONTROLLER SPECIFICATION

The variable “n” is adopted as a multiplying factor when calculating parameter voltages, the rule for “n” is listed as: if battery system voltage is 12V, n=1; 24V, n=2; 36V, n=3; 48V, n=4.

For example, the equalize charge voltage for a 12V FLD (Flooded) battery bank is $14.8V \times 1 = 14.8V$. The equalizing charge voltage for a 24V FLD (Flooded) battery bank is $14.8V \times 2 = 29.6V$.

Parameter	Value
Model	M4860N
System Wiring Grounded	Negative Grounded
Battery System Voltage	12V/24V/36V/48V Auto (FLD/GEL/SLD/USE) Manual (LI/USE)
No-load Loss	12ma (12V), 10ma (24V), 5ma (36V), 2ma (48V)
Max Solar Input Voltage	<150Voc
Rated Solar Charge Current	60A
Max Solar Input Power	900W/12V 1800W/24V 2600W/36V 3200W/48V
Light Control Voltage	5V*n
Light Control Delay Time	10s
Max Load Output Current	20A
Operating Temperature	-35°C ~ +45°C
IP Protection	IP32
Net Weight	4.55 kg
Communication Port	RS485
Operating Altitude	≤ 3000 meters
Controller Dimension	280*210*102.7mm

Parameter	Battery Parameters				
	FLD	SEL	GEL (default)	USE (adjustable)	LI (adjustable)
Battery Types					
Equalize Charge Voltage	14.8V*n	14.6V*n	--	Default	--
Boost Charge Voltage	14.6V*n	14.4V*n	14.2V*n	Default: GEL	Default: 14.2V*n
Float Charge Voltage	13.8V*n			Default: GEL	--
Boost Charge Recovery Voltage	13.2V*n			Default: GEL	--
Over-discharge Recovery Voltage	12.6V*n			Default: GEL	--
Over-discharge Voltage	11.1V*n			Default: GEL	Default: 11.1V*n
AutoTemperature Compensation	-3mV/2V/°C			Default: GEL	--

PRODUCT DIMENSION

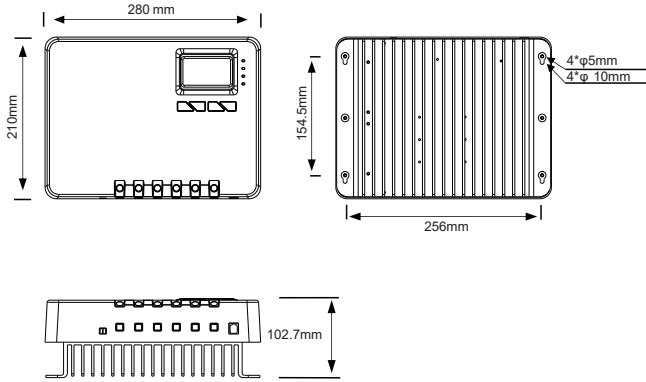

Model	M4860N
Product Dimension	280*210*102.7mm
Installation Area Dimension	256*154.5mm
Installation Hole Size	$\phi 5\text{mm}$ & $\phi 10\text{mm}$
Connection Socket Size	10*10mm

WARRANTY

- HQST products are covered by a 12-month limited warranty from the original purchase date. If any problems occur, please contact our support team.
- We only provide after-sales services for products that are sold by HQST or retailers and distributors authorized by HQST. If you have purchased your unit from other channels, please contact your seller for more information about return and warranty.

CUSTOMER SUPPORT

- If you have any questions or concerns, please send us an email at sales@myhq solar.com