

## **User Manual of Product 1:**

ASTRO Gaming A50 Wireless Gaming Headset + Charging Base Station, Game/Voice Balance Control, 2.4 GHz Wireless, 15 m Range, for Xbox Series X|S, Xbox One, PC, Mac - Black/Gold

# MDR-7506

## SERVICE MANUAL

Ver 1.1 2002.07

US Model  
AEP Model



### SPECIFICATIONS

Type	Circum-aural, closed
Driver units	40 mm dia., dynamic type
Impedance	63 ohms at 1 kHz
Sensitivity	106 dB/mW
Rated power	0.5 W
Power handling capacity	1 W
Frequency response	5 - 30,000 Hz
Cord	3 m (extended length) coiled cord with a stereo unimatch plug
Weight	Approx. 230 g (without cord)

### 1. DISASSEMBLY

**Note :** Follow the disassembly procedure in the numerical order given.

- Remove 4 pawls as illustrated below.

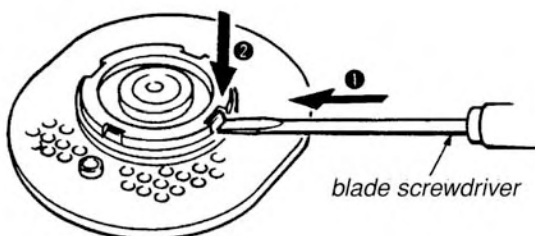

### 2. MOUNTING DIAGRAM

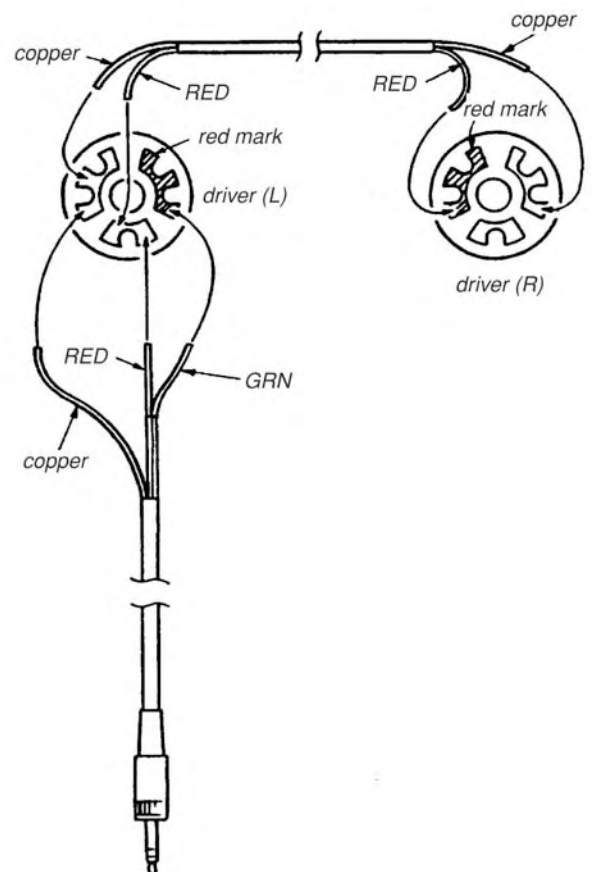

STEREO HEADPHONES

9-956-092-13  
2002G0200-1  
© 2002.07

Sony Corporation  
Personal Audio Company  
Published by Sony Engineering Corporation

SONY®

**3. EXPLODED VIEWS**

**NOTE:**

- -XX, -X mean standardized parts, so they may have some differences from the original one.
- Items marked “\*” are not stocked since they are seldom required for routine service. Some delay should be anticipated when ordering these items.

- The mechanical parts with no reference number in the exploded views are not supplied.
- Hardware (# mark) list and accessories are given in the last of this parts list.

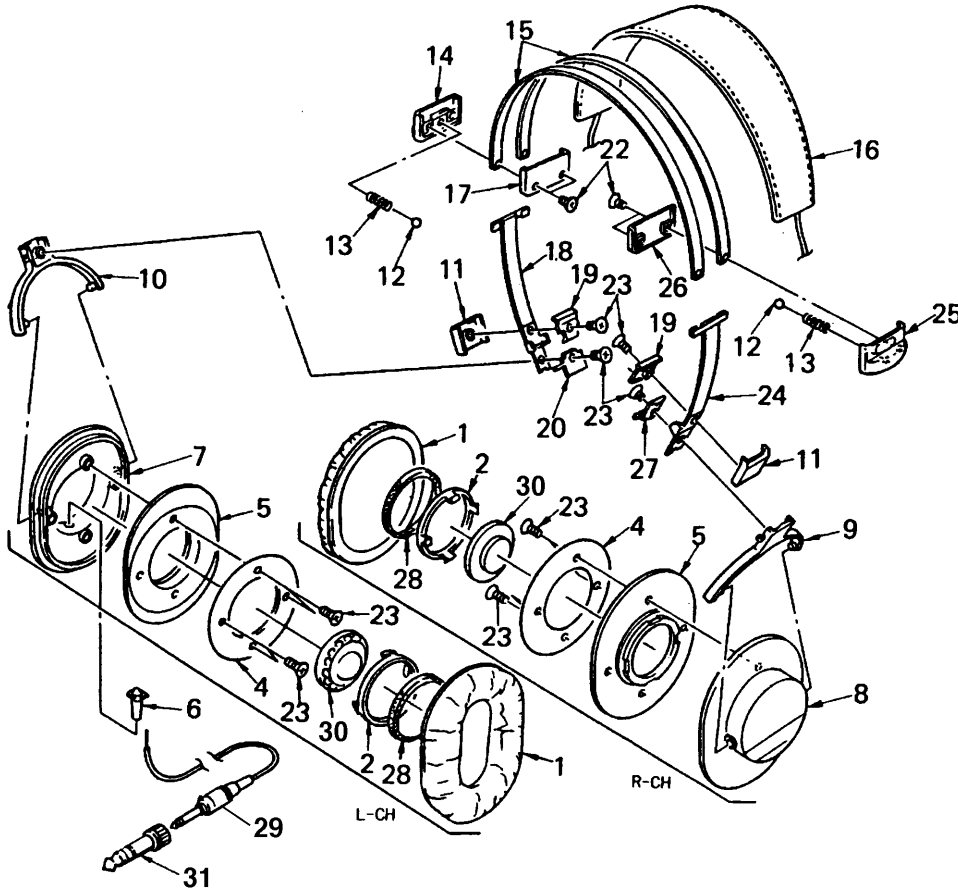

Ref. No.	Part No.	Description	Remarks	Ref. No.	Part No.	Description	Remarks
1	X-2113-124-1	PAD ASSY, EAR		19	2-113-123-11	LID, HINGE CASE	
2	2-113-129-01	STOPPER, DRIVER		20	2-113-130-11	LID (LEFT), HANGER	
* 4	2-113-152-02	REGISTER, FRONT		22	7-685-235-19	SCREW +KTP 2.6X10 TYPE2 SLIT	
* 5	2-113-140-01	PLATE, FRONT		23	7-685-232-19	SCREW +KTP 2.6X5 TYPE2NON-SLIT	
6	2-113-137-01	BUSHING		24	X-2113-102-1	SLIDER (RIGHT) ASSY	
7	X-4941-333-1	HOUSING (LEFT) ASSY		25	X-2113-115-1	CASE (RIGHT) ASSY, CLICK	
8	X-4941-334-1	HOUSING (RIGHT) ASSY		* 26	2-113-125-11	LID (RIGHT), CLICK CASE	
9	2-113-133-11	HANGER (RIGHT)		27	2-113-131-11	LID (RIGHT), HANGER	
10	2-113-132-11	HANGER (LEFT)		28	2-113-149-01	RING, URETHANE	
11	2-113-134-11	CASE, HINGE		29	1-580-792-21	CORD (WITH PLUG)	
12	7-671-113-01	STEEL, BALL 3		30	1-542-491-11	DRIVER (040F001P)	
13	2-113-146-01	SPRING, COMPRESSION		31	1-506-589-11	ADAPTOR, PLUG	
14	X-2113-116-1	CASE (LEFT) ASSY, CLICK		*****			
* 15	2-113-122-01	BAND, HEAD		ACCESSORIES			
16	X-2113-112-1	CUSHION ASSY, HEAD		*****			
* 17	2-113-124-11	LID (LEFT), CLICK CASE		2-113-147-11	CASE, SOFT		
18	X-2113-101-1	SLIDER (LEFT) ASSY					

MEMO



## Computer Audio Interface

# U-PHORIA UMC204/UMC202 UMC22/UM2

### UMC204

#### Audiophile 2x4 24-Bit/96 kHz USB Audio/MIDI Interfaces with MIDAS Mic Preamplifiers

- 2x4 USB2.0 Audio/MIDI Interface for recording microphones and instruments
- Audiophile 24-Bit/96 kHz resolution for professional audio quality
- Compatible with popular recording software including Avid Pro Tools\*, Ableton Live\*, Steinberg Cubase\*, etc.
- Streams 2 inputs / 4 outputs plus 1x MIDI I/O with ultra-low latency to your computer, supporting Mac OS X and Windows XP or higher
- 2 state-of-the-art, MIDAS designed Mic Preamplifiers with +48 V phantom power
- Analog Inserts for use of external effects such as compressors, etc.
- Zero-latency direct monitoring while recording
- Input/Playback Mix control and Stereo/Mono switch for direct monitoring
- Powerful Phones output with Level control and Monitor A/B source select for DJ-style cueing
- "Built-like-a-tank", impact-resistant metal chassis



### U-PHORIA USB Audio Interfaces

Audiophile high resolution  
USB Audio/MIDI Interfaces

When it's time to make recording history, you need the best audio interface you can get, and you need one you can count on. That's why we're kicking it up a notch with our new U-PHORIA Series USB Audio Interfaces. With 4 unique models to choose from, the U-PHORIA Series has the ideal interface to make your recording experience legendary.

### MIDAS-Design Preamps

Renowned for their mastery of digital console design, our sister company MIDAS developed the world-class preamps for the UMC204, UMC202 and UMC22 interfaces—and thanks to the available +48 V phantom power, you can even use professional-grade studio condenser mics to create outstanding tracks.

### 96 kHz Precision

You take your tracks seriously, and the U-PHORIA Series respects that, providing your choice of 96 kHz resolution (UMC204/UMC202), or 48 kHz resolution converters (UMC22/UM2), depending on your application. Both sampling rates offer better than CD recording quality for professional results.

### Convenient Monitoring

All U-PHORIA models provide powerful phones output with Level control and Direct Monitor select, Status, Signal and Clip LEDs, and are powered via your computer's USB port so they're ready to go wherever you go. Plus we provide free audio recording, editing and podcasting software, plus 150 instrument / effect plug-ins—just a download away at [behringer.com](http://behringer.com).



# U-PHORIA UMC204/UMC202 UMC22/UM2

## UMC202 Audiophile 2x2, 24-Bit/96 kHz USB Audio Interface with MIDAS Mic Preamplifiers

- 2x2 USB2.0 audio interface for recording microphones and instruments
- Audiophile 24-Bit/96 kHz resolution for professional audio quality
- Compatible with popular recording software including Avid Pro Tools\*, Ableton Live\*, Steinberg Cubase\*, etc.
- Streams 2 inputs / 2 outputs with ultra-low latency to your computer, supporting Mac OS X and Windows XP or higher
- 2 state-of-the-art, MIDAS designed Mic Preamplifiers with +48 V phantom power
- Zero-latency direct monitoring while recording
- Powerful Phones output with Level control and Direct Monitor select
- "Built-like-a-tank", impact-resistant metal chassis

## UMC22 Audiophile 2x2 USB Audio Interface with MIDAS Mic Preamplifier

- 2x2 USB audio interface for recording microphones and instruments
- Audiophile 48 kHz resolution for professional audio quality
- Compatible with popular recording software including Avid Pro Tools\*, Ableton Live\*, Steinberg Cubase\*, etc.
- Streams 2 inputs / 2 outputs with ultra-low latency to your computer, supporting Mac OS X and Windows XP or higher
- State-of-the-art, MIDAS designed Mic Preamplifier with +48 V phantom power

## Front Panel

### UMC204

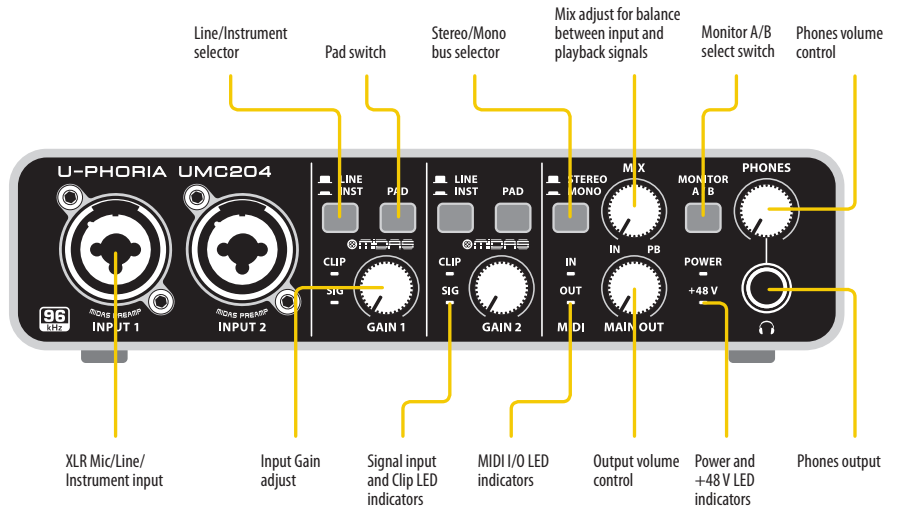

### UMC202

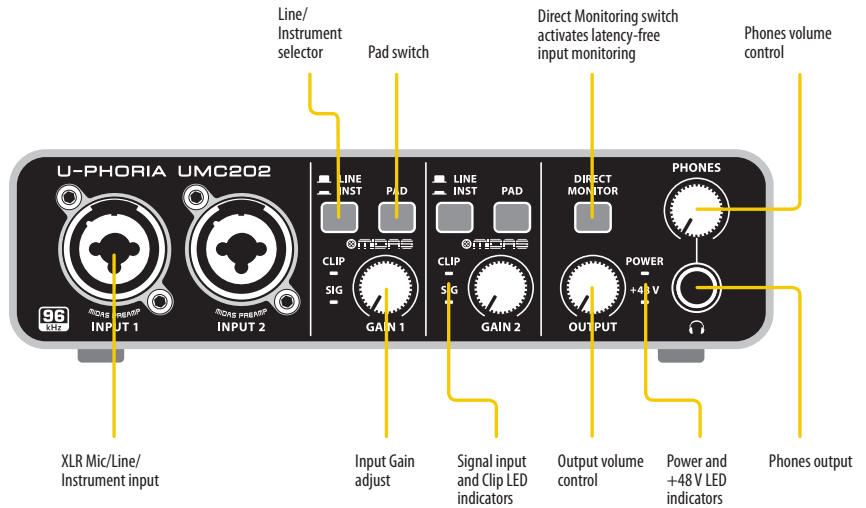

### UMC22

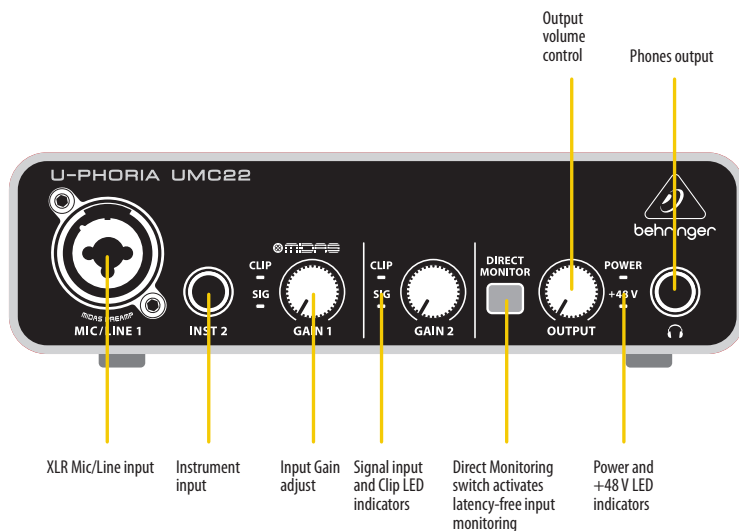

# U-PHORIA UMC204/UMC202 UMC22/UM2

- Powerful Phones output with Level control and Direct Monitor select
- “Built-like-a-tank”, impact-resistant metal chassis

## UM2 Audiophile 2x2 USB Audio Interface with XENYX Mic Preamplifier

- 2x2 USB audio interface for recording microphones and instruments
- Audiophile 48 kHz resolution for professional audio quality
- Compatible with popular recording software including Avid Pro Tools\*, Ableton Live\*, Steinberg Cubase\*, etc.
- Streams 2 inputs / 2 outputs with ultra-low latency to your computer, supporting Mac OS X and Windows XP or higher
- State-of-the-art, +48 V-powered XENYX Mic Preamp comparable to stand-alone boutique preamps
- Powerful Phones output with Level control and Direct Monitor select

### Common features

- Status, Signal and Clip indications for perfect overview
- USB port for connection and power
- Free audio recording, editing and podcasting software plus 150 instrument/effect plug-ins downloadable at [behringer.com](http://behringer.com)
- High-quality components and exceptionally rugged construction ensure long life
- Conceived and designed by BEHRINGER Germany

\* Windows is a registered trademark of Microsoft Corporation in the United States and other countries. Mac and OS X are trademarks of Apple Inc., registered in the U.S. and other countries. All trademarks, including, but not limited to Avid, Pro Tools, Ableton, Steinberg, and Cubase are trademarks or registered trademarks of their respective owners. Their use neither constitutes a claim of the trademark nor affiliation of the trademark owners with MUSIC Group.

## UM2

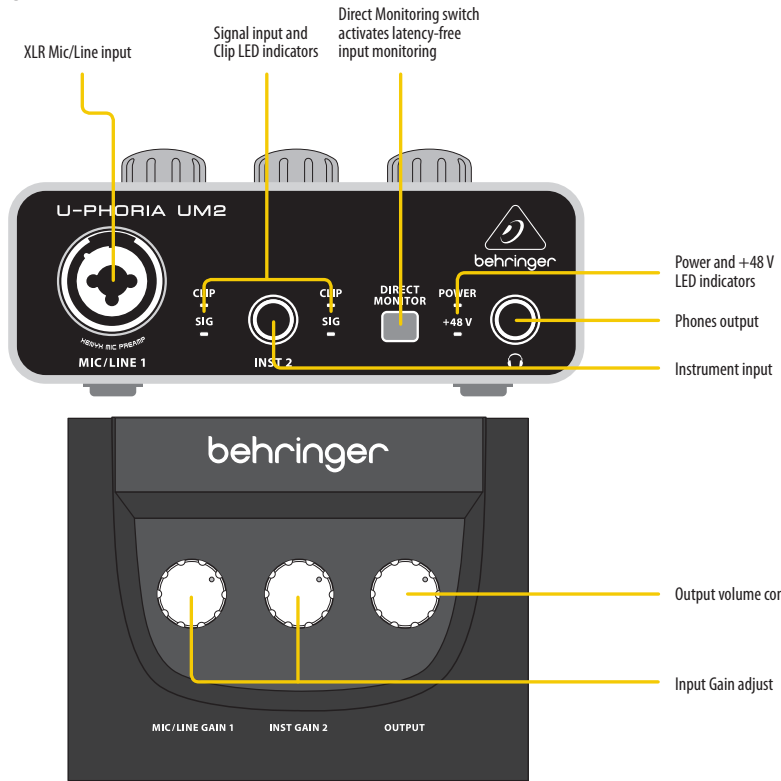

## Rear Panel

### UMC204

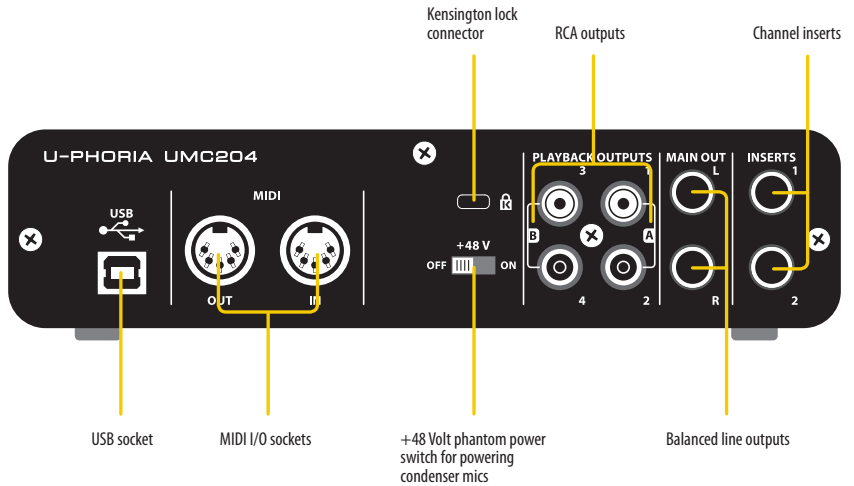

### UMC202

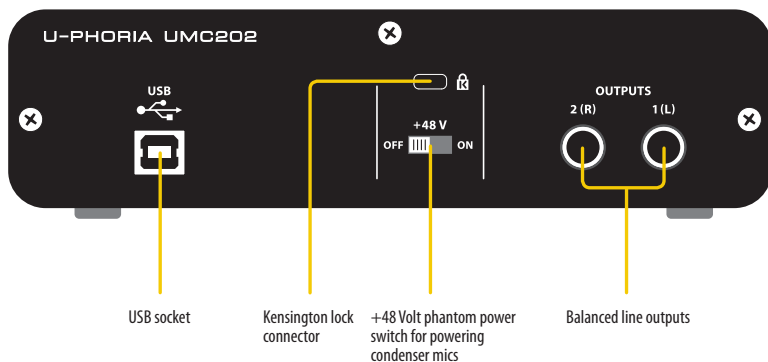

# U-PHORIA UMC204/UMC202 UMC22/UM2

## UMC22

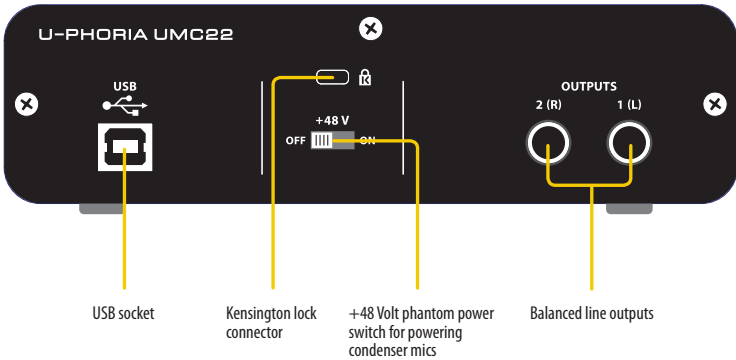

## UM2

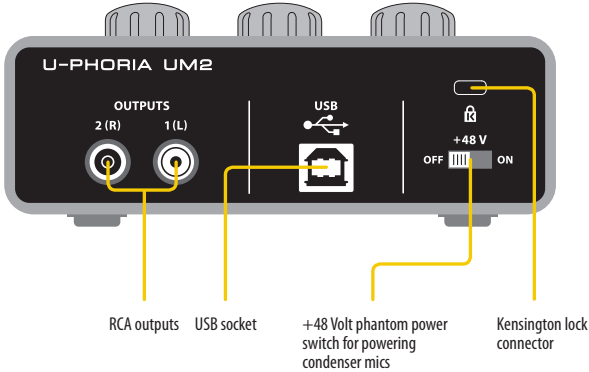

## Home/Project Recording Setup

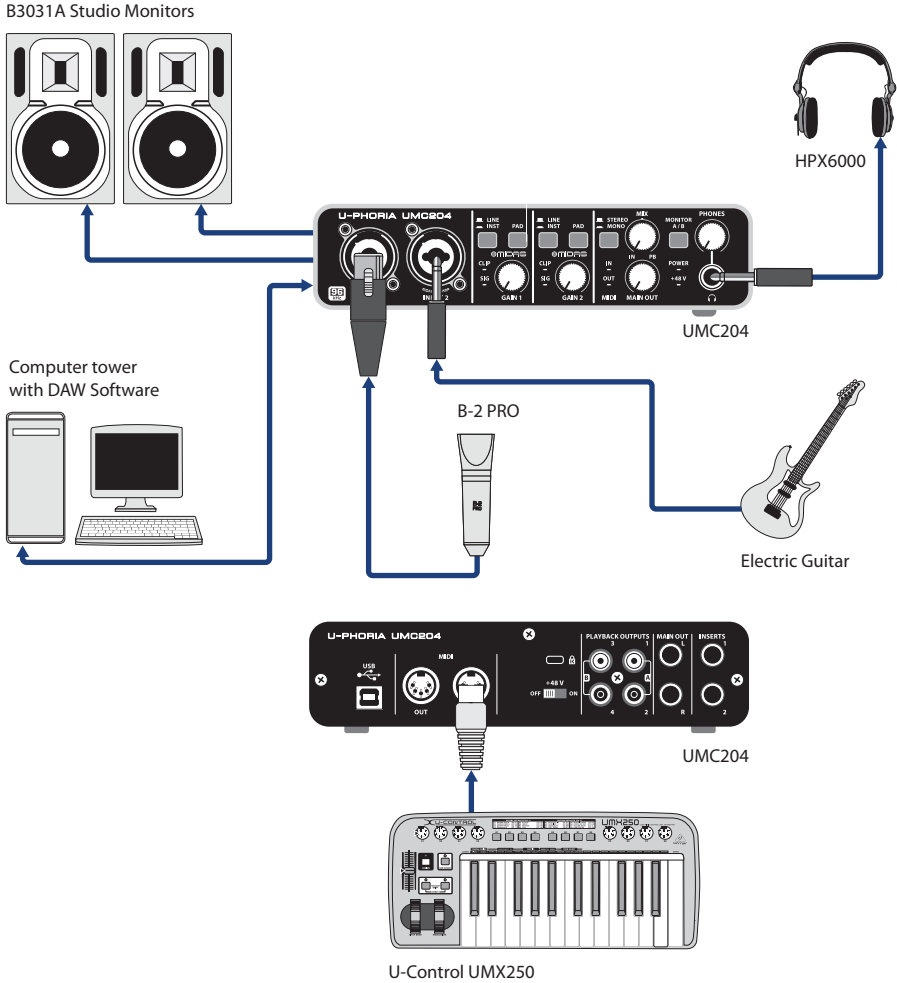

U-CONTROL UMX250 USB/MIDI controller connected to the MIDI input socket (UMC204 only)

# U-PHORIA

## UMC204/UMC202

## UMC22/UM2

### Feature Comparison Chart

Series	U-PHORIA			
	UMC204	UMC202	UMC22	UM2
Model	UMC204	UMC202	UMC22	UM2
Form Factor	Mini Rack	Mini Rack	Mini Rack	Mini Desktop
Interface	USB Audio/MIDI	USB Audio	USB Audio	USB Audio
OS Support	Mac OS X, Windows XP or higher	Mac OS X, Windows XP or higher	Mac OS X, Windows XP or higher	Mac OS X, Windows XP or higher
Ultra-low latency support	Core Audio, ASIO	Core Audio, ASIO	Core Audio, ASIO	Core Audio, ASIO
USB Audio	2x4 In/Out	2x2 In/Out	2x2 In/Out	2x2 In/Out
Max. Sampling Rate	96 kHz	96 kHz	48 kHz	48 kHz
USB MIDI	1x1 I/O	—	—	—
Mic Preamps	2 x MIDAS	2 x MIDAS	1 x MIDAS	1 x XENYX
Phantom Power	+48 V	+48 V	+48 V	+48 V
Inputs	2x Mic/Line/Instr (XLR Combo)	2x Mic/Line/Instr (XLR Combo)	1x Mic/Line (XLR Combo), 1 x Instrument (¼" jack)	1x Mic/Line (XLR Combo), 1 x Instrument (¼" jack)
Outputs	2x ¼" TRS jack, 4 x RCA, 1 x Phones	2x ¼" TRS jack, 1 x Phones	2x ¼" TRS jack, 1 x Phones	2x RCA, 1 x Phones
Analog Input Inserts	2x	—	—	—
Zero-Latency Direct Monitoring	Yes	Yes	Yes	Yes
Input/Playback Mix Control	Yes	—	—	—
DJ-Style A/B Monitor Select	Yes	—	—	—
USB bus-powering	Yes	Yes	Yes	Yes
Kensington Lock	Yes	Yes	Yes	Yes
Free Software (Audio Recording, Editing, Podcasting, 150 instrument / effect plug-ins)	downloadable @ behringer.com	downloadable @ behringer.com	downloadable @ behringer.com	downloadable @ behringer.com

For service, support or more information contact the BEHRINGER location nearest you:

**Europe**  
**MUSIC Group Services UK**  
 Tel: +44 156 273 2290  
 Email: CARE@music-group.com

**USA/Canada**  
**MUSIC Group Services NV Inc.**  
 Tel: +1 702 800 8290  
 Email: CARE@music-group.com

**Japan**  
**MUSIC Group Services JP K.K.**  
 Tel.: +81 3 6231 0454  
 Email: CARE@music-group.com

This device has not been authorized by the rules of the Federal Communications Commission. This device is not, and may not be, offered for sale or lease, or sold or leased in the 50 U.S. states, the District of Columbia and U.S. possessions, until authorization is obtained. Technical specifications and appearances are subject to change without notice and accuracy is not guaranteed. BEHRINGER, KLARK TEKNIK, MIDAS, BUGERA, and TURBOSOUND are part of the MUSIC Group (music-group.com). Windows is a registered trademark of Microsoft Corporation in the United States and other countries. Mac and OS X are trademarks of Apple Inc., registered in the U.S. and other countries. All trademarks, including, but not limited to Avid, Pro Tools, Ableton, Steinberg, and Cubase are trademarks or registered trademarks of their respective owners. Their use neither constitutes a claim of the trademarks nor affiliation of the trademark owners with MUSIC Group. MUSIC Group accepts no liability for any loss which may be suffered by any person who relies either wholly or in part upon any description, photograph or statement contained herein. Colors and specifications may vary from actual product. MUSIC Group products are sold through authorized fulfillers and resellers only. Fulfillers and resellers are not agents of MUSIC Group and have absolutely no authority to bind MUSIC Group by any express or implied undertaking or representation. This manual is copyrighted. No part of this manual may be reproduced or transmitted in any form or by any means, electronic or mechanical, including photocopying and recording of any kind, for any purpose, without the express written permission of MUSIC Group IP Ltd. ALL RIGHTS RESERVED © 2013 MUSIC Group IP Ltd. Trident Chambers, Wickhams Cay, P.O. Box 146, Road Town, Tortola, British Virgin Islands.

behringer.com

