

MKS SKIPR User Manual

This document is the basic hardware and firmware description of MKS SKIPR, which is convenient for beginners or users who are not familiar with 3D printing.

If your question is deeper, or the documentation doesn't mention it.

*Please don't worry, you can contact us through **Amazon** information or email (makerbase123@126.com), we will try our best to help you solve the problem.*

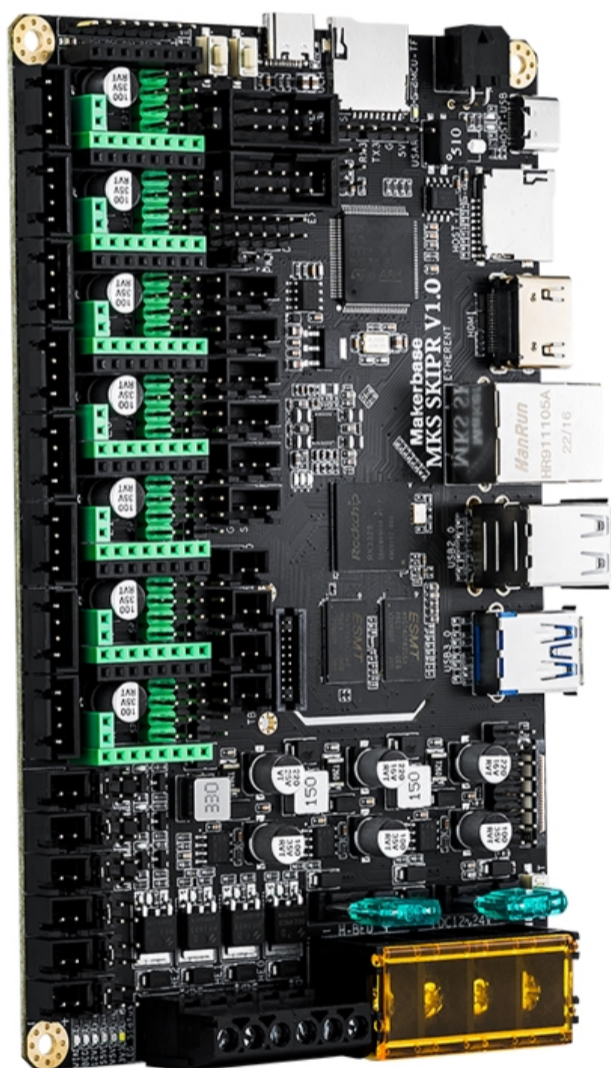

This document is divided into 3 parts

MKS SKIPR Hardware Interface

MKS SKIPR Operation Process

Q&A of MKS MKS SKIPR

MKS SKIPR Hardware Interface

Wiring :

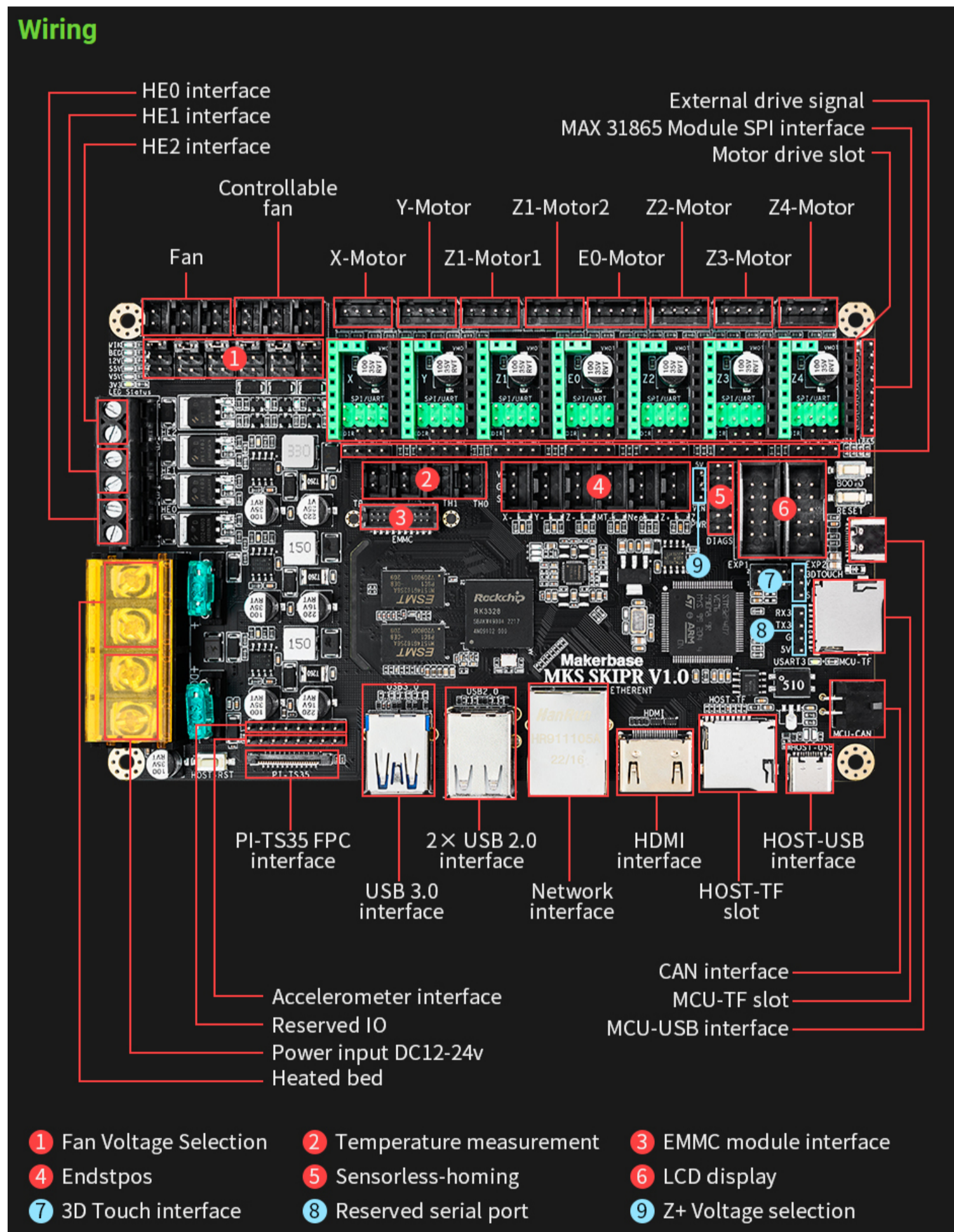

Size

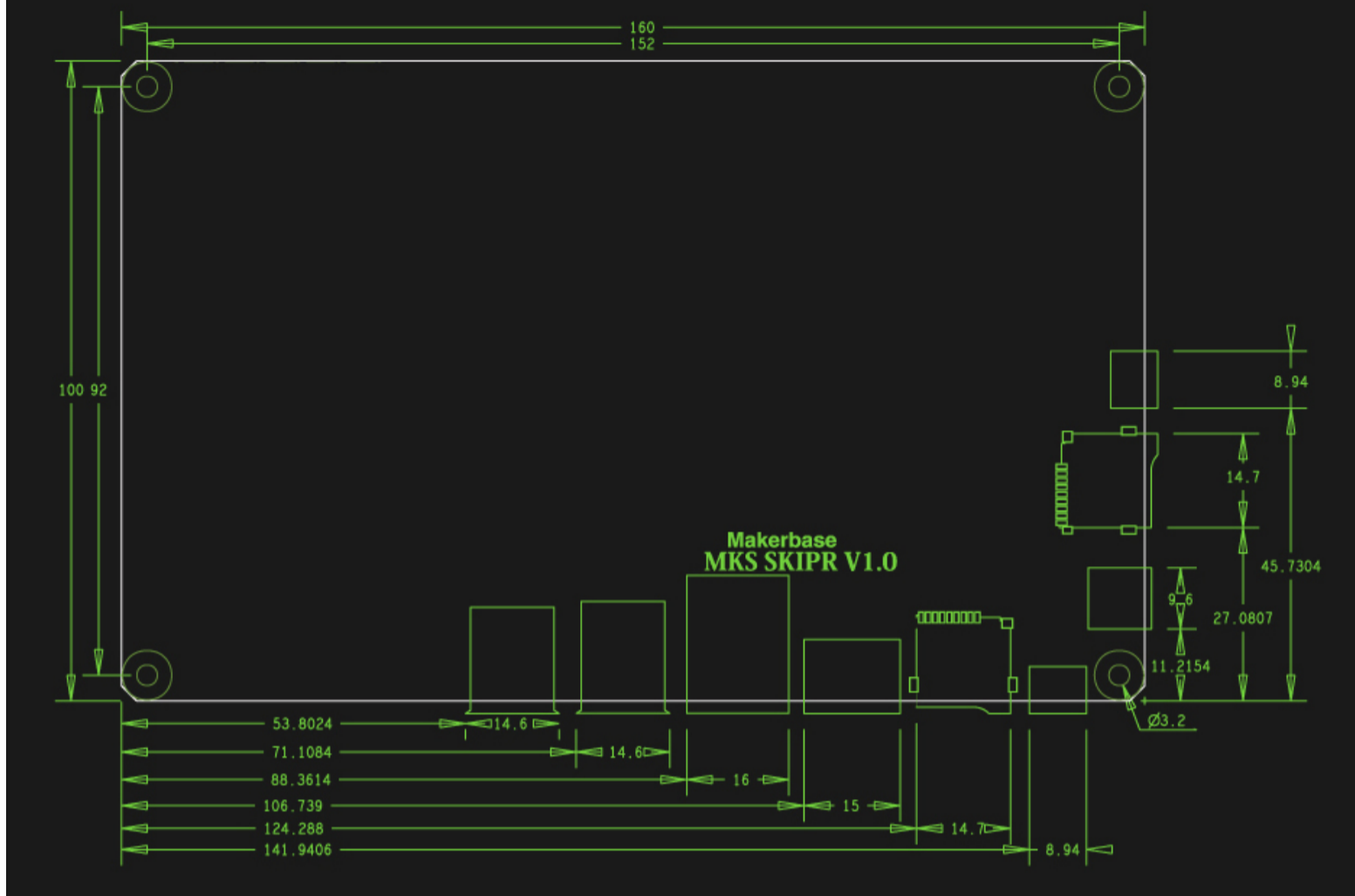

After you receive the motherboard, first check whether the appearance of the motherboard is complete. Then you can connect according to the interface marked in the picture according to the wiring of your printer.

Note:

1. During the connection process, you need to pay attention to the power supply, hotbed, hotend, fan and other interfaces, all of which have a distinction between "+" and "-", so you must pay attention to the wiring process to prevent the positive and negative connections from being reversed, resulting in damage to the motherboard.

2. MKS SKIPR needs to be connected to the sd card(To HOST SD SLOT) or EMMC module that has updated the MKS image file. After the connection is completed, it will be powered on to start normally. If there is no sd card or emmc with image file connected, MKS SKIPR cannot run

3. Any wiring or adjustment operation, please do it when the power is off.

4. The operation of MKS SKIPR module needs to provide 12-24v power supply, and it is not recommended to use 5v for power supply. (Because of the usb-5v power supply, the power is too low to load the operation of the module).

If you need information such as the schematic diagram of MKS SKIPR, you can download it from this website :

https://github.com/makerbase-mks/MKS-SKIPR/tree/main/hardware/MKS%20SKIPR%20V1.0_002

MKS SKIPR Operation Process

Image file download

Image file download link:

<https://drive.google.com/drive/folders/1tTuSvF9OL2qtPXElau8YOXn2sWbdxa9e?usp=sharing>

The latest version of the file can be downloaded from this link

Image file update

You can update the image file to the **SD card** through the corresponding software, or the **EMMC** module included in the package. (The emmc module has already updated the image file by default and can be used directly. If you need to update the new version of the image file, you can also refer to this operation)

Hardware Preparation

- A TF memory card not less than 8G
- TF card reader
- PC with windows operating system installed
- Wireless network card or network cable
- Type_C cable

Software preparation

System image download link:

<https://drive.google.com/drive/folders/1tTuSvF9OL2qtPXElau8YOXn2sWbdxa9e?usp=sharing>

Install balenaEtcher v1.5 and above, download link:

<https://www.balena.io/etcher/>

Install putty, download link:

<https://www.chiark.greenend.org.uk/~sgtatham/putty/latest.html>

The operation process can refer to this link :

<https://github.com/makerbase-mks/MKS-SKIPR#software-preparation>

After the image file is updated, connect the corresponding sd card(**To the host slot**) or emmc module to the MKS SKIPR, and then provide 12-24v power supply. MKS skipr will read the image file and enter the system, and the general boot time needs to wait for 40-50s. It is not recommended to cut off the power while waiting.

NOTE:The sd card or emmc module that has updated the image file must **always be connected to the skipr motherboard**. It is not a one-time update, and the image file needs to be read every time the system starts. If you don't connect or unplug midway, the system shuts down or crashes.

Klipper firmware update

The klipper firmware of MKS SKIPR can be downloaded directly to our github website (mks_skipr.bin)

<https://github.com/makerbase-mks/MKS-SKIPR/tree/main/klipper%20firmware>

Copy the downloaded file (mks_skipr.bin) to the gen root directory of another sd card (not the sd card of the image file).

Connect the sd card with the bin file installed to the **MCU-TF card slot** on the motherboard. Then the motherboard will automatically update after power on.

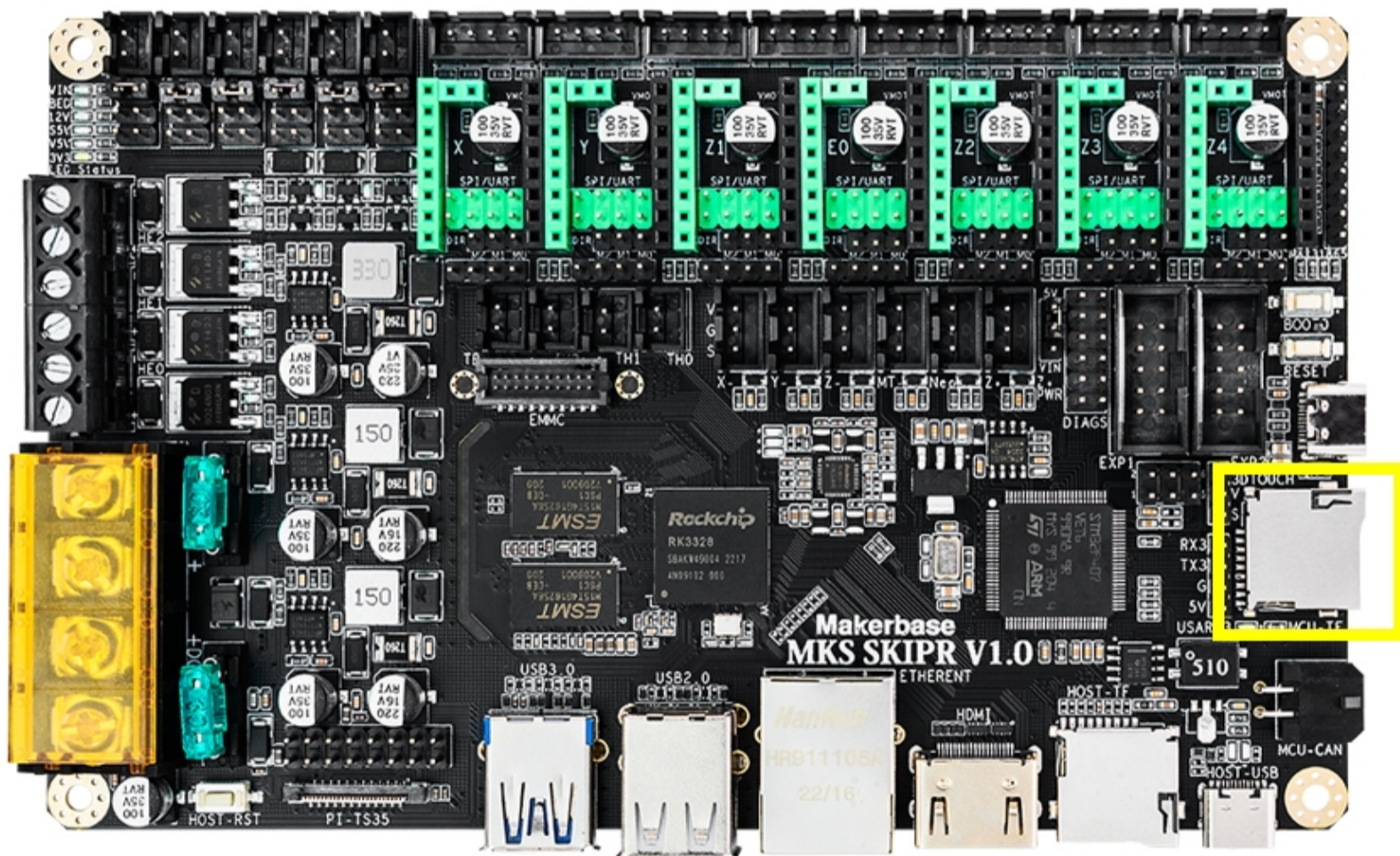
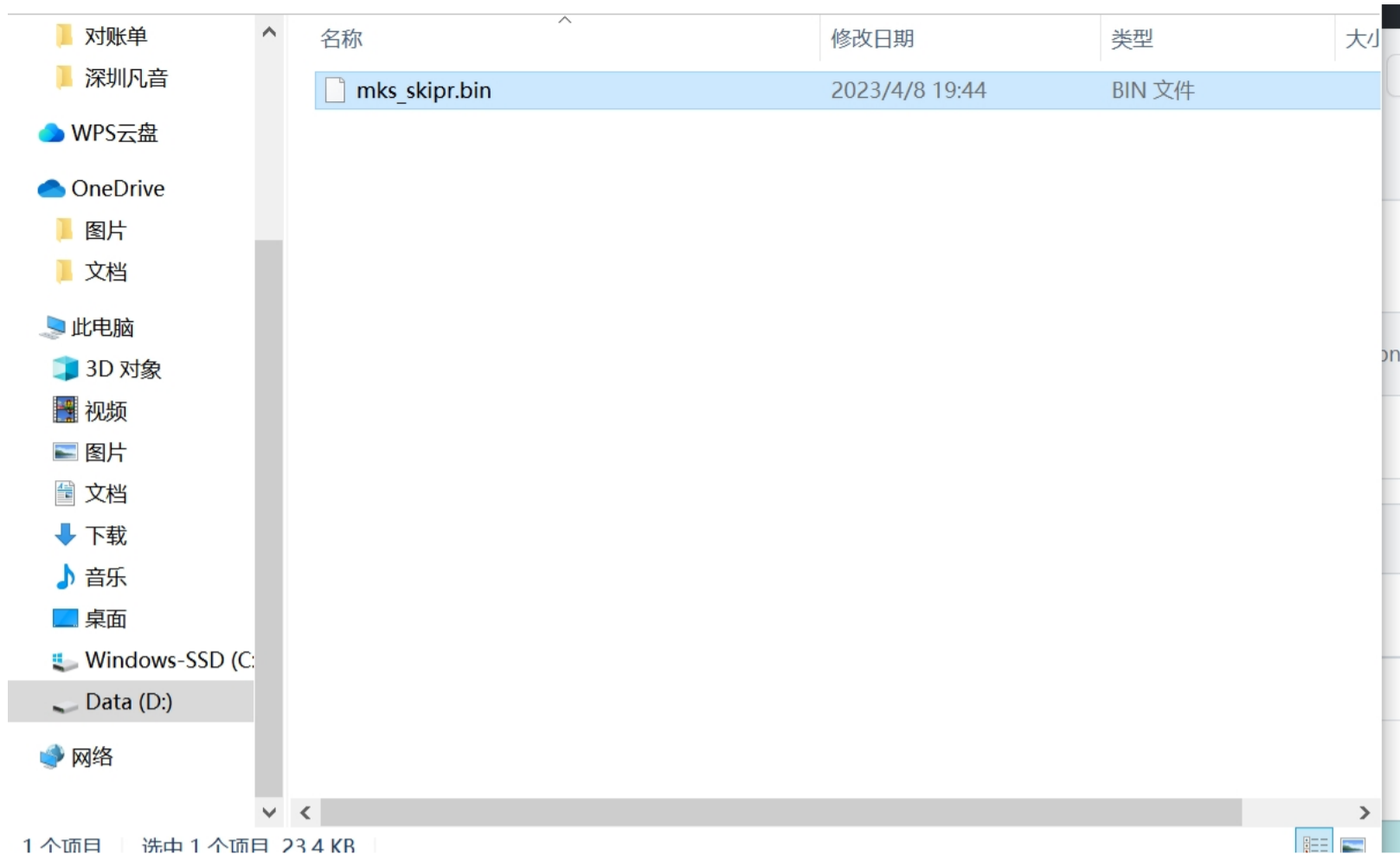

After the update is complete, the bin file will become a cur file. Indicates that the update was successful.

名称	修改日期	类型	大小
mks_skipr.CUR	2023/4/8 19:44	光标	

MKS SKIPR network connection

MKS SKIPR network connection has 2 ways: Ethernet and USB WiFi Adapter

Ethernet : Just set your router to using DHCP, plug the network cable into the MKS SKIPR, done.

USB WiFi Adapter: Connect the usb wifi network card to MKS SKIPR, and then set up the corresponding router in the system

Please refer to this link for the USB WiFi Adapter setup process:

<https://github.com/makerbase-mks/MKS-PI#using-usb-wifi-adapter>

*There is a simple method, you can directly connect the SD card or emmc module with the mirror file system to the PC, find this file in the root directory(**wpa supplicant-wlan0.conf**), modify the name and password of your own network in the file, and save the SD card Or emmc reconnects back to the skipr board. At the next startup, it will automatically connect to the network you set.*

名称	修改日期	类型	大小
dtb	2022/6/25 10:55	文件夹	
dtb-5.16.20-rockchip64	2022/6/25 10:55	文件夹	
extlinux	2022/6/25 10:54	文件夹	
.next	2022/6/25 10:55	NEXT 文件	0 KB
armbian_first_run.txt.template	2022/6/25 10:57	TEMPLATE 文件	2 KB
boot.bmp	2022/6/25 10:57	BMP 文件	38 KB
config-5.16.20-rockchip64	2022/6/25 10:45	20-ROCKCHIP64...	227 KB
F5CK0000.REC		REC 文件	4 KB
F5CK0001.REC		REC 文件	4 KB
Image	2022/6/25 10:45	文件	29,617 KB
initrd.img-5.16.20-rockchip64	2022/6/25 11:00	20-ROCKCHIP64...	12,292 KB
System.map-5.16.20-rockchip64	2022/6/25 10:45	20-ROCKCHIP64...	6,184 KB
ulnitrd	2022/6/25 11:00	文件	12,292 KB
vmlinuz-5.16.20-rockchip64	2022/6/25 10:45	20-ROCKCHIP64...	29,617 KB
wpa_supplicant-wlan0.conf	2022/6/28 9:42		

CSDN@Makerbase_mks

Action	Proar...	File
wpa_supplicant-wlan0.conf		
1	country=GB	
2	ctrl_interface=DIR=/var/run/wpa_supplicant GROUP=netdev	
3	update_config=1	
4		
5	network={	
6	ssid="MAKERBASE3D_Wi-Fi5"	
7	psk="12345678"	
8	key_mgmt=WPA-PSK	
9	}	
10		

*Note: During the process, you need to update the sd card or emmc module that already has an image file, and connect it to the PC through the sd card reader to modify the parameters. It is recommended to use the SD card reader with **USB3.0** protocol to connect, because the emmc module is a high-speed storage module, if you use usb2.0 or a card reader with a low reading rate, the PC may not be able to recognize it .*

MKS SKIPR control interface

There are two types of control pages for MKS SKIPR:

Touch screen control and web control

Touch screen control: connect the **MKS PI-TS35** screen to the MKS SKIPR, when the system starts, the screen will display the corresponding control page.

<https://www.youtube.com/watch?v=0aAxuZX9t6A>



Web page control: When MKS SKIPR is connected to a router, the corresponding IP can be displayed on the screen (if there is no router, you can query the corresponding IP in the router). Then you can enter the corresponding IP in the browser on the PC on the same router network to enter the **FLUIDD** control interface to control

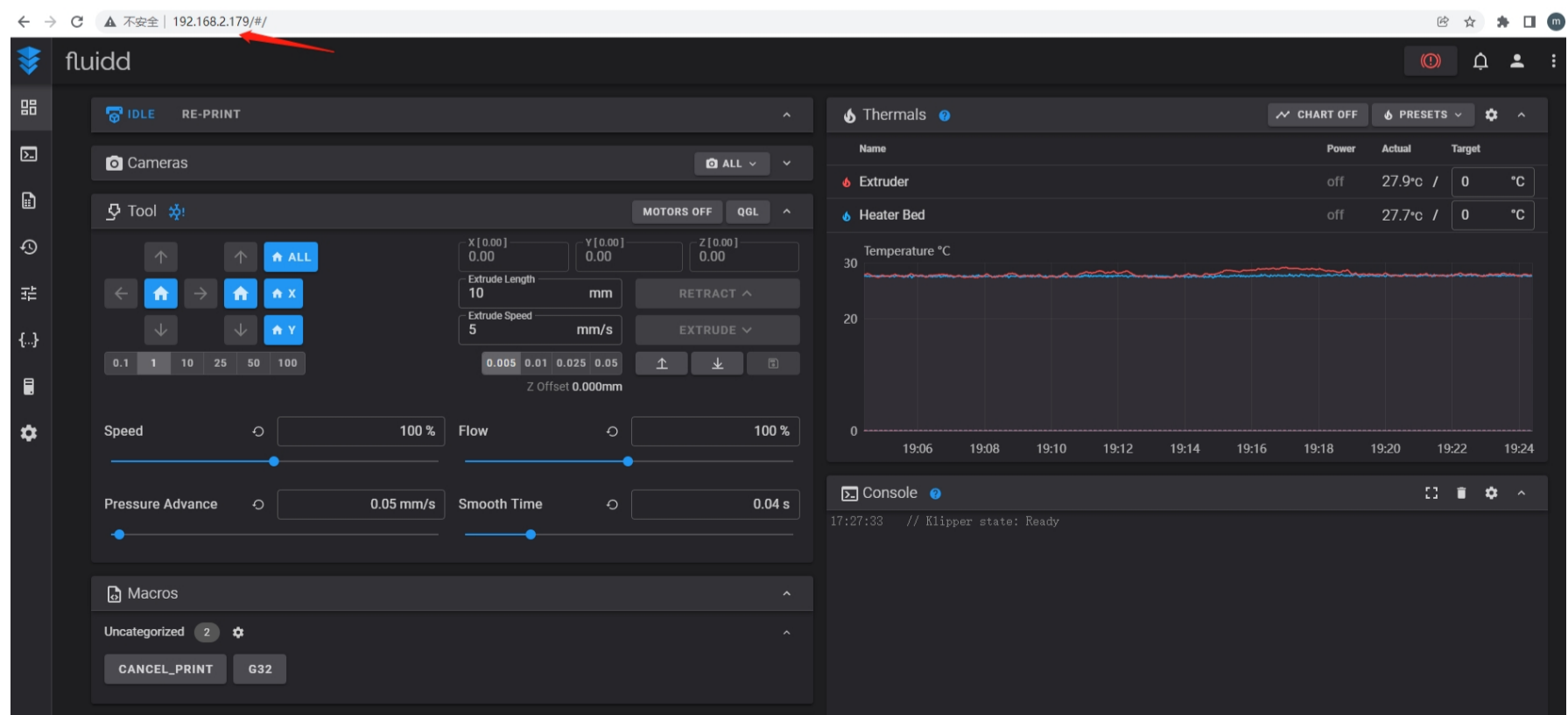

Printer parameter setting

You can go to the website to download the template of our skipr motherboard configuration file (the default is voron parameters), and then modify it according to your own printer parameters. After the modification is complete, rename the file to "printer.cfg", upload and replace the default cfg file in the fluidd web interface

<https://github.com/makerbase-mks/MKS-SKIPR/tree/main/klipper%20firmware>

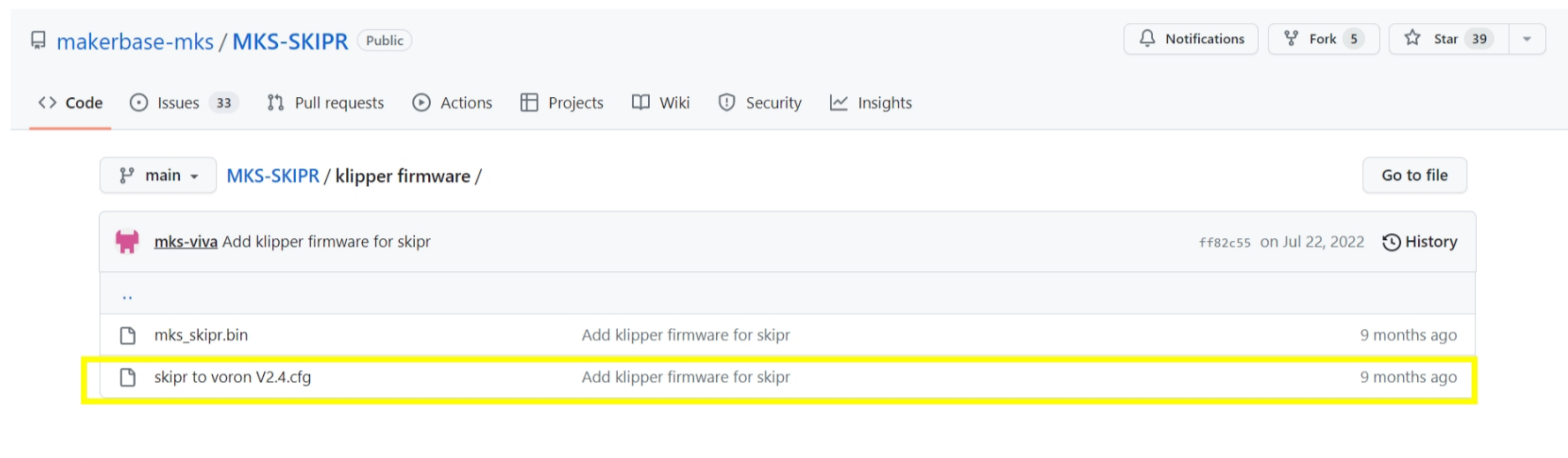

If after uploading the cfg, if you log in to the fluidd page again and there will be such a red error report, it means that the parameters in your cfg are wrong and need to be modified. You can modify it according to its prompt and save it again.

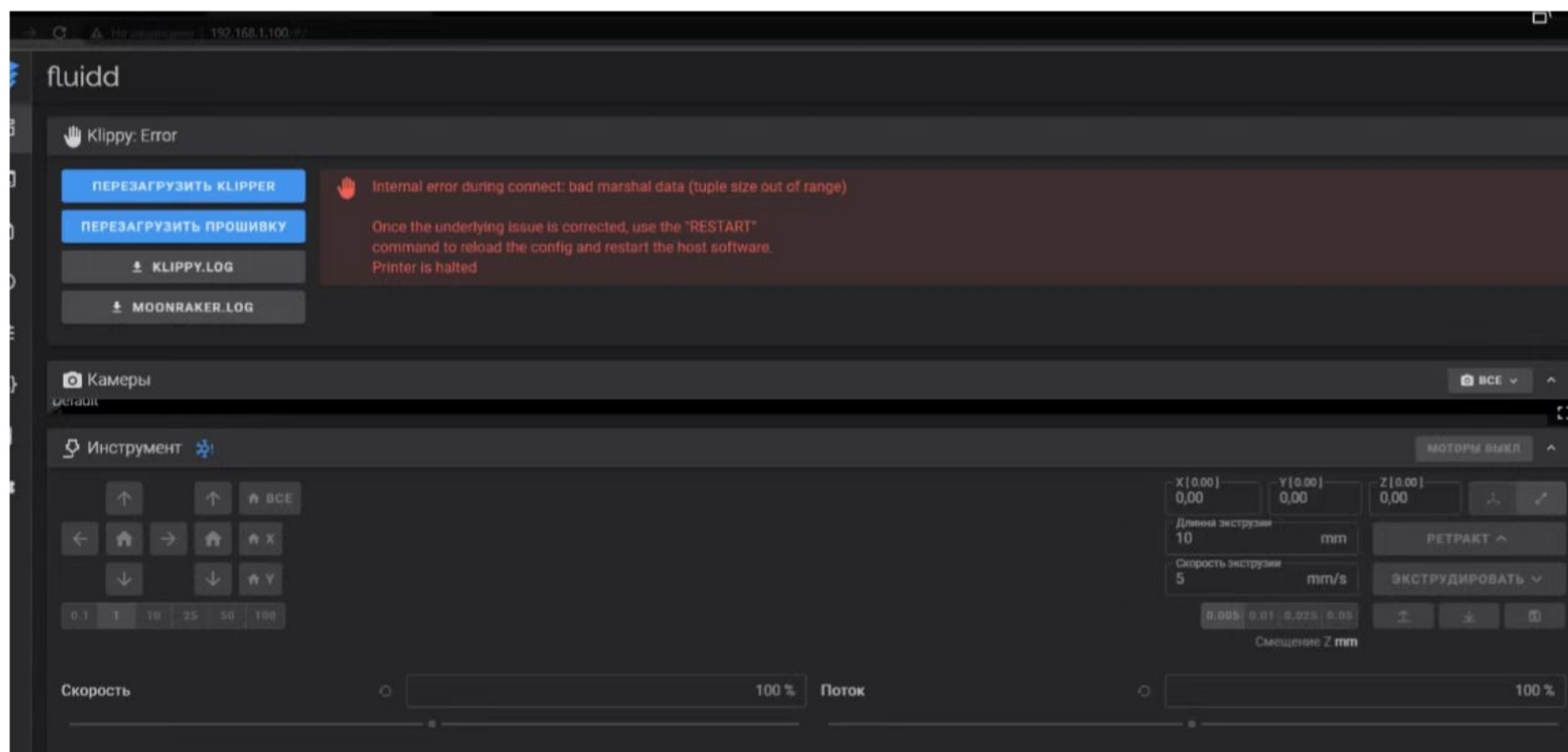

Printer klipper parameter configuration can refer to the official instructions

http://www.klipper3d.org/Config_Reference.html

Q&A of MKS SKIPR

Q1: Why the MKS SKIPR is connected to the MKS PI-TS35 screen is not bright.

A1 : 1. Check whether the MKS SKIPR is connected to the SD card or emmc module with the image file.

2. Check whether the MKS SKIPR has 12-24v power supply (if only 5v power supply may not be able to drive the screen normally)

3. Check whether the connection direction of the connection line of the screen MKS PI-TS35 is correct.

Q2: Why is the USB wireless network module connected, but the screen does not display the IP?

A2 : 1. MKS SKIPR still has the factory default network and password, so the connection is not successful. Follow the above procedure again to set up the wifi connection.

2. Check the stability of the network, and try to keep the module at an appropriate distance from the router.

Q3: Why does the screen or fluid report an error after the MKS SKIPR is connected to the 3D printed motherboard?

A3: It may be because the corresponding klipper firmware has not been updated for the 3D printed main board, or the parameters set by cfg conflict, you can consult the corresponding 3D printed main board manufacturer to obtain the corresponding file for updating. If it is an error in the parameter part, you can refer to the official document description of klipper for corresponding modification. (<http://www.klipper3d.org/>)

Q4: Why after restarting, the printer parameters are abnormal and cannot run normally

A4: Because you did not shut down the klipper firmware on the screen or fluid in advance after power off, and then power off. Some parameters of the cfg of the

klipper firmware are lost, so the printing is abnormal. The correct operation is to shut down the klipper firmware in advance (on the screen or web page), and then power off. If you have already performed the operation, you only need to re-upload a correct printer.cfg file, and you can resume normal work.

Q5:what if my question is not covered in this one?

A5:You can contact us directly through Amazon.

Or send questions to our email, or leave a message on our github

Email: makerbase123@126.com

Github: <https://github.com/makerbase-mks>

FACEBOOK:<https://www.facebook.com/Makerbase.mks/>