

hornbill

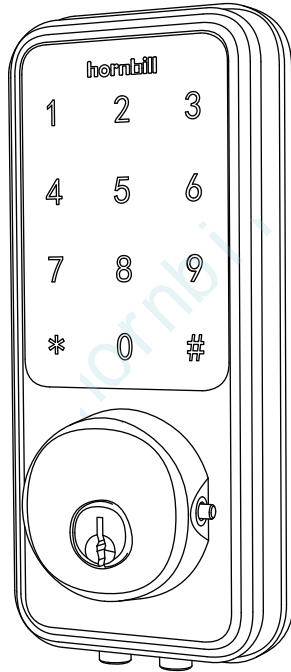

# USER MANUAL

Smart Lock with Keypad

HBUS-MD-BLK-KIT  
HBUS-MD-SIL-KIT  
G2.20210420

# CONTENTS

<b>1. What's Included</b>	01
<b>2. Product Overview</b>	02
<b>3. Specifications</b>	03
<b>4. Getting Started</b>	03
Download TTLock App	03
Prepare Door for Installation	04
<b>5. Installing the Smart Lock</b>	05
<b>6. Setting Up the Smart Lock</b>	11
Pair Your Phone with Smart Lock	11
Set Access Passcode	13
Send Ekey/Authorized Admin	14
Change/Delete Passcodes	14
Turn on Auto-Lock Feature	15
<b>7. Basic Operations</b>	15
Unlock the Door	15
Lock the Door	16
<b>8. Remote Control, Alexa/Google Home</b>	16
How to Pair with Your TTLock App	16
How to Remotely Unlock or Lock the Door	18
How to Use Alexa to Control the Door	18
How to Use Google Home to Control the Door	20
<b>9. Troubleshooting</b>	20
<b>10. Customer Service</b>	22
<b>11. How to Activate the Lock Warranty</b>	22
<b>12. Important Safety Instructions</b>	22

# 1. What's Included

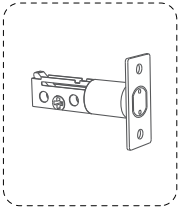

Deadbolt

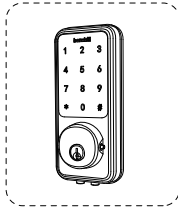

Front Panel

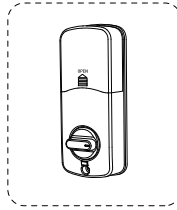

Back Panel

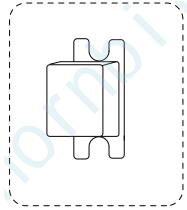

Deadbolt Cover

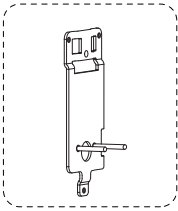

Mounting Plate

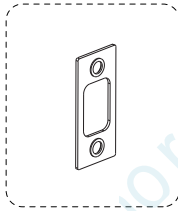

Strike Plate

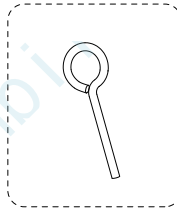

Pin

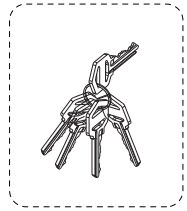

Keys

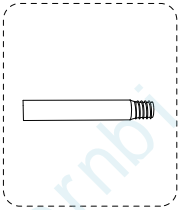

Front Panel  
Screw

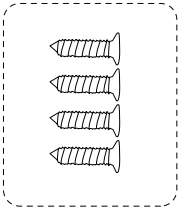

Strike Screws  
Deadbolt Screws

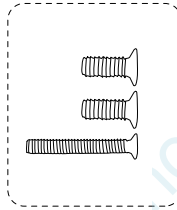

Back Panel  
Screws

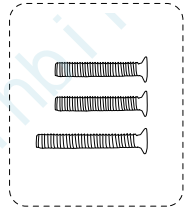

Mounting Plate  
Screws

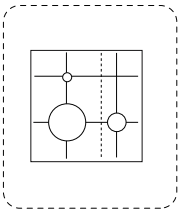

Mark Cards

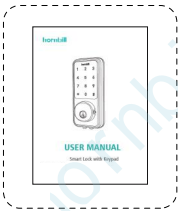

User Manual

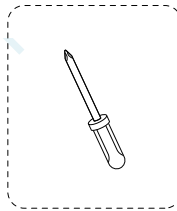

Phillips Screwdriver

## 2. Product Overview

### Front View

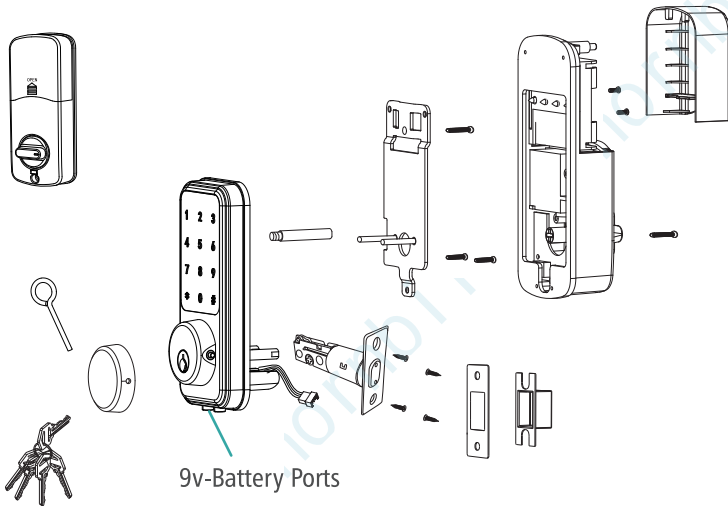

### Rear View

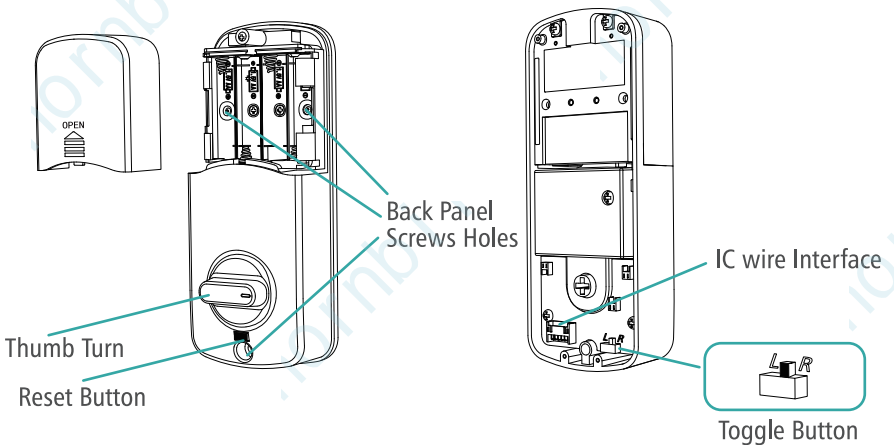

### 3. Specifications

Maximum Access Code: 150

Maximum Ekey: 1000+

Maximum Authorized Admin: 1000+

Communication Mode: Bluetooth 5.0

Waterproof: IP65 (Front Panel)

Numeric Keypad: Touchscreen Keypad

Operation Temp Range: -20℃ ~ 70℃ (-4°F ~ 158°F)

Lock Material: Zinc Alloy

Battery: 4×AA batteries (Not provided)

Battery Life: 6 Months (If Open and Close the Door for 10 Times Per Day)

Times to Unlock and Lock: 250,000 Times (Mechanical)

### 4. Getting Started

#### Download TTLock App

1. Download the TTLock App from the App Store (iOS devices running version 10.2 and later versions) or Google Play (Android devices running version 5.0 and later versions).
2. Set up for TTLock account: Use your phone number (add "+1" in the front of number) or your email to register an account.



# Prepare Door for Installation

1. Make sure that the following criteria are met so that the Smart Lock can be installed.

- ① Check the door status. Make sure the door frame is aligned with the door.
- ② There are no obstructions stuck in the door frame.
- ③ Leave enough space for the deadbolt to extend in to the door frame when the door is locked.

2. Check your door/frame dimensions to make sure that they fit the following measurements:

If you have an existing lock, remove it, including the bolt.

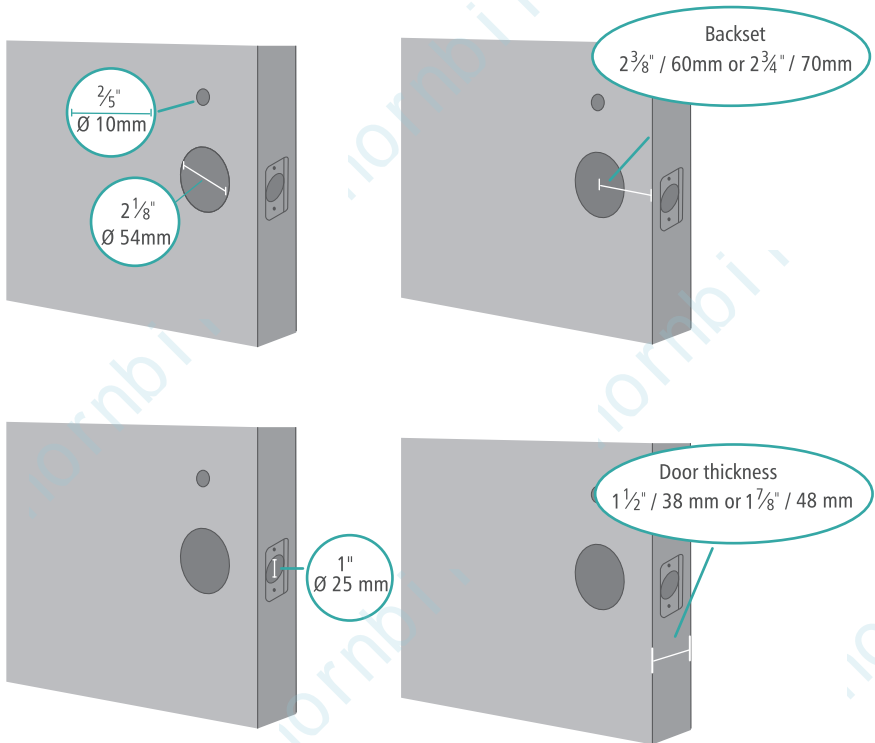

# 5. Installing the Smart Lock

## Step1: Install the Deadbolt

To install the deadbolt:

- ① Measure your door's backset dimension: whether it is 2 3/8"/60mm or 2 3/4"/70mm.
- ② If your door's backset dimensions 2 3/4"/70mm, turn the face plate 90° and pull to extend simultaneously until the deadbolt locks in position

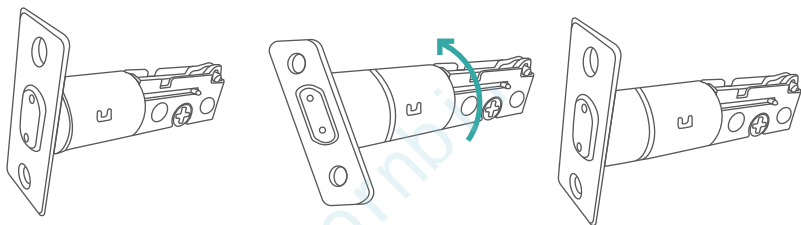

- ③ Insert the deadbolt into the door frame and make sure the word "UP" faces up as indicated on the deadbolt.
- ④ Screw into the door frame with a screwdriver.
- ⑤ What is required: Deadbolt, Deadbolt Screws, Screwdriver.

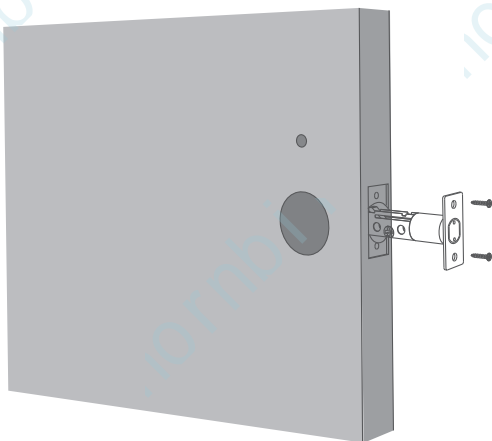

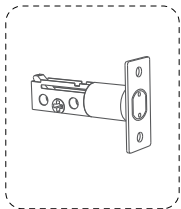

Deadbolt

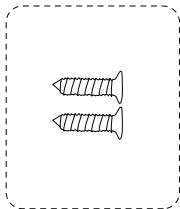

Deadbolt Screws

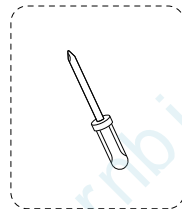

Phillips Screwdriver

## Step2: Install the Strike Plate

If you have an existing strike plate installed, skip this step.

To install the strike plate:

- ① Align the strike plate with the center hole of the deadbolt.
- ② Secure the strike plate with strike screws. Make sure the plate is placed in the correct direction.
- ③ What is required: Strike Plate, Strike Screws, Screwdriver.

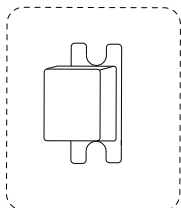
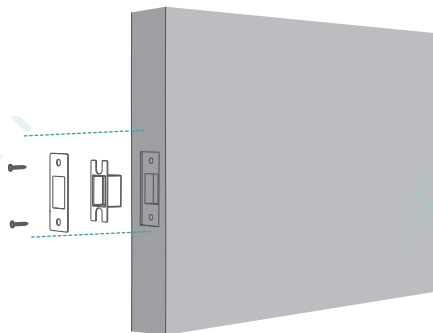

Deadbolt Cover

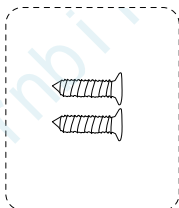

Strike Screws

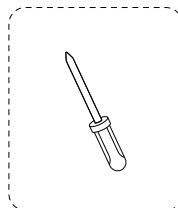

Phillips Screwdriver

### Step3: Install the Front Panel

To install the front panel into the door frame:

- ① Measure your cross bore dimension and determine the installation steps accordingly.
- ② Please use the provided the front panel screws to assist in installing the front panel.
- ③ Please make sure the flat ruler is horizontal status and the deadbolt is unlocked status when you install the lock.
- ④ Make sure the flat ruler insert the center hole of the deadbolt.
- ⑤ Route the IC wire connected on the front panel under the deadbolt.
- ⑥ What is required: Front Panel, Front Panel Screws.

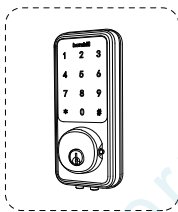
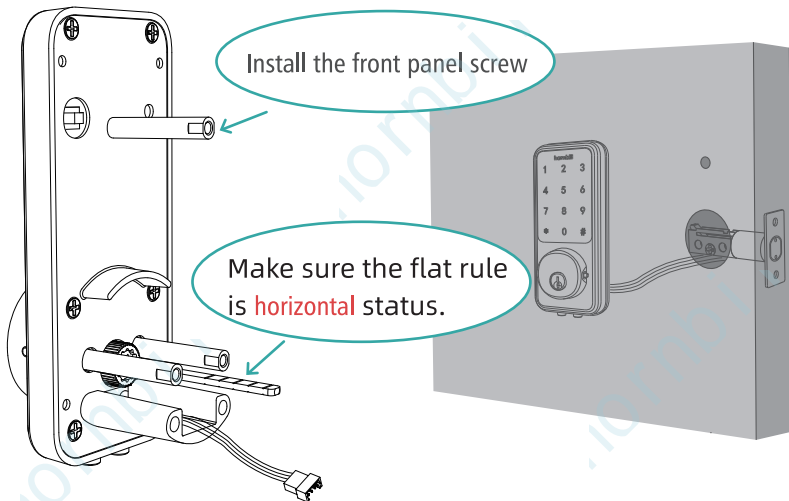

Front Panel

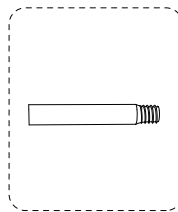

Front Panel  
Screws

## Step4: Install the Mounting Plate

1. Route the IC wire through the mounting plate.(Special hole)
2. Fix the mounting plate into the front panel using the mounting plate screws. Make sure the screws go through the holes of the deadbolt and the mounting plate, and lock into place.
3. What is required: Mounting Plate, Mounting Plate Screws

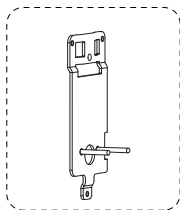
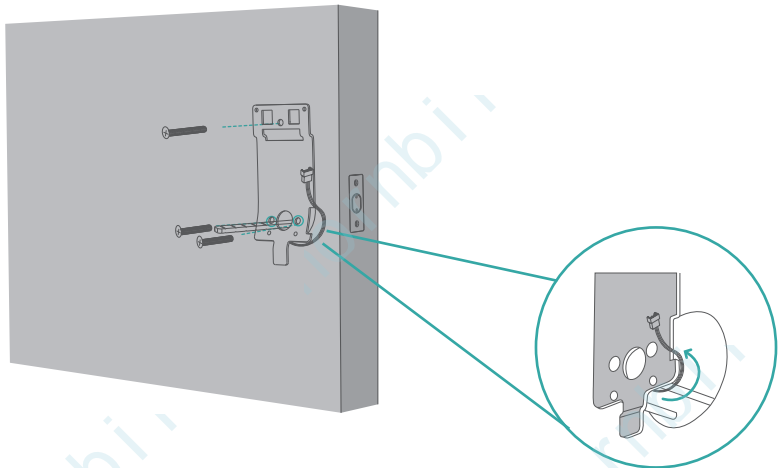

Mounting Plate

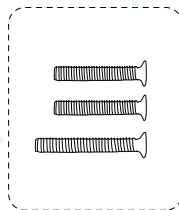

Mounting Plate  
Screws

## Step5: Install the Back Panel

### To install the Back Panel:

① Check/Adjust the Toggle Button( on the back panel bottom.)

A. If the hinges are in the left direction, adjust the toggle button to L, the thumb turn is horizontal status.

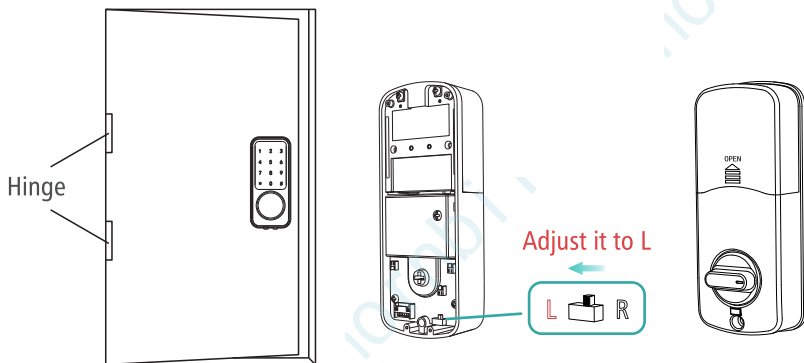

The hinges are on the Left side of the door

B. If the hinges are in the right direction, adjust the toggle button to R, the thumb turn is Vertical status.

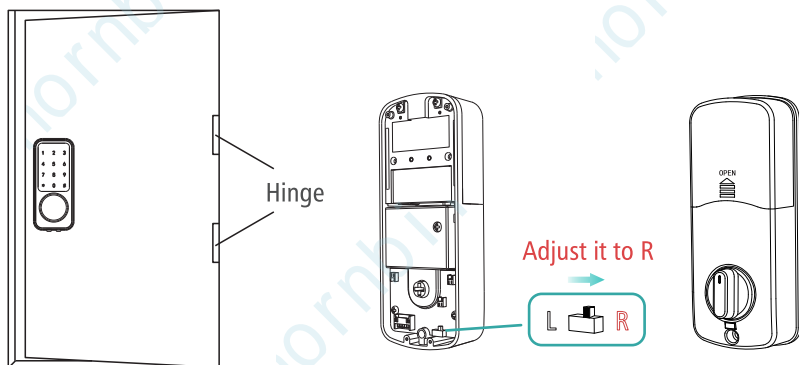

The hinges are on the Right side of the door

② Match the IC wire connector from the circuit board with the one from the back panel as illustrated. The wire connector can only be plugged into the socket in one way. Make sure you match the dot on the connector with the pin on the circuit board correctly.

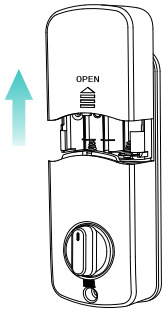

1

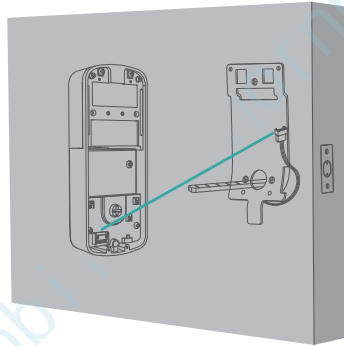

2

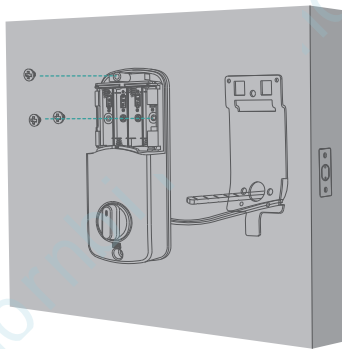

3

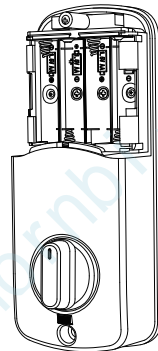

4

- ③ Align the flat rule with the key cylinder.
- ④ Secure the provided screws into the back panel.
- ⑤ Turn the thumb turn to check whether the deadbolt is retracted. If the deadbolt does not work smoothly, adjust the screws and install the mounting plate again.
- ⑥ What is required: Back Panel, Back Panel Screws, Screwdriver

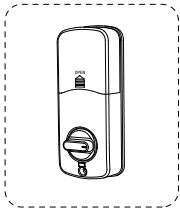

Back Panel

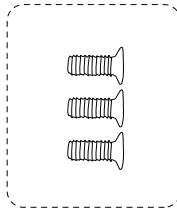

Back Panel  
Screws

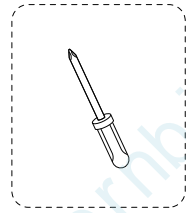

Phillips Screwdriver

## Step6: Install Batteries

---

Insert 4 AA batteries into the battery compartment matching the polarity(+/-) indicated.

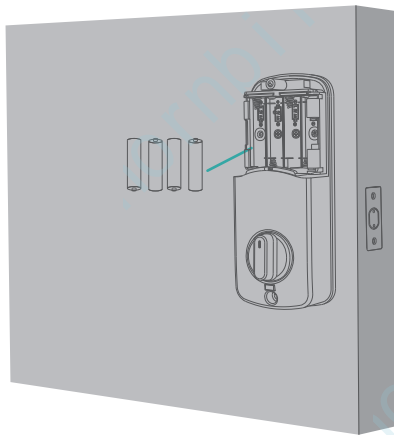

## 6. Setting up the Smart Lock

### Pair Your Phone with Smart Lock

---

To pair your phone with Smart Lock:

- ① Turn on Bluetooth, open the App, click Add Lock>Door Lock. Follow the on-screen instructions to complete the setup.

- ② Your phone will search for the smart lock, you need to touch the keypad any key.
- ③ After the lock is added, you will hear Di sound, the TTLock App will prompt you to name your Smart Lock.

**Note: The user that is paired is the only administrator, and can authorize other users to use the lock.**

**How to reset the smart lock? When the lock is added.**

Remove one battery, and put back the battery again. Press and hold the reset button 20 seconds (this black button under the knob), you will hear Di Di Sound, the lock will return to default settings. All the settings will be erased and need to be reset. DO NOT press and hold the button if unnecessary.

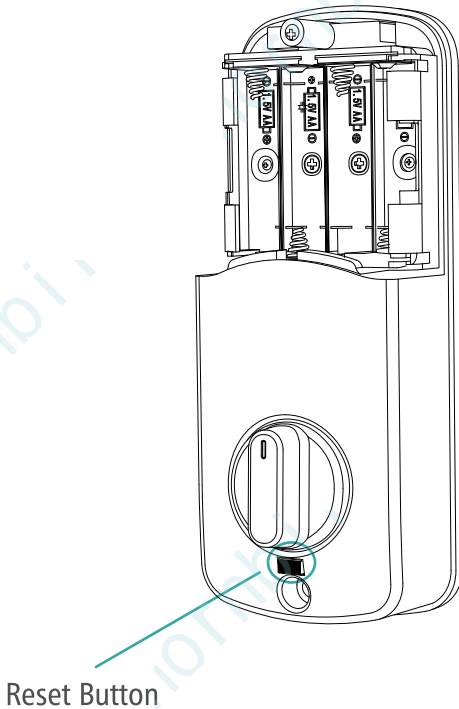

# Set Access Passcode

1. The owner passcode: You are the owner of the smart lock, so you can set your owner passcode. Click Settings>Basic>Admin Passcode. The admin passcode should be 4 to 9 characters.

2. Share the passcode with your guests and family members: Click Generate Passcode >Custom>give a name for the passcode>turn on permanent button>set the code you want, it should be 4 to 9 characters.

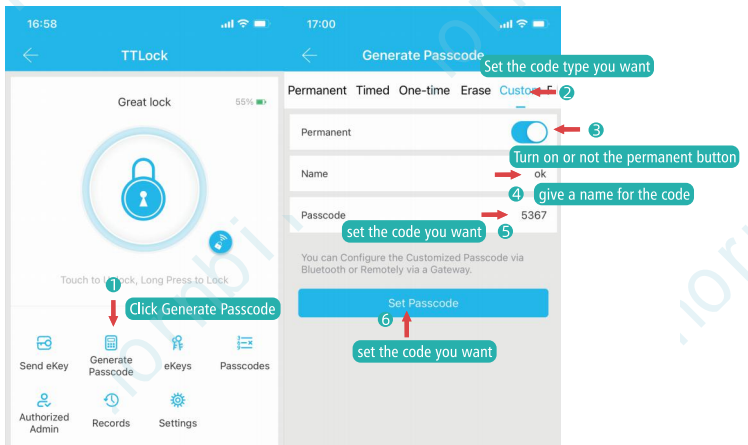
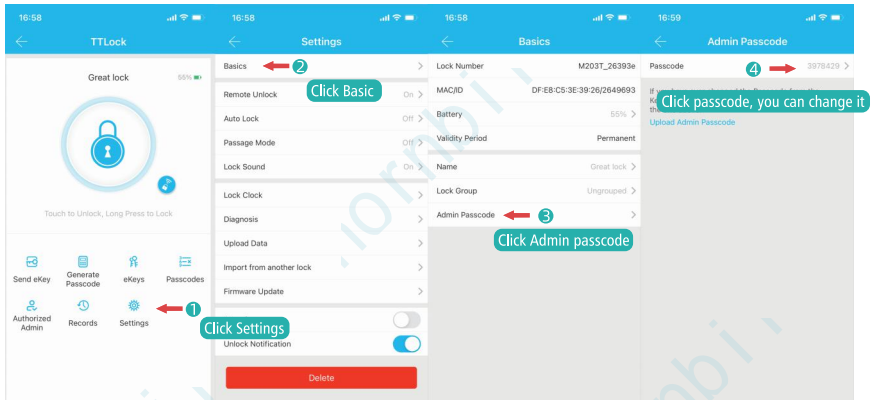

# Send Ekey/Authorized Admin

Note: If you hope your family member App controls the same lock, please make sure your family members have registered their own accounts.

1. Open your App, Click Send Ekey>Time/Permanent/One time/Recurring>Enter Recipient's account(If their account is phone number, enter 1 in the front of the number), turn on Allow Remote Unlocking button, click Send.
2. Let your family member to log out the App, and log in the App, they will find your lock in their App.

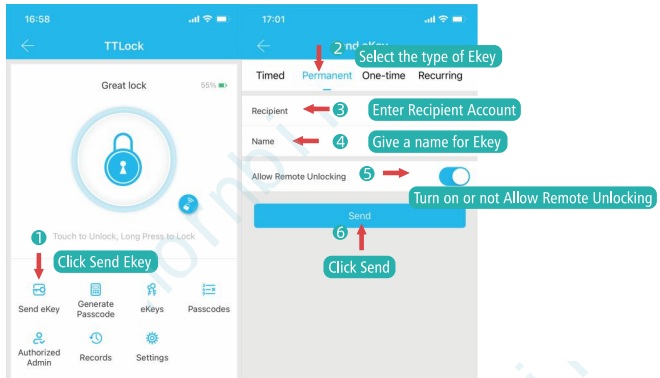

# Change/Delete Passcodes

Open your App, Click Passcodes>select the passcode name you want to modify>Click passcode>reset/change it. You can change the Validity Period or delete it.

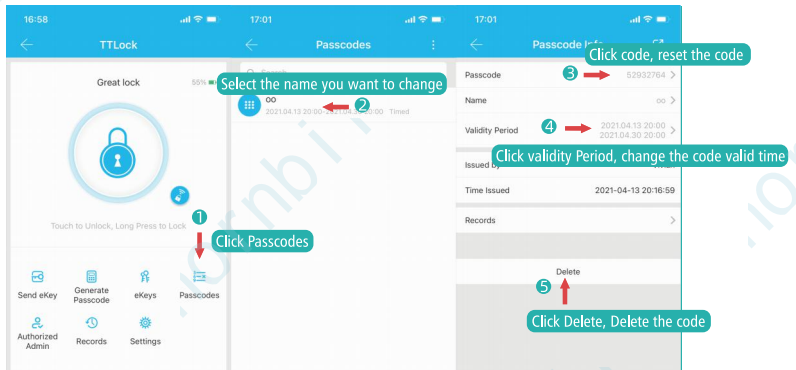

# Turn on Auto-Lock Feature

Click Settings>Auto Lock>turn on> you can setting the time, 5~900 seconds.

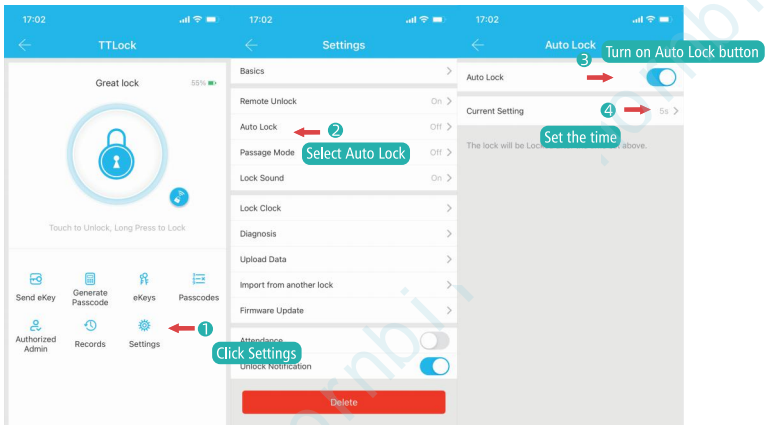

## 7. Basic Operations

### Unlock the Door

#### 1. Use the Passcode

Enter #passcode# on the keypad to unlock the door.

If the Passcode is correct, press #passcode#, the will unlock. If the passcode is wrong, press and enter a new passcode.

Paascode error: A beeps will be heard.

If you fail to unlock the door after 5 attempts using the passcode, the Smart Lock will be locked. The Keypad blinks blue for 3 seconds. Use the App instead to unlock.

#### 2. Use the TTLock App

Open the TTLock App. Touch the main button to unlock the door.

The App will search for Smart Lock Bluetooth and connect (Turn on Bluetooth)

#### 3. Use the Physical Key

Please use the pin to remove the key cover, then you can use the key to unlock the door.

## Lock the Door

---

### 1. One-Touch Lock the door

Hold down the # key for seconds on the keypad to lock the door.

### 2. Use the TLock App

Open the TLock App. Hold the main button to unlock the door.

The App will search for Smart Lock Bluetooth and connect(Turn on Bluetooth)

### 3. Set the Auto-Lock Feature

Click Settings>Auto Lock>turn on> you can setting the time, 5~900 seconds.

### 4. Use the Physical Key

Please use the pin to remove the key cover, then you can use the key to lock the door.

## 8. Remote Control, Alexa/Google Home

**Note:** Remotely unlock or lock the door or Use Alexa/Google Assistant, the smart lock needs to be connected with the G2 gateway(It's sold separately)



### How to Pair with Your TLock App

---

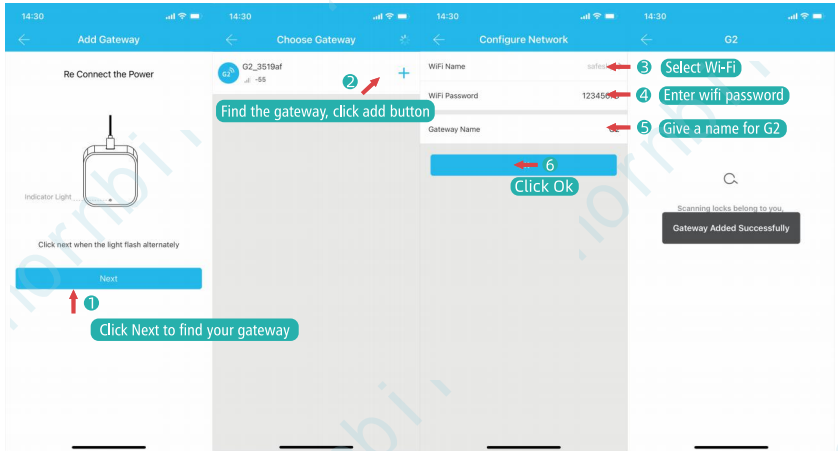
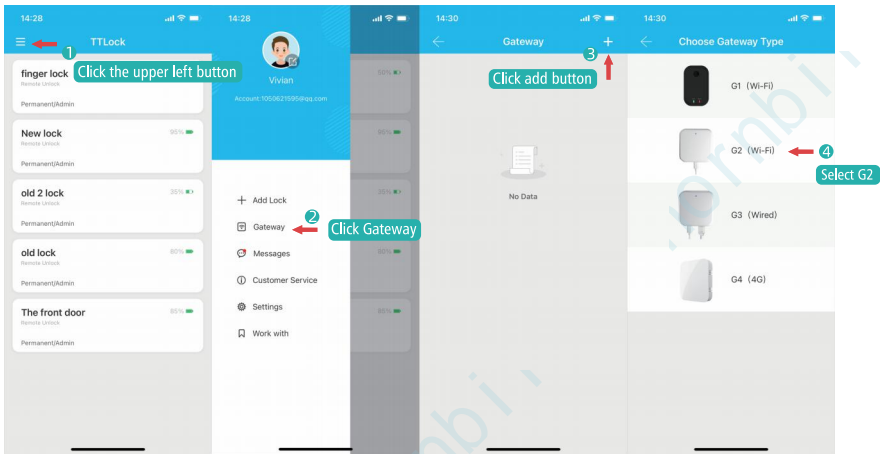
1. Please make sure your phone is connected with your Wi-Fi (works with 2.4Ghz Wi-Fi, it doesn't work with is 5Ghz), and make sure your smart lock have paired with your TLock account.(The gateway needs to near by your locks within 16 ft.)
2. Please plug your gateway into the power, it will red and blue flashing.
3. When you successfully add the gateway on your App, the gateway will find your locks, it may take about 3 minutes. Lastly, your locks connected to your gateway, go back you will find the gateway is online status, if you have two locks(The locks are close to the gateway with 16ft), please click Nearby locks, then your locks will connected to your gateway.



# How to Remotely Unlock or Lock the Door

1. Click Settings>remote unlock button>turn on
2. Remotely unlock: Touch the little button  >remote unlock the door.
3. Remotely lock: Hold the main button  >remotely lock the door.

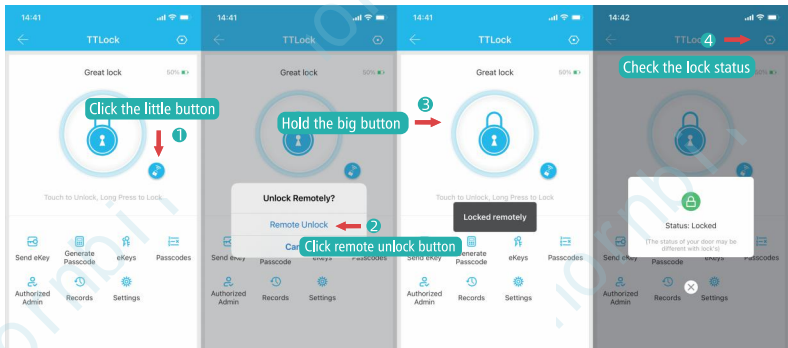
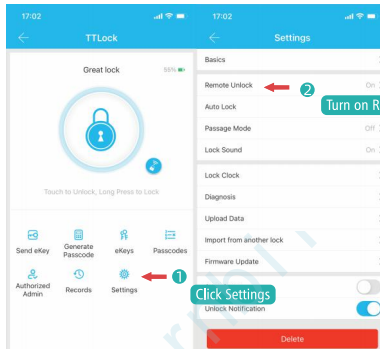

# How to Use Alexa to Control the Door

1. Please download Alexa App on your phone, and log in your account (Amazon account)
2. Click More-and click Skills&Games, the US customer to search **TTLock**, the Canada customer search **ScienerSmart**, and then click ENABLE TO USE.
3. Log in your TTLock Account and Password

**Note:** If your TTLock account is your phone number, please enter "+" +1" on front of your phone number. e.g: +18669859909)



# How to Use Google Home to Control the Door

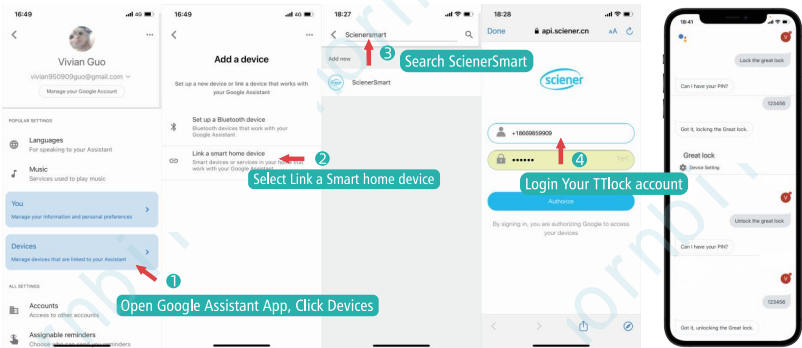
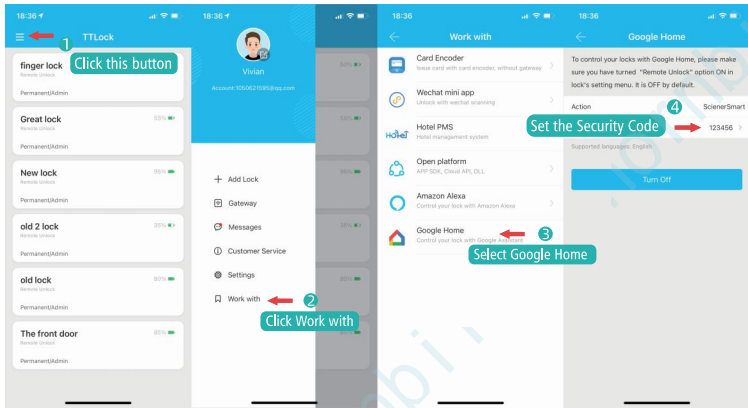

## 9. Troubleshooting

1. How can I unlock the door if the Smart Lock doesn't work?

- ① Press the reset button to restart the Smart Lock.
- ② Use the provided key to unlock.

2. How can I unlock the door if the Smart Lock's battery run slow?

- ① Insert a 9v battery touch the instant charging port to power the Smart Lock.

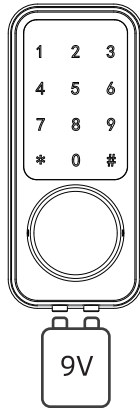

② Use the provided key to unlock.

3. The Smart Lock voice is too loud.

You can turn off the lock voice on the TLock App. Click settings>Lock Sound>Turn off

4. Why the Smart Lock's battery drains so quickly?

① Make sure you use the standard battery.

② Check whether the Smart Lock is installed properly.

③ Check whether the Smart Lock can be locked or unlocked smoothly using the thumb turn; If not, detach and install the Smart Lock again.

④ Check whether water spills in the Interior Assembly. Exposure to water will drain the battery quickly.

⑤ Contact Customer Service for technical support.

5. Why is everything going backwards?

① The lock is installed incorrectly, please take apart the back lock, you will find the toggle button, if the toggle button is on L, adjust it to R. If it is on R, adjust it to L. then your lock will be working.

② The lock only works with the physical key. It doesn't work when pull out the physical key.

The lock is installed incorrectly, we need to install the lock again, please take apart the exterior panel and the interior panel, adjust the flat ruler, make sure it is horizontal status, and the deadbolt is unlocked status, then your lock will be working.

**For troubleshooting, check the installation video and instructions. Or You can contact Customer Service staff for technical support via email.**

## 10. Customer Service

 Customer Support: [homide@milinaa.com](mailto:homide@milinaa.com)

 Phone Number: 1-866-985-9909 (Available after 6:00 PM at PT)  
FaceTime/iMessages: +8617688933815  
WhatsApp: +8617688933815  
Wechat: +8617688933815  
Skype: Vivianhornbill

 Smart Lock: 36-Month Limited Warranty  
Mechanical Part: 36-Month Limited Warranty

If you have any questions of the lock, please send email to us, we will help you.

## 11. How to Activate the Lock Warranty

When you received the lock, please send the information to the customer service, we will activate the warranty for the lock, then your lock will have a 2-year warranty and free lifetime customer service. When your lock is broken or defective, we will help you to get the replacement or help you to fix the issues asap. Thank you so much for your support.

Your Name:

Amazon Order Number:

## 12. Important Safety Instructions

1. DO NOT attempt to install or repair the product without authorization.
2. Do not use excessive force or sharp objects to press lock buttons, as this can damage the product.
3. Make sure the door is completely closed when going outside. The manufacturer does not assume responsibility for any harm caused by your improper closing the door.
4. Replace batteries when the low battery alarm is heard.
5. Change your access passcode regularly to ensure security.